



(11) **EP 3 113 163 A1**

(12) **EUROPEAN PATENT APPLICATION**

(43) Date of publication:
04.01.2017 Bulletin 2017/01

(51) Int Cl.:
G09G 3/3233 (2016.01)

(21) Application number: **16176788.4**

(22) Date of filing: **29.06.2016**

(84) Designated Contracting States:
AL AT BE BG CH CY CZ DE DK EE ES FI FR GB GR HR HU IE IS IT LI LT LU LV MC MK MT NL NO PL PT RO RS SE SI SK SM TR
 Designated Extension States:
BA ME
 Designated Validation States:
MA MD

(72) Inventors:
 • **KIM, Taegung**
10872 Gyeonggi-do (KR)
 • **KIM, Junghyeon**
10401 Gyeonggi-do (KR)

(74) Representative: **Ter Meer Steinmeister & Partner**
Patentanwälte mbB
Nymphenburger Straße 4
80335 München (DE)

(30) Priority: **30.06.2015 KR 20150093654**

(71) Applicant: **LG Display Co., Ltd.**
Yeongdeungpo-gu
Seoul
07336 (KR)

(54) **DEVICE AND METHOD FOR SENSING THRESHOLD VOLTAGE OF DRIVING TFT INCLUDED IN ORGANIC LIGHT EMITTING DISPLAY**

(57) Disclosed are a device and method for sensing the threshold voltage of a driving TFT included in an organic light emitting display so that a change in the threshold voltage of the driving TFT is sensed during real-time operation by reducing sensing time. First and second sensing voltages are obtained by fast sensing in the TFT linear region, and a change in the threshold voltage of the driving TFT is obtained based on the sensing ratio between the sensing voltages. Thus, a number of proc-

esses for deducing a change in threshold voltage, i.e., programming, source node resetting, sensing, and sampling, may be performed during the vertical blanking interval. That is, it is possible to sense a change in the threshold voltage of the driving TFT DT during real-time operation, without the need of arranging a time during power-on or power-off in order to sense a threshold voltage change, thereby improving compensation performance.

FIG. 7B

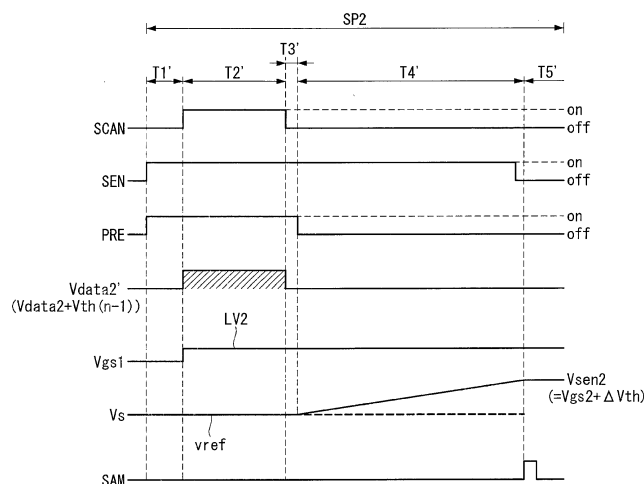

EP 3 113 163 A1

Description

BACKGROUND

Field of the Invention

[0001] The present invention relates to an organic light emitting display, and more particularly, to a device and method for sensing the threshold voltage of a driving TFT included in an organic light emitting display.

Discussion of the Related Art

[0002] An active-matrix organic light emitting display comprises organic light emitting diodes OLEDs that emit light themselves, and has the advantages of fast response time, high luminous efficiency, high luminance, and wide viewing angle.

[0003] An OLED, which is a self-luminous device, comprises an anode and a cathode, and organic compound layers HIL, HTL, EML, ETL, and EIL formed between the anode and cathode. The organic compound layers comprise a hole injection layer HIL, a hole transport layer HTL, an emission layer EML, an electron transport layer ETL, and an electron injection layer EIL. When an operating voltage is applied to the anode and the cathode, a hole passing through the hole transport layer HTL and an electron passing through the electron transport layer ETL move to the emission layer EML, forming an exciton. As a result, the emission layer EML generates visible light.

[0004] In an organic light emitting diode display, pixels each comprising an organic light emitting diode are arranged in a matrix, and the luminance of the pixels is adjusted based on the grayscale of video data. Each individual pixel comprises a driving TFT (thin-film transistor) that controls the drive current flowing through the OLED. The electrical characteristic of the driving TFT, such as threshold voltage, mobility, etc., may vary from pixel to pixel because of the process condition, driving environment, etc. Such variation in the electrical characteristics of the driving TFT causes luminance differences between the pixels. As a solution to this problem, the technology that senses the characteristic parameters (threshold voltage, mobility, etc.) of the driving TFT of each pixel and corrects image data based on the sensing results is known.

[0005] In the conventional art, as shown in FIG. 1, a driving TFT DT is operated according to a source follower method, and then the source node voltage V_s of the driving TFT DT is detected as a sensing voltage V_{sen} at the time t_a when the gate-source voltage V_{gs} of the driving TFT DT reaches saturation state by an electric current flowing through the driving TFT DT, in order to sense a change in the threshold voltage V_{th} of the driving TFT DT. However, a long period of time is needed in order for the gate-source voltage V_{gs} of the driving TFT DT to reach the threshold voltage V_{th} of the driving TFT DT.

Accordingly, in the conventional art, it is not possible to sense a change in the threshold voltage V_{th} of the driving TFT DT during real-time operation.

5 SUMMARY

[0006] Accordingly, the present invention is directed to a device and method for sensing the threshold voltage of a driving TFT included in an organic light emitting display so that a change in the threshold voltage of the driving TFT is sensed during real-time operation by reducing sensing time.

[0007] The object is solved by the features of the independent claims.

15 **[0008]** An exemplary embodiment of the present invention provides a device for sensing threshold voltage in an organic light emitting display with a plurality of pixels each having an OLED and a driving TFT for controlling the amount of light emitted by the OLED, the device comprising: a data drive circuit and a timing controller. The data drive circuit applies a first data voltage for sensing to the gate node of the driving TFT during a first programming period, obtains the source node voltage of the driving TFT as a first sensing voltage during a first sensing period in which the gate-source voltage of the driving TFT is constantly held at a first value higher than the threshold voltage of the driving TFT, applies a second data voltage for sensing to the gate node of the driving TFT during a second programming period, and obtains the source node voltage of the driving TFT as a second sensing voltage during a second sensing period in which the gate-source voltage of the driving TFT is constantly held at a second value higher than the threshold voltage of the driving TFT. The timing controller calculates an nth sensing ratio (n is a positive integer) based on the ratio between the first and second sensing voltages, calculates a change in sensing ratio by comparing the nth sensing ratio with a preset initial sensing ratio, and then obtains a change in the threshold voltage of the driving TFT based on the change in sensing ratio.

[0009] Preferably, the first programming period and the first sensing period are included in a first compensation period

[0010] Preferably, the second programming period and the second sensing period are included in a second compensation period.

[0011] Preferably, the first and second compensation periods are placed in a vertical blanking interval.

[0012] Preferably, the vertical blanking interval is the time between active intervals for image display

[0013] Preferably, data for image display is not written during the vertical blanking interval.

40 **[0014]** Preferably, the first and second compensation periods are arranged consecutively in the same vertical blanking interval.

55 **[0015]** Preferably, the first and second compensation periods are placed separately in different vertical blanking intervals.

[0016] Preferably, the data drive circuit may be adapted to supply a reference voltage to the source node of the driving TFT during a first initial period between the first programming period and the first sensing period.

[0017] Preferably, the data drive circuit may be adapted to supply the reference voltage to the source node of the driving TFT during a second initial period between the second programming period and the second sensing period.

[0018] Preferably, a gate drive circuit may be adapted to generate a scan control signal and/or a sensing control signal.

[0019] Preferably, each pixel may comprise a first switching TFT adapted to be turned on in response to the scan control signal to connect a data line connected to the data drive circuit to the gate node of the driving TFT,

[0020] Preferably, each pixel may comprise a second switching TFT adapted to be turned on in response to the sensing control signal to connect the source node of the driving TFT to a sensing line connected to a sensing unit in the data drive circuit, and a storage capacitor connected between the gate node and source node of the driving TFT.

[0021] Preferably, the sensing unit may comprise a reference voltage control switch adapted to be switched on in response to a reference voltage control signal to connect a reference voltage input terminal and the sensing line, and a sampling control switch adapted to be switched on in response to a sampling control signal (SAM) to connect the sensing line and a sample and hold circuit.

[0022] Preferably, the scan control signal is applied at ON level during the first and second programming periods,

[0023] Preferably, the sensing control signal is applied at ON level during the first and second programming periods, the first and second initial periods, and the first and second sensing periods

[0024] Preferably, the reference voltage control signal is applied at ON level during the first and second programming periods and the first and second initial periods.

[0025] Preferably, the sampling control signal is applied at ON level during a first sampling period after the first sensing period and a second sampling period after the second sensing period.

[0026] Another exemplary embodiment of the present invention provides a method for sensing threshold voltage in organic light emitting display with a plurality of pixels each having an OLED and a driving TFT for controlling the amount of light emitted by the OLED, the method comprising: applying a first data voltage for sensing to the gate node of the driving TFT during a first programming period and obtaining the source node voltage of the driving TFT as a first sensing voltage during a first sensing period in which the gate-source voltage of the driving TFT is constantly held at a first value higher than the threshold voltage of the driving TFT; applying a second data voltage for sensing to the gate node of the driving

TFT during a second programming period and obtaining the source node voltage of the driving TFT as a second sensing voltage during a second sensing period in which the gate-source voltage of the driving TFT is constantly held at a second value higher than the threshold voltage of the driving TFT; and calculating an nth sensing ratio (n is a positive integer) based on the ratio between the first and second sensing voltages, calculating a change in sensing ratio by comparing the nth sensing ratio with a preset initial sensing ratio, and then obtaining a change in the threshold voltage of the driving TFT based on the change in sensing ratio.

[0027] Preferably, the first programming period and the first sensing period are included in a first compensation period and the second programming period and the second sensing period are included in a second compensation period.

[0028] Preferably, the first and second compensation periods are placed in a vertical blanking interval, and the vertical blanking interval is the time between active intervals for image display, wherein data for image display is not written during the vertical blanking interval.

[0029] Preferably, the first and second compensation periods are placed consecutively in the same vertical blanking interval or the first and second compensation periods are placed separately in different vertical blanking intervals.

[0030] Preferably, the method may further comprise supplying a reference voltage to the source node of the driving TFT during a first initial period between the first programming period and the first sensing period and supplying the reference voltage to the source node of the driving TFT during a second initial period between the second programming period and the second sensing period.

BRIEF DESCRIPTION OF THE DRAWINGS

[0031] The accompanying drawings, which are included to provide a further understanding of the invention and are incorporated in and constitute a part of this specification, illustrate embodiments of the invention and together with the description serve to explain the principles of the invention. In the drawings:

FIG. 1 is a view showing a conventional technology for sensing the threshold voltage of a driving TFT according to a source follower method;

FIG. 2 is a view schematically showing an organic light emitting display according to an exemplary embodiment of the present invention;

FIG. 3 is a view showing an example of the configuration of a pixel array and a data driver IC;

FIG. 4 is a view showing the principle for deducing a change in the threshold voltage of the driving TFT based on a sensing ratio;

FIG. 5 is a circuit diagram showing detailed configurations of a pixel and a sensing unit according to

an exemplary embodiment of the present invention; FIG. 6 is a waveform diagram showing the compensation of a change in the mobility of the driving TFT according to an exemplary embodiment of the present invention;

FIGS. 7A and 7B are waveform diagrams showing a process of sensing a change in the threshold voltage of the driving TFT according to an exemplary embodiment of the present invention;

FIG. 8 is a view showing that the change in the threshold voltage of the driving TFT appears as the difference in slope between the curves in the TFT linear region;

FIG. 9 shows a method for sensing a change in the threshold voltage of the driving TFT according to an exemplary embodiment of the present invention; and FIG. 10 shows a vertical blanking interval in one frame during which a change in the threshold voltage of the driving TFT is sensed.

DETAILED DESCRIPTION

[0032] Hereinafter, exemplary embodiments of the present invention will be described in detail with reference to the accompanying drawings. Throughout the specification, like numbers refer to like elements. In describing the present invention, when it is deemed that a detailed description of known functions or configurations may unnecessarily obscure the subject matter of the present invention, the detailed description will be omitted

[0033] FIG. 2 is a view schematically showing an organic light emitting display according to an exemplary embodiment of the present invention. FIG. 3 is a view showing an example of the configuration of a pixel array and a data driver IC. FIG. 4 is a view showing the principle for deriving a change in the threshold voltage of the driving TFT based on a sensing ratio.

[0034] Referring to FIGS. 2 and 3, an organic light emitting display according to an exemplary embodiment of the present invention may comprise a display panel 10, a timing controller 11, a data drive circuit 12, a gate drive circuit 13, and a memory 16.

[0035] A plurality of data lines and sensing lines 14A and 14B and a plurality of gate lines 15 intersect each other on the display panel 10, and pixels P are arranged in a matrix at the intersections. The gate lines 15 comprise a plurality of first gate lines 15A sequentially supplied with a scan control signal (SCAN of FIG. 5) and a plurality of second gate lines 15B sequentially supplied with a sensing control signal (SEN of FIG. 5).

[0036] Each pixel P may be connected to any one of the data lines 14A, any one of the sensing lines 14B, any one of the first gate lines 15A, and any one of the second gate lines 15B. Each pixel P may be connected to a data line 14A in response to a scan control signal SCAN input through a first gate line 15A, and may be connected to a sensing line 14B in response to a sensing control signal SEN input through a second gate line 15B.

[0037] Each pixel P is supplied with a high-level operating voltage EVDD and a low-level operating voltage EVSS from a power generator (not shown). Each pixel P of this invention may comprise an OLED and a driving TFT that drives the OLED. The driving TFT may be implemented as p-type or n-type. Also, a semiconductor layer of the driving TFT may comprise amorphous silicon, polysilicon, or oxide.

[0038] Each pixel P displays an image, and may operate differently in an image display operation for internally compensating for a change in the mobility of the driving TFT and in a compensation operation for sensing and compensating for a change in the threshold voltage of the driving TFT. The compensation operation of this invention may be performed for a predetermined amount of time during power-on or power-off. Particularly, the compensation operation of this invention may reduce the time taken to sense a change in the threshold voltage of the driving TFT by a method to be described later. Thus, it is possible to sense a change in the threshold voltage of the driving TFT during vertical blanking intervals of a real-time operation, that is, image display operation.

[0039] The image display operation and the compensation operation may be implemented depending on the operation of the data drive circuit 12 and gate drive circuit 13 under the control of the timing controller 11.

[0040] The data drive circuit 12 comprises at least one data driver IC (integrated circuit) SDIC. The data driver IC (SDIC) may comprise a plurality of digital-to-analog converters (hereinafter, DAC) 121 connected to data lines 14A, a plurality of sensing units 122 connected to sensing lines 14B, a multiplexer (MUX) 123 that selectively connects the sensing units 122 to an analog-to-digital converter (hereinafter, ADC), and a shift register 124 that generates a selection control signal and sequentially turns on switches SS1 to SSk in the MUX 123.

[0041] In the compensation operation, the DACs generate a data voltage for sensing and supply it to the data lines 14A, under the control of the timing controller 11. In the image display operation, the DACs generate a data voltage for image display and supply it to the data lines 14A, under the control of the timing controller 11.

[0042] The sensing units SU#1 to SU#k may be connected to the sensing lines 14B on a one-to-one basis. The sensing units SU#1 to SU#k may supply a reference voltage to the sensing lines 14B or read a sensing voltage stored in the sensing lines 14B and supply it to the ADC, under the control of the timing controller 11.

[0043] The ADC converts a sensing voltage selectively input through the MUX 123 to a digital value and transmits it to the timing controller 11.

[0044] The gate drive circuit 13 may generate a scan control signal corresponding to the image display operation or compensation operation and then supply it to the first gate lines 15A line by line, under the control of the timing controller 11. The gate drive circuit 13 generates a sensing control signal corresponding to the image display operation or compensation operation and then sup-

plies it to the second gate lines 15Bline by line, under the control of the timing controller 11.

[0045] The timing controller 11 generates a data control signal DDC for controlling the operation timing of the data drive circuit 12 and a gate control signal GDC for controlling the operation timing of the gate drive circuit 131, based on timing signals such as a vertical synchronization signal Vsync, a horizontal synchronization signal Hsync, a dot clock signal DCLK, and a data enable signal DE. The timing controller 11 may differentiate between the image display operation and the compensation operation based on a predetermined reference signal (driving power enable signal, a vertical synchronization signal, a data enable signal, etc.), and generate a data control signal DDC and gate control signal GDC corresponding to each of the image display operation and compensation operation. Moreover, the timing controller 11 may further generate relevant switching control signals CON (including PRE and SAM of FIG. 5) in order to operate internal switches in each sensing unit SU#1 to SU#k for the image display operation and compensation operation.

[0046] As shown in FIG. 4, the timing controller 11 obtains a first sensing voltage Vsen1 and a second sensing voltage Vsen2 by sensing a change in the threshold voltage of the driving TFT twice for each pixel, and obtains a change in the threshold voltage of the driving TFT based on the sensing ratio VSR between the first and second sensing voltages Vsen1 and Vsen2. In FIG. 4, Vsen1_init indicates a first initial sensing voltage of when a first data voltage for sensing is applied, Vsen2_init indicates a second initial sensed voltage of when a second data voltage for sensing is applied. VSRinit is an initial sensing ratio, which is equal to the first initial sensing voltage Vsen1_init divided by the second initial sensing voltage Vsen2_init. The initial sensing ratio VSRinit may vary depending on the product model and specification, and is preset at the time of product release and stored in the internal memory of the display device.

[0047] In the present invention, when there is a change in the threshold voltage of the driving TFT due to driving stress, different sensing data voltages are applied to each pixel, and the source node voltage of the driving TFT is acquired as the first and second sensing voltages while the gate-source voltage of the driving TFT is higher than the threshold voltage of the driving TFT. The first and second sensing voltages comprise a change in the mobility of the driving TFT, as well as a change in the threshold voltage of the driving TFT. Thus, in the present invention, by calculating the sensing ratio between the first and second sensing voltages, the change in the mobility of the driving TFT commonly included in the first and second sensing voltages may be canceled out, and only the change in the threshold voltage of the driving TFT may be obtained. Conventionally, the source node voltage of the driving TFT is sensed at the timing when the gate-source voltage of the driving TFT is saturated at the threshold voltage of the driving TFT. This means

that the sensing requires a very long time, making it impossible to sense a change in the threshold voltage of the driving TFT during a vertical blanking interval in the image display operation. However, if the sensing is done while the gate-source voltage of the driving TFT is higher than the threshold voltage of the driving TFT, as in the present invention, the total time taken for the sensing is reduced to 1/10 of the conventional art even if the sensing is done twice. Accordingly, a change in the threshold voltage of the driving TFT can be adequately sensed during the vertical blanking interval in the image display operation.

[0048] In the compensation operation, the timing controller 11 calculates an nth sensing ratio (n is a positive integer) based on the ratio between the first and second sensing voltages, calculates a change in sensing ratio by comparing the nth sensing ratio with a preset initial sensing ratio, and then obtains a change in the threshold voltage based on the change in sensing ratio. The timing controller 11 may properly update an (n-1)th compensation value stored in the memory 16 based on the obtained threshold voltage change.

[0049] In the compensation operation, the timing controller 11 may transmit first and second compensation data corresponding to the first and second data voltage for sensings to the data drive circuit 12. Here, the first and second compensation data reflects the change in the threshold voltage of the driving TFT that was sensed in the previous sensing period. In the image display operation, the timing controller 11 may transmit image data RGB corresponding to the image display data voltage. Here, the image data RGB may be modulated in such a way as to compensate for the change in the threshold voltage of the driving TFT that was sensed in the previous sensing period.

[0050] FIG. 5 shows detailed configurations of a pixel and a sensing unit according to an exemplary embodiment of the present invention. FIG. 6 shows the compensation of a change in the mobility of the driving TFT according to an exemplary embodiment of the present invention.

[0051] FIGS. 7A and 7B show a process of sensing a change in the threshold voltage of the driving TFT according to an exemplary embodiment of the present invention. FIG. 8 shows that the change in the threshold voltage of the driving TFT appears as the difference in slope between the curves in the TFT linear region.

[0052] Referring to FIG. 5, a pixel P of this invention may comprise an OLED, a driving TFT (thin film transistor) DT, a storage capacitor Cst, a first switching TFT ST1, and a second switching TFT ST2.

[0053] The OLED comprises an anode connected to a source node Ns, a cathode connected to an input terminal of a low-level operating voltage EVSS, and an organic compound layer positioned between the anode and the cathode.

[0054] The driving TFT DT controls the amount of current input into the OLED based on a gate-source voltage

V_{gs}. The driving TFT DT comprises a gate electrode connected to a gate node Ng, a drain electrode connected to an input terminal of a high-level operating voltage EVDD, and a source electrode connected to the source node Ns. The storage capacitor C_{st} is connected between the gate node Ng and the source node Ns to maintain the gate-source voltage V_{gs} of the driving TFT DT. The first switching TFT ST1 applies a sensing data voltage V_{data} on a data line 14A to the gate node Ng in response to a scan control signal SCAN. The first switching TFT ST1 comprises a gate electrode connected to the first gate line 15A, a drain electrode connected to the data line 14A, and a source electrode connected to the gate node Ng. The second switching TFT ST2 switches on an electrical connection between the source node Ns and a sensing line 14B in response to a sensing control signal SEN. The second switching TFT ST2 comprises a gate electrode connected to a second gate line 15B, a drain electrode connected to the sensing line 14B, and a source node connected to the source node Ns.

[0055] Also, a sensing unit SU of this invention comprises a reference voltage control switch SW1, a sampling switch SW2, and a sample and hold circuit S/H.

[0056] The reference voltage control switch SW1 is switched on in response to a reference voltage control signal PRE to connect an input terminal of a reference voltage V_{ref} and the sensing line 14B. The sampling switch SW2 is switched on in response to a sampling control signal SAM to connect the sensing line 14B and the sample and hold circuit S/H. When the sampling switch SW2 is turned on, the sample and hold circuit S/H samples and holds the source node voltage V_s of the driving TFT DT stored in a line capacitor LC_a of the sensing line 14B as a sensing voltage V_{sen} and then passes it to an ADC. Here, a parasitic capacitor present in the sensing line 14B may be substituted for the line capacitor LC_a.

[0057] An image display operation for internally compensating for a change in the mobility of the driving TFT will be described below in conjunction with an exemplary configuration of such a pixel and FIG. 6. When a compensation value corresponding to a threshold voltage change is obtained in the compensation operation for sensing a change in threshold voltage, the image display operation is performed based on an image display data voltage reflecting the compensation voltage. A change in the mobility of the driving TFT is not compensated for in the compensation operation but compensated for in the image display operation. Accordingly, in the image display operation, an image is displayed, with the compensation of the changes in both the threshold voltage and mobility of the driving TFT.

[0058] The image display operation comprises a initial period T_i, a sensing period T_s, an emission period T_e. During the image display operation, the reference voltage control switch SW1 remains ON to apply the reference voltage V_{ref} to the sensing line 14B, and the sampling switch SW2 remains OFF.

[0059] In the initial period T_i, both the scan control signal SCAN and the sensing control signal SEN remain ON. The first switching TFT ST1 is turned on in response to the scan control signal SCAN of ON state to apply an image display data voltage to the gate electrode of the driving TFT DT, and the second switching TFT ST2 is turned on in response to the sensing control signal SEN of ON state and applies a reference voltage V_{ref} to the source electrode of the driving TFT DT.

[0060] In the sensing period T_s, the scan control signal SCAN remains ON, and the sensing control signal SEN is inverted to OFF. The first switching TFT ST1 remains ON and holds the voltage at the gate node Ng of the driving TFT DT at the image display data voltage. The second switching TFT ST2 is turned off, whereupon a current corresponding to a gate-source voltage difference V_{gs}, which is set in the initial period T_i, flows through the driving TFT DT. Accordingly, the voltage at the source node Ns of the driving TFT DT rises toward the image display data voltage applied to the gate electrode of the driving TFT DT according to a source-follower method, so that the gate-source voltage difference V_{gs} of the driving TFT DT is programmed to a desired gray level.

[0061] In the emission period T_e, both the scan control signal SCAN and the sensing control signal SEN remain OFF. The voltage at the gate node Ng of the driving TFT DT and the voltage at the source node Ns rise to a voltage level equal to or higher than the threshold voltage of the OLED while maintaining the voltage difference V_{gs} programmed in the sensing period T_s, and then maintain this voltage level. A drive current corresponding to the programmed gate-source voltage difference V_{gs} of the driving TFT DT flows through the OLED. As a result, the OLED emits light, thereby representing a desired gray level.

[0062] As such, a change in the mobility of the driving TFT DT is compensated for based on the principle that the source voltage V_s of the driving TFT DT is raised by capacitive coupling while the gate voltage V_g of the driving TFT DT is fixed at the image display data voltage during the sensing period T_s. The drive current, which determines the light intensity (luminance) of the pixel, is proportional to the mobility μ of the driving TFT DT and the gate-source voltage difference V_{gs} of the driving TFT DT programmed in the sensing period T_s. During the sensing period T_s, in the case of a pixel with high mobility μ , the source voltage V_s of the driving TFT DT rises at a first rate of rise toward the higher gate voltage V_g so that the gate-source voltage difference V_{gs} of the driving TFT DT is programmed to be relatively small. On the contrary, during the sensing period T_s, in the case of a pixel with low mobility μ , the source voltage V_s of the driving TFT DT rises at a second rate of rise (which is slower than the first rate of rise) toward the higher gate voltage V_g so that the gate-source voltage difference V_{gs} of the driving TFT DT is programmed to be relatively large. That is, the gate-source voltage is automatically programmed to be inversely proportional to the degree

of mobility. As a result, luminance variations caused by differences in mobility μ between pixels are compensated for.

[0063] A compensation operation for compensating a change in the threshold voltage of the driving TFT will be described below in conjunction with the above-described exemplary configuration of a pixel and FIGS. 7A and 7B and FIG. 8.

[0064] A compensation operation comprises a first process for obtaining a first sensing voltage V_{sen1} during a first compensation period SP1 shown in FIG. 7A, and a second process for obtaining a second sensing voltage V_{sen2} during a second compensation period SP2 shown in FIG. 7B. Here, the first compensation period SP1 and the second compensation period SP2 may be placed consecutively within one vertical blanking interval or separately in different vertical blanking intervals.

[0065] As shown in FIG. 7A, the first compensation period SP1 may comprise a first programming period T2, a first sensing period T4, and a first sampling period T5. The first compensation period SP1 may further comprise a first source node initial period T3 in order to increase sensing accuracy. In FIG. 7A, "T1" is a first sensing line initial period for resetting the sensing line 14B to a reference voltage V_{ref} in advance before the first programming period T2, and may be omitted.

[0066] In the first programming period T2, a scan control signal SCAN, sensing control signal SEN, and reference voltage signal PRE are all input as ON. In the first programming period T2, the first switching TFT ST1 is turned on to apply a first data voltage for sensing $V_{data1'}$ to the gate node N_g of the driving TFT DT, and the second switching TFT ST2 and the reference voltage control switch SW1 are turned on to apply the reference voltage V_{ref} to the source node N_s of the driving TFT DT. As a result, the gate-source voltage V_{gs} of the driving TFT DT is programmed to a first level LV1. Here, the first data voltage for sensing $V_{data1'}$ reflects a threshold voltage component $V_{th(n-1)}$ of the previous sensing period.

[0067] In the first source node initial period T3, the scan control signal SCAN is inverted to OFF, and the sensing control signal SEN and the reference voltage control signal PRE remain ON. In the first source node initial period T3, the first switching TFT ST1 is turned off to make the gate node N_g of the driving TFT DT float, and the second switching TFT ST2 and the reference voltage control switch SW1 are turned on to constantly apply the reference voltage V_{ref} to the source node N_s of the driving TFT DT. As a result, the source node N_s of the driving TFT DT is reset for the second time to the reference voltage V_{ref} while the gate-source voltage V_{gs} of the driving TFT DT is held at the first level LV1. The reason why the source node N_s of the driving TFT DT is reset for the second time to the reference voltage V_{ref} is because sensing accuracy can be increased by making the voltage at the start point of the first sensing period T4 equal for all pixels.

[0068] In the first sensing period T4, the scan control

signal SCAN is held at OFF level, the sensing control signal SEN is held at ON level, and the reference voltage control signal PRE is inverted to OFF level. In the first sensing period T4, the first switching TFT ST1 is turned off to keep the gate node N_g of the driving TFT DT floating, and the reference voltage control switch SW1 is turned off to disconnect the source node N_s of the driving TFT DT from an input of the reference voltage V_{ref} . In this state, a pixel current flows through the driving TFT DT by the gate-source voltage V_{gs} of the first level LV1, and the source node voltage V_s of the driving TFT DT rises due to this pixel current. The source node voltage V_s of the driving TFT DT is stored in the line capacitor LCa of the sensing line 14B by the turned-on second switching TFT ST2.

[0069] In the first sampling period T5, the sensing control signal SEN is inverted to OFF level, and the sampling control signal SAM is input as ON level. In the first sampling period T5, the second switching TFT ST2 is turned off to release the electrical connection between the source node N_s of the driving TFT DT and the sensing line 14B. Also, the sampling control switch SW2 is turned on to connect the sensing line 14B and the sample and hold circuit S/H, thereby sampling the source node voltage V_s of the driving TFT DT stored in the sensing line 14B as the first sensing voltage V_{sen1} . The first sensing voltage V_{sen1} is converted to a first digital value by an ADC and then stored in an internal latch in the data drive circuit 12.

[0070] As shown in FIG. 7B, the second compensation period SP2 may comprise a second programming period T2', a second sensing period T4', and a second sampling period T5'. The second compensation period SP2 may further comprise a second source node initial period T3' in order to increase sensing accuracy. In FIG. 7B, T1' is a second sensing line initial period for resetting the sensing line 14B to a reference voltage V_{ref} in advance before the second programming period T2', and may be omitted.

[0071] In the second programming period T2', a scan control signal SCAN, sensing control signal SEN, and reference voltage signal PRE are all input as ON. In the second programming period T2', the first switching TFT ST1 is turned on to apply a second data voltage for sensing $V_{data2'}$ to the gate node N_g of the driving TFT DT, and the second switching TFT ST2 and the reference voltage control switch SW1 are turned on to apply the reference voltage V_{ref} to the source node N_s of the driving TFT DT. As a result, the gate-source voltage V_{gs} of the driving TFT DT is programmed to a second level LV2. Here, the second data voltage for sensing $V_{data2'}$ reflects a threshold voltage component $V_{th(n-1)}$ of the previous sensing period.

[0072] In the second source node initial period T3', the scan control signal SCAN is inverted to OFF, and the sensing control signal SEN and the reference voltage control signal PRE remain ON. In the second source node initial period T3', the first switching TFT ST1 is turned off to make the gate node N_g of the driving TFT DT float,

and the second switching TFT ST2 and the reference voltage control switch SW1 are turned on to keep applying the reference voltage V_{ref} to the source node N_s of the driving TFT DT. As a result, the source node N_s of the driving TFT DT is reset for the second time to the reference voltage V_{ref} while the gate-source voltage V_{gs} of the driving TFT DT is held at the second level LV2. The reason why the source node N_s of the driving TFT DT is reset for the second time to the reference voltage V_{ref} is because sensing accuracy can be increased by making the voltage at the start point of the second sensing period $T4'$ equal for all pixels.

[0073] In the second sensing period $T4'$, the scan control signal SCAN is held at OFF level, the sensing control signal SEN is held at ON level, and the reference voltage control signal PRE is inverted to OFF level. In the second sensing period $T4'$, the first switching TFT ST1 is turned off to keep the gate node N_g of the driving TFT DT floating, and the reference voltage control switch SW1 is turned off to disconnect the source node N_s of the driving TFT DT from an input of the reference voltage V_{ref} . In this state, a pixel current flows through the driving TFT DT by the gate-source voltage V_{gs} of the second level LV2, and the source node voltage V_s of the driving TFT DT rises due to this pixel current. The source node voltage V_s of the driving TFT DT is stored in the line capacitor LCa of the sensing line 14B by the turned-on second switching TFT ST2.

[0074] In the second sampling period $T5'$, the sensing control signal SEN is inverted to OFF level, and the sampling control signal SAM is input as ON level. In the second sampling period $T5'$, the second switching TFT ST2 is turned off to release the electrical connection between the source node N_s of the driving TFT DT and the sensing line 14B. Also, the sampling control switch SW2 is turned on to connect the sensing line 14B and the sample and hold circuit S/H, thereby sampling the source node voltage V_s of the driving TFT DT stored in the sensing line 14B as the second sensing voltage V_{sen2} . The second sensing voltage V_{sen2} is converted to a second digital value by an ADC and then stored in an internal latch in the data drive circuit 12.

[0075] The first and second sensing voltages V_{sen1} and V_{sen2} stored as digital values in the internal latch are transmitted to the timing controller 11. The timing controller 11 calculates the sensing ratio VSR between the first and second sensing voltages V_{sen1} and V_{sen2} , and reads a change ΔV_{th} in the threshold voltage of the driving TFT DT from a look-up table by using a change in sensing ratio - which is obtained by subtracting the sensing ratio VSR from a preset initial sensing ratio VSR_{init} - as a read address.

[0076] In the present invention, a change in the threshold voltage of the driving TFT may be accurately sensed by canceling out a change in the mobility of the driving TFT commonly included in the first and second sensing voltages by using a sensing ratio VSR. According to the present invention, a threshold voltage change ΔV_{th} is

determined by a change in sensing ratio VSR. Even for pixels having driving TFTs with the same mobility, a change in the threshold voltage V_{th} of the driving TFT is represented as a difference in slope between the curves in the TFT linear region in which V_{gs} is lower than V_{th} . In the present invention, the voltage values in the TFT linear region are sensed in order to reduce the time taken for the sensing.

[0077] In the present invention, since a change in mobility is linearly and internally compensated for during the image display operation, accurate and fast sensing may be done in the TFT linear region during the compensation operation. In cases where fast sensing is done as discussed above without linearly compensating for a change in mobility, a sensing voltage comprises the change in mobility as well as a change in threshold voltage, and the change in mobility has a much greater effect on the sensing voltage, thereby making it possible to precisely detect a change in threshold voltage.

[0078] FIG. 9 shows a method for sensing a change in the threshold voltage of the driving TFT according to an exemplary embodiment of the present invention. FIG. 10 shows a vertical blanking interval in one frame during which a change in the threshold voltage of the driving TFT is sensed.

[0079] Referring to FIG. 9, in the present invention, first and second sensing voltages are obtained by fast sensing in the TFT linear region, and a change in the threshold voltage of the driving TFT is obtained based on the sensing ratio between the sensing voltages. Thus, a number of processes for deducing a change in threshold voltage, such as programming, source node resetting, sensing, and sampling, may be performed during the vertical blanking interval. That is, it is possible to sense a change in the threshold voltage of the driving TFT DT during real-time operation, without the need of arranging a time during power-on or power-off in order to sense a threshold voltage change, thereby improving compensation performance.

[0080] Here, the vertical blanking interval indicates the time between active intervals for image display during which data for image display is not written, as illustrated in FIG. 10. During the vertical blanking interval, a data enable signal DE continues to remain at low logic level L. When the data enable signal DE is at low logic level, data writing is paused.

[0081] Throughout the description, it should be understood by those skilled in the art that various changes and modifications are possible without departing from the technical principles of the present invention. Therefore, the technical scope of the present invention is not limited to the detailed descriptions in this specification but should be defined by the scope of the appended claims.

Claims

1. A device for sensing the threshold voltage (V_{th}) of a

driving TFT (DT) included in an organic light emitting display with a plurality of pixels (P) each having an OLED and a driving TFT (DT) for controlling the amount of light emitted by the OLED, the device comprising:

- a data drive circuit (12) adapted to apply a first data voltage (V_{data1}) for sensing to the gate node (N_g) of the driving TFT (DT) during a first programming period (T_2), obtain the source node voltage (V_{gs}) of the driving TFT (DT) as a first sensing voltage (V_{sen1}) during a first sensing period (T_4) in which the gate-source voltage (V_{gs}) of the driving TFT (DT) is constantly held at a first value higher than the threshold voltage (V_{th}) of the driving TFT (DT), apply a second data voltage (V_{data2}) for sensing to the gate node (N_g) of the driving TFT (DT) during a second programming period (T_2'), and obtain the source node voltage (V_s) of the driving TFT (DT) as a second sensing voltage (V_{sen2}) during a second sensing period (T_4') in which the gate-source voltage (V_{gs}) of the driving TFT (DT) is constantly held at a second value higher than the threshold voltage of the driving TFT (DT); and
- a timing controller (11) adapted to calculate an n th sensing ratio (VSR), n is a positive integer, based on the ratio between the first and second sensing voltages (V_{sen1}/V_{sen2}), calculate a change in sensing ratio (VSR) by comparing the n th sensing ratio with a preset initial sensing ratio, and then obtain a change in the threshold voltage of the driving TFT based on the change in sensing ratio.
2. The device of claim 1, wherein the first programming period (T_2) and the first sensing period (T_4) are included in a first compensation period (SP1), and the second programming period (T_2') and the second sensing period (T_4') are included in a second compensation period (SP2).
 3. The device of claim 2, wherein the first and second compensation periods (SP1, SP2) are placed in a vertical blanking interval, and the vertical blanking interval is the time between active intervals for image display, wherein data for image display is not written during the vertical blanking interval.
 4. The device of claims 2 or 3, wherein the first and second compensation periods (SP1, SP2) are arranged consecutively in the same vertical blanking interval or the first and second compensation periods (SP1, SP2) are placed separately in different vertical blanking intervals.
 5. The device as claimed in any one of the preceding

claims, wherein the data drive circuit (12) is adapted to supply a reference voltage (V_{ref}) to the source node (N_s) of the driving TFT (DT) during a first initial period (T_3) between the first programming period (T_2) and the first sensing period (T_4), and to supply the reference voltage (V_{ref}) to the source node (N_s) of the driving TFT (DT) during a second initial period (T_3') between the second programming period (T_2') and the second sensing period (T_4').

6. The device as claimed in any one of the preceding claims, further comprising a gate drive circuit (13) adapted to generate a scan control signal (SCAN) and a sensing control signal (SEN).
7. The device as claimed in any one of the preceding claims, wherein each pixel (P) further comprises a first switching TFT (ST1) adapted to be turned on in response to the scan control signal (SCAN) to connect a data line (14A) connected to the data drive circuit (12) to the gate node (N_g) of the driving TFT (DT), a second switching TFT (ST2) adapted to be turned on in response to the sensing control signal (SEN) to connect the source node (N_s) of the driving TFT (DT) to a sensing line (14B) connected to a sensing unit (SU) in the data drive circuit (12), and a storage capacitor (Cst) connected between the gate node (N_g) and source node (N_s) of the driving TFT.
8. The device as claimed in claim 7, wherein the sensing unit (SU) comprises a reference voltage control switch (SW1) adapted to be switched on in response to a reference voltage control signal (PRE) to connect a reference voltage input terminal and the sensing line (14B), and a sampling control switch (SW2) adapted to be switched on in response to a sampling control signal (SAM) to connect the sensing line (14B) and a sample and hold circuit (S/H).
9. The device as claimed in any one of the preceding claims, wherein the scan control signal (SCAN) is applied at ON level during the first and second programming periods (T_2, T_2'), the sensing control signal (SEN) is applied at ON level during the first and second programming periods (T_2, T_2'), the first and second initial periods (T_3, T_3'), and the first and second sensing periods (T_4, T_4'), the reference voltage control signal (PRE) is applied at ON level during the first and second programming periods (T_2, T_2') and the first and second initial periods (T_3, T_3'), and the sampling control signal (SAM) is applied at ON level during a first sampling period (T_5) after the first sensing period (T_4) and a second sampling period (T_5') after the second sensing period (T_4').
10. The device as claimed in any one of the preceding claims 7 to 9, wherein data drive circuit (12) comprises a multiplexer (123) for selectively connecting

the sensing units (SU) to an analog-to-digital converter, and a shift register (124) for generating a selection control signal and sequentially turning on switches SS1 to SSk in the multiplexer (123).

11. A method for sensing threshold voltage (V_{th}) in organic light emitting display with a plurality of pixels (P) each having an OLED and a driving TFT (DT) for controlling the amount of light emitted by the OLED, the method comprising:

applying a first data voltage ($V_{data1'}$) for sensing to the gate node (N_g) of the driving TFT (DT) during a first programming period (T2) and obtaining the source node voltage (V_{gs}) of the driving TFT (DT) as a first sensing voltage (V_{sen1}) during a first sensing period (T4) in which the gate-source voltage (V_{gs}) of the driving TFT (DT) is constantly held at a first value higher than the threshold voltage of the driving TFT (DT);

applying a second data voltage ($V_{data2'}$) for sensing to the gate node (N_g) of the driving TFT (DT) during a second programming period (T4') and

obtaining the source node voltage (V_{gs}) of the driving TFT (DT) as a second sensing voltage (V_{sen2}) during a second sensing period (T4') in which the gate-source voltage (V_{gs}) of the driving TFT (DT) is constantly held at a second value higher than the threshold voltage of the driving TFT (DT); and

calculating an nth sensing ratio (VSR), n is a positive integer, based on the ratio between the first and second sensing voltages (V_{sen1}/V_{sen2}),

calculating a change in sensing ratio by comparing the nth sensing ratio with a preset initial sensing ratio, and then

obtaining a change in the threshold voltage of the driving TFT (DT) based on the change in sensing ratio.

12. The method of claim 11, wherein the first programming period (T2) and the first sensing period (T4) are included in a first compensation period (SP1), and the second programming period (T2') and the second sensing period (T4') are included in a second compensation period (SP2).

13. The method of claim 12, wherein the first and second compensation periods (SP1, SP2) are placed in a vertical blanking interval, and the vertical blanking interval is the time between active intervals for image display, wherein data for image display is not written during the vertical blanking interval.

14. The method of claim 12 or 13, wherein the first and

second compensation periods (SP1, SP2) are placed consecutively in the same vertical blanking interval or the first and second compensation periods (SP1, SP2) are placed separately in different vertical blanking intervals.

15. The method as claimed in any one of the preceding claims 11 - 14, further comprising supplying a reference voltage (V_{ref}) to the source node (N_s) of the driving TFT (DT) during a first initial period (T3) between the first programming period (T2) and the first sensing period (T4) and supplying the reference voltage (V_{ref}) to the source node (N_s) of the driving TFT (DT) during a second initial period (T3') between the second programming period (T2') and the second sensing period (T4').

FIG. 1
(RELATED ART)

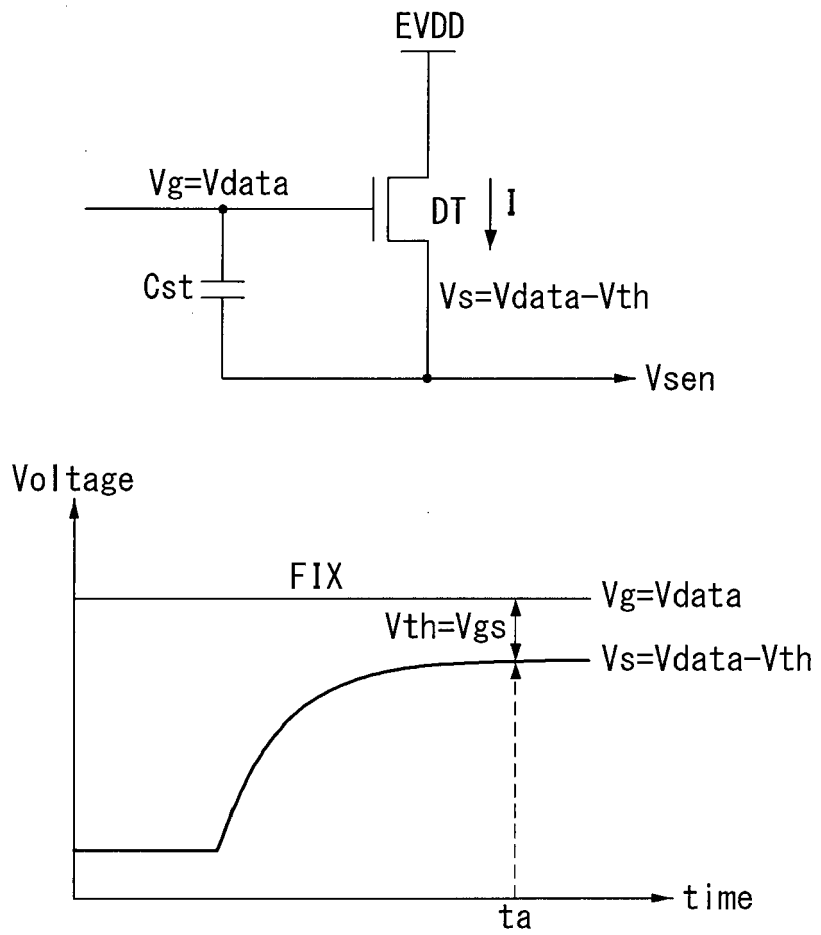

FIG. 2

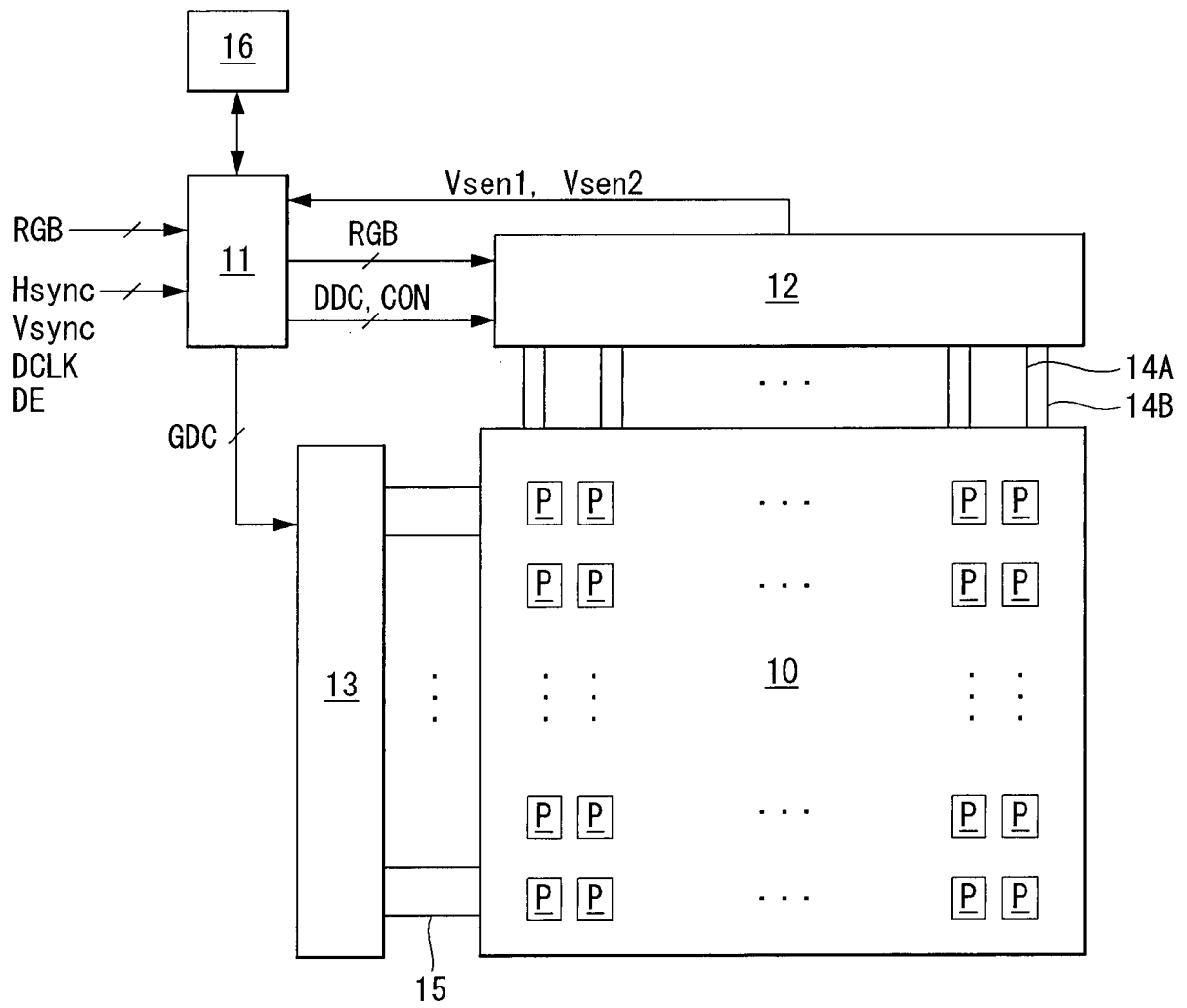

FIG. 3

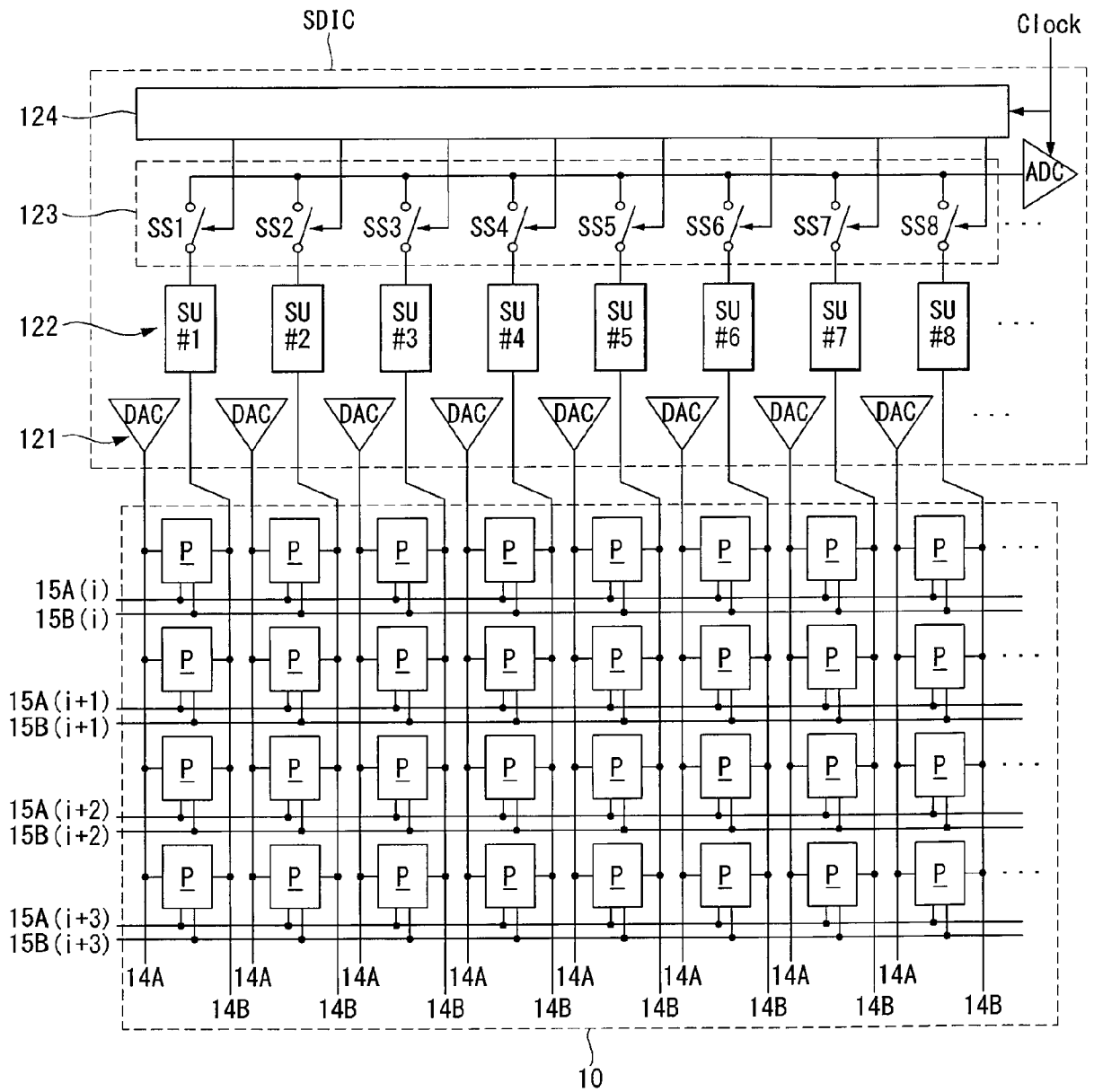

FIG. 4

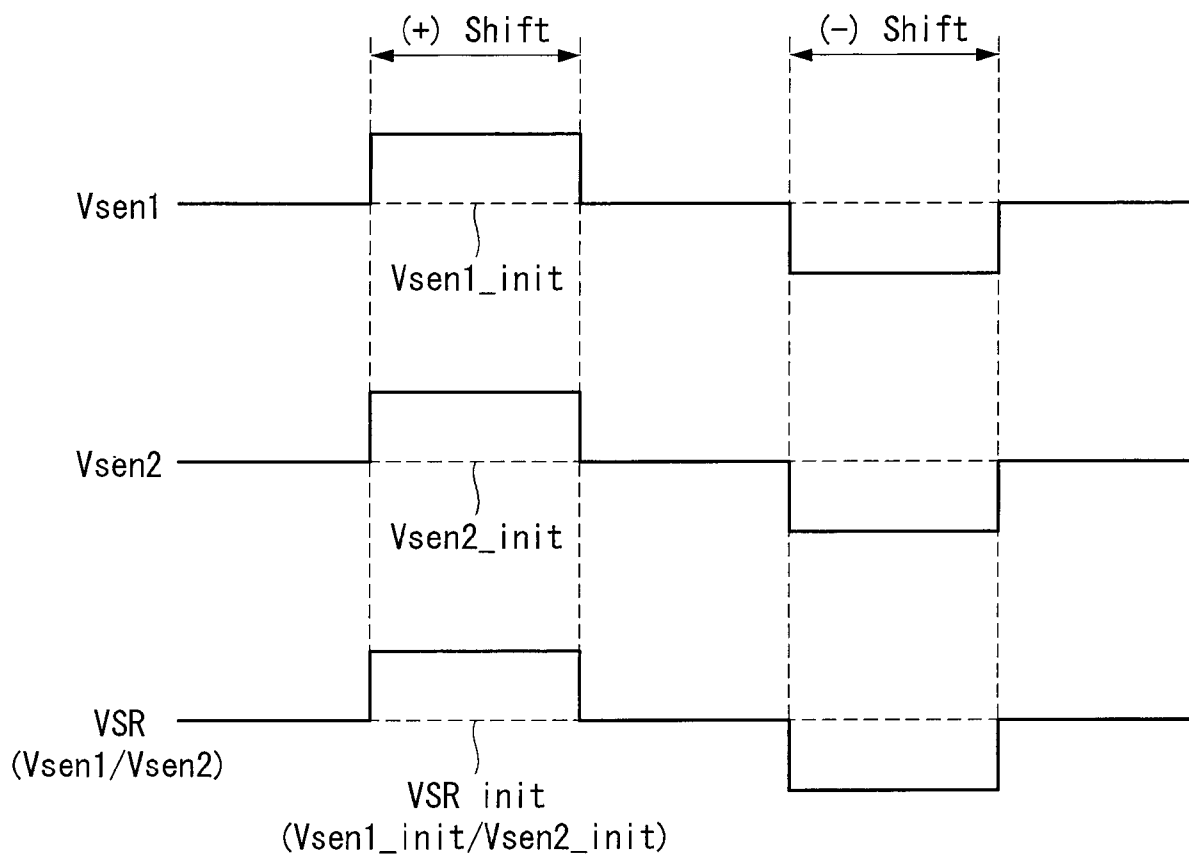

FIG. 5

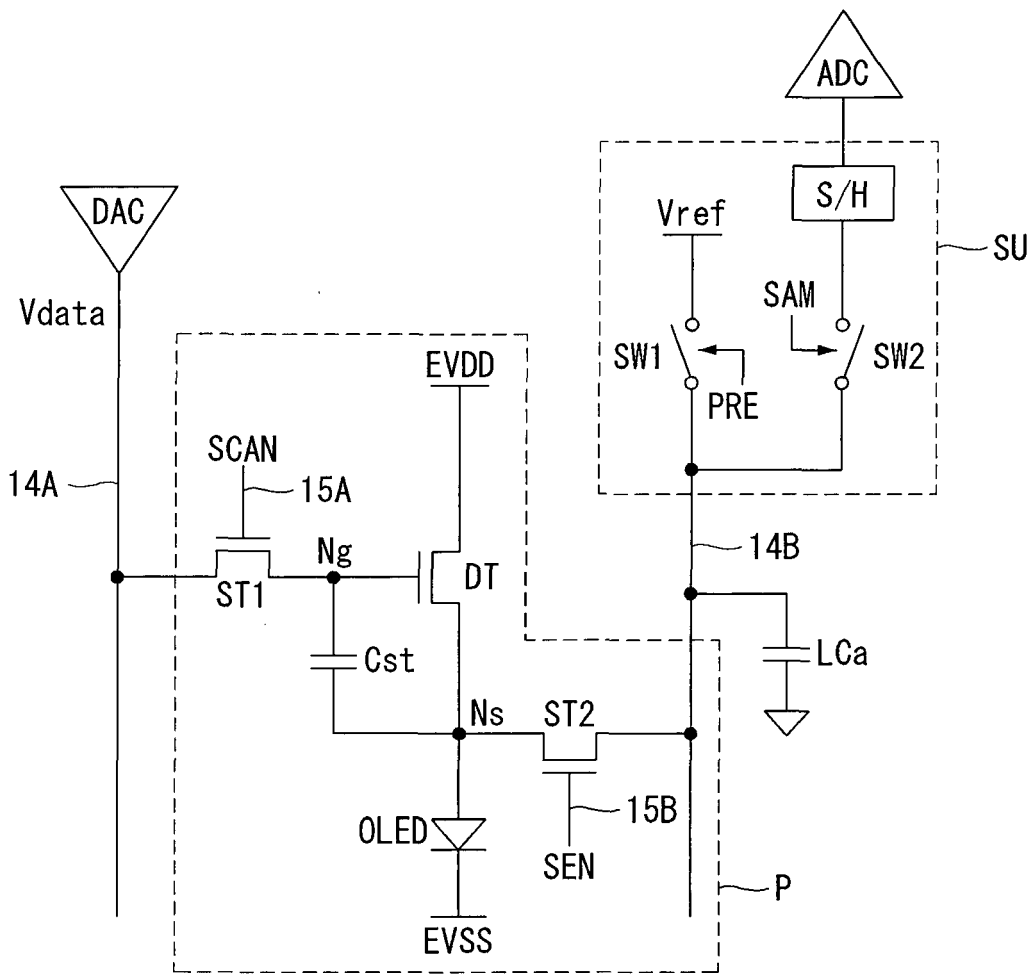
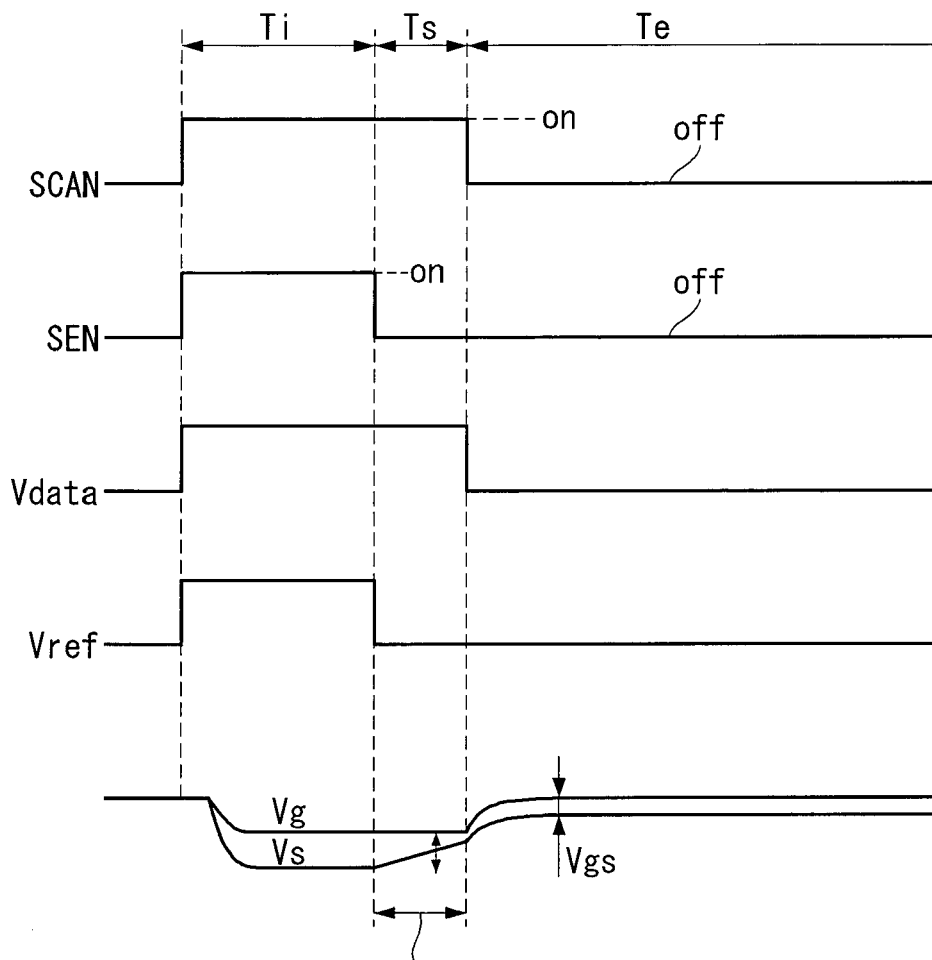

FIG. 6



Internal compensation for $\mu \rightarrow$
current difference compensation

FIG. 7A

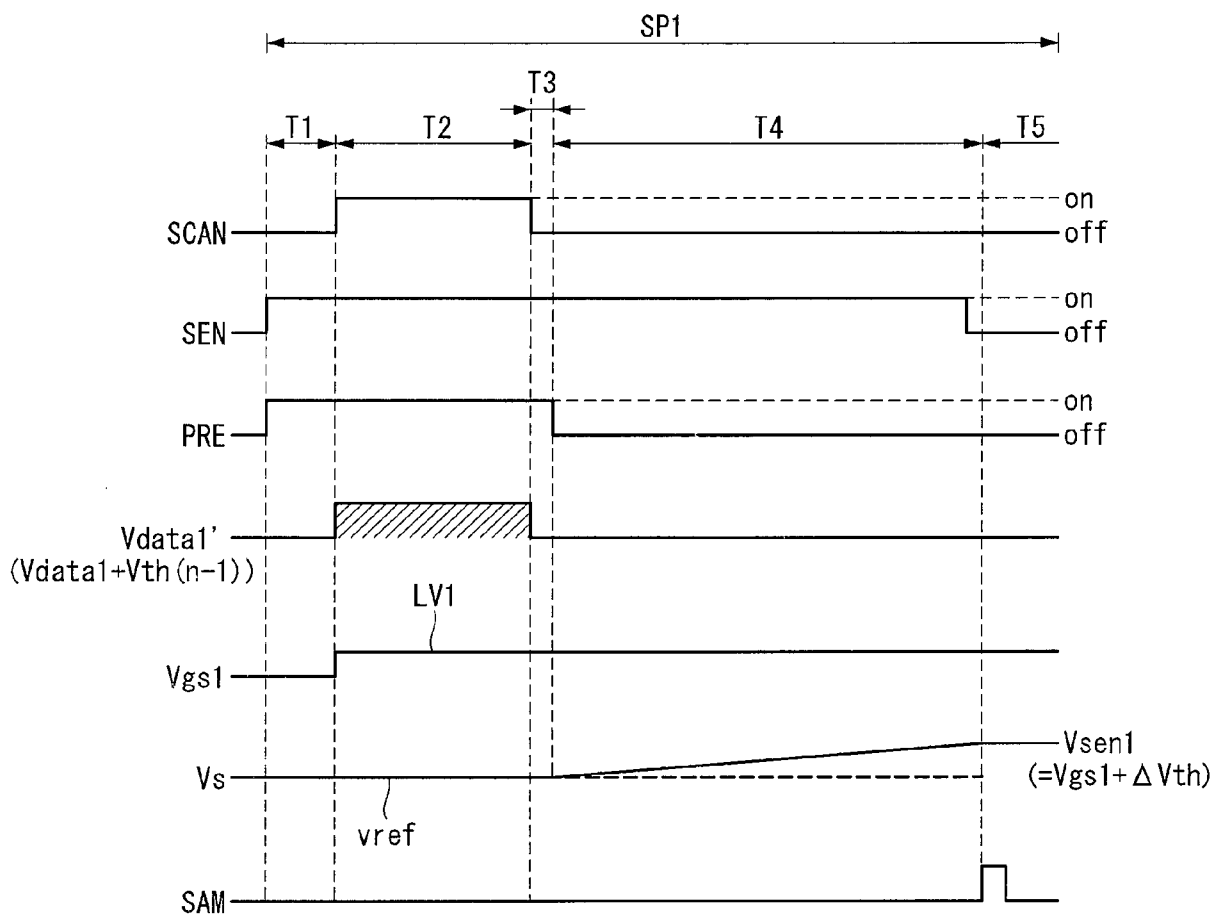

FIG. 7B

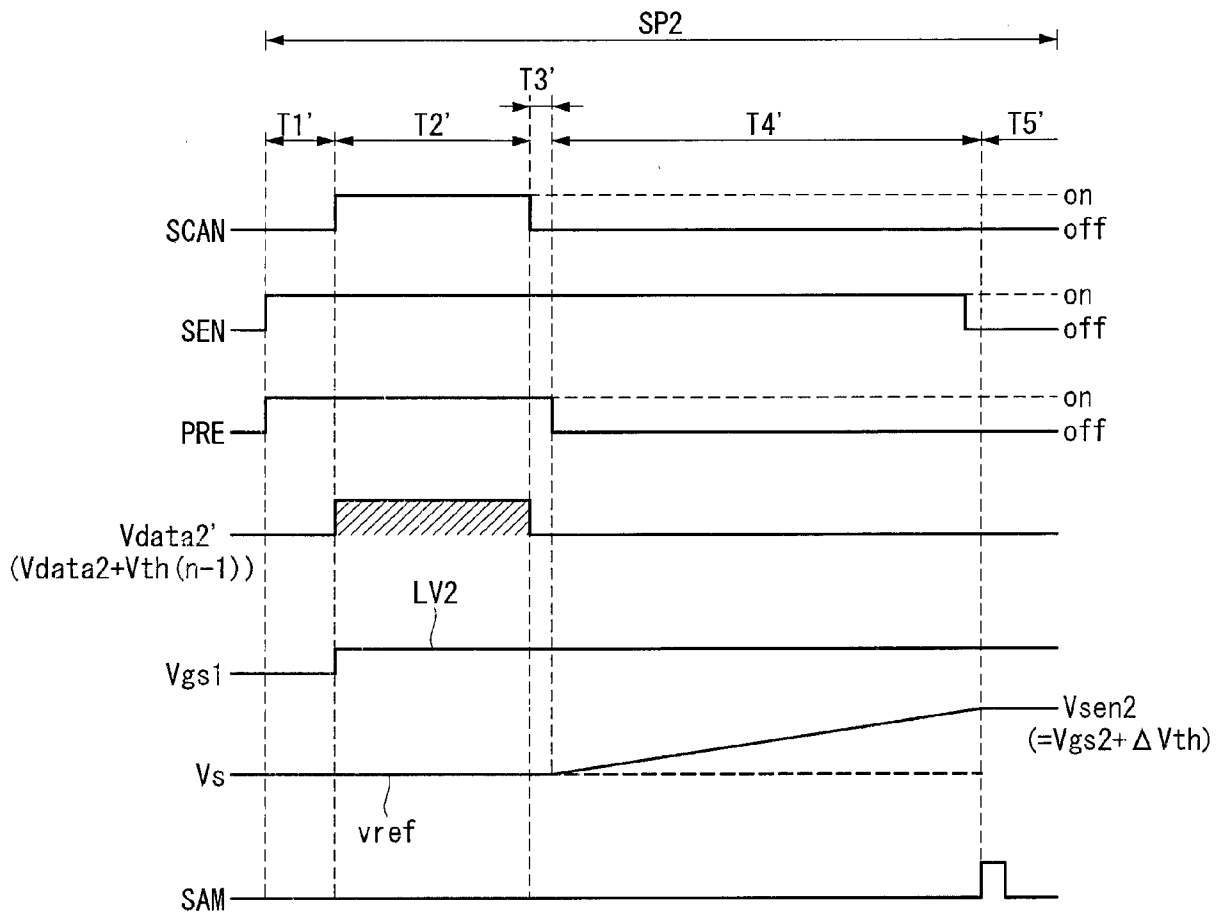

FIG. 8

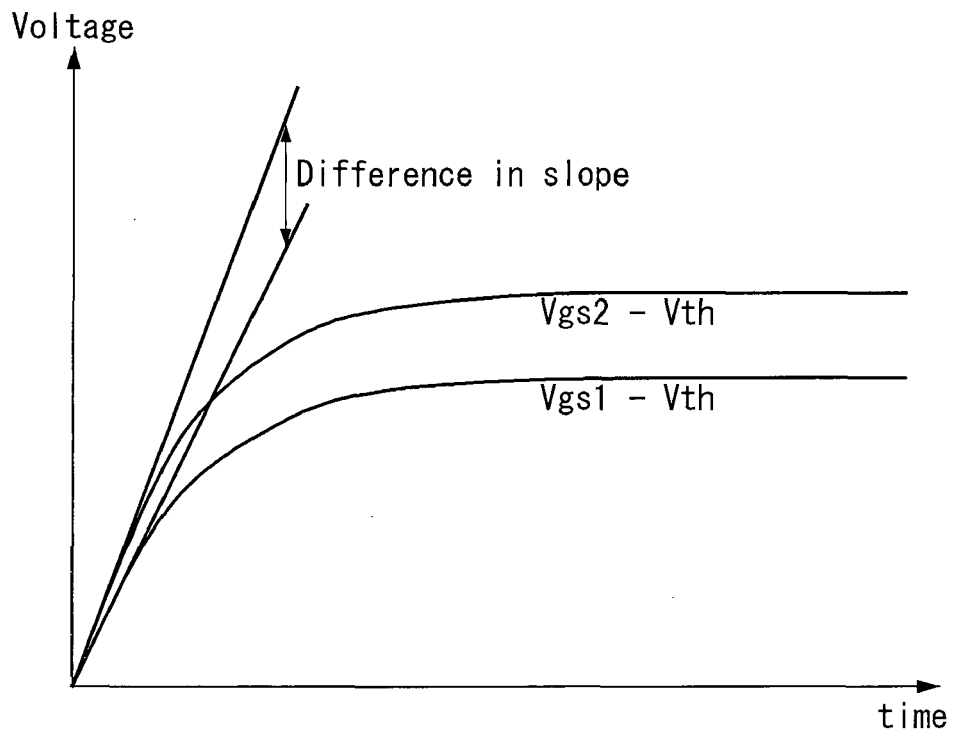

FIG. 9

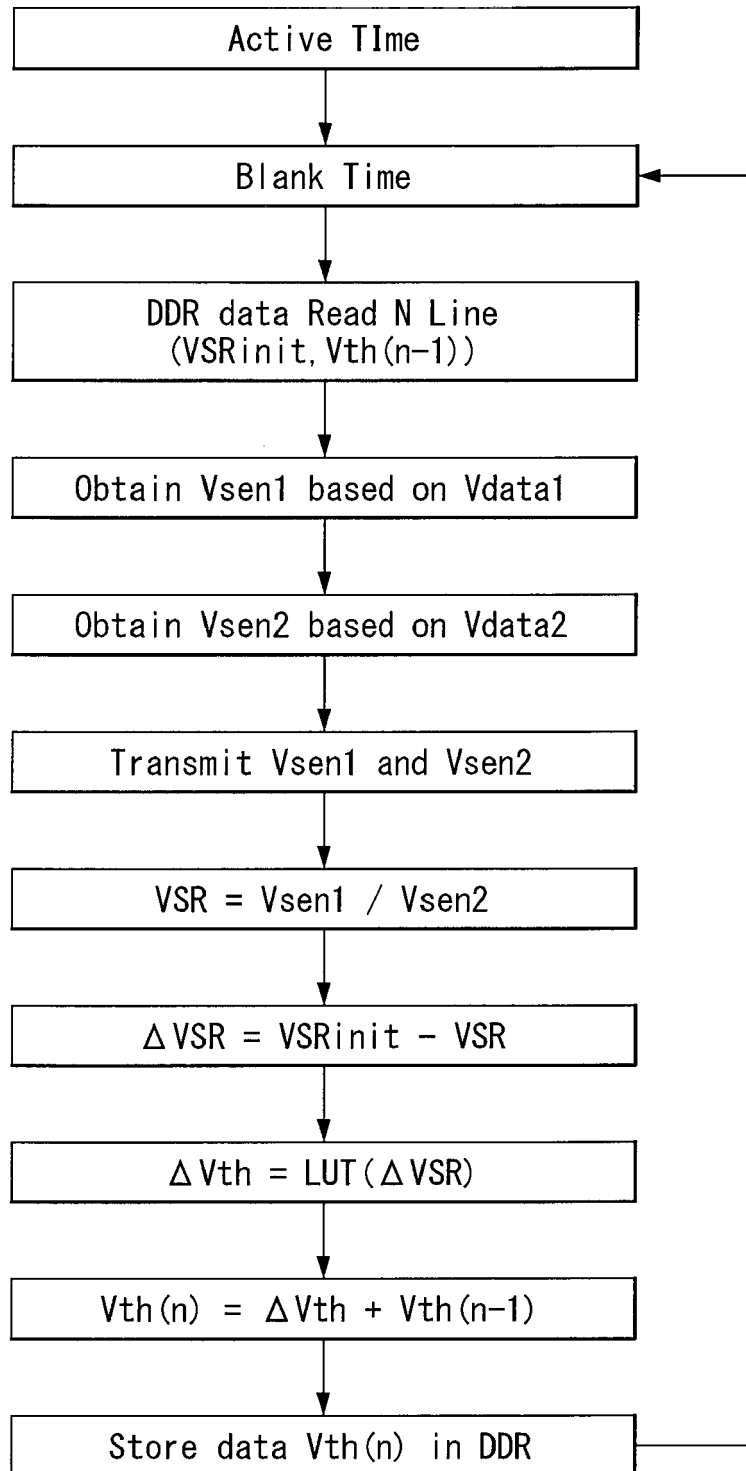
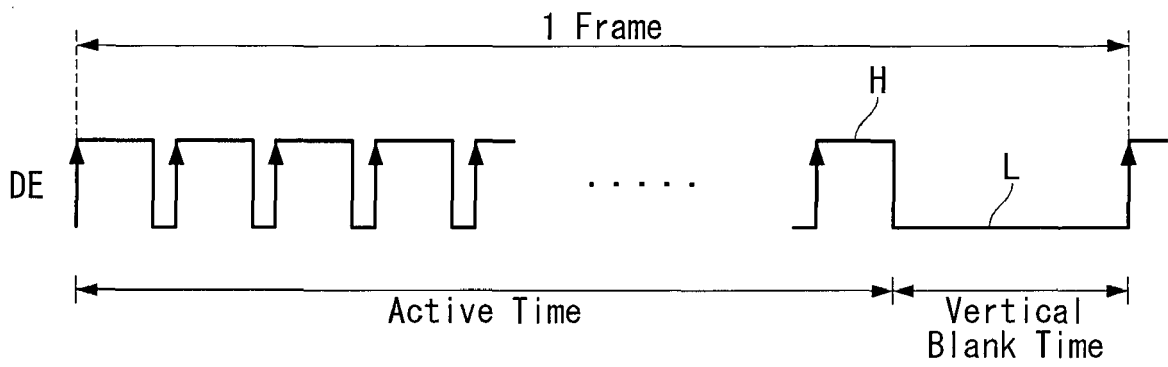

FIG. 10





EUROPEAN SEARCH REPORT

Application Number
EP 16 17 6788

5

10

15

20

25

30

35

40

45

50

55

DOCUMENTS CONSIDERED TO BE RELEVANT			
Category	Citation of document with indication, where appropriate, of relevant passages	Relevant to claim	CLASSIFICATION OF THE APPLICATION (IPC)
X	US 2013/162617 A1 (YOON JOONG-SUN [KR] ET AL) 27 June 2013 (2013-06-27) * paragraphs [0071] - [0081]; figures 6A,6B,6C,7,8 *	1-15	INV. G09G3/3233
A	US 2011/032264 A1 (IETOMI KUNIHICO [JP]) 10 February 2011 (2011-02-10) * paragraph [0056]; figure 5 *	1,11	
A	US 2011/205250 A1 (YOO MYOUNG-HWAN [KR] ET AL) 25 August 2011 (2011-08-25) * paragraphs [0153] - [0156]; figure 4 *	1-15	
A	US 2010/039422 A1 (SETO YASUHIRO [JP]) 18 February 2010 (2010-02-18) * paragraphs [0150] - [0202]; figures 2,3,4 *	1-15	
A	US 2008/074413 A1 (OGURA JUN [JP]) 27 March 2008 (2008-03-27) * paragraphs [0220] - [0224]; figures 20,21,22 *	1-15	
The present search report has been drawn up for all claims			TECHNICAL FIELDS SEARCHED (IPC)
			G09G
Place of search		Date of completion of the search	Examiner
The Hague		1 September 2016	Ladiray, Olivier
CATEGORY OF CITED DOCUMENTS			
X : particularly relevant if taken alone Y : particularly relevant if combined with another document of the same category A : technological background O : non-written disclosure P : intermediate document T : theory or principle underlying the invention E : earlier patent document, but published on, or after the filing date D : document cited in the application L : document cited for other reasons & : member of the same patent family, corresponding document			

EPO FORM 1503 03/02 (P04C01)

ANNEX TO THE EUROPEAN SEARCH REPORT
ON EUROPEAN PATENT APPLICATION NO.

EP 16 17 6788

5

This annex lists the patent family members relating to the patent documents cited in the above-mentioned European search report. The members are as contained in the European Patent Office EDP file on
The European Patent Office is in no way liable for these particulars which are merely given for the purpose of information.

01-09-2016

10

15

20

25

30

35

40

45

50

55

Patent document cited in search report	Publication date	Patent family member(s)	Publication date
US 2013162617 A1	27-06-2013	CN 103177685 A	26-06-2013
		DE 102012112569 A1	27-06-2013
		GB 2498634 A	24-07-2013
		KR 20130074147 A	04-07-2013
		US 2013162617 A1	27-06-2013

US 2011032264 A1	10-02-2011	CN 101996551 A	30-03-2011
		JP 2011034004 A	17-02-2011
		US 2011032264 A1	10-02-2011
		US 2011032281 A1	10-02-2011

US 2011205250 A1	25-08-2011	CN 102163402 A	24-08-2011
		JP 5761776 B2	12-08-2015
		JP 2011175226 A	08-09-2011
		KR 20110096877 A	31-08-2011
		TW 201133449 A	01-10-2011
		US 2011205250 A1	25-08-2011

US 2010039422 A1	18-02-2010	JP 5107824 B2	26-12-2012
		JP 2010044299 A	25-02-2010
		US 2010039422 A1	18-02-2010

US 2008074413 A1	27-03-2008	CN 101271663 A	24-09-2008
		JP 4222426 B2	12-02-2009
		JP 2008107774 A	08-05-2008
		KR 20080028334 A	31-03-2008
		TW 200826045 A	16-06-2008
		US 2008074413 A1	27-03-2008

专利名称(译)	用于感测包括在有机发光显示器中的驱动TFT的阈值电压的装置和方法		
公开(公告)号	EP3113163A1	公开(公告)日	2017-01-04
申请号	EP2016176788	申请日	2016-06-29
[标]申请(专利权)人(译)	乐金显示有限公司		
申请(专利权)人(译)	LG DISPLAY CO. , LTD.		
当前申请(专利权)人(译)	LG DISPLAY CO. , LTD.		
[标]发明人	KIM TAEGUNG KIM JUNGHYEON		
发明人	KIM, TAEGUNG KIM, JUNGHYEON		
IPC分类号	G09G3/3233		
CPC分类号	G09G3/3225 G09G3/3233 G09G2300/0842 G09G2310/0289 G09G2320/0233 G09G2320/0252 G09G2320/0295 G09G2320/043		
审查员(译)	LADIRAY , OLIVIER		
优先权	1020150093654 2015-06-30 KR		
其他公开文献	EP3113163B1 EP3113163B8		
外部链接	Espacenet		

摘要(译)

公开了一种用于感测包括在有机发光显示器中的驱动TFT的阈值电压的装置和方法，使得通过减少感测时间在实时操作期间感测驱动TFT的阈值电压的变化。通过TFT线性区域中的快速感测获得第一和第二感测电压，并且基于感测电压之间的感测比率获得驱动TFT的阈值电压的变化。因此，可以在垂直消隐间隔期间执行用于推断阈值电压的变化（即，编程，源节点重置，感测和采样）的多个过程。也就是说，可以在实时操作期间感测驱动TFT DT的阈值电压的变化，而不需要在电源接通或断电期间布置时间以便感测阈值电压变化，从而提高薪酬绩效。

FIG. 7B

