

(19)



(11)

EP 2 381 479 B1

(12)

EUROPEAN PATENT SPECIFICATION

(45) Date of publication and mention of the grant of the patent:
23.01.2013 Bulletin 2013/04

(51) Int Cl.:
H01L 27/32^(2006.01)

(21) Application number: **11163504.1**

(22) Date of filing: **21.04.2011**

(54) Organic light-emitting display apparatus

Organische lichtemittierende Vorrichtung

Appareil d'affichage électroluminescent organique

(84) Designated Contracting States:
AL AT BE BG CH CY CZ DE DK EE ES FI FR GB GR HR HU IE IS IT LI LT LU LV MC MK MT NL NO PL PT RO RS SE SI SK SM TR

(30) Priority: **26.04.2010 KR 20100038531**
31.03.2011 KR 20110029857

(43) Date of publication of application:
26.10.2011 Bulletin 2011/43

(73) Proprietor: **Samsung Display Co., Ltd.**
Yongin-City, Gyeonggi-Do, 446-711 (KR)

(72) Inventors:
• **Sun, Jin-Won**
Gyeonggi-Do
Yongin-City 446-711 (KR)
• **Suh, Min-Chul**
Gyeonggi-Do
Yongin-City 446-711 (KR)

- **Lee, Jae-Ho**
Gyeonggi-Do
Yongin-City 446-711 (KR)
- **Kang, Tae-Min**
Gyeonggi-Do
Yongin-City 446-711 (KR)
- **Noh, Sok-Won**
Gyeonggi-Do
Yongin-City 446-711 (KR)

(74) Representative: **Gulde Hengelhaupt Ziebig & Schneider**
Patentanwälte - Rechtsanwälte
Wallstraße 58/59
10179 Berlin (DE)

(56) References cited:
JP-A- 2009 199 868 US-A1- 2006 082 292
US-A1- 2007 257 253

EP 2 381 479 B1

Note: Within nine months of the publication of the mention of the grant of the European patent in the European Patent Bulletin, any person may give notice to the European Patent Office of opposition to that patent, in accordance with the Implementing Regulations. Notice of opposition shall not be deemed to have been filed until the opposition fee has been paid. (Art. 99(1) European Patent Convention).

Description

BACKGROUND

1. Field

[0001] Aspects of the present invention relate to an organic light-emitting display apparatus, and more particularly, to an active matrix organic light-emitting display apparatus.

2. Description of the Related Art

[0002] Organic light-emitting display apparatuses are self-emitting display apparatuses that emit light by applying a voltage to an organic layer including a pixel electrode, a counter electrode, and an emission layer disposed between the pixel electrode and the counter electrode to cause electrons and holes to recombine with each other in the emission layer. Organic light-emitting display apparatuses have been spotlighted as the next generation display apparatuses because of their lighter and thinner design, wider viewing angle, faster response time, and lower power consumption compared to cathode ray tubes (CRTs) or liquid crystal displays (LCDs).

[0003] Organic light-emitting display apparatuses are classified into passive matrix (PM) organic light-emitting display apparatuses and active matrix (AM) organic light-emitting display apparatuses according to driving methods. Advantages of AM organic light-emitting display apparatuses include high resolution, high image quality, low power consumption, and long lifetime. In an AM organic light-emitting display apparatus, a thin film transistor (TFT) and a pixel electrode are electrically connected to each other through a via-hole. A pixel defining layer (PDL) defines a light-emitting area surrounding each pixel electrode. An AM organic light-emitting display apparatus is known from US 2006/0082292 A1.

SUMMARY

[0004] Aspects of the present invention provide an organic light-emitting display apparatus that improves display quality by preventing a pixel defining layer that surrounds an edge portion of a pixel electrode from falling down due to a via-hole formed near the pixel electrode.

[0005] According to an aspect of the present invention, there is provided an organic light-emitting display apparatus including: a plurality of thin film transistors (TFTs); a planarization layer covering the plurality of TFTs; a plurality of pixel electrodes formed on the planarization layer, each of the pixel electrodes being connected to a corresponding one of the plurality of TFTs using a via-hole passing through the planarization layer and having a light-emitting portion and a non-emitting portion, and each of the via-holes being located at a point farthest from each of the light-emitting portions surrounding the via-hole; a pixel defining layer formed on the planariza-

tion layer to respectively cover each of the via-holes and the non-emitting portions; organic layers, each organic layer including an emission layer and being disposed in a corresponding one of the light-emitting portions; and a counter electrode disposed on each of the organic layers, wherein the thickness of the pixel defining layer is larger than the thickness of the organic layers.

[0006] According to an aspect of the present invention, the plurality of pixel electrodes may be patterned in a first direction and a second direction perpendicular to the first direction, and each of the plurality of via-holes may be formed at a position farthest from outer limits of the light-emitting portions of the plurality of pixel electrodes that are adjacent in the first direction and the second direction and disposed around the via-hole.

[0007] According to an aspect of the present invention, each of the plurality of via-holes may be formed at an intersection of first and second straight lines, the first straight line connecting central points between adjacent pairs of the light-emitting portions that are adjacent in the first direction and disposed around the via-hole and the second straight line connecting central points between adjacent pairs of the light-emitting portions that are adjacent in the second direction and disposed around the via-hole.

[0008] According to an aspect of the present invention, the first straight line and the second straight line may perpendicularly intersect each other.

[0009] According to an aspect of the present invention, each via-hole may be disposed substantially at a common point between diagonally adjacent pairs of the light-emitting portions.

[0010] According to an aspect of the present invention, the light-emitting portions may be arranged in a first grid pattern, and the via-holes may be arranged in a second grid pattern offset from the first grid pattern.

[0011] According to an aspect of the present invention, the light-emitting portions may be arranged in a first grid pattern, and the via-holes may be arranged in second grid pattern offset from the first grid pattern.

[0012] According to an aspect of the present invention, the light-emitting portions may not be disposed on a straight line formed by connecting adjacent via-holes.

[0013] According to an aspect of the present invention, relative to the substrate, a height of a portion of the pixel defining layer formed over each of the plurality of via-holes may be lower than a height of a portion of each of the pixel electrodes formed on the light-emitting portion.

[0014] According to an aspect of the present invention, a thickness of the pixel defining layer may be at or between 50 nm (500 Å) and 500 nm (5000 Å).

[0015] According to an aspect of the present invention, the pixel defining layer may be substantially planar except at portions covering the via-holes.

[0016] According to an aspect of the present invention, via-hole connecting portions of the plurality of pixel electrodes may have the same pattern.

[0017] Additional aspects and/or advantages of the in-

vention will be set forth in part in the description which follows and, in part, will be obvious from the description, or may be learned by practice of the invention.

BRIEF DESCRIPTION OF THE DRAWINGS

[0018] These and/or other aspects and advantages of the invention will become apparent and more readily appreciated from the following description of the embodiments, taken in conjunction with the accompanying drawings of which:

FIG. 1 is a cross-sectional view of an organic light-emitting display apparatus according to an embodiment of the present invention;

FIG. 2 is a cross-sectional view of an organic light-emitting display apparatus according to another embodiment of the present invention;

FIG. 3 is a plan view illustrating a display unit of the organic light-emitting display apparatus of FIG. 1 or 2;

FIG. 4 is a cross-sectional view taken along line A-A of FIG. 3;

FIG. 5 is a cross-sectional view illustrating an organic layer and a counter electrode added to a pixel electrode of FIG. 4; and

FIG. 6 is a plan view illustrating a positional relationship between a via-hole and a light-emitting portion of the pixel electrode of FIG. 3.

DETAILED DESCRIPTION

[0019] Reference will now be made in detail to the present embodiments of the present invention, examples of which are illustrated in the accompanying drawings, wherein like reference numerals refer to the like elements throughout. The embodiments are described below in order to explain the present invention by referring to the figures.

[0020] FIG. 1 is a cross-sectional view of an organic light-emitting display apparatus according to an embodiment of the present invention. Referring to FIG. 1, a display unit 20 is disposed on a substrate 10. An encapsulation substrate 30 is disposed on the substrate 10 and encapsulates the display unit 20. The encapsulation substrate 30 prevents external air and moisture from penetrating into the display unit 20.

[0021] The edges of the substrate 10 and the encapsulation substrate 30 are attached to each other by a sealing member 40 so that a space 25 between the substrate 10 and the encapsulation substrate 30 is sealed. A moisture absorbent, a filler, or the like may be filled in the space 25 as will be described later.

[0022] As shown in the embodiment in FIG. 2, instead of the encapsulation substrate 30 and the sealing member 40 as shown in the embodiment in FIG. 1, an encapsulation film 50 is formed on the display unit 20 to protect the display unit 20 from external air according to an as-

pect of the invention. The encapsulation film 50 is a thin film. The encapsulation film 50 may have a structure in which a layer formed of an inorganic material, such as silicon oxide or silicon nitride, and a layer formed of an organic material, such as epoxy or polyimide, are alternately formed. However, the present embodiment is not limited thereto and the encapsulation film 50 may have any structure as long as the encapsulation film 50 is a transparent thin film.

[0023] FIG. 3 is a plan view illustrating the display unit 20 of the organic light-emitting display apparatus FIG. 1 or FIG. 2 according to an aspect of the invention. FIG. 4 is a cross-sectional view taken along line A-A of FIG. 3. FIG. 5 is a cross-sectional view illustrating an organic layer 250 and a counter electrode 260 added to a pixel electrode of FIG. 4. FIG. 6 is a plan view illustrating a positional relationship between a via-hole 220 and a light-emitting portion 231 of the pixel electrode of FIG. 3.

[0024] Referring to FIGS. 3 through 6, a plurality of thin film transistors (TFTs) TRs are disposed on the substrate 10. The TFTs TRs are electrically connected to pixel electrodes 230 through the via-holes 220.

[0025] The substrate 10 may be formed of a transparent glass material including SiO₂ as a main component. Alternatively, the substrate 10 may be formed of an opaque material or a plastic material. However, the invention is not limited thereto.

[0026] A buffer layer 211 is formed on a top surface of the substrate 10. The TFTs TRs are formed on the buffer layer 211. The buffer layer 211 prevents the penetration of impurity elements and planarizes the top surface of the substrate 10. The buffer layer 211 may be formed of various materials. For example, the buffer layer 211 may be formed of an inorganic material, such as silicon oxide, silicon nitride, silicon oxynitride, aluminum oxide, aluminum nitride, titanium oxide, or titanium nitride, an organic material, such as polyimide, polyester, or acryl, or an organic-inorganic composite material thereof. The buffer layer 211 is not essential, and may be omitted if necessary.

[0027] Although only one driving TFT TR electrically connected to one of the pixel electrodes 230 is illustrated, this is for convenience of explanation. Although not illustrated in detail, a switching TFT, a capacitor, and the like may be further formed on the substrate 10. Also, various lines, such as scan lines, data lines, and driving lines, connected to the TFT and the capacitor may be further included in the organic light-emitting display apparatus.

[0028] A semiconductor active layer 212 is formed on the buffer layer 211. The semiconductor layer 212 may be formed of an inorganic semiconductor material such as amorphous silicon or polysilicon, but the present embodiment is not limited thereto and may be formed of an organic semiconductor material, an oxide semiconductor material, or the like. The semiconductor active layer 212 includes a source region 212b, a drain region 212c, and a channel region 212a disposed between the source region 212b and the drain region 212c.

[0029] A gate insulating layer 213 is formed on the buffer layer 211 to cover the semiconductor active layer 212. A gate electrode 214 is formed on the gate insulating layer 213. An interlayer insulating layer 215 is formed on the gate insulating layer 213 to cover the gate electrode 214. A source electrode 216 and a drain electrode 217 are formed on the interlayer insulating layer 215 and contact the source region 212b and the drain region 212c of the semiconductor active layer 212 through corresponding contact holes.

[0030] The structure of the TFT TR is not limited thereto, and the TFT TR may have various structures. For example, although the TFT TR has a top gate structure, the TFT TR may have a bottom gate structure in which the gate electrode 214 is formed under the semiconductor active layer 212. Of course, the TFT TR may have structures other than those described above.

[0031] A planarization layer 218 is formed to cover the TFTs TR. The planarization layer 218 reduces a height difference of the substrate 10 including the plurality of TFTs TR. The planarization layer 218 may be a single or multi-layered insulating layer having a flat top surface. The planarization layer 218 may be formed of at least one selected from the group consisting of polyimide, polyamide, acrylic resin, benzocyclobutene, and phenol resin.

[0032] Although not shown, a passivation layer may be further disposed on the source electrode 216 and the drain electrode 217.

[0033] Each of the via-holes 220 passes through the planarization layer 218 to expose the drain electrode 217 of each of the TFTs TR. Through the via-hole 220, each of the TFTs TR and each of the pixel electrodes 230 formed in a predetermined pattern on the planarization layer 218 are electrically connected to each other. Although the pixel electrode 230 is connected to the drain electrode 217 of the TFT TR in FIGS. 4 and 5, it is exemplary and the pixel electrode 230 may be electrically connected to the source electrode 216 through the via-hole 220.

[0034] The pixel electrode 230 includes the light-emitting portion 231 not covered by a pixel defining layer (PDL) 240, and a non-emitting portion 232 covered by the PDL 240. The non-emitting portion 232 may include a via-hole connecting portion 232b for connecting the light-emitting portion 231 and the via-hole 220, and a boundary portion 232a surrounding an edge of the light-emitting portion 231.

[0035] The PDL 240 is formed on the planarization layer 218 to cover the edge of the pixel electrode 230 electrically connected to the via-hole 220. The PDL 240 defines a pixel by covering the edge portion of the pixel electrode 230 to a predetermined thickness. Also, the PDL 240 prevents an arc from occurring at an end portion of the pixel electrode 230 by increasing a distance between the end portion of the pixel electrode 230 and the counter electrode 260, which will be explained later.

[0036] The organic layer 250 and the counter electrode

260 are sequentially formed on the pixel electrode 230. The organic layer 250 may be formed of a low or high molecular weight organic material. If the organic layer 250 is formed of a low molecular weight organic material, the organic layer 250 may be formed by stacking a hole injection layer (HIL), a hole transport layer (HTL), an emission layer (EML), an electron transport layer (ETL), and an electron injection layer (EIL) in a single or composite structure. Examples of the low molecular weight organic material may include copper phthalocyanine (CuPc), N,N'-Di(naphthalene-1-yl)-N,N'-diphenyl-benzidine (NPB), and tris-8-hydroxyquinoline aluminum (Alq3).

[0037] If the organic layer 250 is formed of a high molecular weight organic material, the organic layer 250 may include an HTL disposed on an EML toward the pixel electrode 230. The HTL may be formed of poly-(2,4)-ethylene-dihydroxy thiophene (PEDOT) or polyaniline (PANI). The EML is independently used for each of red, green, and blue pixels, and the HIL, the HTL, the ETL, and the EIL may be commonly used as common layers for red, green, and blue pixels.

[0038] Although the organic layer 250 is shown formed over only the pixel electrode 230 in FIG. 5, it is exemplary and the common layers may be formed to cover an entire pixel area, like the counter electrode 260. The organic layer 250 including the EML may have a color pattern that is formed by performing vacuum deposition, inkjet printing, spin coating, laser induced thermal imaging (LITI), or the like.

[0039] In particular, when a light-emitting material formed on a donor film is transferred to the pixel electrode 230 by using LITI, if the thickness of the PDL 240 surrounding the light-emitting portion 231 is high, the light-emitting material may not be smoothly transferred at the outer limit of the light-emitting portion 231 due to a great height difference between the light-emitting portion 231 and the PDL 240.

[0040] Even when the EML is not formed by using LITI, if the thickness of the PDL 240 is high, it is difficult to manufacture a thin display apparatus, which is currently increasingly in demand. In this regard, it is preferable that the thickness of the PDL 240 is as thin as possible.

[0041] When the thickness of the PDL 240 is low, if the via-hole 220 is formed too close to the edge portion of the pixel electrode 230 (i.e., too close to the outer limit of the light-emitting portion 231 of the pixel electrode 230), the PDL 240 formed on the pixel electrode 230 may sink into the via-hole 220 due to the proximity of the via-hole 220, thereby failing to maintain its thickness. Accordingly, the outer limit of the light-emitting portion 231 of the pixel electrode 230 becomes unclear, thereby reducing the overall flatness of the pixel. As a result, if the pattern for the EML is formed by LITI, vacuum deposition, or the like, the outer limit of the pattern for the EML becomes unclear, thereby lowering display quality.

[0042] To solve this problem, according to the organic light-emitting display apparatus of the present embodi-

ment, the via-hole 220 is formed at a position farthest from the outer limit of the light-emitting portion 231 of the pixel electrode 230 formed near and around the via-hole 220.

[0043] FIG. 6 is a plan view illustrating a positional relationship between light-emitting portions 231-1, 231-2, 231-3, ... of the pixel electrodes 230 and the via-holes 220. PDLs 240 and pixel defining layer forming portions surrounded by the PDLs 240 are not shown in FIG. 6. Referring to FIGS. 3 and 6, the via-holes 220 are formed at positions farthest from the light-emitting portions 231-1, 231-2, 231-3, ... of the pixel electrodes 230 formed near and around the via-holes 220.

[0044] Specifically, if patterns for the light-emitting portions 231 of the pixel electrodes 230 are regularly arranged in a first direction (x direction) and a second direction (y direction) that perpendicularly intersects the first direction, each of the via-holes 220 may be formed at a position farthest from the outer limits of two light-emitting portions 231-1 and 231-3 that are adjacent in the second direction and disposed around a via-hole 220 and from the outer limits of two light-emitting portions 231-1 and 231-3 that are adjacent in the first direction and disposed around the via-hole 220.

[0045] As shown in FIG. 6, the via-hole 220 may be formed at an intersection of straight lines $\ell 1$ and $\ell 2$. The straight line $\ell 1$ connects central points between the two light-emitting portions 231-1 and 231-2 that are adjacent in the first direction and disposed around the via-hole 220. The straight line $\ell 2$ connects central points between the two light-emitting portions 231-1 and 231-3 that are adjacent in the second direction and disposed around the via-hole 220. In detail, the via-hole 220 may be formed at a perpendicular intersection between the straight line $\ell 1$ and the straight line $\ell 2$. Meanwhile, while shown as straight, it is understood that one or both of the lines $\ell 1$ and $\ell 2$ can be other than straight in other aspects, depending on the placement of the light-emitting portions 231-1, 231-2, 231-3.

[0046] Also, the via-hole 220 may be formed at an intersection of the light-emitting portions 231-1, 231-2, 231-3, and 231-4 which are diagonally adjacent and disposed around the via-hole 220. In detail, as shown in FIG. 6, the via-hole 220 may be formed at an intersection of straight lines $\ell 3$ and $\ell 4$. The straight line $\ell 3$ connects the two light-emitting portions 231-1 and 231-4 that are diagonally adjacent and disposed around the via-hole 220. The straight line $\ell 4$ connects the two light-emitting portions 231-2 and 231-3 that are diagonally adjacent and disposed around the via-hole 220.

[0047] Also, referring to FIGS. 3 and 6, the light-emitting portion may be arranged in a first grid pattern, and the via-hole 220 may be arranged in a second grid pattern offset from the first grid pattern.

[0048] Referring to FIGS. 3 and 4, distances "d" between the via-holes 220 and the outer limits of the light-emitting portions 231 of the pixel electrodes 230 disposed near and around the via-holes 220 are constant, and are

determined so that each of the via-holes 220 is farthest from the outer limit of an adjacent light-emitting portion 231.

[0049] Meanwhile, as shown in FIGS. 3 and 6, the light-emitting portions 231 of the pixel electrodes 230 are not disposed on a straight line B1-B1 formed by connecting each of the via-holes 220 and via-holes 220 that are adjacent to the corresponding via-hole 200 in the first direction, and are not disposed on a straight line B2-B2 formed by connecting each of the via-holes 220 and via-holes 220 that are adjacent to the corresponding via-hole 220 in the second direction, in order that each of the via-holes 220 is farthest from adjacent light-emitting portions 231.

[0050] Accordingly, even if the PDL 240 is thin and falls down into the via-hole 220, since the thickness of the PDL 240 at the outer limit of the light-emitting portion 231 is maintained, the light-emitting area may be clearly defined. As a result, if the pattern for the EML is formed by LITI, a vacuum deposition, or the like, the outer limit of the pattern for the EML may be clearly maintained, the flatness of the pixel may be substantially maintained, and display quality may be improved.

[0051] The thickness of the PDL 240 of the organic light-emitting display apparatus is low. For example, the thickness of the PDL 240 may be equal to or greater than 50 nm (500 angstroms (A)) and equal to or less than 500 nm (5000 A). If the thickness of the PDL 240 is less than 50 nm (500 A), it is difficult to define the pixel, and if the thickness of the PDL 240 is greater than 500 nm (5000 A), smooth transfer of the EML by using LITI or the like may not be achieved due to a height difference between the PDL 240 and the light-emitting portion 231.

[0052] Referring to FIG. 4, since the thickness of the PDL 240 is low, a height "h2" between a bottom surface of the substrate 10 and a portion of the PDL 240 formed over the via-hole 220 is lower than a height "h1" between the bottom surface of the substrate 10 and a surface of the pixel electrode 230 formed on the light-emitting portion 231. This is because the PDL 240 which is relatively thin may not sufficiently fill a stepped portion formed in the via-hole 220. However, since the via-hole 220 is sufficiently far from the outer limit of the light-emitting portion 231 of the pixel electrode 230, although the portion of the PDL 240 formed over the via-hole 220 sinks and thus fails to maintain its thickness, the thickness of a portion of the PDL 240 formed at the outer limit of the light-emitting portion 231 that is spaced apart by the distance "d" from the via-hole 220 may be maintained.

[0053] The pixel electrode 230 of the organic light-emitting display apparatus may function as an anode and the counter electrode 260 may function as a cathode. Of course, polarities of the pixel electrode 230 and the counter electrode 260 may be reversed.

[0054] The pixel electrode 230 may be a reflective electrode, and the counter electrode 260 may be a transparent electrode. Accordingly, the display unit 20 is a top emission display unit in which an image is formed in a

direction toward the counter electrode 260.

[0055] To this end, the pixel electrode 230 may include a reflective layer formed of at least one selected from the group consisting of silver (Ag), magnesium (Mg), aluminum (Al), platinum (Pt), palladium (Pd), gold (Au), nickel (Ni), neodymium (Nd), iridium (Ir), chromium (Cr), lithium (Li), calcium (Ca), or a compound thereof, and a material having a high work function such as indium tin oxide (ITO), indium zinc oxide (IZO), ZnO, or In₂O₃. The counter electrode 260 may be formed of a metal having a low work function such as Ag, Mg, Al, Pt, Pd, Au, Ni, Nd, Ir, Cr, Li, Ca, or an alloy thereof.

[0056] However, the present embodiment is not limited thereto, and the pixel electrode 230 may be a transparent electrode. In this case, the pixel electrode 230 may be formed of a material having a high work function, such as indium tin oxide (ITO), IZO, ZnO, or In₂O₃, without including a reflective layer.

[0057] As described above, the organic light-emitting display apparatus according to aspects the present invention allows that, even if the thickness of a portion of a pixel defining layer formed near a via-hole is not maintained, the thickness of a portion of the pixel defining layer formed at the outer limit of a light-emitting portion may be maintained. Moreover, aspects allow a light-emitting area to be clearly defined. Also, aspects of the invention allow, when a pattern for an EML is formed by vacuum deposition, laser induced thermal imaging, or the like, display quality to be improved.

Claims

1. An organic light-emitting display apparatus comprising:

a plurality of thin film transistors;
 a planarization layer (218) covering the plurality of thin film transistors;
 a plurality of pixel electrodes (230) formed on the planarization layer (218), each of the pixel electrodes (230) being connected to a corresponding one of the plurality of thin film transistors using a via-hole (220) passing through the planarization layer (218) and having a light-emitting portion (231) and a non-emitting portion (232);
 a pixel defining layer (240) formed on the planarization layer (218) to respectively cover each of the via-holes (220) and the non-emitting portions (232);
 organic layers (250), each organic layer (250) comprising an emission layer and being disposed in a corresponding one of the light-emitting portions (231); wherein the thickness of the pixel defining layer (240) is larger than the thickness of the organic layers (250); and
 a counter electrode (260) disposed on each of

the organic layers (250),

characterised in that

each of the via-holes (220) is located at a point farthest from each of the light-emitting portions (231) surrounding the via-hole (220).

2. The organic light-emitting display apparatus of claim 1, wherein the plurality of pixel electrodes (230) are patterned in a first direction and a second direction perpendicular to the first direction, and each of the plurality of via-holes (220) is formed at a position farthest from outer limits of the light-emitting portions (231) of the plurality of pixel electrodes (230) that are adjacent in the first direction and the second direction and disposed around the via-hole.
3. The organic light-emitting display apparatus of claim 1 or 2, wherein each of the plurality of via-holes (220) is formed at an intersection of first and second straight lines, the first straight line connecting central points between adjacent pairs of the light-emitting portions (231) that are adjacent in the first direction and disposed around the via-hole (220) and the second straight line connecting central points between adjacent pairs of the light-emitting portions (231) that are adjacent in the second direction and disposed around the via-hole (220).
4. The organic light-emitting display apparatus of claim 3, wherein the first straight line and the second straight line perpendicularly intersect each other.
5. The organic light-emitting display apparatus of one of the preceding claims, wherein each via-hole (220) is disposed substantially at a common point between diagonally adjacent pairs of the light-emitting portions (231).
6. The organic light-emitting display apparatus of one of the preceding claims, wherein the light-emitting portions are arranged in a first grid pattern and the via-holes are arranged in a second grid pattern offset from the first grid pattern.
7. The organic light-emitting display apparatus of one of the preceding claims, wherein the light-emitting portions (231) are not disposed on a straight line formed by connecting adjacent via-holes (220).
8. The organic light-emitting display apparatus of one of the preceding claims, wherein, relative to the substrate (10), a height of a portion of the pixel defining layer (240) formed over each of the plurality of via-holes (220) is lower than a height of a portion of each of the pixel electrodes (230) formed on the light-emitting portion (231).

9. The organic light-emitting display apparatus of one of the preceding claims, wherein a thickness of the pixel defining layer (240) is at or between 50 nm (500 Å) and 500 nm (5000 Å).
10. The organic light-emitting display apparatus of one of the preceding claims, wherein the pixel defining layer (240) is substantially planar except at portions covering the via-holes (220).
11. The organic light-emitting display apparatus of one of the preceding claims, wherein via-hole connecting portions (232b) of the plurality of pixel electrodes (230) have the same pattern.

Patentansprüche

1. Organische lichtemittierende Anzeigevorrichtung, aufweisend:

eine Vielzahl von Dünnschichttransistoren;
 eine Planarisierungsschicht (218), die die Vielzahl der Dünnschichttransistoren bedeckt;
 eine Vielzahl von Pixelelektroden (230), die auf der Planarisierungsschicht (218) ausgebildet sind, wobei jede der Pixelelektroden (230) mittels eines Durchgangslochs (220), das durch die Planarisierungsschicht (218) hindurchgeht, mit einem korrespondierenden Dünnschichttransistor der Vielzahl der Dünnschichttransistoren verbunden ist und einen lichtemittierenden Abschnitt (231) und einen nicht-emittierenden Abschnitt (232) aufweist;
 eine Pixeldefinitionsschicht (240), die derart auf der Planarisierungsschicht (218) ausgebildet ist, dass sie jeweils jedes der Durchgangslöcher (220) und jeden der nicht-emittierenden Abschnitte (232) bedeckt;
 organische Schichten (250), wobei jede organische Schicht (250) eine Emissionsschicht aufweist und in einem korrespondierenden lichtemittierenden Abschnitt (231) der lichtemittierenden Abschnitte (231) angeordnet ist, wobei die Dicke der Pixeldefinitionsschicht (240) größer als die Dicke der organischen Schichten (250) ist; und
 eine Gegenelektrode (260), die auf jeder der organischen Schichten (250) angeordnet ist,
dadurch gekennzeichnet, dass
 jedes der Durchgangslöcher (220) an einem Punkt positioniert ist, der am weitesten entfernt von jedem der lichtemittierenden Abschnitte (231) ist, die das Durchgangsloch (220) umgeben.

2. Organische lichtemittierende Anzeigevorrichtung nach Anspruch 1, wobei die Vielzahl der Pixelelektroden (230) in einer ersten Richtung und einer zur ersten Richtung senkrechten zweiten Richtung gemustert ist, und wobei jedes aus der Vielzahl der Durchgangslöcher (220) in einer Position ausgebildet ist, die am weitesten entfernt von Außengrenzen der lichtemittierenden Abschnitte (231) der Vielzahl der Pixelelektroden (230) ist, die in der ersten Richtung und der zweiten Richtung benachbart sind und um das Durchgangsloch (220) herum angeordnet sind.
3. Organische lichtemittierende Anzeigevorrichtung nach Anspruch 1 oder 2, wobei jedes aus der Vielzahl der Durchgangslöcher (220) an einem Schnittpunkt einer ersten und einer zweiten geraden Linie ausgebildet ist, wobei die erste gerade Linie mittlere Punkte zwischen benachbarten Paaren der lichtemittierenden Abschnitte (231) verbindet, die in der ersten Richtung benachbart sind und um das Durchgangsloch (220) herum angeordnet sind, und wobei die zweite gerade Linie mittlere Punkte zwischen benachbarten Paaren der lichtemittierenden Abschnitte (231) verbindet, die in der zweiten Richtung benachbart sind und um das Durchgangsloch (220) herum angeordnet sind.
4. Organische lichtemittierende Anzeigevorrichtung nach Anspruch 3, wobei sich die erste gerade Linie und die zweite gerade Linie senkrecht schneiden.
5. Organische lichtemittierende Anzeigevorrichtung nach einem der vorhergehenden Ansprüche, wobei jedes Durchgangsloch (220) im Wesentlichen an einem gemeinsamen Punkt zwischen diagonal benachbarten Paaren der lichtemittierenden Abschnitte (231) angeordnet ist.
6. Organische lichtemittierende Anzeigevorrichtung nach einem der vorhergehenden Ansprüche, wobei die lichtemittierenden Abschnitte in einem ersten Gittermuster angeordnet sind und die Durchgangslöcher in einem zweiten Gittermuster angeordnet sind, das zum ersten Gittermuster versetzt ist.
7. Organische lichtemittierende Anzeigevorrichtung nach einem der vorhergehenden Ansprüche, wobei die lichtemittierenden Abschnitte (231) nicht auf einer geraden Linie angeordnet sind, die durch Verbinden benachbarter Durchgangslöcher (220) ausgebildet wird.
8. Organische lichtemittierende Anzeigevorrichtung nach einem der vorhergehenden Ansprüche, wobei in Bezug auf das Substrat (10) eine Höhe eines Abschnitts der Pixeldefinitionsschicht (240), der über jedem aus der Vielzahl der Durchgangslöcher (220)

ausgebildet ist, kleiner ist als eine Höhe eines Abschnitts von jeder der Pixelelektroden (230), der auf dem lichtemittierenden Abschnitt (231) ausgebildet ist.

9. Organische lichtemittierende Anzeigevorrichtung nach einem der vorhergehenden Ansprüche, wobei eine Dicke der Pixeldefinitionsschicht (240) 50 nm (500 Å) oder 500 nm (5000 Å) beträgt oder zwischen 50 nm (500 Å) und 500 nm (5000 Å) beträgt.
10. Organische lichtemittierende Anzeigevorrichtung nach einem der vorhergehenden Ansprüche, wobei die Pixeldefinitionsschicht (240) außer an Abschnitten, die die Durchgangslöcher (220) bedecken, im Wesentlichen eben ist.
11. Organische lichtemittierende Anzeigevorrichtung nach einem der vorhergehenden Ansprüche, wobei die Durchgangsloch-Verbindungsabschnitte (232b) der Vielzahl der Pixelelektroden (230) das gleiche Muster aufweisen.

Revendications

1. Dispositif organique d'affichage électroluminescent comprenant :

une pluralité de transistors à couches minces ;
 une couche (218) de planarisation couvrant la pluralité de transistors à couches minces ;
 une pluralité d'électrodes (230) de pixel formée sur la couche (218) de planarisation, chacune des électrodes (230) de pixel étant connectée à l'un, correspondant, de la pluralité de transistors à couches minces en utilisant un trou traversant (220) passant à travers la couche (218) de planarisation et ayant une partie électroluminescente (231) et une partie non émissive (232) ;
 une couche (240) de définition de pixels formée sur la couche (218) de planarisation pour couvrir respectivement chacun des trous traversants (220) et chacune des parties non émissives (232) ;

des couches organiques (250), chaque couche organique (250) comprenant une couche d'émission et étant disposée dans l'une, correspondante, des parties électroluminescentes (231), dans lequel l'épaisseur de la couche (240) de définition de pixels est plus grande que l'épaisseur des couches organiques (250) ; et une contre-électrode (260) disposée sur chacune des couches organiques (250),

caractérisé en ce que chacun des trous traversants (220) est situé en un point le plus éloigné de chacune des parties électroluminescentes (231) entourant le trou traversant (220).

2. Dispositif organique d'affichage électroluminescent selon la revendication 1, dans lequel la pluralité d'électrodes (230) de pixel est structurée en motif dans une première direction et une seconde direction perpendiculaire à la première direction, et chacun de la pluralité de trous traversants (220) est formé à une position la plus éloignée des limites extérieures des parties électroluminescentes (231) de la pluralité d'électrodes (230) de pixel qui sont adjacentes dans la première direction et la seconde direction et disposées autour du trou traversant.

3. Dispositif organique d'affichage électroluminescent selon la revendication 1 ou 2, dans lequel chacun de la pluralité de trous traversants (220) est formé à une intersection de première et seconde lignes droites, la première ligne droite reliant des points centraux entre des paires adjacentes des parties électroluminescentes (231) qui sont adjacentes dans la première direction et disposées autour du trou traversant (220) et la seconde ligne droite reliant des points centraux entre des paires adjacentes des parties électroluminescentes (231) qui sont adjacentes dans la seconde direction et disposées autour du trou traversant (220).

4. Dispositif organique d'affichage électroluminescent selon la revendication 3, dans lequel la première ligne droite et la seconde ligne droite se coupent perpendiculairement l'une à l'autre.

5. Dispositif organique d'affichage électroluminescent selon l'une des revendications précédentes, dans lequel chaque trou traversant (220) est disposé pratiquement au niveau d'un point commun entre des paires diagonalement adjacentes des parties électroluminescentes (231).

6. Dispositif organique d'affichage électroluminescent selon l'une des revendications précédentes, dans lequel les parties électroluminescentes sont agencées en un premier motif de grille et les trous traversants sont agencés en un second motif de grille décalé par rapport au premier motif de grille.

7. Dispositif organique d'affichage électroluminescent selon l'une des revendications précédentes, dans lequel les parties électroluminescentes (231) ne sont pas disposées sur une ligne droite formée en reliant des trous traversants (220) adjacents.

8. Dispositif organique d'affichage électroluminescent selon l'une des revendications précédentes, dans lequel, par rapport au substrat (10), la hauteur d'une partie de la couche (240) de définition de pixels formée sur chacun de la pluralité de trous traversants (220) est plus basse que la hauteur d'une partie de chacune des électrodes (230) de pixel formée sur la

partie électroluminescente (231).

9. Dispositif organique d'affichage électroluminescent selon l'une des revendications précédentes, dans lequel l'épaisseur de la couche (240) de définition de pixels est de, ou entre, 50 nm (500 Å) et 500 nm (5000 Å). 5
10. Dispositif organique d'affichage électroluminescent selon l'une des revendications précédentes, dans lequel la couche (240) de définition de pixels est pratiquement plane exceptée au niveau de parties couvrant les trous traversants (220). 10
11. Dispositif organique d'affichage électroluminescent selon l'une des revendications précédentes, dans lequel des parties (232b) reliant les trous traversants de la pluralité d'électrodes (230) de pixels ont le même motif. 15

20

25

30

35

40

45

50

55

FIG. 1

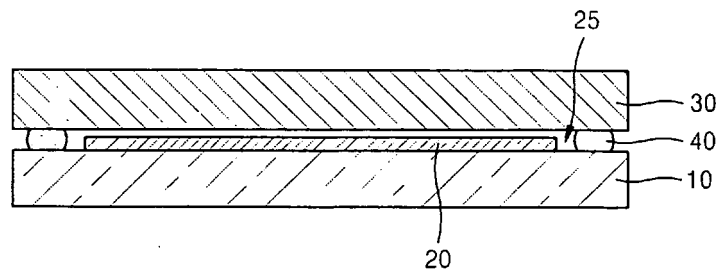

FIG. 2

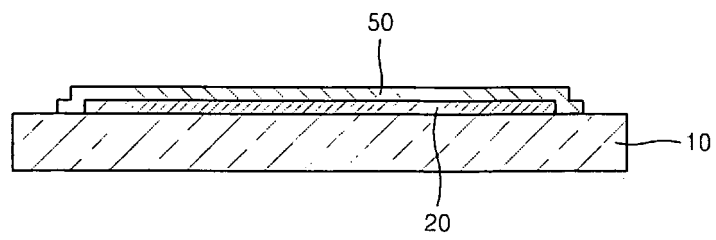

FIG. 3

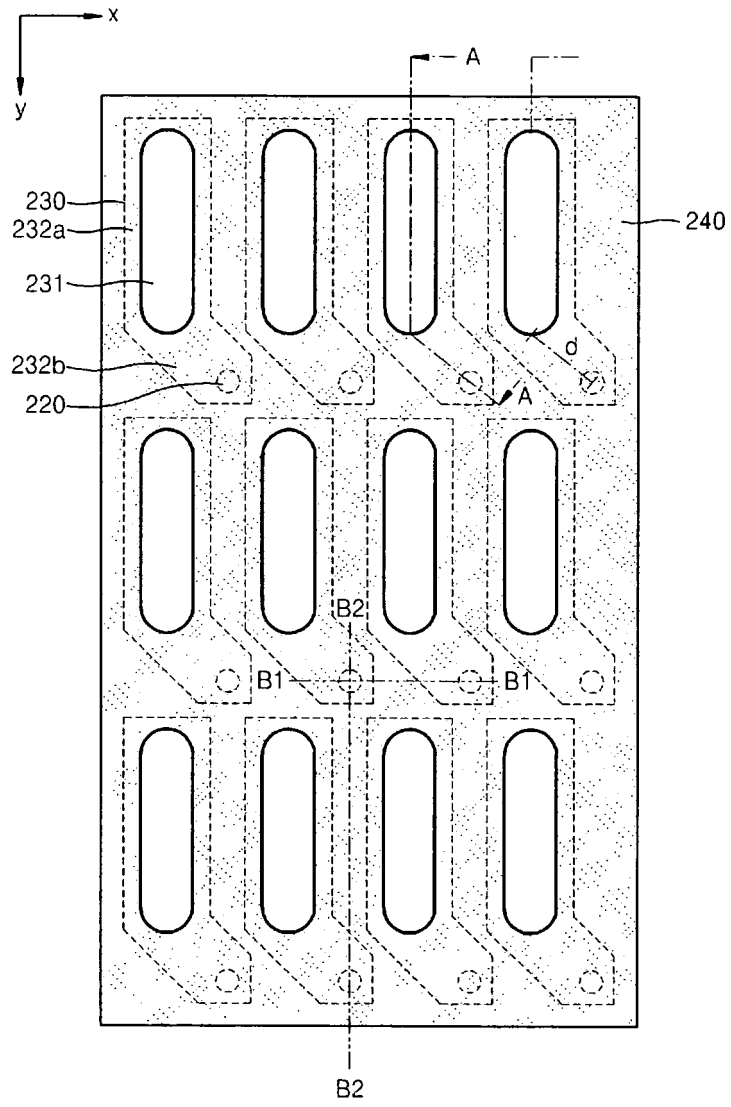

FIG. 4

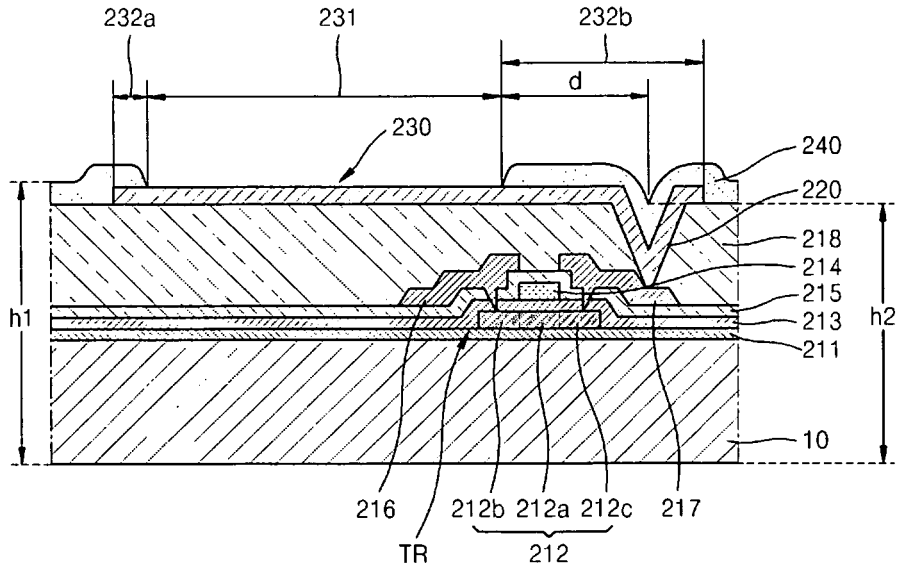

FIG. 5

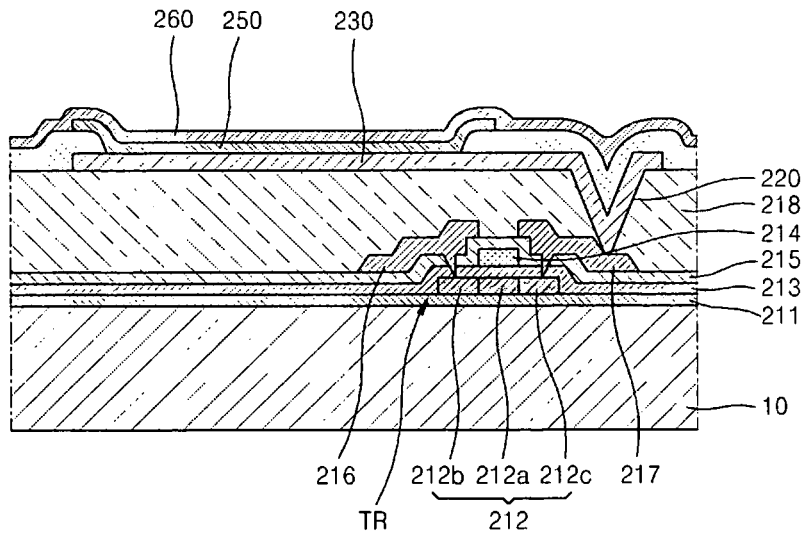
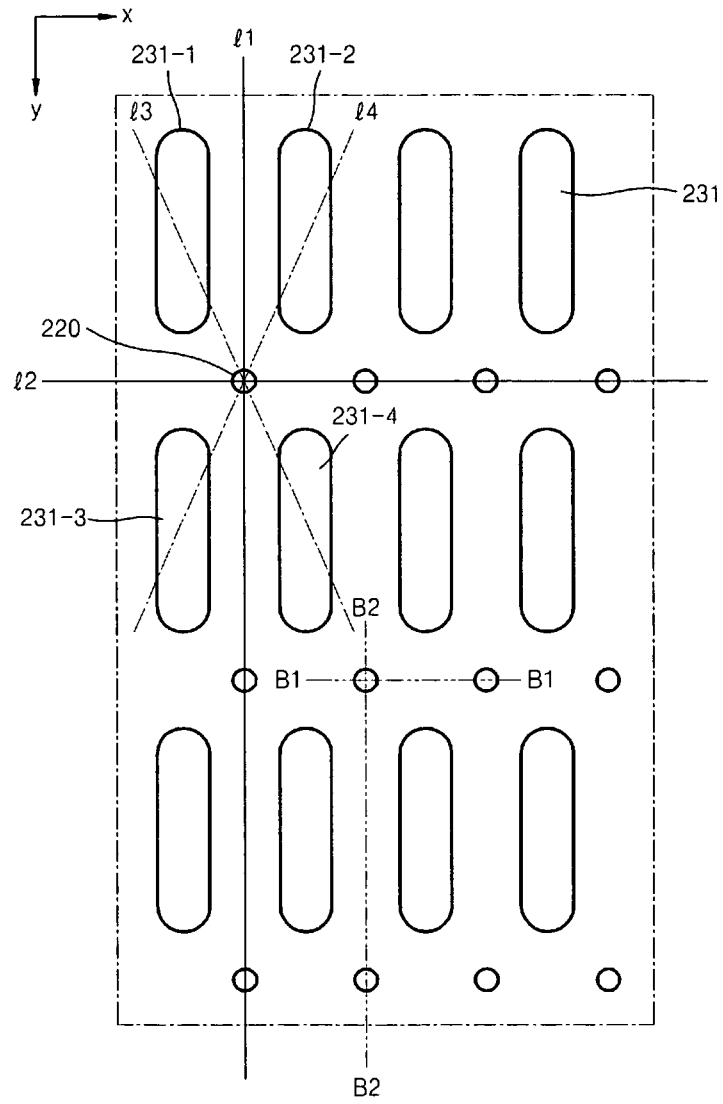

FIG. 6



REFERENCES CITED IN THE DESCRIPTION

This list of references cited by the applicant is for the reader's convenience only. It does not form part of the European patent document. Even though great care has been taken in compiling the references, errors or omissions cannot be excluded and the EPO disclaims all liability in this regard.

Patent documents cited in the description

- US 20060082292 A1 [0003]

专利名称(译)	有机发光显示装置		
公开(公告)号	EP2381479B1	公开(公告)日	2013-01-23
申请号	EP2011163504	申请日	2011-04-21
[标]申请(专利权)人(译)	三星显示有限公司		
申请(专利权)人(译)	三星移动显示器有限公司.		
当前申请(专利权)人(译)	三星DISPLAY CO. , LTD.		
[标]发明人	SUN JIN WON SUH MIN CHUL LEE JAE HO KANG TAE MIN NOH SOK WON		
发明人	SUN, JIN-WON SUH, MIN-CHUL LEE, JAE-HO KANG, TAE-MIN NOH, SOK-WON		
IPC分类号	H01L27/32		
CPC分类号	H01L27/3246 H01L27/3248 H01L2251/558		
优先权	1020100038531 2010-04-26 KR 1020110029857 2011-03-31 KR		
其他公开文献	EP2381479A1		
外部链接	Espacenet		

摘要(译)

一种有机发光显示装置，包括：多个薄膜晶体管 (TFT) ;覆盖多个TFT的平坦化层;形成在平坦化层上的多个像素电极，每个像素电极使用穿过平坦化层并具有发光部分和非发光部分的通孔连接到多个TFT中的相应一个TFT每个通孔位于距通孔周围的每个发光部分最远的点上;形成在平坦化层上的像素限定层分别覆盖每个通孔和非发光部分;有机层，每个有机层包括发光层并设置在相应的一个发光部分中;和设置在每个有机层上的对电极。

FIG. 1

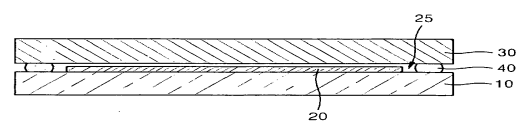

FIG. 2

