



(11) **EP 2 365 557 A2**

(12) **EUROPEAN PATENT APPLICATION**

(43) Date of publication:  
**14.09.2011 Bulletin 2011/37**

(51) Int Cl.:  
**H01L 51/52<sup>(2006.01)</sup> H01L 27/32<sup>(2006.01)</sup>**

(21) Application number: **11250277.8**

(22) Date of filing: **10.03.2011**

(84) Designated Contracting States:  
**AL AT BE BG CH CY CZ DE DK EE ES FI FR GB GR HR HU IE IS IT LI LT LU LV MC MK MT NL NO PL PT RO RS SE SI SK SM TR**  
Designated Extension States:  
**BA ME**

- **Lee, Joo-Hyeon**  
**Yongin-City**  
**Gyeonggi-Do 446-711 (KR)**
- **Chung, Jin-Koo**  
**Yongin-City**  
**Gyeonggi-Do 446-711 (KR)**

(30) Priority: **10.03.2010 KR 20100021384**

(74) Representative: **Mounteney, Simon James**  
**Marks & Clerk LLP**  
**90 Long Acre**  
**London**  
**WC2E 9RA (GB)**

(71) Applicant: **Samsung Mobile Display Co., Ltd.**  
**Yongin-city, Gyeonggi-do 446-711 (KR)**

(72) Inventors:  
• **Park, Byoung -Hee**  
**Yongin-City**  
**Gyeonggi-Do 446-711 (KR)**

(54) **Organic light emitting display device and method of manufacturing the same**

(57) An organic light emitting display device having high transmittance with respect to external light and a method of manufacturing the same. The organic light emitting display device includes a substrate; a plurality of pixels formed on the substrate, each of the pixels including a first region that emits light and a second region that transmits external light; a plurality of thin film transistors disposed in the first region of each pixel; a plurality

of first electrodes disposed in the first region of each pixel and electrically connected to the thin film transistors, respectively; a second electrode formed opposite to the plurality of first electrodes and comprising a plurality of transmission windows corresponding to the second regions; and an organic layer formed between the first electrodes and the second electrode. The transmission windows can be formed in the second electrode, that is, a cathode.

**FIG. 3**

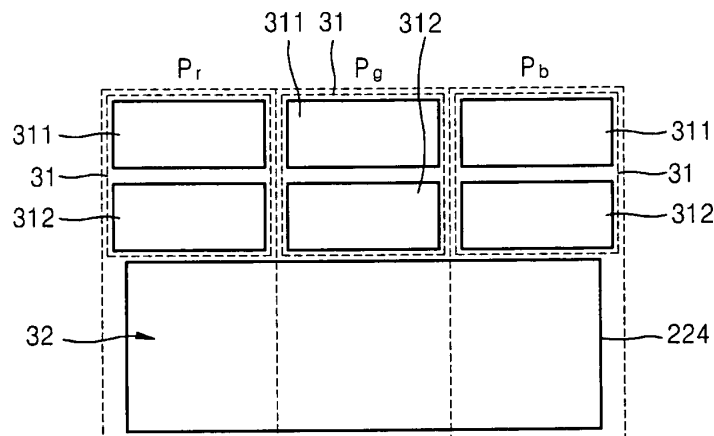

**EP 2 365 557 A2**

## Description

### BACKGROUND

#### 1. Field

[0001] An aspect of the present invention relates to an organic light emitting display device, and more particularly, to a transparent organic light emitting display device and a method of manufacturing the same.

#### 2. Description of the Related Art

[0002] As organic light emitting display devices have superior characteristics such as wide viewing angle, high contrast ratio, short response time, and low power consumption, they are widely used in personal portable devices such as MP3 players, mobile phones, television sets, etc.

[0003] Also, transparent organic light emitting display devices have been constructed using transparent thin film transistors and transparent organic light emitting devices.

[0004] However, since a cathode of the transparent organic light emitting display device is formed of a metal, there is a limit in increasing the transmittance of the transparent organic light emitting display device.

### SUMMARY

[0005] An aspect of the present invention provides a transparent organic light emitting display device having high transmittance with respect to external light and a method of manufacturing the transparent organic light emitting display device.

[0006] According to another aspect of the present invention, there is also provided an organic light emitting display device including a cathode having transmission windows and that are formed in a simple way, and a method of manufacturing the organic light emitting display device.

[0007] According to an aspect of the present invention, there is provided an organic light emitting display device including a substrate; a plurality of pixels formed on the substrate, each of the pixels having a first region that emits light and a second region that transmits external light; a plurality of thin film transistors disposed in the first region of the pixel; a plurality of first electrodes disposed in the first region of the pixel and electrically connected to the thin film transistors, respectively; a second electrode formed opposite to the plurality of first electrodes and comprising a plurality of transmission windows corresponding to the second regions; and an organic layer formed between the first electrodes and the second electrode.

[0008] According to an aspect of the present invention, a decrease in the transmittance of the second region where external light is transmitted may be prevented as

much as possible. Thus, a user may easily observe external images.

[0009] According to another aspect of the present invention, the transmission windows may be formed in the second electrode by using a simple method.

[0010] At least some of the above and other features of the invention are set out in the appended claims.

[0011] Additional aspects and/or advantages of the invention will be set forth in part in the description which follows and, in part, will be obvious from the description, or may be learned by practice of the invention.

### BRIEF DESCRIPTION OF THE DRAWINGS

[0012] These and/or other aspects and advantages of the invention will become apparent and more readily appreciated from the following description of the following embodiments, taken in conjunction with the accompanying drawings of which:

FIG. 1 is a schematic cross-sectional view of an organic light emitting display device according to an embodiment of the present invention;

FIG. 2 is a schematic plan view of an organic light emitting display device according to an embodiment of the present invention;

FIG. 3 is a schematic plan view of an organic light emitting display device according to another embodiment of the present invention;

FIG. 4 is a cross-sectional view of a pixel of an organic light emitting display device according to an embodiment of the present invention;

FIG. 5 is a plan view of a mask for forming a second electrode having a transmission window, according to an embodiment of the present invention;

FIGS. 6A through 6D are plan views illustrating an operation of forming a second electrode by using the mask illustrated in FIG. 5;

FIG. 7 is a plan view of a mask for forming a second electrode having a transmission window, according to an embodiment of the present invention;

FIG. 8 is a plan view of a mask for forming a second electrode having a transmission window, according to another embodiment of the present invention; and

FIG. 9 is a cross-sectional view of a pixel of an organic light emitting display device according to another embodiment of the present invention.

### DETAILED DESCRIPTION

[0013] Reference will now be made in detail to the present embodiments of the present invention, examples of which are illustrated in the accompanying drawings, wherein like reference numerals refer to the like elements throughout. The embodiments are described below in order to explain the present invention by referring to the figures.

[0014] Here, it is to be understood that where is stated

herein that one film or layer is "formed on" or "disposed on" a second layer or film, the first layer or film may be formed or disposed directly on the second layer or film or there may be intervening layers or films between the first layer or film and the second layer or film. Further, as used herein, the term "formed on" is used with the same meaning as "located on" or "disposed on" and is not meant to be limiting regarding any particular fabrication process.

**[0015]** FIG. 1 is a schematic cross-sectional view of an organic light emitting display device according to an embodiment of the present invention. Referring to FIG. 1, the organic light emitting display device according to an embodiment of the present invention includes a substrate 1 and a display unit 2 placed on the substrate 1. External light enters the organic light emitting display device via the display unit 2 and the substrate 1.

**[0016]** As will be described later, the display unit 2 transmits external light. Referring to FIG. 1, the display unit 2 allows a user positioned below the substrate 1 to view external images beyond the display unit 2. Although a bottom-emission type organic light emitting display device in which images on the display unit 2 are displayed toward the substrate 1 as illustrated in FIG. 1, aspects of the present invention are not limited thereto, and may be equally applied to a top-emission type organic light emitting display device in which images on the display unit 2 are displayed in a direction opposite to the substrate 1.

**[0017]** FIG. 1 illustrates two adjacent pixels, namely, a first pixel P1 and a second pixel P2, of the organic light emitting display device according to an aspect of the present invention.

**[0018]** Each of the first and second pixels P1 and P2 includes a first region 31 and a second region 32.

**[0019]** An image is displayed on the display unit 2 in the first region 31, and external light passes through the display unit 2 in the second region 32.

**[0020]** In other words, since each of the first and second pixels P1 and P2 includes the first region 31 where images are displayed and the second region 32 which transmits external light, a user can see an external image through the second region 32 when the user does not see the image displayed through the first region 31.

**[0021]** Thus, the second region 32 does not include devices such as a thin film transistor, a capacitor, and an organic light emitting device, and thus external light transmittance may be maximized and distortion of a transmitted image due to interference of the devices such as a thin film transistor, a capacitor, and an organic light emitting device may be prevented as much as possible.

**[0022]** FIG. 2 is a schematic plan view of a red pixel P<sub>r</sub>, a green pixel P<sub>g</sub>, and a blue pixel P<sub>b</sub> that are adjacent to one another.

**[0023]** Each of the red, green, and blue pixels P<sub>r</sub>, P<sub>g</sub>, and P<sub>b</sub> includes a circuit region 311 and an emission region 312 in the first region 31. The circuit region 311 and the emission region 312 are adjacent to each other.

**[0024]** The second region 32 that transmits external light is adjacent to the first region 31.

**[0025]** As illustrated in FIG. 2, independent second regions 32 may be included in the red, green, and blue pixels P<sub>r</sub>, P<sub>g</sub>, and P<sub>b</sub>, respectively. Alternatively, as illustrated in FIG. 3, second regions 32 may be connected to one another across the red, green, and blue pixels P<sub>r</sub>, P<sub>g</sub>, and P<sub>b</sub>. In the embodiment of FIG. 3, an area of the second region 32 through which external light passes is increased, and thus the transmittance of the entire display unit 2 may be increased.

**[0026]** Although the second regions 32 of the red, green, and blue pixels P<sub>r</sub>, P<sub>g</sub>, and P<sub>b</sub> are integrally connected to one another in FIG. 3, the aspects of the present invention are not limited thereto, and the second regions of only two adjacent pixels from among the red, green, and blue pixels P<sub>r</sub>, P<sub>g</sub>, and P<sub>b</sub> may be connected to each other.

**[0027]** FIG. 4 illustrates a cross-section of the red, green, or blue pixel P<sub>r</sub>, P<sub>g</sub>, or P<sub>b</sub> illustrated in FIGS. 2 and 3.

**[0028]** As illustrated in FIG. 4, a thin film transistor TR is arranged in the circuit region 311. However, a pixel circuit including the thin film transistor TR may be also included in the circuit region 311. Alternatively, the circuit region 311 may further include a plurality of thin film transistors TR and a storage capacitor. In this case, wires such as scan lines, data lines, and V<sub>dd</sub> lines connected to the thin film transistors TR and the storage capacitor may be further included in the circuit region 311.

**[0029]** An organic light emitting diode EL may be disposed in the emission region 312. The organic light emitting diode EL is electrically connected to the thin film transistor TR of the circuit region 311.

**[0030]** A buffer layer 211 is formed on the substrate 1, and a pixel circuit including the thin film transistor TR is formed on the buffer layer 211.

**[0031]** First, a semiconductor active layer 212 is formed on the buffer layer 211.

**[0032]** The buffer layer 211 is formed of a transparent insulation material and prevents impurity elements from penetrating into the substrate 1 and planarizes a surface of the substrate 1. The buffer layer 211 may be formed of any of various materials that can perform the functions described above. For example, the buffer layer 211 may be formed of an inorganic material such as silicon oxide, silicon nitride, silicon oxynitride, aluminum oxide, aluminum nitride, titanium oxide, or titanium nitride, an organic material such as polyimide, polyester, or acryl, or stacks of these materials. The buffer layer 211 is not an essential element and may not be formed at all.

**[0033]** The semiconductor active layer 212 may be formed of polycrystal silicon, but is not limited thereto and may be formed of a semiconductor oxide. For example, the semiconductor active layer 212 may be a G-I-Z-O layer [a(In<sub>2</sub>O<sub>3</sub>)b(Ga<sub>2</sub>O<sub>3</sub>)c(ZnO) layer] (where a, b, and c are natural numbers that respectively satisfy a ≥ 0, b ≥ 0, and c > 0). When the semiconductor active layer 212 is

formed of a semiconductor oxide, light transmittance in the circuit region 311 of the first region 31 may be increased, and thus external light transmittance of the entire display unit 2 may be increased.

**[0034]** A gate insulating layer 213 is formed on the buffer layer 211 so as to cover the semiconductor active layer 212, and a gate electrode 214 is formed on the gate insulating layer 213.

**[0035]** An interlayer insulating layer 215 is formed on the gate insulating layer 213 so as to cover the gate electrode 214. A source electrode 216 and a drain electrode 217 are formed on the interlayer insulating layer 215 so as to contact the semiconductor active layer 212 via contact holes.

**[0036]** The structure of the thin film transistor TR is not limited to the above-described structure, and the thin film transistor TR may have various other structures.

**[0037]** A passivation layer 218 is formed to cover the thin film transistor TR. The passivation layer 218 may be a single-layered or multi-layered insulating layer, an upper surface of which is planarized. The passivation layer 218 may be formed of an inorganic material and/or an organic material.

**[0038]** As illustrated in FIG. 4, a first electrode 221 of an organic light emitting diode EL electrically connected to the thin film transistor TR is formed on the passivation layer 218. The first electrode 221 corresponds to each pixel.

**[0039]** An insulating layer 219 is formed of an organic and/or inorganic insulating material on the passivation layer 218 to cover at least an edge portion of the first electrode 221.

**[0040]** The insulating layer 219 exposes only a central portion of the first electrode 221. Although the insulating layer 219 may be included to cover the first region 31, the first insulating layer 219 does not necessarily cover the entire first region 31, and it is sufficient for the insulating layer 219 to cover only a part of the first region 31, particularly, an edge of the first electrode 221.

**[0041]** An organic layer 223 and a second electrode 222 are sequentially stacked on the first electrode 221. The second electrode 222 covers the organic layer 223 and the insulating layer 219, and second electrodes 222 corresponding to all of the pixels are electrically connected to one another.

**[0042]** The organic layer 223 may be a low molecular weight organic layer or a polymer organic layer. When the organic layer 223 is a low molecular weight organic layer, the organic layer 223 may be formed by stacking a hole injection layer (HIL), a hole transport layer (HTL), an emission layer (EML), an electron transport layer (ETL), and an electron injection layer (EIL) in a single structure or a composite structure, and may be formed of any of various materials such as copper phthalocyanine (CuPc), N,N'-Di(naphthalene-1-yl)-N,N'-diphenylbenzidine (NPB), or tris-8-hydroxyquinoline aluminum (Alq3). The low-molecular weight organic layer may be formed by vacuum deposition. Herein, the HIL, the HTL,

the ETL, and the EIL are common layers and may be commonly applied to red, green, and blue pixels.

**[0043]** The first electrode 221 may function as an anode, and the second electrode 222 may function as a cathode. Alternatively, the first electrode 221 may function as a cathode, and the second electrode 222 may function as an anode.

**[0044]** According to an embodiment of the present invention, the first electrode 221 may be a transparent electrode, and the second electrode 222 may be a reflection electrode. The first electrode 221 may include ITO, IZO, ZnO, In<sub>2</sub>O<sub>3</sub>, or the like each having a high work function. The second electrode 222 may be formed of a metal having a low work function, such as Ag, Mg, Al, Pt, Pd, Au, Ni, Nd, Ir, Cr, Li, or Ca. Accordingly, the organic light emitting diode EL is a bottom emission type in which light is emitted towards the first electrode 221.

**[0045]** However, the aspects of the present invention are not limited thereto, and the second electrode 222 may also be a transparent type electrode.

**[0046]** The passivation layer 218, the gate insulating layer 213, the interlayer insulating layer 215, and the insulating layer 219 may be transparent insulating layers.

**[0047]** A sealing substrate 4 may be installed over the second electrode 222. The sealing substrate 4 is located outside the display unit 2 and bonded with the substrate 1 by a sealant (not shown) so as to protect the second electrode 222 from external air. A filler (not shown) may be filled between the sealing substrate 4 and the second electrode 222, and a moisture absorbent may also be interposed therebetween. A sealing structure for the display unit 2 is not limited to the use of the sealing substrate 4, and a film-shaped sealing structure may be used.

**[0048]** Transmission windows 224 are further formed in the second electrode 222 and the insulating layer 219. The transmission windows 224 may be formed only in the second electrode 222, or may be formed in at least one selected from the group consisting of the passivation layer 218, the interlayer insulating layer 215, the gate insulating layer 213, and the buffer layer 211.

**[0049]** The transmission windows 224 are formed at locations corresponding to the second regions 32. The transmission windows 224 may be formed in any pattern such as the one shown in FIGS. 2 and 3. However, it is understood that the transmission windows can have a different pattern than those illustrated in FIGS. 2 and 3.

**[0050]** However, it is difficult to form the transmission windows 224 in the second electrode 222, because a metal for the second electrode 222 should be deposited using a mask having a shield portion corresponding to the pattern of the transmission windows 224 in order to form the transmission windows 224 in the pattern and manufacturing the mask having the shield portion corresponding to the pattern is very difficult.

**[0051]** A mask 5 illustrated in FIG. 5 is used to form the second electrode 222 having the transmission windows 224 arranged in such pattern.

**[0052]** The mask 5 has an aperture 51 corresponding

to a first region 31 of a specific pixel. A pattern of the apertures 51 shown in FIG. 5 is used to form the transmission windows 224 having the pattern illustrated in FIG. 3. The mask 5 has an aperture 51 corresponding to the first regions 31 of three adjacent pixels, namely, a red pixel, a green pixel, and a blue pixel. The size of the aperture 51 is generally slightly greater than the overall size of the three pixels so that patterns obtained when a material used to form the second electrode 222 is deposited via the apertures 51 overlap each other. Thus, the second electrode 222 may act as a common electrode.

**[0053]** When the three pixels constitute a unit pixel, the apertures 51 are separated from one another by a distance corresponding to the unit pixel in a horizontal direction and a vertical direction.

**[0054]** When a metal used to form the second electrode 222 is deposited on the organic layer 223 by using the mask 5, a pattern illustrated in FIG. 6A is obtained.

**[0055]** When the mask 5 is shifted by one unit pixel horizontally and then metal is deposited, a pattern as illustrated in FIG. 6B is obtained. When the mask 5 is shifted again by one unit pixel downward and then metal is deposited, a pattern as illustrated in FIG. 6C is obtained. Thereafter, when the mask 5 is shifted again by one unit pixel horizontally and then metal is deposited, a pattern as illustrated in FIG. 6D is obtained. Thus, as illustrated in FIG. 6D, the second electrode 222 having the transmission windows 224 in the pattern of FIG. 3 is obtained.

**[0056]** The pattern of the apertures 51 of the mask 5 is not limited to the pattern illustrated in FIG. 5. In other words, if an aperture 51 is formed at the center of the four adjacent apertures 51 illustrated in FIG. 5 and the aperture 51 at the center is the same as each of the four adjacent apertures 51, the second electrode 222 having the pattern illustrated in FIG. 6D may be obtained by shifting the mask 5 horizontally only once.

**[0057]** FIGS. 7 and 8 illustrate masks 5 having other shapes than the mask 5 of FIG. 5.

**[0058]** An aperture 51 corresponding to a first region 31 corresponding to three pixels is formed around a region corresponding to a transmission window 224. The pattern of the apertures 51 illustrated in FIG. 7 may allow the second electrode 222 having the pattern illustrated in FIG. 6D to be obtained by shifting the mask 5 horizontally only once. In this case, since an interval between apertures 51 is sufficient, the mask 5 is not destroyed by a tensile force but may be stable.

**[0059]** FIG. 8 illustrates a modified example of FIG. 7. A center of an aperture 51 protrudes upward and downward, and thus when a mask 5 of FIG. 7 is shifted horizontally by one unit pixel and deposition is performed, deposition occurs redundantly on the upward and downward protrusions of the aperture 51. Thus, the second electrode 222 may be stably formed through the entire display unit without any discontinuity.

**[0060]** The above embodiment applies not only to a structure in which a circuit part including the thin film transistor TR is not overlapped by the first electrode 221 as

illustrated in FIG. 4 but also to a structure in which a circuit part including the thin film transistor TR is overlapped by the first electrode 221 as illustrated in FIG. 9.

**[0061]** In the case of the structure illustrated in FIG. 9, when the first electrode 221 is formed as a reflection electrode, an effect where a conductive pattern of a circuit part is shielded by the first electrode 221 may be obtained. Thus, distortion of a penetrated image due to external light scattered by the conductive pattern of the circuit part may be suppressed.

**[0062]** Although a few embodiments of the present invention have been shown and described, it would be appreciated by those skilled in the art that changes may be made in this embodiment without departing from the principles of the invention, the scope of which is defined in the claims and their equivalents.

## Claims

1. An organic light emitting display device comprising:

- a substrate;
- a plurality of pixels formed on the substrate, each pixel comprising a first region that emits light and a second region that transmits external light;
- a respective thin film transistor disposed in the first region of each pixel;
- a respective first electrode disposed in the first region of each pixel and electrically connected to the said thin film transistor disposed in that pixel;
- a second electrode formed opposite to the plurality of first electrodes and comprising a plurality of transmission windows, wherein each of the transmission windows corresponds in position to a respective one of the second regions; and
- an organic layer formed between the first electrodes and the second electrode.

2. An organic light emitting display device according to claim 1, wherein the transmission windows for at least two adjacent pixels are separated from one another.

3. An organic light emitting display device according to claim 1 or 2, wherein the transmission windows in at least two adjacent pixels are connected to each other.

4. An organic light emitting display device according to any preceding claim, wherein the second electrode comprises a light-reflection material.

5. An organic light emitting display device according to any preceding claim, wherein the plurality of first

electrodes comprise a light-transmission material.

6. An organic light emitting display device according to any preceding claim, wherein the plurality of first electrodes overlap the plurality of thin film transistors. 5
7. An organic light emitting display device according to any preceding claim, wherein the first region of each pixel comprises an emission region and a circuit region, each thin film transistor is disposed in a respective said circuit region, and each first electrode is disposed in a respective said emission region. 10
8. An organic light emitting display device according to claim 7, wherein the emission region and the circuit region of each pixel are adjacent to each other. 15
9. An organic light emitting display device according to any preceding claim, wherein the first region of each pixel is adapted to display an image, and the second region of each pixel is adapted to transmit light. 20
10. An organic light emitting display device according to any preceding claim, wherein the second region of each pixel does not include a thin film transistor, a capacitor and an organic light emitting device. 25
11. A method of manufacturing an organic light emitting display device, the method comprising: 30
  - defining a plurality of pixels on a substrate, each of the pixels comprising a first region that emits light and a second region that transmits external light; 35
  - forming a respective thin film transistor in the first region of each pixel;
  - forming a respective first electrode in the first region of each pixel, the said first electrode being electrically connected to the thin film transistor located in that pixel; 40
  - forming an organic layer on the plurality of first electrodes; and
  - forming a second electrode on the organic layer by using a mask having a pattern of apertures corresponding to the first regions, wherein the second electrode comprises a plurality of transmission windows that correspond in position to the location of the second regions. 45
12. A method according to claim 11, wherein the apertures are separated from each other at regular intervals. 50
13. A method according to claim 12, wherein the apertures are separated from each other at intervals smaller than or equal to a distance corresponding to at least one pixel. 55

FIG. 1

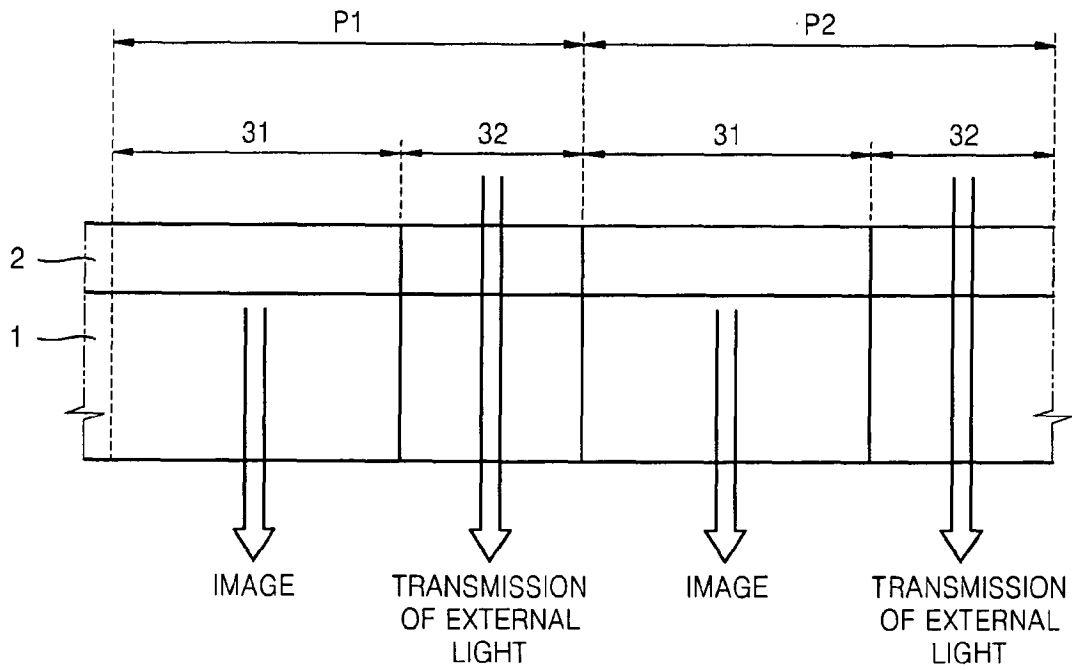

FIG. 2

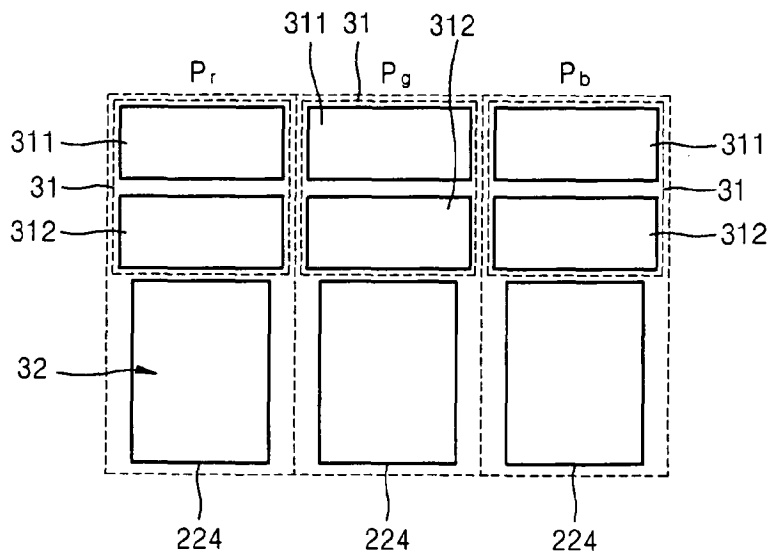



FIG. 5

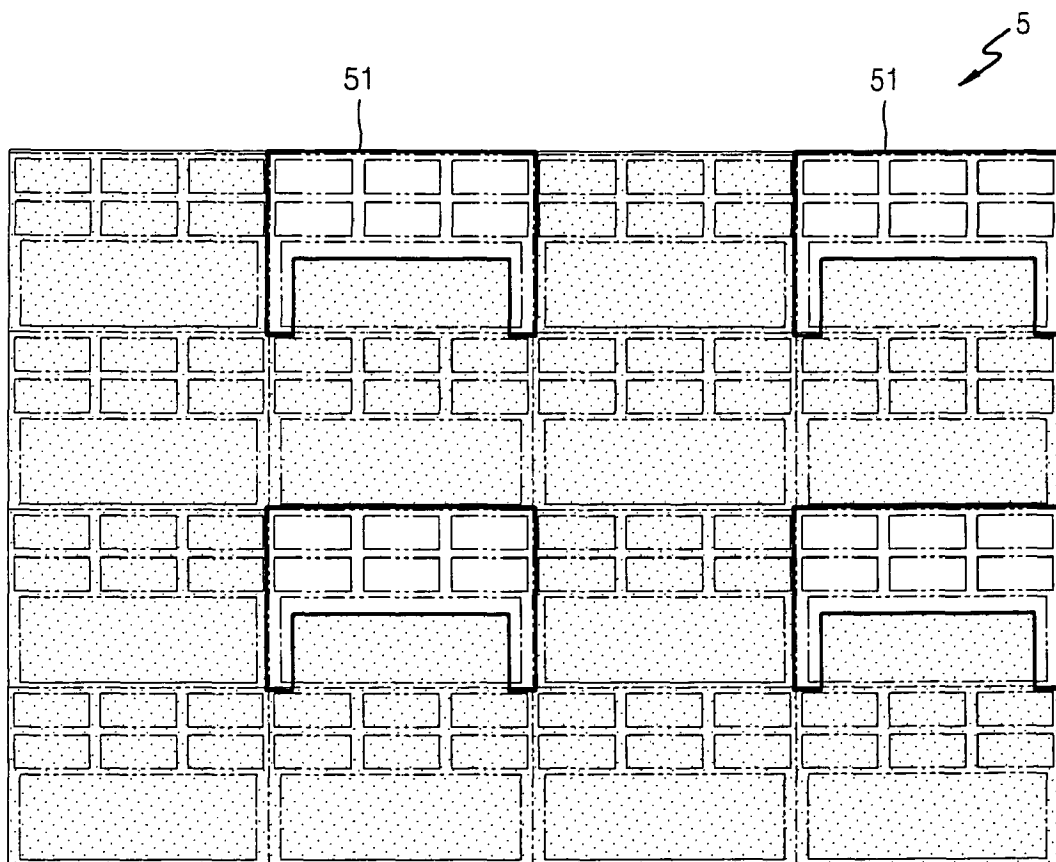

FIG. 6A

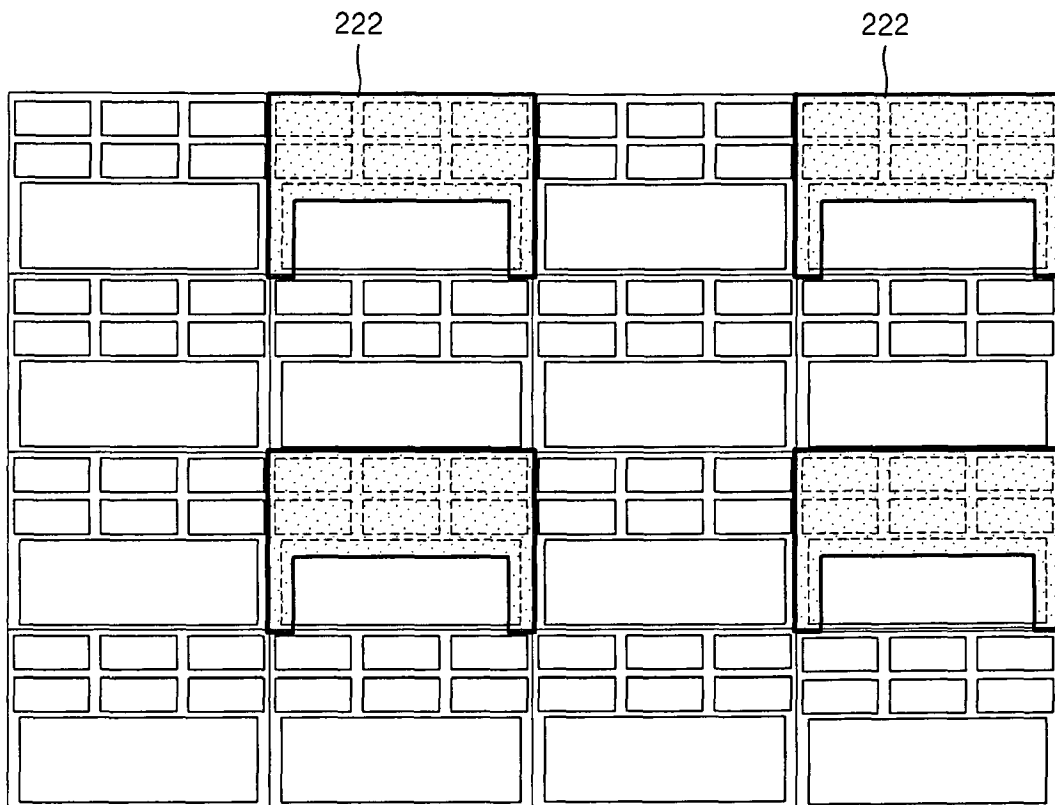

FIG. 6B

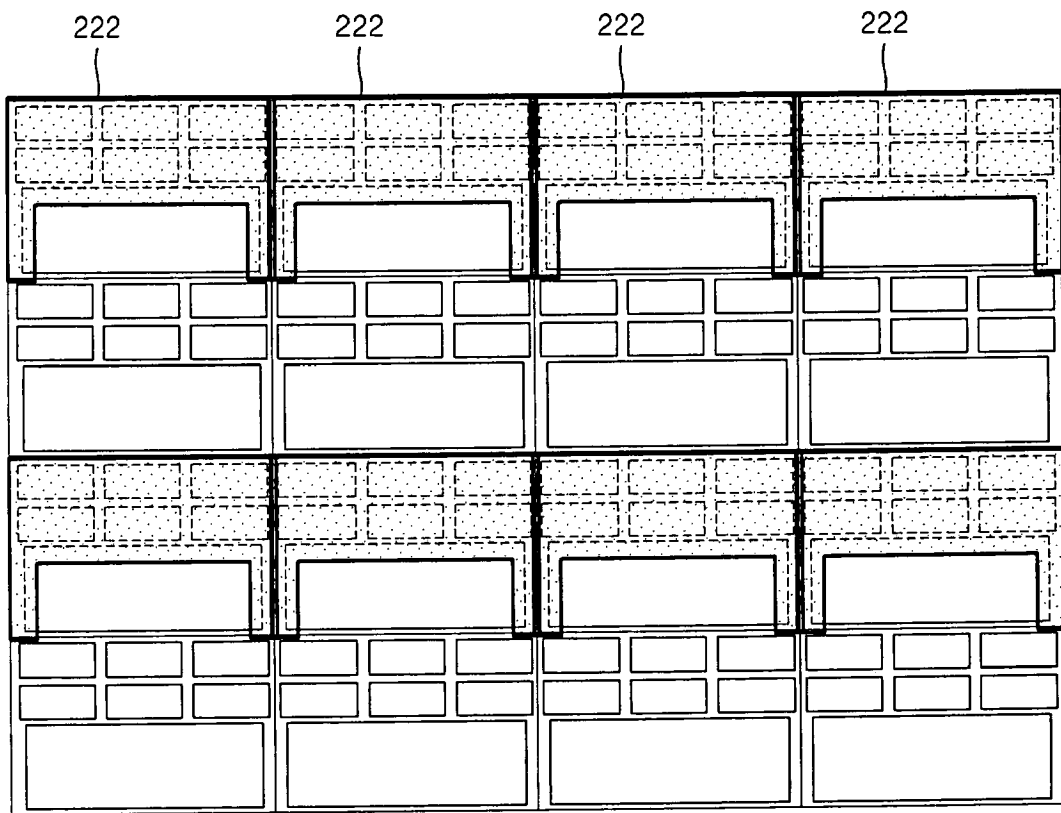

FIG. 6C

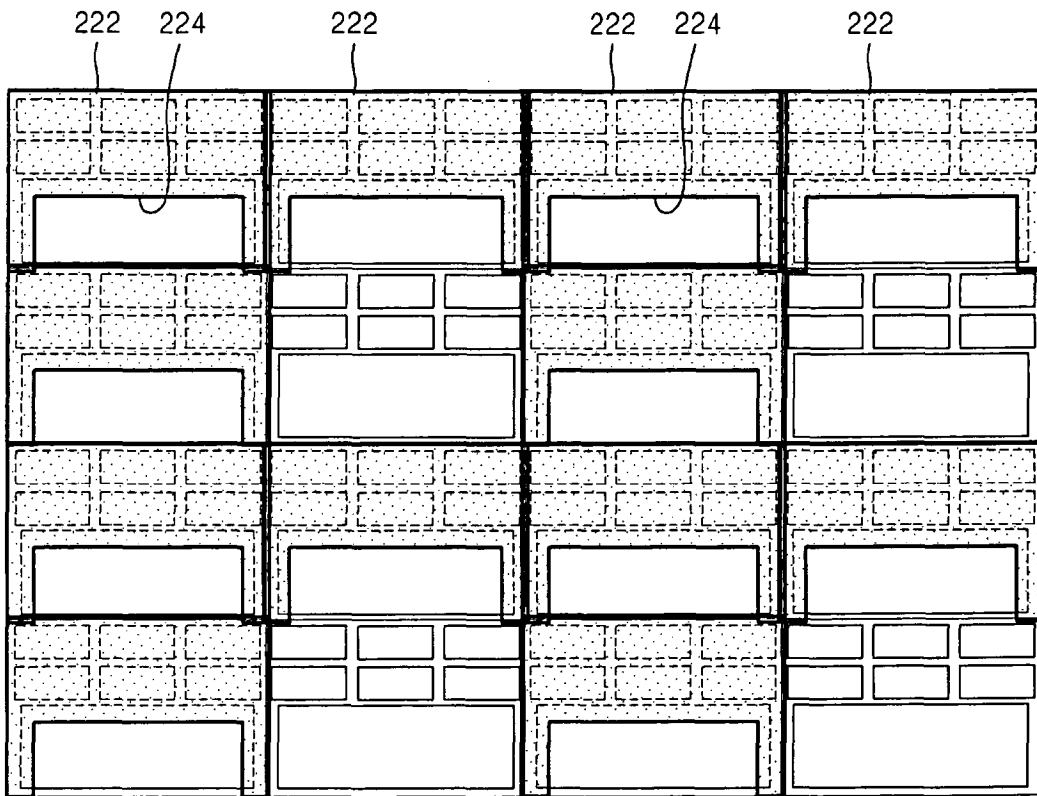

FIG. 6D

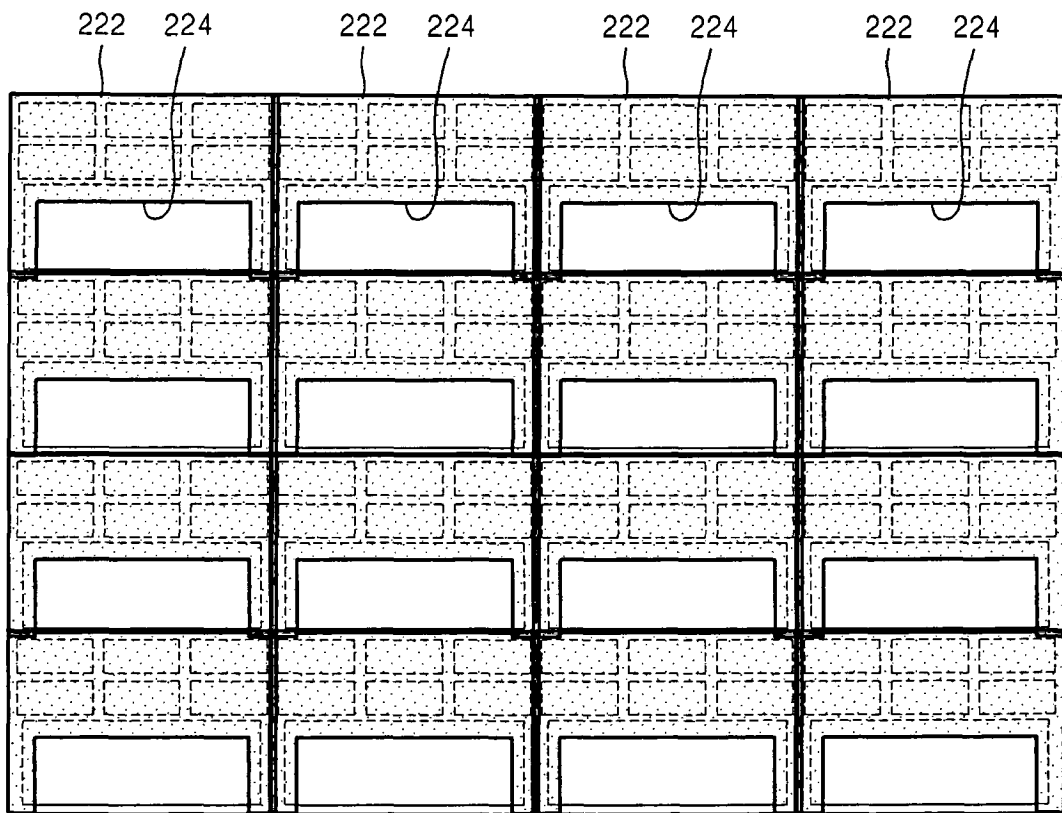

FIG. 7

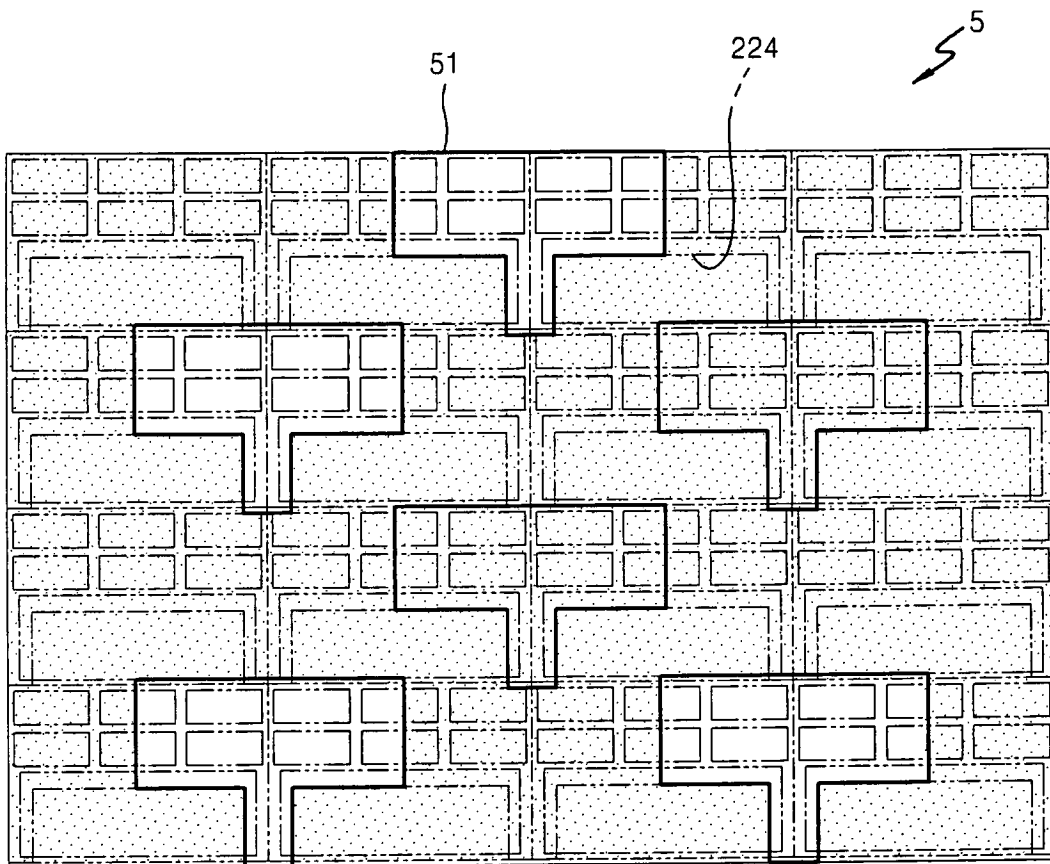

FIG. 8

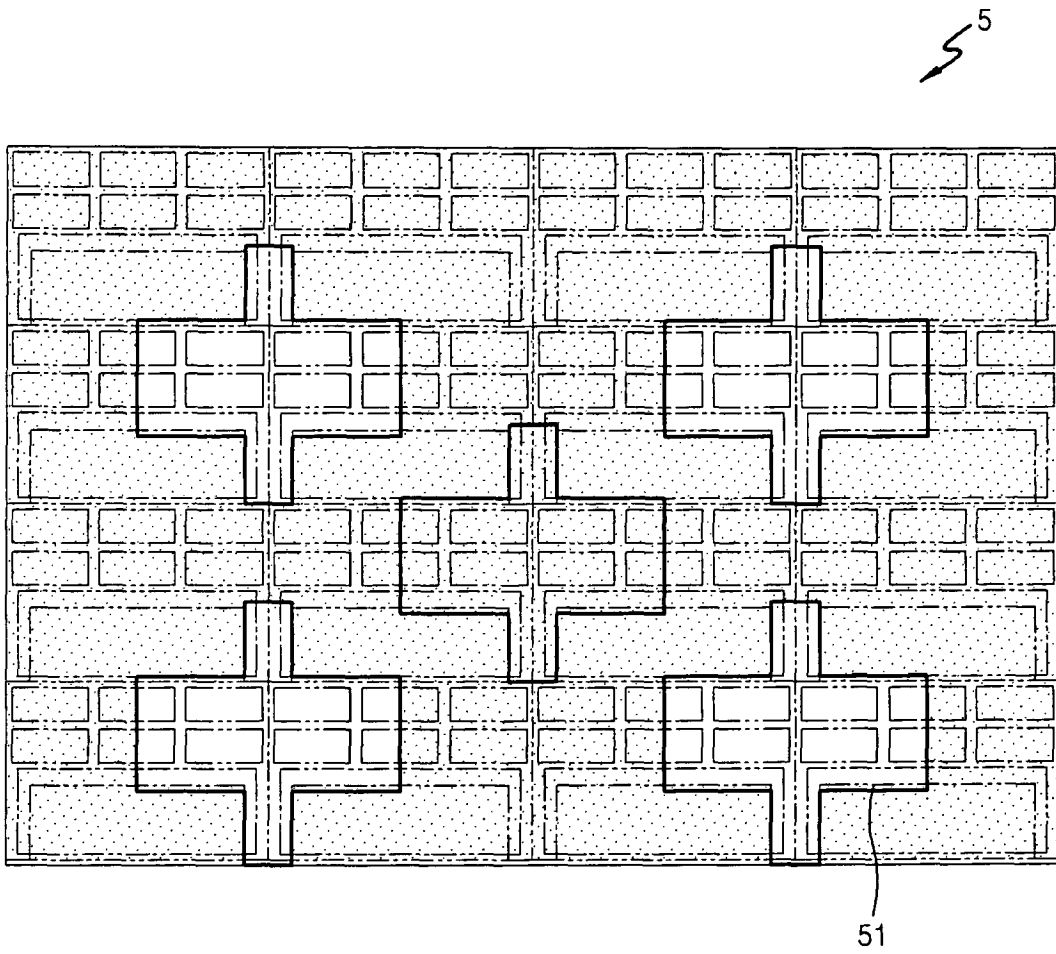
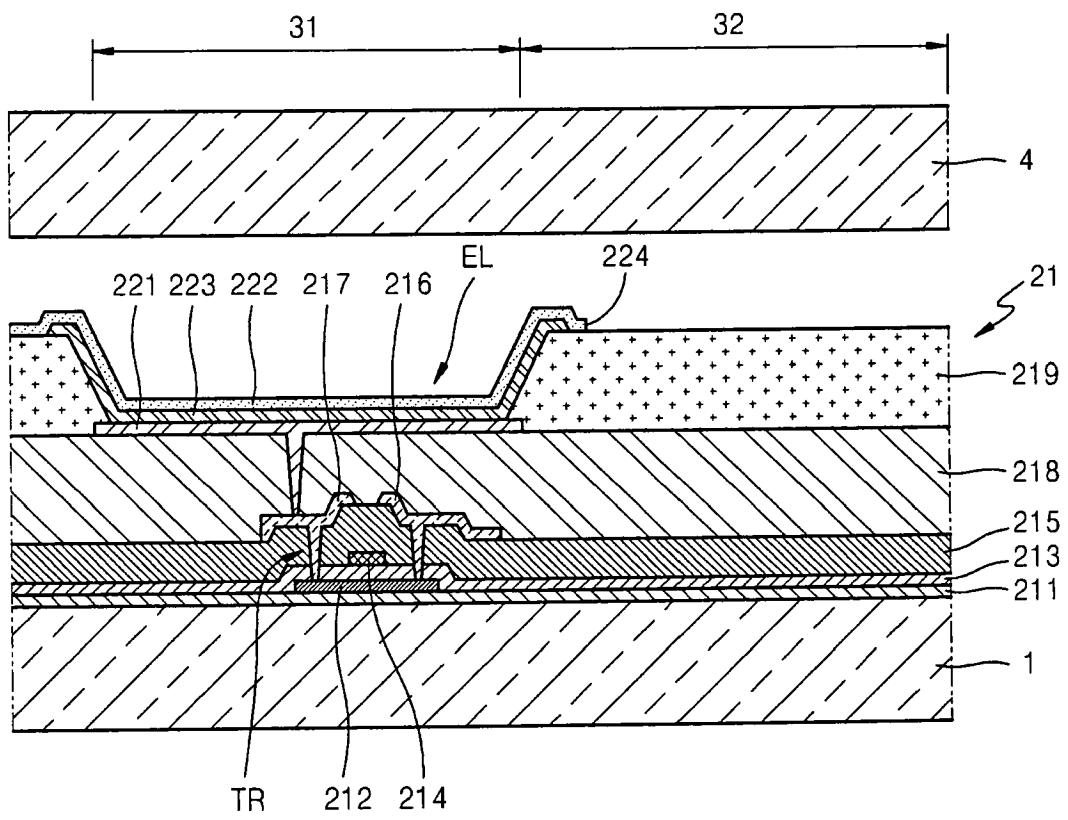

FIG. 9



专利名称(译)	有机发光显示装置及其制造方法		
公开(公告)号	<a href="#">EP2365557A2</a>	公开(公告)日	2011-09-14
申请号	EP2011250277	申请日	2011-03-10
[标]申请(专利权)人(译)	三星显示有限公司		
申请(专利权)人(译)	三星移动显示器有限公司.		
当前申请(专利权)人(译)	三星DISPLAY CO. , LTD.		
[标]发明人	PARK BYOUNG HEE LEE JOO HYEON CHUNG JIN KOO		
发明人	PARK, BYOUNG -HEE LEE, JOO-HYEON CHUNG, JIN-KOO		
IPC分类号	H01L51/52 H01L27/32		
CPC分类号	H01L51/0023 H01L27/3211 H01L27/326 H01L27/3272 H01L29/7869 H01L51/5221 H01L51/5231 H01L51/5234 H01L2227/323 H01L2251/5323		
优先权	1020100021384 2010-03-10 KR		
其他公开文献	EP2365557A3		
外部链接	<a href="#">Espacenet</a>		

摘要(译)

一种相对于外部光具有高透射率的有机发光显示装置及其制造方法。有机发光显示装置包括基板;形成在基板上的多个像素,每个像素包括发光的第一区域和透射外部光的第二区域;多个薄膜晶体管设置在每个像素的第一区域中;多个第一电极,分别设置在每个像素的第一区域中并电连接到薄膜晶体管;第二电极,与所述多个第一电极相对形成,并包括多个对应于所述第二区域的透射窗;以及在第一电极和第二电极之间形成的有机层。透射窗口可以形成在第二电极中,即阴极。

