



(12) **EUROPEAN PATENT APPLICATION**

(43) Date of publication:
07.02.2007 Bulletin 2007/06

(51) Int Cl.:
G09G 3/32^(2006.01)

(21) Application number: **06254022.4**

(22) Date of filing: **01.08.2006**

(84) Designated Contracting States:
AT BE BG CH CY CZ DE DK EE ES FI FR GB GR HU IE IS IT LI LT LU LV MC NL PL PT RO SE SI SK TR
 Designated Extension States:
AL BA HR MK YU

(72) Inventors:
 • **Chung, Bo Yong**
Samsung SDI Co. Ltd.
Yongin-si
Gyeonggi-do (KR)
 • **Ryu, Do Hyung**
Samsung SDI Co. Ltd.
Yongin-si
Gyeonggi-do (KR)
 • **Kwon, Oh Kyong**
Samsung SDI Co. Ltd.
Yongin-si
Gyeonggi-do (KR)

(30) Priority: **01.08.2005 KR 20050070439**

(71) Applicants:
 • **Samsung SDI Co., Ltd.**
Suwon-si,
Gyeonggi-do (KR)
 • **IUCF-HYU (INDUSTRY-UNIVERSITY COOPERATION FOUNDATION HANYANG UNIVERSITY)**
Seoul 133-791 (KR)

(74) Representative: **Mouteney, Simon James**
Marks & Clerk
90 Long Acre
London WC2E 9RA (GB)

(54) **Data driving circuits and organic light emitting diode display using the same**

(57) A data driving circuit for driving pixels of a display to display images with uniform brightness may include a gamma voltage unit that generates gray scale voltages, a digital-analog converter that selects, as a data signal, one of the gray scale voltages using first data, a decoder that generates second data using the first data, a latch for storing the first data and the second data, a current sink that receives a predetermined current from the pixel during a first partial period of a complete period for driving the pixel based on the selected gray scale voltage, a voltage controller that controls a voltage value of the data signal using the second data and a compensation voltage generated based on the predetermined current, and a switching unit that supplies the data signal to the pixel during any partial period of the complete period elapsing after the first partial period.

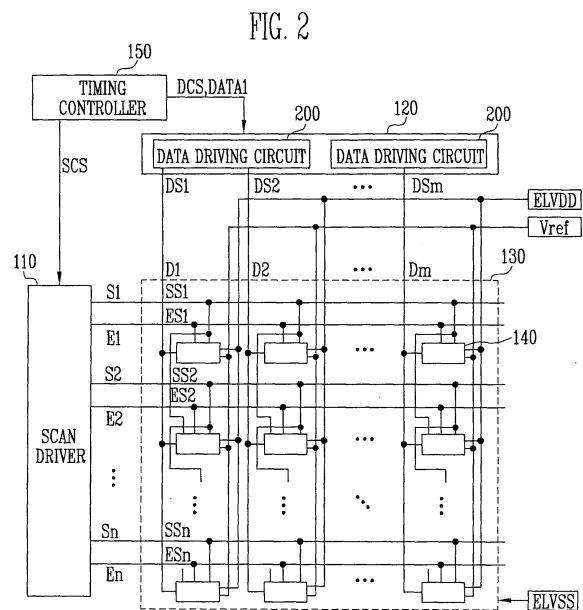

Description**BACKGROUND OF THE INVENTION**5 **1. Field of the Invention**

[0001] The present invention relates to data driving circuits, light emitting displays employing such data driving circuits and methods of driving the light emitting display. More particularly, the invention relates to a data driving circuit capable of displaying images with uniform brightness, a light emitting display using such a data driving circuit and a method of driving the light emitting display to display images with uniform brightness.

10 **2. Description of Related Art**

[0002] Flat panel displays (FPDs), which are generally lighter and more compact than cathode ray tubes (CRTs), are being developed. FPDs include liquid crystal displays (LCDs), field emission displays (FEDs), plasma display panels (PDPs) and light emitting displays.

[0003] Light emitting displays may display images using organic light emitting diodes (OLEDs) that generate light when electrons and holes recombine. Light emitting displays generally have fast response times and consume relatively low amounts of power.

20 [0004] FIG. 1 illustrates a schematic of the structure of a known light emitting display.

[0005] As shown in FIG. 1, the light emitting display may include a pixel unit 30, a scan driver 10, a data driver 20 and a timing controller 50. The pixel unit 30 may include a plurality of pixels 40 connected to scan lines S1 to Sn and data lines D1 to Dm. The scan driver 10 may drive the scan lines S1 to Sn. The data driver 20 may drive the data lines D1 to Dm. The timing controller 50 may control the scan driver 10 and the data driver 20.

25 [0006] The timing controller 50 may generate data driving control signals DCS and scan driving control signals SCS based on externally supplied synchronizing signals (not shown). The data driving control signals DCS may be supplied to the data driver 20 and the scan driving control signals SCS may be supplied to the scan driver 10. The timing controller 50 may supply data DATA to the data driver 20 in accordance with externally supplied data (not shown).

[0007] The scan driver 10 may receive the scan driving control signals SCS from the timing controller 50. The scan driver 10 may generate scan signals (not shown) based on the received scan driving control signals SCS. The generated scan signals may be sequentially supplied to the pixel unit 30 via the scan lines S1 to Sn.

30 [0008] The data driver 20 may receive the data driving control signals DCS from the timing controller 50. The data driver 20 may generate data signals (not shown) based on the received data DATA and data driving control signals DCS. Corresponding ones of the generated data signals may be supplied to the data lines D1 to Dm in synchronization with respective ones of the scan signals being supplied to the scan lines S1 to Sn.

35 [0009] The pixel unit 30 may be connected to a first power source. ELVDD for supplying a first voltage VDD and a second power source ELVSS for supplying a second voltage VSS to the pixels 40. The pixels 40, together with the first voltage VDD signal and the second voltage VSS signal, may control the currents that flow through respective OLEDs in accordance with the corresponding data signals. The pixels 40 may thereby generate light based on the first voltage VDD signal, the second voltage VSS signal and the data signals.

40 [0010] In known light emitting displays, each of the pixels 40 may include a pixel circuit including at least one transistor for selectively supplying the respective data signal and the respective scan signal for selectively turning on and turning off the respective pixel 40 of the light emitting display.

45 [0011] Each pixel 40 of a light emitting display can generate light of predetermined brightness in response to various values of the respective data signals. For example, when the same data signal is applied to all the pixels 40 of the display, it is generally desired for all the pixels 40 of the display to generate the same brightness. The brightness generated by each pixel 40 is not, however, only dependent on the data signal, but is also dependent on characteristics of each pixel 40, e.g., threshold voltage of each transistor of the pixel circuit.

50 [0012] Generally, there are variations in threshold voltage and/or electron mobility from transistor to transistor such that different transistors have different threshold voltages and electron mobilities. The characteristics of transistors may also change over time and/or usage. For example, the threshold voltage and electron mobility of a transistor may be dependent on the on/off history of the transistor.

55 [0013] Therefore, in a light emitting display, the brightness generated by each pixel in response to respective data signals depends on the characteristics of the transistor(s) that may be included in the respective pixel circuit. Such variations in threshold voltage and electron mobility may prevent and/or hinder the uniformity of images being displayed. Thus, such variations in threshold voltage and electron mobility may also prevent the display of an image with a desired brightness.

[0014] Although it may be possible to at least partially compensate for differences between threshold voltages of the

transistors included in the pixels by controlling the structure of the pixel circuits of the pixels 40, circuits and methods capable of compensating for the variations in electron mobility are still needed. Light emitting devices, e.g., OLEDs, that are capable of displaying images with uniform brightness irrespective of variations in electron mobility are also desired.

5 SUMMARY OF THE INVENTION

[0015] The present invention is therefore directed to a data driving circuit and a light emitting display using the same, which substantially overcome one or more of the problems due to the limitations and disadvantages of the related art.

10 **[0016]** It is therefore a feature of an embodiment of the present invention to provide a data driving circuit capable of driving pixels of a light emitting display to display images with uniform brightness, a light emitting display using the same, and a method of driving the light emitting display.

15 **[0017]** According to a first aspect of the present invention there is provided a data driving circuit including a decoder for generating second data having p bits using externally supplied first data having k bits, a latch for storing the first data and the second data, a gamma voltage unit for generating a plurality of gray scale voltages, a digital-to-analog converter for selecting one gray scale voltage among the plurality of gray scale voltages as a data signal based on the first data, a current sink unit receiving a predetermined current from a pixel during a first partial period of a complete period for driving the pixel based on the selected gray scale voltage, a voltage controller for controlling a voltage value of the data signal based on a compensation voltage generated based on the predetermined current and the second data, and a switching unit for supplying the controlled data signal to the pixel during a second partial period of the one complete period, the second partial period being different from the first partial period and the second partial period elapsing after the first partial period.

20 **[0018]** The decoder may convert the first data into a binary weighted value to generate the second data. The data driving circuit may further include a first transistor disposed between the digital-analog converter and the switching unit, the digital-analog converter being turned on during a predetermined time of the first partial period to transfer the data signal, with the controlled voltage value, to the switching unit, and a first buffer connected between the first transistor and the switching unit. The gamma voltage unit may include a plurality of distribution resistors for generating the gray scale voltages and distributing a reference supply voltage and a first supply voltage, and a second buffer for supplying the first supply voltage to the voltage controller.

25 **[0019]** The voltage controller may include p capacitors, each of the capacitors having a first terminal connected to an electrical path between the first transistor and the first buffer, second transistors respectively connected between a second terminal of each of the p capacitors and the second buffer, third transistors connected respectively between the second terminals of the p capacitors and the current sink unit and having a conduction type different from a conduction type of the second transistors, fourth transistors connected between the second transistors and a predetermined voltage source and having a same conduction type as the conduction type of the second transistors, and fifth transistors having a same conduction type as the conduction type of the third transistors, the fifth transistors for supplying the second data to the second transistors.

30 **[0020]** The fourth transistors may be turned on during the first period so that the second transistors may be turned on to supply a voltage of the predetermined voltage source to gate electrodes of the second transistors. The predetermined voltage source may be a ground voltage source. The third transistors may be selectively turned on during the first partial period so that the second terminals of the capacitors are set to have the voltage of the predetermined voltage source. The fifth transistors may consist of p transistors, corresponding to the number of bits of the second data, and the fifth transistors may respectively supply different bits of the p bits of second data to the second transistors.

35 **[0021]** Each of the third transistors that receives a bit having a value of 1 may be turned on to supply the respective compensation voltage to the second terminals of the respective p capacitors. Capacitances of the p capacitors may be set to binary weighted values. The current sink unit may include a current source providing the predetermined current, a first transistor provided between a data line connected to the pixel and the voltage controller, the first transistor being turned on during the first partial period, a second transistor provided between the data line and the current source, the second transistor being turned on in the first partial period, a capacitor for charging the compensation voltage, and a buffer provided between the first transistor and the voltage controller to selectively transmit the compensation voltage to the voltage controller.

40 **[0022]** The predetermined current may be equal to a current value of a minimum current flowing through the pixel when the pixel emits light with maximum brightness, and maximum brightness may correspond to a brightness of the pixel when a highest one of the plurality of reset gray scale voltages is applied to the pixel. The switching unit may include at least one transistor that is turned on during the second partial period. The switching unit may include two transistors which are connected so as to form a transmission gate. The data driving circuit may further include a shift register unit including at least one shift register to sequentially generate sampling pulses and to supply the sampling pulses to the latch unit.

45 **[0023]** The latch unit may include a sampling latch unit including at least one sampling latch for receiving the first and

second data in response to the sampling pulses, a holding latch unit including at least one holding latch for receiving the first and second data stored in the sampling latch unit to supply the first data stored therein to the digital-to-analog converter and to supply the second data to the voltage controller.

[0024] Each of the sampling latches and the holding latches may have a magnitude of $k+p$ bits. The data driving circuit may further include a level shifter unit for increasing voltage levels of the first data and the second data stored in the holding latch to respectively supply the adjusted voltage levels of the stored first data and the stored second data to the digital-to-analog converter and the voltage controller.

[0025] According to a second aspect of the present invention there is provided a light emitting display including a pixel unit including a plurality of pixels connected to n scan lines, a plurality of data lines, and a plurality of emission control lines, a scan driver respectively and sequentially supplying, during each scan cycle, n scan signals to the n scan lines, and for sequentially supplying emission control signals to the plurality of emission control lines, and a data driver having at least one data driving circuit for respectively supplying data signals to the data lines, wherein the data driving circuit include a decoder for generating second data having p bits using externally supplied first data having k bits, a latch for storing the first data and the second data, a gamma voltage unit for generating a plurality of gray scale voltages, a digital-to-analog converter for selecting one gray scale voltage among the plurality of gray scale voltages as a data signal based on the first data, a current sink unit receiving a predetermined current from a pixel during a first partial period of a complete period for driving the pixel based on the selected gray scale voltage, a voltage controller for controlling a voltage value of the data signal based on a compensation voltage generated based on the predetermined current and the second data, and a switching unit for supplying the controlled data signal to the pixel during a second partial period of the one complete period, the second partial period being different from the first partial period and the second partial period elapsing after the first partial period.

[0026] Each of the pixels may be connected to two of the n scan lines, and during each of the scan cycles, a first of the two scan lines receiving a respective one of the n scan signals before a second of the two scan lines receives a respective one of the n scan signals, and each of the pixels may include a first power source, a light emitter receiving current from the first power source, first and second transistors each having a first electrode connected to the respective one of the data lines associated with the pixel, the first and second transistors being turned on when the first of the two scan signals is supplied, a third transistor having a first electrode connected to a reference power source and a second electrode connected to a second electrode of the first transistor, the third transistor being turned on when the first of the two scans signal is supplied, a fourth transistor controlling an amount of current supplied to the light emitter, a first terminal of the fourth transistor being connected to the first power source, and a fifth transistor having a first electrode connected to a gate electrode of the fourth transistor and a second electrode connected to a second electrode of the fourth transistor, the fifth transistor being turned on when the first of the two scan signals is supplied such that the fourth transistor operates as a diode.

[0027] Each of the pixels may include a first capacitor having a first electrode connected to one of a second electrode of the first transistor or the gate electrode of the fourth transistor and a second electrode connected to the first power source and a second capacitor having a first electrode connected to the second electrode of the first transistor and a second electrode connected to the gate electrode of the fourth transistor. Each of the pixels may further include a sixth transistor having a first terminal connected to the second electrode of the fourth transistor and a second terminal connected to the light emitter, the sixth transistor being turned off when the respective emission control signal is supplied, wherein the current sink may receive the predetermined current from the pixel during a first partial period of one complete period for driving the pixel, the first partial period occurring before a second partial period of the complete period for driving the pixel, and the sixth transistor may be turned on during the second partial period of the complete period for driving the pixel.

[0028] According to a third aspect of the present invention there is provided a data driving method as set out in Claim 26.

BRIEF DESCRIPTION OF THE DRAWINGS

[0029] These and other features and advantages of the invention will become apparent to those of ordinary skill in the art by describing in detail exemplary embodiments thereof with reference to the attached drawings in which:

[0030] FIG. 1 illustrates a schematic diagram of a known light emitting display;

[0031] FIG. 2 illustrates a schematic diagram of a light emitting display according to an embodiment of the present invention;

[0032] FIG. 3 illustrates a circuit diagram of an exemplary pixel employable in the light emitting display illustrated in FIG. 2;

[0033] FIG. 4 illustrates exemplary waveforms employable for driving the pixel illustrated in FIG. 3;

[0034] FIG. 5 illustrates a circuit diagram of another exemplary pixel employable in the light emitting display illustrated in FIG. 2;

[0035] FIG. 6 is a block diagram illustrating a first embodiment of the data driving circuit illustrated in FIG. 2;

[0036] FIG. 7 illustrates an embodiment of the sampling latch unit and the holding latch unit illustrated in FIG. 6;

[0037] FIG. 8 illustrates a block diagram of a second embodiment of the data driving circuit illustrated in FIG. 2;

[0038] FIG. 9 illustrates a schematic diagram of a first embodiment of a connection scheme connecting a gamma voltage unit, a digital-to-analog converter unit, a switching unit, a voltage controlling unit and a current sink unit illustrated in FIG. 6, and a pixel illustrated in FIG. 3;

[0039] FIG. 10 illustrates exemplary waveforms employable for driving the pixel, the switching unit and the current sink illustrated in FIG. 9;

[0040] FIG. 11 illustrates the connection scheme illustrated in FIG. 9 employing another embodiment of a switching unit; and

[0041] FIG. 12 illustrates a schematic diagram of a second embodiment of a connection scheme connecting a gamma voltage unit, a digital-to-analog converter unit, a switching unit, a voltage controlling unit and a current sink unit illustrated in FIG. 6, and a pixel illustrated in FIG. 5.

DETAILED DESCRIPTION OF THE INVENTION

[0042] The present invention will now be described more fully hereinafter with reference to the accompanying drawings, in which exemplary embodiments of the invention are shown. The invention may, however, be embodied in different forms and should not be construed as limited to the embodiments set forth herein. Rather, these embodiments are provided so that this disclosure will be thorough and complete, and will fully convey the scope of the invention to those skilled in the art. Like reference numerals refer to like elements throughout.

[0043] Hereinafter, exemplary embodiments of the present invention will be described with reference to FIGS. 2 to 12. In data driving circuits and light emitting displays employing one or more aspects of embodiments of the invention, because a voltage value of the data signal is reset using a compensation voltage generated when current sinks from a respective pixel, uniform images can be displayed regardless of electron mobility, threshold voltages, etc. of transistors.

[0044] FIG. 2 illustrates a schematic diagram of a light emitting display according to an embodiment of the present invention.

[0045] As shown in FIG. 2, the light emitting display may include a scan driver 110, a data driver 120, a pixel unit 130 and a timing controller 150. The pixel unit 130 may include a plurality of pixels 140. The pixel unit 130 may include $n \times m$ pixels 140 arranged, for example, in n rows and m columns, where n and m may each be integers. The pixels 140 may be connected to scan lines $S1$ to S_n , emission control lines $E1$ to E_n and data lines $D1$ to D_m . The pixels 140 may be respectively formed in the regions partitioned by the emission control lines E_{n1} to E_n and the data lines $D1$ to D_m . The scan driver 110 may drive the scan lines $S1$ to S_n and the emission control lines $E1$ to E_n . The data driver 120 may drive the data lines $D1$ to D_m . The timing controller 150 may control the scan driver 110 and the data driver 120. The data driver 120 may include one or more data driving circuits 200.

[0046] The timing controller 150 may generate data driving control signals DCS and scan driving control signals SCS in response to externally supplied synchronizing signals (not shown). The data driving control signals DCS generated by the timing controller 150 may be supplied to the data driver 120. The scan driving control signals SCS generated by the timing controller 150 may be supplied to the scan driver 110. The timing controller 150 may supply first data DATA1 to the data driver 120 in accordance with the externally supplied data (not shown).

[0047] The scan driver 110 may receive the scan driving control signals SCS from the timing controller 150. The scan driver 110 may generate scan signals $SS1$ to SS_n based on the received scan driving control signals SCS and may sequentially and respectively supply the scan signals $SS1$ to SS_n to the scan lines $S1$ to S_n . The scan driver 110 may sequentially supply emission control signals $ES1$ to ES_n to the emission control lines $E1$ to E_n . Each of the emission control signals $ES1$ to ES_n may be supplied, e.g., changed from a low voltage signal to a high voltage signal, such that an "on" emission control signal, e.g., a high voltage signal, at least partially overlaps at least two of the scan signals $SS1$ to SS_n . Therefore, in embodiments of the invention, a pulse width of the emission control signals $ES1$ to ES_n may be equal to or larger than a pulse width of the scan signals $SS1$ to SS_n .

[0048] The data driver 120 may receive the data driving control signals DCS from the timing controller 150. The data driver 120 may generate data signals $DS1$ to DS_m based on the received data driving control signals DCS and the first data DATA1. The generated data signals $DS1$ to DS_m may be supplied to the data lines $D1$ to D_m in synchronization with the scan signals $SS1$ to SS_n supplied to the scan lines $S1$ to S_n . For example, when the first scan signal $SS1$ is supplied, the generated data signals $DS1$ to DS_m corresponding to the pixels $140(1)(1$ to $m)$ may be synchronously supplied to the first to the m -th pixels in the first row via the data lines $D1$ to D_m , and when the n th scan signal SS_n is supplied, the generated data signals $DS1$ to DS_m corresponding to the pixels $140(n)(1$ to $m)$ may be synchronously supplied to the first to the m -th pixels in the n -th row via the data lines $D1$ to D_m .

[0049] The data driver 120 may supply predetermined currents to the data lines $D1$ to D_m during a first period of one horizontal period $1H$ for driving one or more of the pixels 140. For example, one horizontal period $1H$ may correspond to a complete period associated with one of the scan signals $SS1$ to SS_n and a corresponding one of the data signals $DS1$ to DS_m being supplied to the respective pixel 140 in order to drive the respective pixel 140. The data driver 120

may supply predetermined voltages to the data lines D1 to Dm during a second period of the one horizontal period 1H. For example, one horizontal period 1H may correspond to a complete period associated with one of the scan signals SS1 to SSn and a corresponding one of the data signals DS1 to DSm being supplied to the respective pixel 140 in order to drive the respective pixel 140. In embodiments of the invention, the data driver 120 may include at least one data driving circuit 200 for supplying such predetermined currents and predetermined voltages during the first and second periods of one horizontal period 1H. In the following description, the predetermined voltages that may be supplied to the data lines D1 to Dm during the second period will be referred to as the data signals DS1 to DSm.

[0050] The pixel unit 130 may be connected to a first power source ELVDD for supplying a first voltage VDD, a second power source ELVSS for supplying a second voltage VSS and a reference power source ELVref for supplying a reference voltage Vref to the pixels 140. The first power source ELVDD, the second power source ELVSS and the reference power source ELVref may be externally provided. The pixels 140 may receive the first voltage VDD signal and the second voltage VSS signal, and may control the currents that flow through respective light emitting devices/materials, e.g., OLEDs, in accordance with the data signals DS1 to DSm that may be supplied by the data driver 120 to the pixels 140. The pixels 140 may thereby generate light components corresponding to the received first data DATA1.

[0051] Some or all of the pixels 140 may receive the first voltage VDD signal, the second voltage VSS signal and the reference voltage Vref signal from the respective first, second and reference power sources ELVDD, ELVSS and ELVref. The pixels 140 may compensate for a voltage drop in the first voltage VDD signal and/or threshold voltage(s) using the reference voltage Vref signal. The amount of compensation may be based on a difference between voltage values of the reference voltage Vref signal and the first voltage VDD signal respectively supplied by the reference power source ELVref and the first power source ELVDD. The pixels 140 may supply respective currents from the first power source ELVDD to the second power source ELVSS via, e.g., the OLEDs in response to the respective data signals DS1 to DSm. In embodiments of the invention, each of the pixels 140 may have, for example, the structure illustrated in FIG. 3 or FIG. 5.

[0052] FIG. 3 illustrates a circuit diagram of an nm-th exemplary pixel 140nm employable in the light emitting display illustrated in FIG. 2. For simplicity, FIG. 3 illustrates the nm-th pixel that may be the pixel provided at the intersection of the n-th row of scan lines Sn and the m-th row of data lines Dm. The nm-th pixel 140nm may be connected to the m-th data line Dm, the n-1th and nth scan lines Sn-1 and Sn and the nth emission control line En. For simplicity, FIG. 3 only illustrates one exemplary pixel 140nm. In embodiments of the invention, the structure of the exemplary pixel 140nm may be employed for all or some of the pixels 140 of the light emitting display.

[0053] Referring to FIG. 3, the nm-th pixel 140nm may include a light emitting material/device, e.g., OLEDnm, and an nm-th pixel circuit 142nm for supplying current to the associated light emitting material/device.

[0054] The nm-th OLEDnm may generate light of a predetermined color in response to the current supplied from the nm-th pixel circuit 142nm. The nm-th OLEDnm may be formed of, e.g., organic material, phosphor material and/or inorganic material.

[0055] In embodiments of the invention, the nm-th pixel circuit 142nm may generate a compensation voltage for compensating for variations within and/or among the pixels 140 such that the pixels 140 may display images with uniform brightness. The nm-th pixel circuit 142nm may generate the compensation voltage using a previously supplied scan signal of the scan signals SS1 to SSn during each scan cycle. In embodiments of the invention, one scan cycle may correspond to scan signals SS1 to SSn being sequentially supplied. Thus, in embodiments of the invention, during each cycle, the n-1th scan signal SSn-1 may be supplied prior to the nth scan signal SSn and when the n-1th scan signal SSn-1 is being supplied to the n-1th scan line of the light emitting display, the nm-th pixel circuit 142nm may employ the n-1th scan signal SSn-1 to generate a compensation voltage. For example, the second pixel in the second column, i.e., the pixel 140₂₂, may generate a compensation voltage using the first scan signal SS1.

[0056] The compensation voltage may compensate for a voltage drop in a source voltage signal and/or a voltage drop resulting from a threshold voltage of the transistor of the nm-th pixel circuit 142nm. For example, the nm-th pixel circuit 142nm may compensate for a voltage drop of the first voltage VDD signal and/or a threshold voltage of a transistor, e.g., a threshold voltage of a fourth transistor M4nm of the pixel circuit 142nm based on the compensation voltage that may be generated using a previously supplied scan line during the same scan cycle.

[0057] In embodiments of the invention, the pixel circuit 142nm may compensate for a drop in the voltage of the first power source ELVDD and the threshold voltage of the fourth transistor M4nm when the n-1th scan signal SSn-1 is supplied to the n-1th scan line Sn-1, and may charge the voltage corresponding to the data signal DSm when the nth scan signal SSn is supplied to the nth scan line Sn. In embodiments of the invention, the pixel circuit 142nm may include first to sixth transistors M1nm to M6nm, a first capacitor C1nm and a second capacitor C2nm to generate the compensation voltage and to drive the light emitting material/device.

[0058] A first electrode of the first transistor M1nm may be connected to the data line Dm and a second electrode of the first transistor M1nm may be connected to a first node N1nm. A gate electrode of the first transistor M1nm may be connected to the nth scan line Sn. The first transistor M1nm may be turned on when the nth scan signal SSn is supplied to the nth scan line Sn. When the first transistor M1nm is turned on, the data line Dm may be electrically connected to the first node N1nm.

[0059] A first electrode of the first capacitor C1nm may be connected to the first node N1nm and a second electrode of the first capacitor C1nm may be connected to the first power source ELVDD.

[0060] A first electrode of the second transistor M2nm may be connected to the data line Dm and a second electrode of the second transistor M2nm may be connected to a second electrode of the fourth transistor M4nm. A gate electrode of a second transistor M2nm may be connected to the nth scan line Sn. The second transistor M2nm may be turned on when the nth scan signal SSn is supplied to the nth scan line Sn. When the second transistor M2nm is turned on, the data line Dm may be electrically connected to the second electrode of the fourth transistor M4nm.

[0061] A first electrode of the third transistor M3nm may be connected to the reference power source ELVref and a second electrode of the third transistor M3nm may be connected to the first node N1nm. A gate electrode of the third transistor M3nm may be connected to the n-1th scan line Sn-1. The third transistor M3nm may be turned on when the n-1th scan signal SSn-1 is supplied to the n-1th scan line Sn-1. When the third transistor M3nm is turned on, the reference voltage Vref may be electrically connected to the first node N1nm.

[0062] A first electrode of the fourth transistor M4nm may be connected to the first power source ELVDD and the second electrode of the fourth transistor M4nm may be connected to a first electrode of the sixth transistor M6nm. A gate electrode of the fourth transistor M4nm may be connected to the second node N2nm.

[0063] A first electrode of the second capacitor C2nm may be connected to the first node N1nm and a second electrode of the second capacitor C2nm may be connected to the second node N2nm.

[0064] In embodiments of the invention, the first and second capacitors C1nm and C2nm may be charged when the n-1th scan signal SSn-1 is supplied. In particular, the first and second capacitors C1nm and C2nm may be charged and the fourth transistor M4nm may supply a current corresponding to a voltage at the second node N2nm to the first electrode of the sixth transistor M6nm.

[0065] A second electrode of the fifth transistor M5nm may be connected to the second node N2nm and a first electrode of the fifth transistor M5nm may be connected to the second electrode of the fourth transistor M4nm. A gate electrode of the fifth transistor M5nm may be connected to the n-1th scan line Sn-1. The fifth transistor M5nm may be turned on when the n-1th scan signal SSn-1 is supplied to the n-1th scan line Sn-1 so that current flows through the fourth transistor M4nm. Therefore, the fourth transistor M4nm may operate as a diode.

[0066] The first electrode of the sixth transistor M6nm may be connected to the second electrode of the fourth transistor M4nm and a second electrode of the sixth transistor M6nm may be connected to an anode electrode of the nm-th OLEDnm. A gate electrode of the sixth transistor M6nm may be connected to the nth emission control line En. The sixth transistor M6nm may be turned off when an emission control signal ESn, e.g., a high voltage signal, is supplied to the nth emission control line En and may be turned on when no emission control signal, e.g., a low voltage signal, is supplied to the nth emission control line En.

[0067] In embodiments of the invention, the emission control signal ESn supplied to the nth emission control line En may be supplied to at least partially overlap both the n-1th scan signal SSn-1 that may be supplied to the n-1th scan line Sn-1 and the nth scan signal SSn that may be supplied to nth scan line Sn. Therefore, the sixth transistor M6nm may be turned off when the n-1th scan signal SSn-1, e.g., a low voltage signal, is supplied to the n-1th scan line Sn-1 and the n-th scan signal SSn, e.g., a low voltage signal, is supplied to the nth scan line Sn so that a predetermined voltage may be charged in the first and second capacitors C1nm and C2nm. The sixth transistor M6nm may be turned on during other times to electrically connect the fourth transistor M4nm and the nm-th OLEDnm to each other. In the exemplary embodiment shown in FIG. 3, the transistors M1nm to M6nm are PMOS transistors, which may turn on when a low voltage signal is supplied to the respective gate electrode and may turn on when a high voltage signal is supplied to the respective gate electrode. However, embodiments of the present invention are not limited to PMOS devices.

[0068] In the pixel illustrated in FIG. 3, because the reference power source EL Vref does not supply current to the pixels 140, a drop in the voltage of the reference voltage Vref may not occur. Therefore, it is possible to maintain the voltage value of the reference voltage Vref signal uniform regardless of the positions of the pixels 140. In embodiments of the invention, the voltage value of the reference voltage Vref may be equal to or different from the first voltage ELVDD.

[0069] FIG. 4 illustrates exemplary waveforms that may be employed for driving the exemplary nm-th pixel 140nm illustrated in FIG. 3. As shown in FIG. 4, each horizontal period 1H for driving the nm-th pixel 140nm may be divided into a first period and a second period. During the first period, predetermined currents (PCs) may respectively flow through the data lines D1 to Dm. During the second period, the data signals DS1 to DSm may be supplied to the respective pixels 140 via the data lines D1 to Dm. During the first period, the respective PCs may be supplied from each of the pixel(s) 140 to a data driving circuit 200 that may be capable of functioning, at least in part, as a current sink. During the second period, the data signals DS1 to DSm may be supplied from the data driving circuit 200 to the pixel(s) 140. For simplicity, in the following description, it will be assumed that, at least initially, i.e., prior to any voltage drop that may result during operation of the pixels 140, the voltage value of the reference voltage Vref signal is equal to the voltage value of the first voltage VDD signal.

[0070] Exemplary methods of operating the nm-th pixel circuit 142nm of the nm-th pixel 140nm of the pixels 140 will be described in detail with reference to FIGS. 3 and 4. First, the n-1th scan signal SSn-1 may be supplied to the n-1th

scan line S_{n-1} to control the on/off operation of the m pixels that may be connected to the $n-1$ th scan line S_{n-1} . When the scan signal SS_{n-1} is supplied to the $n-1$ th scan line S_{n-1} , the third and fifth transistors M_{3nm} and M_{5nm} of the nm -th pixel circuit 142nm of the nm pixel 140nm may be turned on. When the fifth transistor M_{5nm} is turned on, current may flow through the fourth transistor M_{4nm} so that the fourth transistor M_{4nm} may operate as a diode. When the fourth transistor M_{4nm} operates as a diode, the voltage value of the second node N_{2nm} may correspond to a difference between the threshold voltage of the fourth transistor M_{4nm} and the voltage of the first voltage VDD signal being supplied by the first power source $ELVDD$.

[0071] More particularly, when the third transistor M_{3nm} is turned on, the reference voltage V_{ref} signal from the reference power source ELV_{ref} may be applied to the first node N_{1nm} . The second capacitor C_{2nm} may be charged with a voltage corresponding to the difference between the first node N_{1nm} and the second node N_{2nm} . In embodiments of the invention in which the reference voltage V_{ref} signal from the reference power source ELV_{ref} and the first voltage VDD from the first power source $ELVDD$ may, at least initially, i.e., prior to any voltage drop that may result during operation of the pixels 140, be equal, the voltage corresponding to the threshold voltage of the fourth transistor M_{4nm} may be charged in the second capacitor C_{2nm} . In embodiments of the invention in which a predetermined drop in voltage of the first voltage VDD signal occurs, the threshold voltage of the fourth transistor M_{4nm} and a voltage corresponding to the magnitude of the voltage drop of the first power source $ELVDD$ may be charged in the second capacitor C_{2nm} .

[0072] In embodiments of the invention, during the period where the $n-1$ th scan signal SS_{n-1} may be supplied to the $n-1$ th scan line S_{n-1} , a predetermined voltage corresponding to the sum of the voltage corresponding to the voltage drop of the first voltage VDD signal and the threshold voltage of the fourth transistor M_{4nm} may be charged in the second capacitor C_{2nm} . By storing the voltage corresponding to a sum of the voltage drop of the first voltage VDD signal from the first power source $ELVDD$ and the threshold voltage of the fourth transistor M_{4nm} during operation of the respective $n-1$ pixel of in the m -th column, it is possible to later utilize the stored voltage to compensate for both the voltage drop of the first voltage VDD signal and the threshold voltage during operation of the respective nm -th pixel 140nm.

[0073] In embodiments of the invention, the voltage corresponding to the sum of the threshold voltage of the fourth transistor M_{4nm} and the difference between the reference voltage signal V_{ref} and the first voltage VDD signal may be charged in the second capacitor C_{2nm} before the n th scan signal SS_n is supplied to the n th scan line S_n . When the n th scan signal SS_n is supplied to the n th scan line S_n , the first and second transistors M_{1nm} and M_{2nm} may be turned on. During the first period of one horizontal period, when the second transistor M_{2nm} of the pixel circuit 142nm of the nm -th pixel 140nm is turned on, the PC may be supplied from the nm -th pixel 140nm to the data driving circuit 200 via the data line D_m . In embodiments of the invention, the PC may be supplied to the data driving circuit 200 via the first power source $ELVDD$, the fourth transistor M_{4nm} , the second transistor M_{2nm} and the data line D_m . A predetermined voltage may then be charged in the first and second capacitors C_{1nm} and C_{2nm} in response to the supplied PC .

[0074] The data driving circuit 200 may reset a voltage of a gamma voltage unit (not shown) based on a predetermined voltage value, i.e., compensation voltage that may be generated when the PC sinks, as described above. The reset voltage from the gamma voltage unit (not shown) may be used to generate the data signals DS_1 to DS_m to be respectively supplied to the data lines D_1 to D_m .

[0075] In embodiments of the invention, the generated data signals DS_1 to DS_m may be respectively supplied to the respective data lines D_1 to D_m during the second period of the one horizontal period. More particularly, e.g., the respective generated data signal DS_m may be supplied to the respective first node N_{1nm} via the first transistor M_{1nm} during the second period of the one horizontal period. Then, the voltage corresponding to difference between the data signal DS_m and the first power source $ELVDD$ may be charged in the first capacitor C_{1nm} . The second node N_{2nm} may then float and the second capacitor C_{2nm} may maintain the previously charged voltage.

[0076] In embodiments of the invention, during the period when the $n-1$ pixel in the m -th column is being controlled and the scan signal SS_{n-1} is being supplied to the previous scan line S_{n-1} , a voltage corresponding to the threshold voltage of the fourth transistor M_{4nm} and the voltage drop of the first voltage VDD signal from the first power source $ELVDD$ may be charged in the second capacitor C_{2nm} of the nm -th pixel 140nm to compensate for the voltage drop of the first voltage VDD signal from the first power source $ELVDD$ and the threshold voltage of the fourth transistor M_{4nm} .

[0077] In embodiments of the invention, during the period when the n -th scan signal SS_n is supplied to the n -th scan line S_n , the voltage of the gamma voltage unit (not shown) may be reset so that the electron mobility of the transistors included in the respective n -th pixels 140n associated with each data line D_1 to D_m may be compensated for and the respective generated data signals DS_1 to DS_m may be supplied to the n -th pixels 140n using the respective reset gamma voltages. Therefore, in embodiments of the invention, non-uniformity in the threshold voltages of the transistors and the electron mobility may be compensated, and images with uniform brightness may be displayed. Processes for resetting the voltage of the gamma voltage unit will be described below.

[0078] FIG. 5 illustrates another exemplary embodiment of an nm -th pixel 140nm' employable by the light emitting display illustrated in FIG. 2. The structure of the nm -th pixel 140nm' illustrated in FIG. 5 is substantially the same as the structure of the nm -th pixel 140nm illustrated in FIG. 3, but for the arrangement of a first capacitor C_{1nm}' in a pixel circuit 142nm' and respective connections to a first node N_{1nm}' and a second node N_{2nm}' . In the exemplary embodiment

illustrated in FIG. 5, a first electrode of the first capacitor C1nm' may be connected to the second node N2nm' and a second electrode of the first capacitor C1nm' may be connected to the first power source ELVDD. A first electrode of the second capacitor C2nm may be connected to the first node N1nm' and a second electrode of the second capacitor C2nm may be connected to the second node N2nm'. The first node N1nm' may be connected to the second electrode of the first transistor M1nm, the second electrode of the third transistor M3nm and the first electrode of the second capacitor C2nm. The second node N2nm' may be connected to the gate electrode of the fourth transistor M4nm, the second electrode of the fifth transistor M5nm, the first electrode of the first capacitor C1nm' and the second electrode of the second capacitor C2nm.

[0079] In the following description, the same reference numerals employed above in the description of the nm-th pixel 140nm shown in FIG. 3 will be employed to describe like features in the exemplary embodiment of the nm-th pixel 140nm' illustrated in FIG. 5.

[0080] Exemplary methods for operating the nm-th pixel circuit 142nm' of the nm-th pixel 140nm' of the pixels 140 will be described in detail with reference to FIGS. 4 and 5. First, during a horizontal period for driving the n-1 pixels 140(n-1)(1 to m), i.e., the pixels arranged in the (n-1)th row, when the n-1th scan signal SSn-1 is supplied to the n-1th scan line Sn-1, the third and fifth transistors M3nm and M5nm of the n-th pixel(s) 140(n)(1 to m), i.e., the pixels arranged in the n-th row, may be turned on.

[0081] When the fifth transistor M5nm is turned on, current may flow through the fourth transistor M4nm so that the fourth transistor M4nm may operate as a diode. When the fourth transistor M4nm operates as a diode, a voltage corresponding to a value obtained by subtracting the threshold voltage of the fourth transistor M4nm from the first power source ELVDD may be applied to a second node N2nm'. The voltage corresponding to the threshold voltage of the fourth transistor M4nm may be charged in the first capacitor C1nm'. As shown in FIG. 5, the first capacitor C1nm' may be provided between the second node N2nm' and the first power source ELVDD.

[0082] When the third transistor M3nm is turned on, the voltage of the reference power source ELVref may be applied to the first node N1nm'. Then, the second capacitor C2nm may be charged with the voltage corresponding to difference between a first node N1nm' and the second node N2nm'. During the period where the n-1th scan signal SSn-1 is supplied to the n-1th scan line Sn-1 and the first and second transistors M1nm and M2nm may be turned off, the data signal DSm may not be supplied to the nm-th pixel 140nm'.

[0083] Then, during the first period of the one horizontal period 1H for driving the nm-th pixel 140nm', the scan signal SSn may be supplied to the nth scan line Sn and the first and second transistors M1nm and M2nm may be turned on. When the second transistor M2nm is turned on, during the first period of the one horizontal period, the respective PC may be supplied from the nm-th pixel 140nm' to the data driving circuit 200 via the data line Dm. The PC may be supplied to the data driving circuit 200 via the first power source ELVDD, the fourth transistor M4nm, the second transistor M2nm and the data line Dm. In response to the PC, predetermined voltage may be charged in the first and second capacitors C1nm' and C2nm.

[0084] The data driving circuit 200 may reset the voltage of the gamma voltage unit using the compensation voltage applied in response to the PC to generate the data signal DS using the respectively reset voltage of the gamma voltage unit.

[0085] Then, during the second period of the one horizontal period for driving the nm-th pixel 140nm', the data signal DSm may be supplied to the first node N1nm'. The predetermined voltage corresponding to the data signal DSm may be charged in the first and second capacitors C1nm' and C2nm.

[0086] When the data signal DSm is supplied, the voltage of the first node N1nm' may fall from the voltage Vref of the reference power source ELVref to the voltage of the data signal DSm. At this time, as the second node N2nm' may be floating, the voltage value of the second node N2nm' may be reduced in response to the amount of voltage drop of the first node N1nm'. The amount of reduction in voltage that may occur at the second node N2nm' may be determined by the capacitances of the first and second capacitors C1nm' and C2nm.

[0087] When the voltage of the second node N2nm' falls, the predetermined voltage corresponding to the voltage value of the second node N2nm' may be charged in the first capacitor C1nm'. When the voltage value of the reference power source ELVref is fixed, the amount of voltage charged in the first capacitor C1nm' may be determined by the data signal DSm. That is, in the nm-th pixel 140nm' illustrated in FIG. 5, because the voltage values charged in the capacitors C1nm' and C2nm may be determined by the reference power source ELVref and the data signal DSm, it may be possible to charge a desired voltage irrespective of the voltage drop of the first power source ELVDD.

[0088] In embodiments of the invention, the voltage of the gamma voltage unit may be reset so that the electron mobility of the transistors included in each of the pixels 140 may be compensated for and the respective generated data signal may be supplied using the reset gamma voltage. In embodiments of the invention, non-uniformity among the threshold voltages of the transistors and deviation in the electron mobility of the transistors may be compensated for, thereby enabling images with uniform brightness to be displayed.

[0089] FIG. 6 illustrates a block diagram of a first exemplary embodiment of the data driving circuit illustrated in FIG. 2. For simplicity, in FIG. 6, it is assumed that the data driving circuit 200 has j channels, where j is a natural number equal to or greater than 2.

[0090] As shown in FIG. 6, the data driving circuit 200 may include a shift register unit 210, a sampling latch unit 220, a holding latch unit 230, a decoder unit 240, a digital-analog converter unit (hereinafter, referred to as a DAC) 250, a voltage controller unit 260, a first buffer unit 270, a current supply unit 280, a selector 290 and a gamma voltage unit 300.

[0091] The shift register unit 210 may receive a source shift clock SSC and a source start pulse SSP from the timing controller 150. The shift register unit 210 may utilize the source shift clock SSC and the source start pulse SSP to sequentially generate j sampling signals while shifting the source start pulse SSP every one period of the source shift clock SSC. The shift register unit 210 may include j shift registers 2101 to 210 j .

[0092] The decoder unit 240 may include j decoders 2401 through 240 j . Each of the decoders 2401 through 240 j may receive k bits of the respective first data DATA1 and may convert the k bits of the first data DATA1 into p (p is a natural number) bits of second data DATA2. In embodiments of the invention, each of the decoders 2401 through 240 j may generate p bits of second data DATA2 using a binary weighted value.

[0093] In embodiments of the invention, the weighted value of the externally received first data DATA1 may be determined to allow the gamma voltage unit 300 to be set a predetermined voltage. For example, the number of bits of the first data DATA1 allowing a desired gray scale voltage to be selected from a plurality of gray scale voltages may be determined. The plurality of gray scale voltages may be generated by the gamma voltage unit 300. The decoders 2401 through 240 j may convert k bits of the first data DATA1, corresponding to the gray scale voltages, into respective p bits of second data DATA2-1 to DATA2- j using a binary weighted value. For example, the decoders 2401 through 240 j may generate five bits of the second data DATA2 using eight bits of the first data DATA1.

[0094] In embodiments of the invention, at least one decoder 240 may be provided. The decoder 240 may be connected to the sampling latch unit 220, as shown in FIG. 6. In such embodiments, when the first data DATA1 are sequentially supplied from the timing controller 150, the decoder 240 may receive the first data DATA1 and supply, e.g., the k -bits of first data DATA1 and p -bits of second data DATA2, resulting from the conversion, to the sampling latch unit 220. In embodiments of the invention, when the first data DATA1 corresponding to, e.g., red, green, and blue, are simultaneously input from the timing controller 150, three decoders 240 may be provided and the decoders 240 may be connected to the sampling latch unit 220.

[0095] The sampling latch unit 220 may sequentially store the respective first data DATA1 and the second data DATA2 in response to sampling signals sequentially supplied from the shift register unit 210. The sampling latch unit 220 may include j sampling latches 2201 to 220 j in order to respectively store the j first data DATA1-1 to DATA1- j and the j second data DATA2-1 to DATA2- j . Each of the sampling latches 2201 to 220 j may have a magnitude corresponding to a total number of bits of the first data DATA1 and the second data DATA2. For example, as shown in FIG. 7, in embodiments of the invention in which the first data DATA1 has k bits and the second data has p bits, each of the sampling latches 2201 to 220 j may have a magnitude of $(k+p)$ bits such that the sampling latches 2201 to 220 j may respectively store $(k+p)$ -bits of each of the j first data DATA1-1 to DATA1- j and the j second data DATA2-1 to DATA2- j .

[0096] The holding latch unit 230 may receive the first data DATA1 and the second data DATA2 from the sampling latch unit 220 to store the first data DATA 1 and the second data DATA2 when a source output enable SOE signal is input to the holding latch unit 230. The holding latch unit 230 may supply the first data DATA 1 and/or the second data DATA2 stored therein to the DAC unit 250 and/or the voltage controlling unit 260 when the SOE signal is input. The holding latch unit 230 may include j holding latches 2301 to 230 j in order to store the j first data DATA1-1 to DATA1- j and the j second data DATA2-1 to DATA2- j . Each of the holding latches 2301 to 230 j may have a magnitude corresponding to a total number of bits of the first data DATA1 and the second data DATA2. For example, as shown in FIG. 7, each of the holding latches 2301 to 230 j may have a magnitude of $(k+p)$ bits so that the k bits of each of the j first data DATA1-1 to DATA1- j and the p bits of each of the j second data DATA2-1 to DATA2- j may be respectively stored.

[0097] The current supply unit 280 may sink the predetermined current PC from the respective pixel(s) 140 selected by one of the scan signals SS1 to SS n . The current supply unit 280 may receive the sinking current via the respective one of the data lines D1 through D j , during the first period of each horizontal period.

[0098] In embodiments of the invention, the current supply unit 280 may sink an amount of current corresponding to a minimum amount of current that may be employed by the respective light emitter, e.g., OLED, to emit light of maximum brightness. Then, the current supply unit 280 may supply a predetermined compensation voltage to the voltage controller unit 260. The compensation voltage may be generated while the respective predetermined current PC was sinking. In the exemplary embodiment illustrated in FIG. 6, the current supply unit 280 includes j current sink units 2801 through 280 j .

[0099] The gamma voltage unit 300 may generate predetermined gray scale voltages corresponding to the k bits of the first data DATA1. The gamma voltage unit 300, as shown in FIG. 8, may include a plurality of distribution or voltage dividing resistors R1 through R l and may generate 2^k gray scale voltages. The gray scale voltages generated by the gamma voltage unit 300 may be supplied to the DAC unit 250.

[0100] The DAC unit 250 may include j DACs 2501 through 250 j . The gray scale voltages generated by the gamma voltage unit 300 may be supplied to each of the j DACs 2501 through 250 j . Each of the DACs 2501 through 250 j may select, as a data signal DS, one of the gray scale voltages that may be supplied by the gamma voltage unit 300 based on the respective first data DATA1-1 to DATA1- j supplied from the respective holding latch units 2301 through 230 j . For

example, the DACs 2501 to 250j may respectively select, as a data signal DS, one of the gray scale voltages that may be supplied by the gamma voltage unit 300 based on a number of bits of the respective first data DATA1-1 to DATA1-j.

[0101] The voltage controller unit 260 may include j voltage controllers 2601 through 260j.

[0102] The voltage controllers 2601 through 260j may each receive a compensation voltage, e.g., voltage supplied via the respective current sink unit 2801-280j or the second data DATA2, and a third supply voltage signal VSS'. In embodiments of the invention, a same power source or a different power source may be employed for supplying the second voltage VSS signal and the third supply voltage VSS' signal. The third supply voltage VSS' signal may be supplied to a terminal of the gamma voltage unit 300. The voltage controllers 2601 through 260j, which may receive the compensation voltage and/or the second data DATA2, and the third supply voltage VSS' signal, may control a voltage value of the selected data signal DS so that variations among the pixels 140, such as, variations due to electron mobility, threshold voltage, etc. of transistors included in the respective pixels 140 may be compensated for.

[0103] The first buffer unit 270 may supply the respective data signal DS to the selector 290. As discussed above, the voltage of the respective data signal may be controlled by the voltage control unit 260. In embodiments of the invention, the first buffer unit 270 may include j first buffers 2701 through 270j.

[0104] The selector 290 may control electrical connections between the data lines D1 to Dj and the first buffers 2701 to 270j. The selector 290 may electrically connect the data lines D1 to Dj and the first buffers 2701 to 270j to each other during the second period of the one horizontal period 1H. In embodiments of the invention, the selector 290 may electrically connect the data lines D1 to Dj and the first buffers 2701 to 270j to each other only during the second period. During periods other than the second period, the selector 290 may keep the data lines D1 to Dj and the first buffers 2701 to 270j electrically disconnected from each other.

[0105] The selector 290 may include j switching units 2901 to 290j. The generated respective data signals DS1 to DSj may be respectively supplied from the first buffers 2701 to 270j to the data lines D1 to Dj via the switching units 2901 to 290j. In embodiments of the invention, the selection unit 290 may employ other types of switching units. Fig. 11 illustrates another exemplary embodiment of a switching unit switching unit 290j' that may be employed by the selector 290.

[0106] As shown in FIG. 8, in a second exemplary embodiment, the data driving circuit 200 may include a level shifter 310 that is connected to the holding latch unit 230. The level shifter 310 may include level registers 3101 to 310j and may raise the voltage levels of the first data DATA1 and the second data DATA2 supplied from the holding latch unit 230 and may supply the first data DATA1 and the second data DATA2 to the DAC unit 250 and the voltage controller 260. When the data (not shown) being supplied from an external system to the data driving circuit 200 has high voltage levels, circuit components with high voltage resistant properties should generally be provided, thus, increasing the manufacturing cost. In embodiments of the invention, the data being supplied from an external system to the data driving circuit 200 may have low voltage levels and the low voltage level may be transitioned to a high voltage level by the level shifter 310. In embodiments of the invention the first data DATA1 may correspond to the externally supplied data.

[0107] FIG. 9 illustrates a first embodiment of a connection scheme for connecting the gamma voltage unit 300, the DAC 250j, the voltage controller 260j, the switching unit 290j and the current sink unit 280j shown in FIG. 6 and a pixel 140nj. For simplicity, FIG. 9 only illustrates one channel, i.e., the jth channel, and it is assumed that the data line Dj is connected to an nj-th pixel 140nj according to the exemplary embodiment of the pixel 140nm illustrated in FIG. 3.

[0108] As shown in FIG. 9, the gamma voltage unit 300 may include a plurality of distribution resistors R1 to Rl. The distribution resistors R1 to Rl may be disposed between the reference supply voltage Vref and the third supply voltage VSS'. The distribution resistors R1 to Rl may distribute or divide a voltage supplied thereto. For example, the distribution resistors R1 to Rl may distribute or divide a voltage between the reference supply voltage Vref and the third supply voltage VSS', and may generate a plurality of gray scale voltages V0 through V2^{k-1}. The distribution resistors R1 to Rl may supply the generated gray scale voltages V0 through V2^{k-1} to the DAC 250j. The gamma voltage unit 300 may supply the third supply voltage VSS' to the voltage controller 260j via a third buffer 301.

[0109] The DAC unit 250 may include j DACs 2501 through 250j. The gray scale voltages generated by the gamma voltage unit 300 may be supplied to each of the j DACs 2501 through 250j. Each of the DACs 2501 through 250j may select, as a data signal DS, one of the gray scale voltages V0 to V2^{k-1} that may be supplied by the gamma voltage unit 300 based on the respective first data DATA1. The DAC 250j may select one of the gray scale voltages V0 to V2^{k-1}, as the data signal DS, based on a bit value of the first data DATA1-1 to DATA1-j. The DAC 250j may supply the selected gray scale voltage to the first buffer 270j.

[0110] The DAC 250j may select one gray scale voltage among the gray scale voltages V0 to V2^{k-1} in response to the bit values of the first data Data1 as the data signal DS to supply the data signal DS to the first buffer 270j. A forty-first transistor M41j may be provided between the DAC 250j and the first buffer 270j. A first electrode of the forty-first transistor M41j may be connected to the DAC 250j. A second electrode of the forty-first transistor M41j may be connected to the first buffer 270j. The forty-first transistor M41j may be controlled by a third control signal CS3 supplied to a gate electrode of the forty-first transistor M41j, as illustrated in FIGS. 9 and 10. As shown in FIG. 10, the forty-first transistor M41j may be turned on during a portion of the first period of one horizontal period to supply the data signal DS supplied

from the DAC 250j to the first buffer 270j via the forty-first transistor M41j. As shown in FIG. 10, a voltage of the third control signal CS3 may change, e.g., rise, after a voltage of the second control signal CS2 changes, e.g., rises, and may change again, e.g., fall, at a same time as the voltage of the second control signal CS2 changes again, e.g., falls.

[0111] The current sink unit 280j may include a twelfth transistor M12j and a thirteenth transistor M13j, a current source I_{maxj}, a third capacitor C_{3j}, a third node N_{3j}, a ground voltage source GND and a second buffer 281. The twelfth transistor M12j and the thirteenth transistor M13j may be controlled by the second control signal CS2. The current source I_{maxj} may be connected to a first electrode of the thirteenth transistor M13j. The third capacitor C_{3j} may be connected between the third node N_{3j} and the ground voltage source GND. The second buffer 281j may be connected between the third node N_{3j} and the voltage controller 260j.

[0112] A gate electrode of the twelfth transistor M12j may be connected to a gate electrode of the thirteenth transistor M13j. A second electrode of the twelfth transistor M12j may be connected to a second electrode of the thirteenth transistor M13j and the data line D_j. A first electrode of the twelfth transistor M12j may be connected to the second buffer 281. The twelfth transistor M12j and the thirteenth transistor M13j may be turned on during the first period of each horizontal period 1H. The twelfth transistor M12j and the thirteenth transistor M13j may be turned off during the second period of the horizontal period 1H. The second control signal CS2 may control the on/off state of the twelfth transistor M12j and the thirteenth transistor M13j.

[0113] During the first period of one horizontal period 1H, the current source I_{maxj} may receive, from the pixel 140nj, at least a minimum amount of current that may be supplied to the light emitter, e.g., OLED_{nj}, for the pixel 140nj to emit light with maximum brightness. As discussed above, the second control signal CS2 may control the twelfth transistor M12j and the thirteenth transistor M13j to be on during the first period 1H, thereby allowing the predetermined current PC to flow from the pixel 140nj to the current sink unit 280j. When the twelfth transistor M12j and the thirteenth transistor M13j are on during the first period of one horizontal period, the current source I_{maxj} of the current sink unit 280j may receive an amount of current corresponding to a minimum amount of current that may be supplied to the OLED_{nj} for the pixel 140nj to emit light with maximum brightness. The respective light emitting device, e.g., OLED_{nj}, may emit light of maximum brightness when at least a voltage corresponding to the a highest one of the plurality of gray scale voltages V₀ to V_{2^k-1} is supplied to the light emitting device.

[0114] The third capacitor C_{3j} may store a compensation voltage that may be applied to the third node N_{3j} when the current from the pixel 140nj sinks to the current source I_{maxj}. The third capacitor C_{3j} may store the compensation voltage applied to the third node N_{3j} during the first period of one horizontal period 1H, and may maintain the compensation voltage at the third node N_{3j} stable even when the twelfth transistor M13 and the thirteenth transistor M13 are turned off.

[0115] The second buffer 281j may transfer the compensation voltage applied to the third node N_{3j} to the voltage controller 260j.

[0116] The voltage controller 260j may receive the compensation voltage, the second data Data2 and/or the voltage of the third supply voltage VSS' to control the voltage value of the data signal DS_j. In the description of exemplary embodiments, reference term "p" will be equal to five, however, "p" may be any positive integer.

[0117] To control the voltage value of the data signal DS_j, the voltage controller 260j may include p capacitors C_j, 2C_j, 4C_j, 8C_j and 16C_j, a first set of p PMOS transistors M31j, M32j, M33j, M34j and M35j and a first set of p NMOS transistors M21j, M22j, M23j, M24j and M25j. The capacitors C_j, 2C_j, 4C_j, 8C_j and 16C_j may be connected to an electrical path connecting the forty-first transistor M41 and the first buffer 270j. First electrodes of the first set of p PMOS transistors M31j, M32j, M33j, M34j and M35j may be connected the third buffer 301 and second electrodes of the first set of p PMOS transistors M31j to M35j may be respectively connected to the first electrodes of the p capacitors C_j, 2C_j, 4C_j, 8C_j and 16C_j, respectively. Second electrodes of the p capacitors C_j, 2C_j, 4C_j, 8C_j and 16C_j may be connected to a second electrode of the forty-first transistor M41 and the first buffer 270j. First electrodes of the first set of p NMOS transistors M21j, M22j, M23j, M24j and M25j may be connected to the second buffer 281j and second electrodes of the first set of p NMOS transistors M21j to M25j may be respectively connected to the first electrodes of the p capacitors C_j, 2C_j, 4C_j, 8C_j and 16C_j. Gate electrodes of the first set of p NMOS transistors M21j to M25j may be respectively connected to gate electrodes of the first set of p PMOS transistors M31j to M35j.

[0118] Capacitance values of the p capacitors C_j, 2C_j, 4C_j, 8C_j and 16C_j may be relative to each other such that the capacitances of the p capacitors may increase along the order of 2⁰, 2¹, 2², 2³ and 2⁴, respectively. For example, the capacitances of the p capacitors C_j, 2C_j, 4C_j, 8C_j and 16C_j may have respective binary weighted values in accordance with the second data DATA2.

[0119] As shown in FIG. 9, the voltage controller 260j may include a second set of, e.g., p NMOS transistors M51j, M52j, M53j, M54j and M55j and a second set of, e.g., p PMOS transistors M61j, M62j, M63j, M64j and M65j. First electrodes of the second set of p NMOS transistors M51j to M55j may be connected to the ground voltage source GND. First electrodes of the second set of p PMOS transistors M61j to M65j may be connected to, e.g., the holding latch unit 230j or the level shifter 310j and may receive the second data DATA2. Second electrodes of the second set of p NMOS transistors M51j, M52j, M53j, M54j and M55j may be respectively connected to the gate electrodes of the first set of p PMOS transistors M31j to M35j and the gate electrodes of the first set of p NMOS transistors M21j to M25j. Gate

electrodes of the second set of p NMOS transistors M51j to M55j may be respectively connected to gate electrodes of the second set of p PMOS transistors M61j to M65j.

[0120] As illustrated in FIG. 10, a fourth control signal CS4 may control the second set of p NMOS transistors M51j to M55j. The fourth control signal CS4 may turn on the second set of p NMOS transistors M51j to M55j during the first period of one horizontal period 1H and may turn off the second set of p NMOS transistors M51j to M55j during the second period of the horizontal period.

[0121] The second set of p NMOS transistors M51j to M55j may be turned on during the first period by the fourth control signal CS4. When the second set of p NMOS transistors are turned on, voltage from the ground voltage source GND may be supplied to the gate electrodes of the first set of p PMOS transistors M31j to M35j. Thus, the first set of p PMOS transistors M31j to M35j may be turned on during the first period of one horizontal period 1H. When the first set of p PMOS transistors M31j to M35j are turned on, voltage from the third supply voltage VSS' may be supplied via the third buffer 301 to the first electrodes of each of the fourth capacitors C, 2C, 4C, 8C, and 16C.

[0122] In embodiments of the invention, the first set of p PMOS transistors are formed of PMOS transistors and the second set of p NMOS transistors are formed of NMOS transistors, however, embodiments of the invention are not limited to such devices. In embodiments of the invention, a conduction type, e.g., P-type or N-type, of the first set of p PMOS transistors may be opposite from a conduction type of the second set of p NMOS transistors.

[0123] The second set of p PMOS transistors M61j to M65j may supply the second data DATA2 to the gate electrodes of the first set of p PMOS transistors M31j to M35j and the gate electrodes of the first set of p NMOS transistors M21j to M25j. In embodiments of the invention, the sixty-first transistor M61j of the second set of p PMOS transistors may receive a bit having a lowermost weight value in the second data DATA2 to supply the lowermost weight value bit to the twenty-fifth transistor M25j of the first set of p NMOS transistors. Depending on a value of the bit having the lowermost weight value, the twenty-fifth transistor M25j may be turned on or off. In embodiments of the invention, the twenty-fifth transistor M25j of the first set of p NMOS transistors may be turned on when the bit having the lowermost weight value is 1 and may be turned off when the bit having the lowermost weight value is 0.

[0124] The sixty-second transistor M62j of the second set of p PMOS transistors may receive a bit having a second lowermost weight value in the second data DATA2 to supply the second lowermost weight value bit to the twenty-fourth transistor M24j of the first set of p NMOS transistors. The sixty-third transistor M63j of the second set of p PMOS transistors may receive a bit having a third lowermost weight value in the second data DATA2 to supply the third lowermost weight value bit to the twenty-third transistor M23j of the first set of p NMOS transistors. The sixty-fourth transistor M64j of the second set of p PMOS transistors may receive a bit having a fourth lowermost weight value in the second data DATA2 to supply the fourth lowermost weight value bit to the twenty-second transistor M22j of the first set of p NMOS transistors. The sixty-fifth transistor M65j of the second set of p PMOS transistors may receive a bit having an uppermost weight value in the second data DATA2 to supply the uppermost weight value bit to the twenty-first transistor M21j of the first set of p NMOS transistors. The second set of p PMOS transistors M61j to M65j may be formed of PMOS transistors and may be controlled by the fourth control signal CS4 such that, as shown in FIG. 10, second set of p PMOS transistors M61j to M65j may be turned off during a first period of one horizontal period 1H and may be turned on during a second period of the one horizontal period 1H.

[0125] The first set of p NMOS transistors M21j to M25j may be turned on when, e.g., a respective bit of the second data DATA2 having a value of 1 is supplied to the respective gate electrode from the second set of p PMOS transistors M61j to M65j, respectively. When the first set of p NMOS transistors M21j to M25j are turned on, the corresponding compensation voltage may be respectively supplied to the first electrode of the fourth capacitors Cj, 2Cj, 4Cj, 8Cj, and 16Cj.

[0126] When the compensation voltage is applied to at least one of the first electrodes of the fourth capacitors Cj, 2Cj, 4Cj, 8Cj and 16Cj, a voltage value of the data signal DSj applied to a line between the forty-first transistor M41j and the first buffer 270j increases or decreases. The voltage value of the data signal DSj increases or decreases based on the value of the compensation voltage. Thus, the voltage value of the data signal DSj is controlled by the respective compensation voltage generated by the pixel currently 140nj being driven and the voltage value of the data signal DSj is controlled so that differences in characteristics, e.g., electron mobility, of the transistors included in the pixel 140nj may be compensated for. In embodiments of the invention, the pixel unit 130 may display images with uniform brightness at least because the voltage value of the respective data signal DSj supplied to the pixels 140(1j) to 140(nj) may be controlled by the respective compensation voltage determined by the respective pixel 140(1j) to 140(nj) being driven and thus, differences in characteristics, e.g., electron mobility, may be compensated for.

[0127] The first buffer 270j may transmit the data signal DSj applied to the line between the forty-first transistor M41j and the first buffer 270j to the switching unit 290j.

[0128] The switching unit 290j may include an eleventh transistor M11j. The eleventh transistor M11j may be controlled by the first control signal CS1, as shown in FIGS. 9 and 10. In embodiments of the invention, the eleventh transistor M11j may be turned on during the second period of each horizontal period 1H for driving each of the n pixels in the j-th channel. In such embodiments, the eleventh transistor M11j may be turned off during the first period of each horizontal period 1H for driving each of the n pixels in the j-th channel. Thus, the data signal DSj may be supplied to the data line Dj

during the second period of the horizontal period 1H and may not be supplied during other periods, e.g., the first period, of a single horizontal period 1H. In embodiments of the invention, the data signal DS_j may only be supplied during the second horizontal period of a single horizontal period 1H. In embodiments of the invention, the data signal DS_j may never be supplied to the data line D_j during the first period of a single horizontal period 1H.

[0129] FIG. 10 illustrates driving waveforms supplied to the switching unit, the current sink unit, the forty-first transistor, and the voltage controller 260_j illustrated in FIG. 9.

[0130] FIG. 10 illustrates exemplary waveforms employable for driving the pixel, the switching unit and the current sink unit illustrated in FIG. 9. Exemplary methods for controlling the voltage of data signals DS respectively supplied to the pixels 140 will be described in detail with reference to FIGS. 9 and 10. In the exemplary embodiment illustrated in FIG. 9, the pixel 140_{nj} and the pixel circuit 142_{nj}, according to the exemplary embodiment illustrated in FIG. 3, is provided. In the following description, the same reference numerals employed above in the description of the n_m-th pixel 140_{nm} shown in FIG. 3 will be employed to describe like features in the exemplary embodiment of the n_j-th pixel 140_{nj} illustrated in FIG. 9.

[0131] First, the scan signal SS_{n-1} may be supplied to the n-1th scan line S_{n-1}. When the scan signal SS_{n-1} is supplied to the n-1th scan line S_{n-1}, the third and fifth transistors M3_{nj} and M5_{nj} may be turned on. The voltage value obtained by subtracting the threshold voltage of the fourth transistor M4_{nj} from the first power source ELVDD may then be applied to a second node N2_{nj} and the voltage of the reference power source ELVref may be applied to a first node N1_{nj}. The voltage corresponding to the voltage drop of the first power source ELVDD and the threshold voltage of the fourth transistor M4_{nj} may then be charged in the second capacitor C2_{nj}. In the following description, it will be assumed that VSS equals VSS'.

[0132] The voltages applied to the first node N1_{nj} and the second node N2_{nj} may be represented by EQUATION 1 and EQUATION2.

[EQUATION1]

$$V_{N1} = V_{ref}$$

[EQUATION2]

$$V_{N2} = ELVDD - |V_{thM4}|$$

[0133] In EQUATION1 and EQUATION2, V_{N1}, V_{N2}, and V_{thM4} represent the voltage applied to the first node N1_{nj}, the voltage applied to the second node N2_{nj}, and the threshold voltage of the fourth transistor M4_{nj}, respectively.

[0134] From the time when the scan signal SS_{n-1} is supplied to the n-1th scan line S_{n-1} is turned off, e.g., changed from a low voltage signal to a high voltage signal, to the time when the scan signal SS_n is supplied, e.g., changed from a high voltage signal to a low voltage signal, to the n_mth scan line S_{nj}, the first and second nodes N1_{nj} and N2_{nj} may be floating. Therefore, the voltage value charged in the second capacitor C2_{nj} may not change during that time.

[0135] The n_m-th scan signal SS_n may then be supplied to the n_mth scan line S_n so that the first and second transistors M1_{nj} and M2_{nj} may be turned on. When the scan signal SS_n is being supplied to the n_mth scan line S_n, during the first period of the one horizontal period 1H when the n_m-th scan line S_n is being driven, the twelfth and thirteenth transistors M12_j and M13_j may be turned on. When the twelfth and thirteenth transistors M12_j and M13_j are turned on, the current that may flow through the current source I_{maxj} via the first power source ELVDD, the fourth transistor M4_{nj}, the second transistor M2_{nj}, the data line D_j, and the thirteenth transistor M13_j may sink.

[0136] When current flows through the current source I_{maxj} via the first power source ELVDD, the fourth transistor M4_{nj} and the second transistor M2_{nj}, EQUATION3 may apply.

[EQUATION3]

$$I_{max} = \frac{1}{2} \mu_p C_{ox} \frac{W}{L} (ELVDD - V_{N2} - |V_{thM4}|)^2$$

[0137] In EQUATION3, μ , C_{ox} , W and L represent the electron mobility, the capacity of an oxide layer, the width of a channel and the length of a channel, respectively.

[0138] The voltage applied to the second node $N2_{nj}$ when the current obtained by EQUATION3 flows through the fourth transistor $M4_{nj}$ may be represented by EQUATION4.

[EQUATION4]

$$V_{N2} = ELVDD - \sqrt{\frac{2I_{max}}{\mu_p C_{ox}} \frac{L}{W} - |V_{thM4}|}$$

[0139] The voltage applied to the first node $N1_{nj}$ may be represented by EQUATION5 by the coupling of the second capacitor $C2_{nj}$.

[EQUATION5]

$$V_{M1} = V_{ref} - \sqrt{\frac{2I_{max}}{\mu_p C_{ox}} \frac{L}{W}} = V_{N3}$$

[0140] In EQUATION5, the voltage V_{N1} may correspond to the voltage applied to the first node $N1_{nj}$ and the voltage V_{N3} may correspond to the voltage applied to the third node $N3_j$. In embodiments of the invention, when current sinks by the current source I_{max_j} , a voltage satisfying EQUATION5 may be applied to the third node $N3_j$.

[0141] As seen in EQUATION5, the voltage applied to the third node $N3_j$ may be affected by the electron mobility of the transistors included in the pixel 140_{nj} , which is supplying current to the current source I_{max_j} . Therefore, the voltage value applied to the third node $N3_j$ when the current is being supplied to the current source I_{max_j} may vary in each of the pixels 140, e.g., when the electron mobility varies in each of the pixels 140.

[0142] During the first period of a horizontal period $1H$ for driving each of the pixels 140, the DAC 250 may select an h -th one of f gray scale voltages based on the first data $DATA1$ for respective pixels, where h and f are natural numbers. For example, the DAC 250j may select the h -th one of f gray scale voltages corresponding to the first data $DATA1$ for the n_j -th pixel 140_{nj} . Then, when the forty-first transistor $M41$ is turned on, the DAC 250j together with the voltage controller 260j may selectively apply the selected h -th one of the f gray scale voltages, as the data signal DS_j , to the electrical connection between the forty-first transistor $M41_j$ and the first buffer 270j. A voltage applied to the electrical connection between the forty-first transistor $M41$ and the first buffer 270j may be expressed by EQUATION6.

[EQUATION6]

5

$$V_L = V_{ref} - \frac{h}{f}(V_{ref} - V_{SS})$$

10

[0143] In embodiments of the invention including the second set of p NMOS transistors M51j to M55j, the second set of p NMOS transistors M51j to M55j may be turned on by the fourth control signal CS4 during the first period of one horizontal period so that a voltage of the ground voltage source GND may be supplied to respective gate electrodes of the first set of p PMOS transistors M31j to M35j. Then, the first set of p PMOS transistor M31j to M35j may be turned on so that the first electrode of each of the fourth capacitors Cj, 2Cj, 4Cj, 8Cj and 16Cj may be set to have the voltage value of the third supply voltage VSS. In embodiments of the invention, the voltage value of the third supply voltage VSS may be set to be smaller than the voltage value of the reference power source Vref. In embodiments of the invention, the third supply voltage VSS may be set to an average voltage of compensation voltages that may be generated by the pixels 140 included in the pixel unit 130.

15

20

[0144] After the first electrodes of the fourth capacitors Cj, 2Cj, 4Cj, 8Cj and 16Cj are set to have the voltage value of the third supply voltage VSS, the second set of p PMOS transistors M61j to M65j may be turned on during the second period of the one horizontal period. When the second set of p PMOS transistors M61j to M65j are turned on, bits of the second data DATA2 may be respectively supplied to the p NMOS transistors M21j to M25j of the first set of p NMOS transistors M21j to M25j. For example, when p bits of the second data DATA2 are set as 00011, the twenty-fourth transistor M24j and the twenty-fifth transistor M25j of the first set of p NMOS transistors M21j to M25j are turned during the second period of the one horizontal period when the second set of p PMOS transistors M61j to M65j are turned on. Then, the respective compensation voltages may be applied to the first electrode(s) of the fourth capacitors Cj, 2Cj, 4Cj, 8Cj and 16Cj. In the example of the second data DATA2 having a value of 00011, because the compensation voltage is applied to the respective first electrodes of first and second capacitors Cj and 2Cj, and EQUATION 6 may be obtained.

25

30

[EQUATION 6]

$$\frac{C + 2C}{C + 2C + 4C + 8C + 16C} = \frac{h}{f}$$

35

[0145] More particularly, as discussed above, because the second data DATA2 may be generated by changing weight values of the first data DATA1, a value satisfying EQUATION7 approximates the value of h/f.

40

[0146] Meanwhile, if the compensation voltage is applied to at least one of the p capacitors Cj, 2Cj, 4Cj, 8Cj and 16Cj, a voltage of the electrical connection between the forty-first transistor M41j and the first buffer 270j may be expressed by EQUATION8.

45

50

55

[EQUATION8]

$$\begin{aligned}
V_L &= V_{ref} - \frac{h}{f} (V_{ref} - V_{SS}) + V_{boost} & V_{boost} &= \frac{h}{f} (V_{N3} - V_{SS}) \\
&= V_{ref} - \frac{h}{f} (V_{ref} - V_{N3}) \\
&= V_{ref} - \frac{h}{f} \sqrt{\frac{2I_{max}}{\mu_p C_{OX}} \frac{L}{W}}
\end{aligned}$$

[0147] A voltage satisfying EQUATION8 may be supplied to the eleventh transistor M11j via the first buffer 270j. During the second period of the one horizontal period 1H, because the eleventh transistor M11j may be turned on, the voltage supplied to the first buffer 270j may be supplied to the first node N1nj via the eleventh transistor M11j, the data line Dj, and the first transistor M1nj. The voltage satisfying EQUATION8 may be supplied to the first node N1nj. A voltage applied to the second node N2nj by coupling of the second capacitor C2nj can be expressed by EQUATION9.

[EQUATION 9]

$$V_{N2} = ELVDD - \frac{h}{f} \sqrt{\frac{2I_{max}}{\mu_p C_{OX}} \frac{L}{W}} - |V_{thM4}|$$

[0148] Here, current flowing through the fourth transistor M4nj may be expressed by EQUATION10.

[EQUATION10]

$$\begin{aligned}
I_{N4} &= \frac{1}{2} \mu_p C_{OX} \frac{W}{L} (ELVDD - V_{N2} - |V_{thM4}|)^2 \\
&= \frac{1}{2} \mu_p C_{OX} \frac{W}{L} \left(ELVDD - \left(ELVDD - \frac{h}{f} \sqrt{\frac{2I_{max}}{\mu_p C_{OX}} \frac{L}{W}} - |V_{thM4}| \right) - V_{thM4} \right)^2 \\
&= \left(\frac{h}{f} \right)^2 I_{max}
\end{aligned}$$

[0149] Referring to EQUATION10, in embodiments of the invention, current flowing through the fourth transistor M4nj may depend on the respective data signal DS supplied to the respective pixel 140 and more particularly, the gray scale voltage generated by the voltage controller 260j. Therefore, in embodiments of the invention, by supplying a current based on a compensation voltage generated by current sinking from the respective pixel 140nj, a desired current may be selected and supplied as the respective data signal DS, irrespective of threshold voltage, electron mobility, etc. of the transistors, e.g., M4nj, of the respective pixel. Thus, embodiments of the invention enable uniform images to be displayed irrespective of variations in electron mobility and threshold voltage within and among the pixels 140 of the pixel unit 130.

[0150] In embodiments of the invention, as discussed above, different switching units may be employed. FIG. 11 illustrates the connection scheme illustrated in FIG. 9 employing another embodiment of a switching unit 290j'. The exemplary connection scheme illustrated in FIG. 11 is substantially the same as the exemplary connection scheme illustrated in FIG. 9, but for another exemplary embodiment of the switching unit 290j'. In the following description, the same reference numerals employed above will be employed to describe like features in the exemplary embodiment illustrated in FIG. 11.

[0151] As shown in FIG. 11, another exemplary switching unit 290j' may include eleventh and fourteenth transistors M11j, M14j that may be connected to each other in the form of a transmission gate. The fourteenth transistor M14j, which may be a PMOS type transistor, may receive the second control signal CS2. The eleventh transistor M11j, which may be a NMOS type transistor, may receive the first control signal CS 1. In such embodiments, when the polarity of the first control signal CS1 is opposite to the polarity of the second control signal CS2, the eleventh and fourteenth transistors M11j and M14j may be turned on and off at the same time.

[0152] In embodiments of the invention in which the eleventh and fourteenth transistors M11j and M 14j may be connected to each other in the form of the transmission gate. In such embodiments, a voltage-current characteristic curve may be in the form of a straight line and switching error may be minimized.

[0153] FIG. 12 illustrates a schematic diagram of a second embodiment of a connection scheme connecting a gamma voltage unit 300, a digital-to-analog converter unit 250j, a switching unit 290j, a voltage controlling unit 260j and a current sink unit 280j illustrated in FIG. 6, and a pixel 140nj', as illustrated in FIG. 5. For simplicity, FIG. 12 only illustrates one channel, i.e., the jth channel and it is assumed that the data line Dj is connected to the nj-th pixel 140nj' according to the exemplary embodiment of the pixel 140nm' illustrated in FIG. 5.

[0154] Methods for driving pixels 140 of a light emitting display will be described in detail with reference to FIGS. 10 and 12. First, when a scan signal SSn-1 is supplied to the n-1th scan line Sn-1, a voltage satisfying EQUATION1 and EQUATION2 may be applied to a first node N1nj' and a second node N2nj', respectively.

[0155] The n-th scan signal may be applied to the n-th scan line Sn. During the first period of a horizontal period 1H for driving the nj-th pixel 140nj', w when the twelfth transistor M12j and the thirteenth transistor M13j may be turned on, current flowing through the fourth transistor M4j may satisfy EQUATION3 and a voltage applied to the second node N2nj' may satisfy EQUATION4. In the following description, the same reference numerals employed above in the description of the exemplary embodiment illustrated in FIG. 9 will be employed to describe like features in the exemplary embodiment of the connection scheme illustrated in FIG. 12.

[0156] A voltage applied to the first node N1nj' by coupling of the second capacitor C2nj can be expressed by EQUATION11.

[EQUATION11]

$$V_{N1} = V_{ref} - \left(\frac{C1+C2}{C2} \right) \sqrt{\frac{2I_{max}}{\mu_p C_{ox}} \frac{L}{W}} = V_{N3}$$

[0157] Meanwhile, during the first period of the horizontal period for driving the nj-th pixel 140nj', the DAC 250j may select an h-th one of f gray scale voltages in accordance with the first data DATA1, where h and f are natural numbers. The DAC 250j may also supply a gray scale voltage satisfying EQUATION6. The selected h-th one of the f gray scale voltages may be supplied to first buffer 270j when the forty-first transistor M41j is turned on. The selected h-th one of the f gray scale voltages may be selected, as a respective data signal DSj to be supplied to the pixel 140nj' via the data line Dj.

[0158] The decoder 240j may supply an initialization signal to the thirty-first transistor M31j, the thirty-second transistor M32j, the thirty-third transistor M33j, the thirty-fourth transistor M34j and the thirty-fifth transistor M35j and may thereby turn on each of the p transistors M31j, M32j, M33j, M34j and M35j during the first period of the horizontal period 1H for

driving the pixel 140nj'. Thus, during the first period of the one horizontal period 1H, a voltage of a terminal of each of the p capacitors Cj, 2Cj, 4Cj, 8Cj and 16Cj may be to the third supply voltage VSS.

[0159] As discussed above, the second set of p PMOS transistors M61j to M65j may be turned on during the second period of the one horizontal period. When the second set of p PMOS transistors M61j to M65j are turned on, the twenty-first, twenty-second, twenty-third, twenty-fourth and twenty-fifth transistors M21j, M22j, M23j, M24j and M25j of the first set of p NMOS transistors are turned on or off based on respective bit values of the second data DATA2. The first set of p NMOS transistors M21j to M25j may be turned on and off to obtain a value approximating to the value of h/f in EQUATION6.

[0160] At this time, a voltage V_L of the electrical connection between the forty-first transistor M41 and the first buffer 270j may be expressed by EQUATION12.

[EQUATION12]

$$V_L = V_{ref} - \frac{h}{f} (V_{ref} - V_{SS}) + V_{boost} \quad V_{boost} = \frac{h}{f} (V_{N3} - V_{SS})$$

$$= V_{ref} - \frac{h}{f} (V_{ref} - V_{N3})$$

$$= V_{ref} - \frac{h}{f} \left(\frac{C1 + C2}{C2} \right) \sqrt{\frac{2I_{max}}{\mu_p C_{OX}} \frac{L}{W}}$$

[0161] A voltage satisfying EQUATION12 may be supplied to the eleventh transistor M11j via the first buffer 270j. During the second period of the horizontal period 1H for driving the pixel 140nj', because the eleventh transistor M11j may be turned on, the voltage supplied to the first buffer 270j may be supplied to the first node N1nj' via the eleventh transistor M11j, the data line Dj and the first transistor M1j. In embodiments of the invention, a voltage satisfying EQUATION12 may be supplied to the first node N1nj'.

[0162] A voltage applied to the second node N2nj' by the coupling of the second capacitor C2nj may be expressed by EQUATION9. Accordingly, current flowing through the fourth transistor M4nj may be expressed by EQUATION10. In embodiments of the invention, the current corresponding to the gray scale voltage selected by the DAC 250j may flow to the fourth transistor M4nj irrespective of the threshold voltage and electron mobility of the fourth transistor M4nj. As discussed above, embodiments of the invention enable the display of images with uniform brightness.

[0163] In some embodiments of the invention, e.g., embodiments employing the pixel 140nj' illustrated in FIG. 12, the voltage of the second node N2nj' may change gradually although the voltage of the first node N1nj' may change rapidly, i.e., (C1+C2)/C2. When the pixel 140nj' illustrated in FIG. 12 is employed, a greater voltage range may be set for the voltage generator 240j than a voltage range that may be set for the voltage generator 240j when the pixel 140nj illustrated in FIG. 9 is employed. As discussed above, when the voltage range of the voltage generator 240j is set to be larger, it is possible to reduce the influence of the switching error of the eleventh transistor M11j and the first transistor M1nj.

[0164] Accordingly, the pixel structure 140nj' shown in FIG. 5 can extend an available voltage range of the gamma voltage unit 300, compared with the pixel structure 140nj shown in FIG. 3. As such, by extending the available voltage range of the gamma voltage unit 300, it is possible to reduce influences by switching errors of the eleventh transistor M11j, the first transistor M1nj, etc.

[0165] As described above, in data driving circuits, data driving methods and light emitting displays employing one or more aspects of embodiments of the invention, because a voltage of a data signal is reset using a compensation voltage generated when current sinks from a respective pixel, uniform images can be displayed regardless of electron mobility, threshold voltages, etc. of transistors.

[0166] Exemplary embodiments of the present invention have been disclosed herein, and although specific terms are employed, they are used and are to be interpreted in a generic and descriptive sense only and not for purpose of limitation.

Accordingly, it will be understood by those of ordinary skill in the art that various changes in form and details may be made without departing from the scope of the present invention as set forth in the following claims.

5 **Claims**

1. A data driving circuit, comprising:

10 converting means for generating second data having p bits using externally supplied first data having k bits;
 latching means for storing the first data and the second data;
 selecting means for selecting one gray scale voltage among a plurality of gray scale voltages as a data signal based on the first data;
 current receiving means for receiving a predetermined current from a pixel during a first partial period of a complete period for driving the pixel based on the selected gray scale voltage;
 15 controlling means for controlling a voltage value of the data signal based on a compensation voltage generated based on the predetermined current and the second data; and
 supplying means for supplying the controlled data signal to the pixel during a second partial period of the one complete period, the second partial period being different from the first partial period and the second partial period elapsing after the first partial period.

20 2. A data driving circuit according to Claim 1, wherein the latching means has a magnitude of k+p bits.

3. A data driving circuit according to Claim 1, further comprising:

25 a gamma voltage unit for generating a plurality of gray scale voltages,

wherein:

30 the connecting means comprises a decoder ;
 the latching means comprises a latch;
 the selecting means comprises a digital-to-analog converter;
 the current receiving means comprises a current sink unit;
 the controlling means comprises a voltage controller; and
 the supplying means comprises a switching unit.

35 4. A data driving circuit according to claim 3, wherein the decoder is arranged to convert the first data into a binary weighted value to generate the second data.

40 5. A data driving circuit according to claim 3 or 4, further comprising:

a first transistor disposed between the digital-analog converter and the switching unit, the digital-analog converter being arranged to be turned on during a predetermined time of the first partial period to transfer the data signal, with the controlled voltage value, to the switching unit; and
 a first buffer connected between the first transistor and the switching unit.

45 6. A data driving circuit according to claim 5, wherein the gamma voltage unit comprises:

a plurality of distribution resistors for generating the gray scale voltages and distributing a reference supply voltage and a first supply voltage; and
 50 a second buffer for supplying the first supply voltage to the voltage controller.

7. A data driving circuit according to claim 6, wherein the voltage controller comprises:

55 p capacitors, each of the capacitors having a first terminal connected to an electrical path between the first transistor and the first buffer;
 second transistors respectively connected between a second terminal of each of the p capacitors and the second buffer;
 third transistors connected respectively between the second terminals of the p capacitors and the current sink

unit and having a conduction type different from a conduction type of the second transistors;
 fourth transistors connected between the second transistors and a predetermined voltage source and having
 a same conduction type as the conduction type of the second transistors; and
 fifth transistors having a same conduction type as the conduction type of the third transistors, the fifth transistors
 for supplying the second data to the second transistors.

8. A data driving circuit according to claim 7, wherein the fourth transistors are turned on during the first period so that
 the second transistors are arranged to be turned on to supply a voltage of the predetermined voltage source to gate
 electrodes of the second transistors.

9. A data driving circuit according to claim 8, wherein the predetermined voltage source is a ground voltage source.

10. A data driving circuit according to any one of claims 7 to 9, wherein the third transistors are arranged to be selectively
 turned on during the first partial period so that the second terminals of the capacitors are set to have the voltage of
 the predetermined voltage source.

11. A data driving circuit according to any one of claims 7 to 10,
 wherein the fifth transistors consist of p transistors, corresponding to the number of bits of the second data, and
 wherein the fifth transistors are arranged to respectively supply different bits of the p bits of second data to the
 second transistors.

12. A data driving circuit according to any one of claims 7 to 11, wherein each of the third transistors arranged to receive
 a bit having a value of 1 is turned on to supply the respective compensation voltage to the second terminals of the
 respective p capacitors.

13. A data driving circuit according to any one of claims 7 to 12, wherein capacitances of the p capacitors are set to
 binary weighted values.

14. A data driving circuit according to any one of claims 3 to 13, wherein the current sink unit comprises:

a current source arranged to provide the predetermined current;
 a first transistor provided between a data line connected to the pixel and the voltage controller, the first transistor
 being turned on during the first partial period;
 a second transistor provided between the data line and the current source, the second transistor being arranged
 to be turned on in the first partial period;
 a capacitor for charging the compensation voltage; and
 a buffer provided between the first transistor and the voltage controller to selectively transmit the compensation
 voltage to the voltage controller.

15. A data driving circuit according to claim 14, wherein the predetermined current is equal to a current value of a
 minimum current flowing through the pixel when the pixel emits light with maximum brightness, and maximum
 brightness corresponds to a brightness of the pixel when a highest one of the plurality of reset gray scale voltages
 is applied to the pixel.

16. A data driving circuit according to any one of claims 3 to 15, wherein the switching unit comprises at least one
 transistor that is arranged to be turned on during the second partial period.

17. A data driving circuit according to claim 16, wherein the switching unit comprises two transistors which are connected
 so as to form a transmission gate.

18. A data driving circuit according to any one of claims 3 to 17, further comprising a shift register unit including at least
 one shift register arranged to sequentially generate sampling pulses and to supply the sampling pulses to the latch
 unit.

19. A data driving circuit according to claim 18, wherein the latch unit comprises:

a sampling latch unit including at least one sampling latch for receiving the first and second data in response
 to the sampling pulses; and

a holding latch unit including at least one holding latch for receiving the first and second data stored in the sampling latch unit to supply the first data stored therein to the digital-to-analog converter and to supply the second data to the voltage controller.

5 **20.** A data driving circuit according to claim 19, wherein each of the sampling latches and the holding latches has a magnitude of $k+p$ bits.

21. A data driving circuit according to claim 19 or 20, further comprising a level shifter unit for increasing voltage levels of the first data and the second data stored in the holding latch to respectively supply the adjusted voltage levels of the stored first data and the stored second data to the digital-to-analog converter and the voltage controller.

22. A light emitting display comprising:

15 a pixel unit including a plurality of pixels connected to n scan lines, a plurality of data lines, and a plurality of emission control lines;

a scan driver arranged to respectively and sequentially supply, during each scan cycle, n scan signals to the n scan lines, and to sequentially supply emission control signals to the plurality of emission control lines; and a data driver having at least one data driving circuit for respectively supplying data signals to the data lines, wherein the or each data driving circuit is according to any one of claims 1 to 21.

20 **23.** A light emitting display according to claim 22, wherein each of the pixels is connected to two of the n scan lines, and during each of the scan cycles, a first of the two scan lines is arranged to receive a respective one of the n scan signals before a second of the two scan lines is arranged to receive a respective one of the n scan signals, and each of the pixels comprises:

25 a first power source;

a light emitter is arranged to receive current from the first power source;

30 first and second pixel transistors each having a first electrode connected to the respective one of the data lines associated with the pixel, the first and second pixel transistors being arranged to be turned on when the first of the two scan signals is supplied;

a third pixel transistor having a first electrode connected to a reference power source and a second electrode connected to a second electrode of the first pixel transistor, the third pixel transistor being arranged to be turned on when the first of the two scans signal is supplied;

35 a fourth pixel transistor arranged to control an amount of current supplied to the light emitter, a first terminal of the fourth pixel transistor being connected to the first power source; and

a fifth pixel transistor having a first electrode connected to a gate electrode of the fourth pixel transistor and a second electrode connected to a second electrode of the fourth pixel transistor, the fifth transistor being arranged to be turned on when the first of the two scan signals is supplied such that the fourth pixel transistor is arranged to operate as a diode.

40 **24.** A light emitting display according to claim 21, wherein each of the pixels comprises:

45 a first pixel capacitor having a first electrode connected to one of a second electrode of the first pixel transistor or the gate electrode of the fourth pixel transistor and a second electrode connected to the first power source; and a second pixel capacitor having a first electrode connected to the second electrode of the first pixel transistor and a second electrode connected to the gate electrode of the fourth pixel transistor.

50 **25.** A light emitting display according to claim 21 or 22, wherein each of the pixels further comprises a sixth pixel transistor having a first terminal connected to the second electrode of the fourth pixel transistor and a second terminal connected to the light emitter, the sixth pixel transistor being arranged to be turned off when the respective emission control signal is supplied,

55 wherein the current sink is arranged to receive the predetermined current from the pixel during a first partial period of one complete period for driving the pixel, the first partial period arranged to occur before a second partial period of the complete period for driving the pixel, and the sixth pixel transistor is arranged to be turned on during the second partial period of the complete period for driving the pixel.

26. A method for driving a light emitting display comprising:

EP 1 750 247 A2

generating second data having p bits using externally supplied first data having k bits; storing the first data and the second data;
selecting one gray scale voltage among a plurality of gray scale voltages as a data signal based on the first data;
receiving a predetermined current from a pixel during a first partial period of a complete period for driving the
5 pixel based on the selected gray scale voltage;
controlling a voltage value of the data signal based on a compensation voltage generated based on the predetermined current under the second data; and
supplying the controlled data signal to the pixel during a second partial period of the one complete partial period,
10 the second partial period being different from the first partial period and to the second partial period elapsing after the first partial period.

5

10

15

20

25

30

35

40

45

50

55

FIG. 1
(RELATED ART)

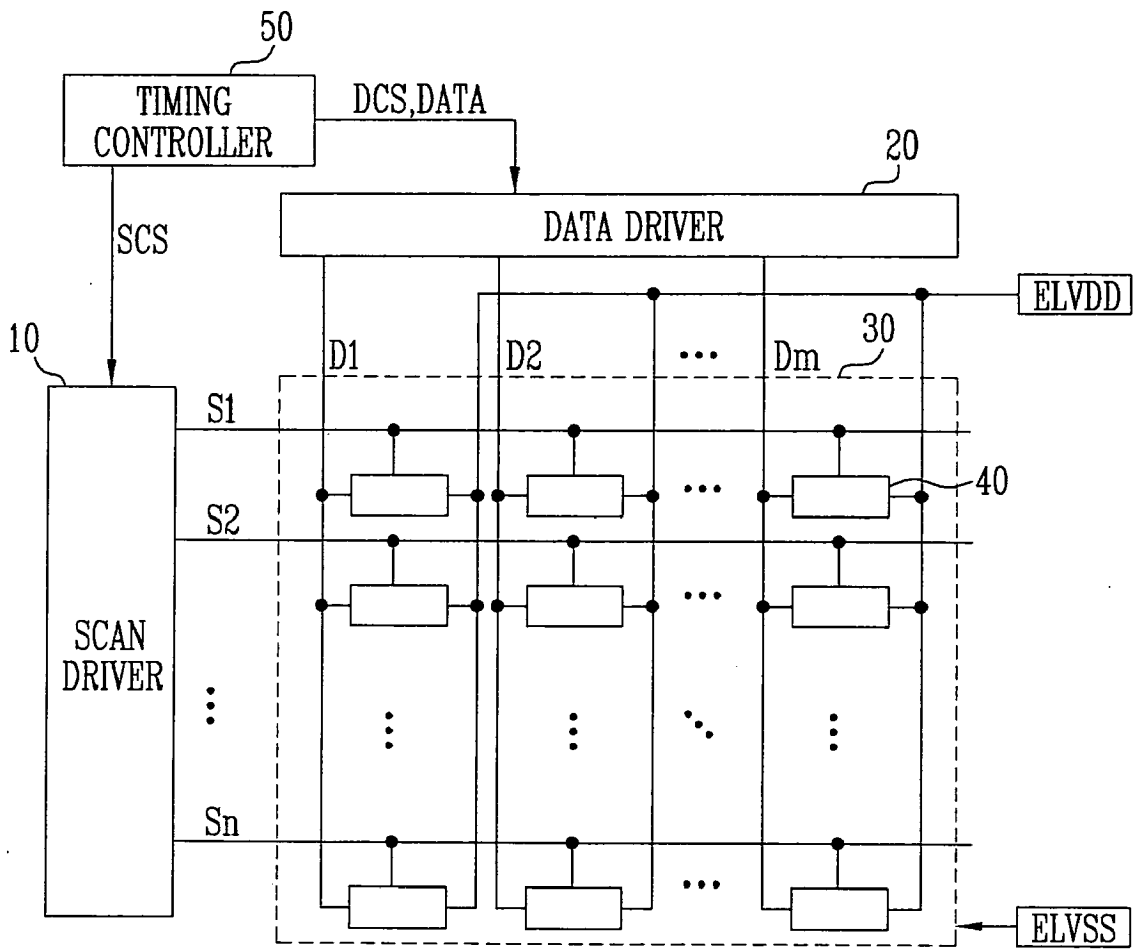

FIG. 2

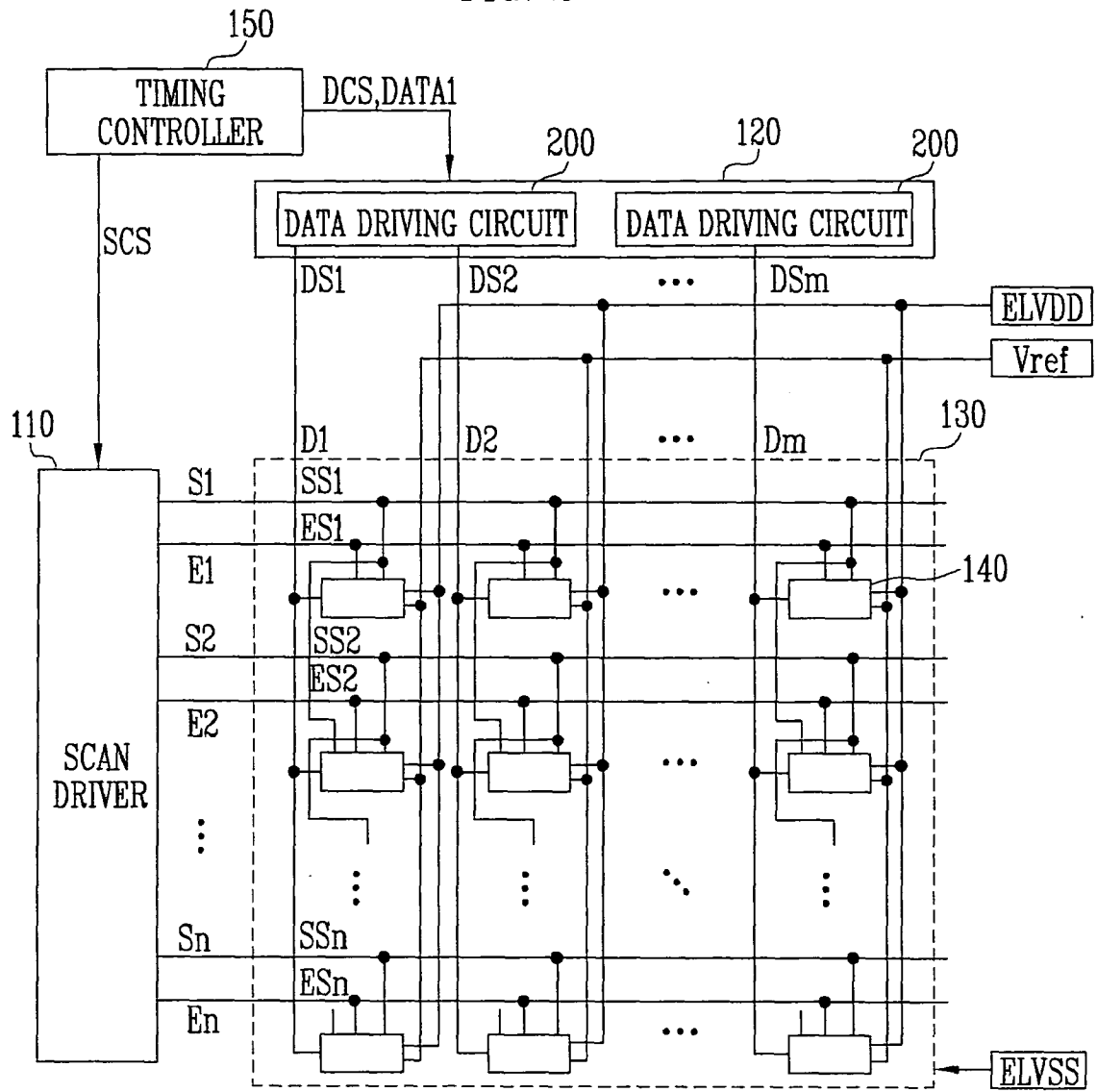

FIG. 3

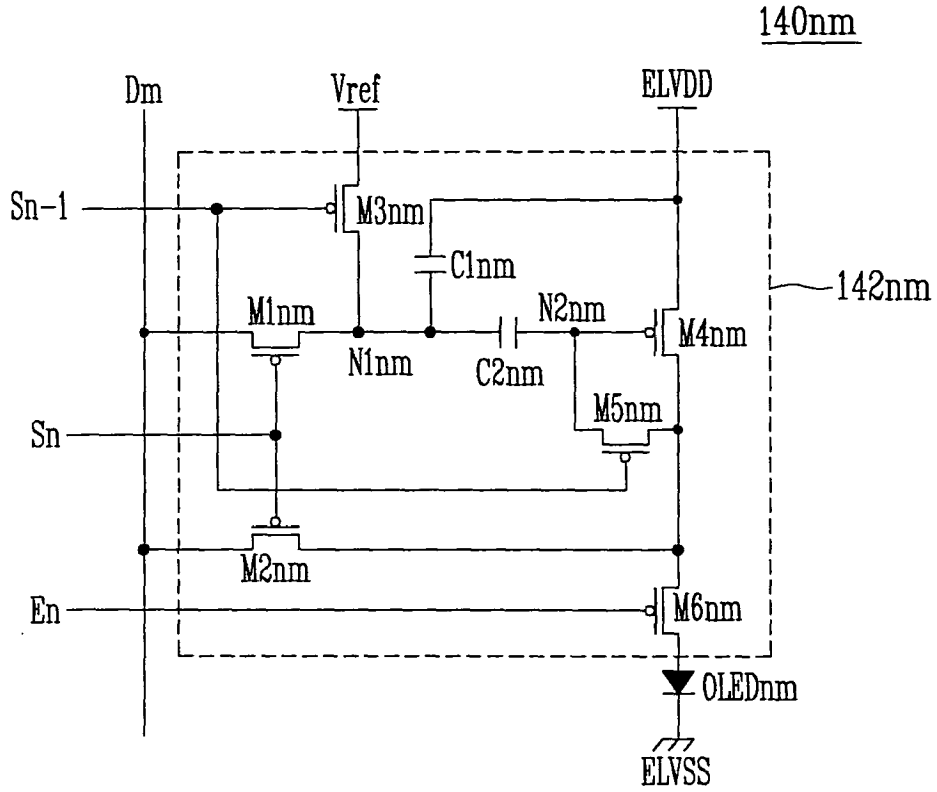

FIG. 4

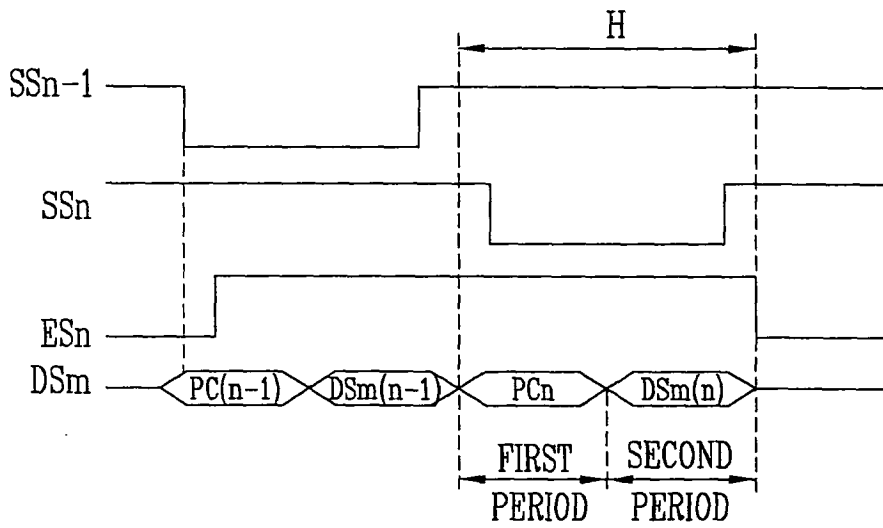

FIG. 5

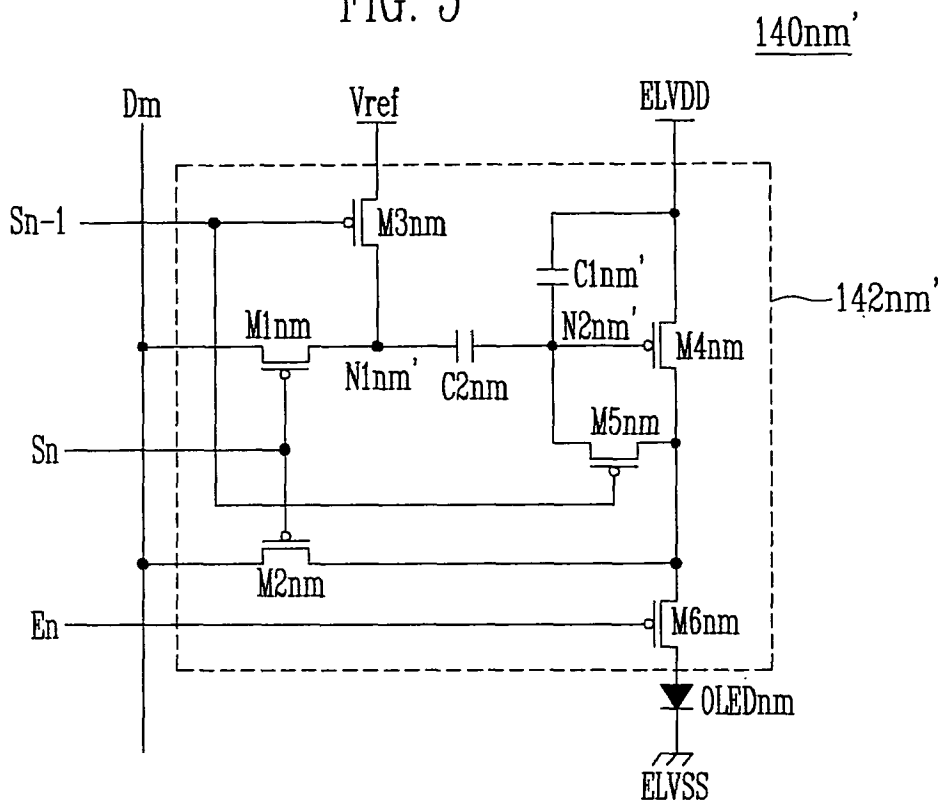

FIG. 6

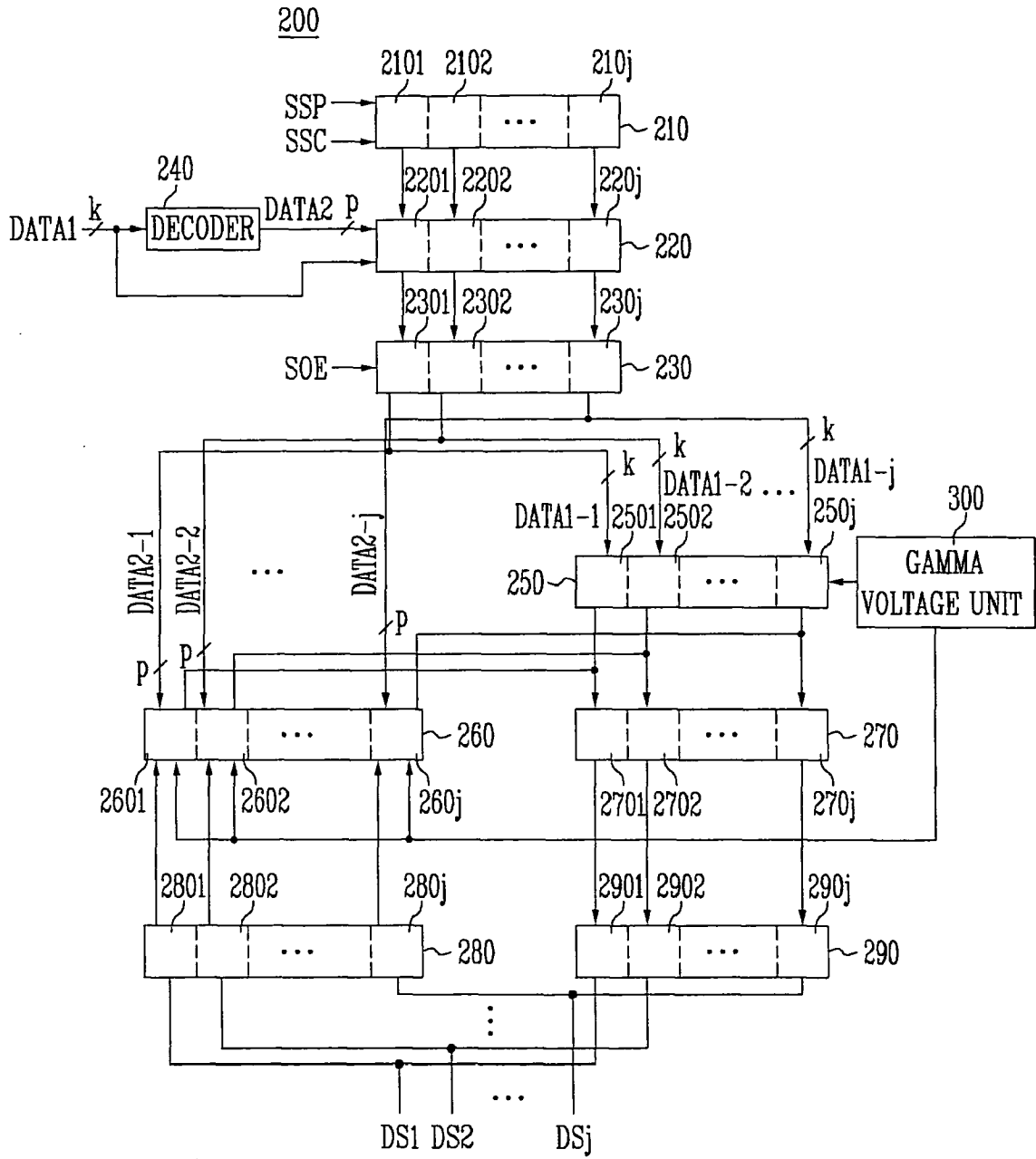

FIG. 7

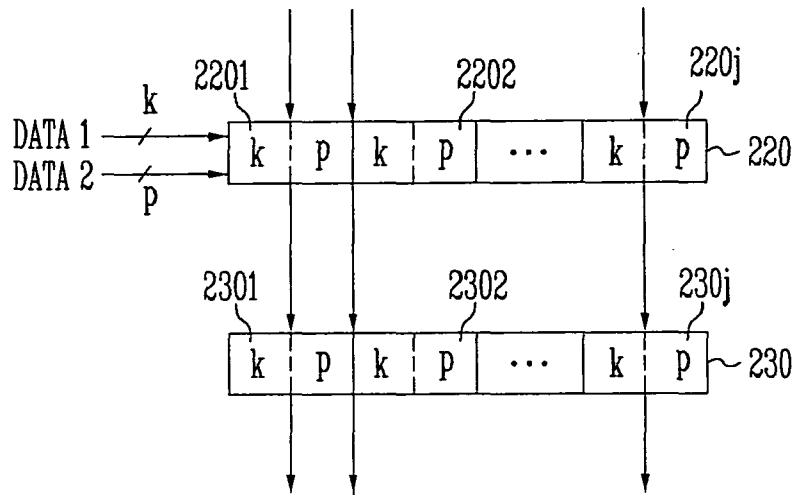

FIG. 8

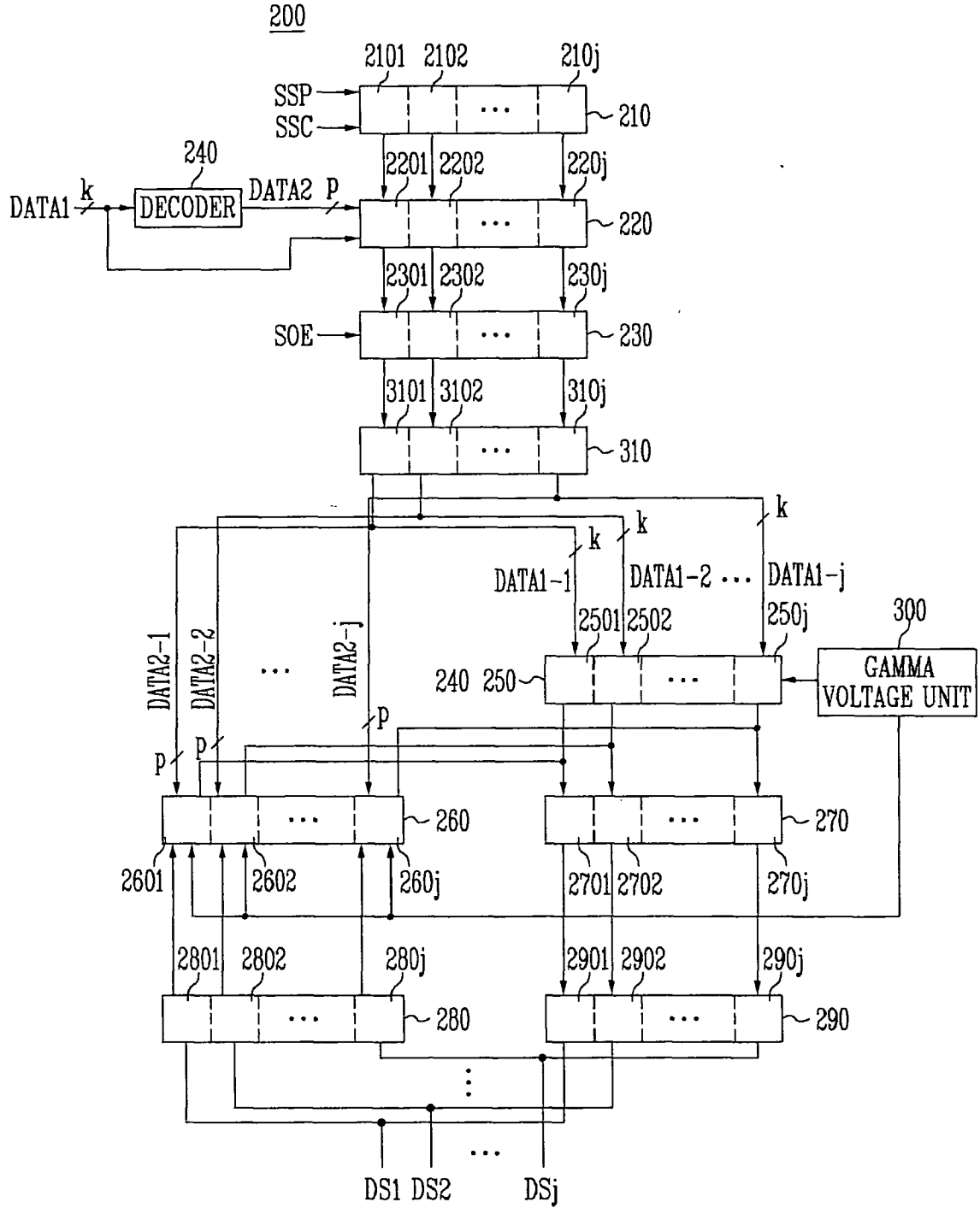

FIG. 9

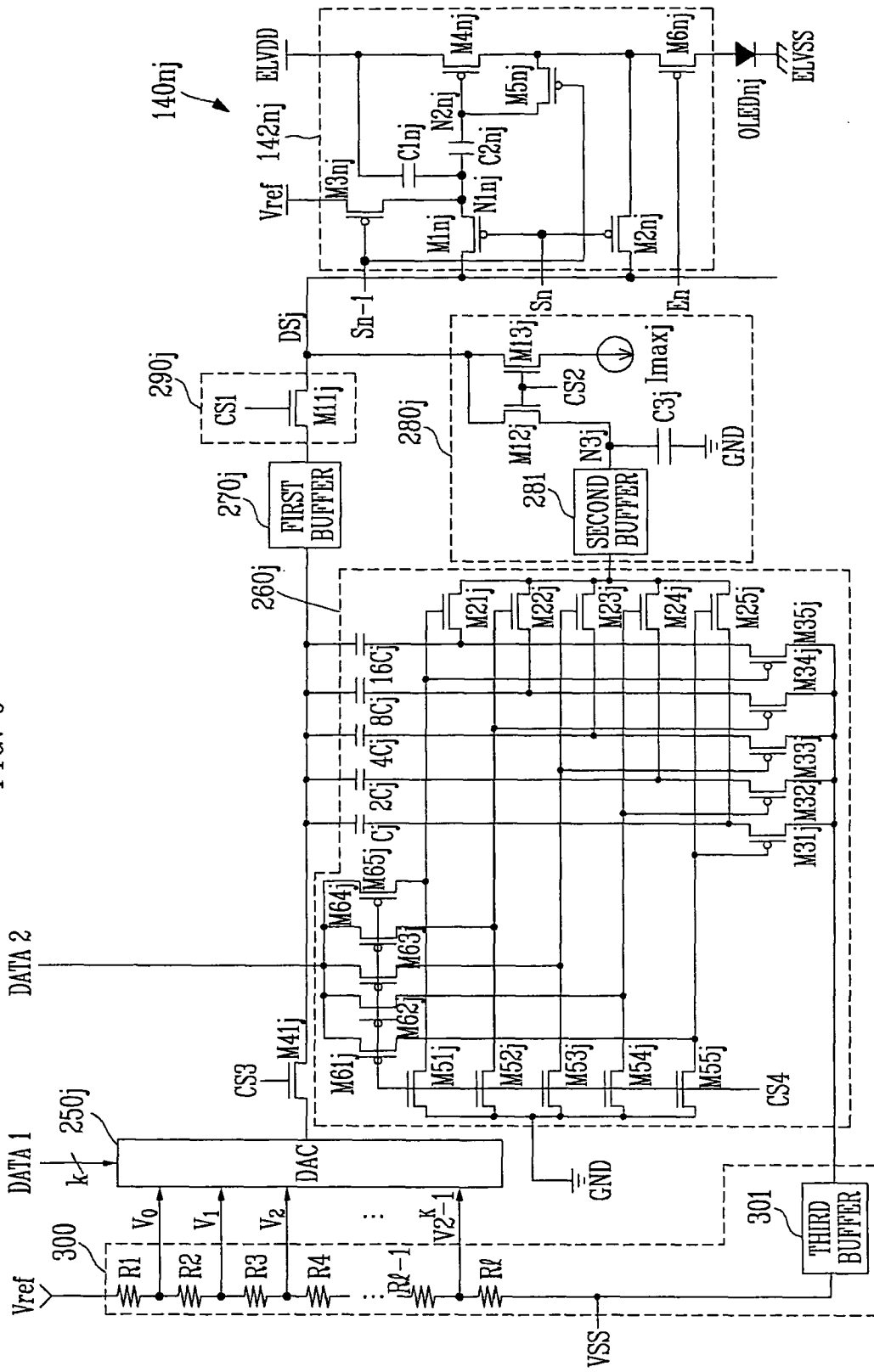

FIG. 10

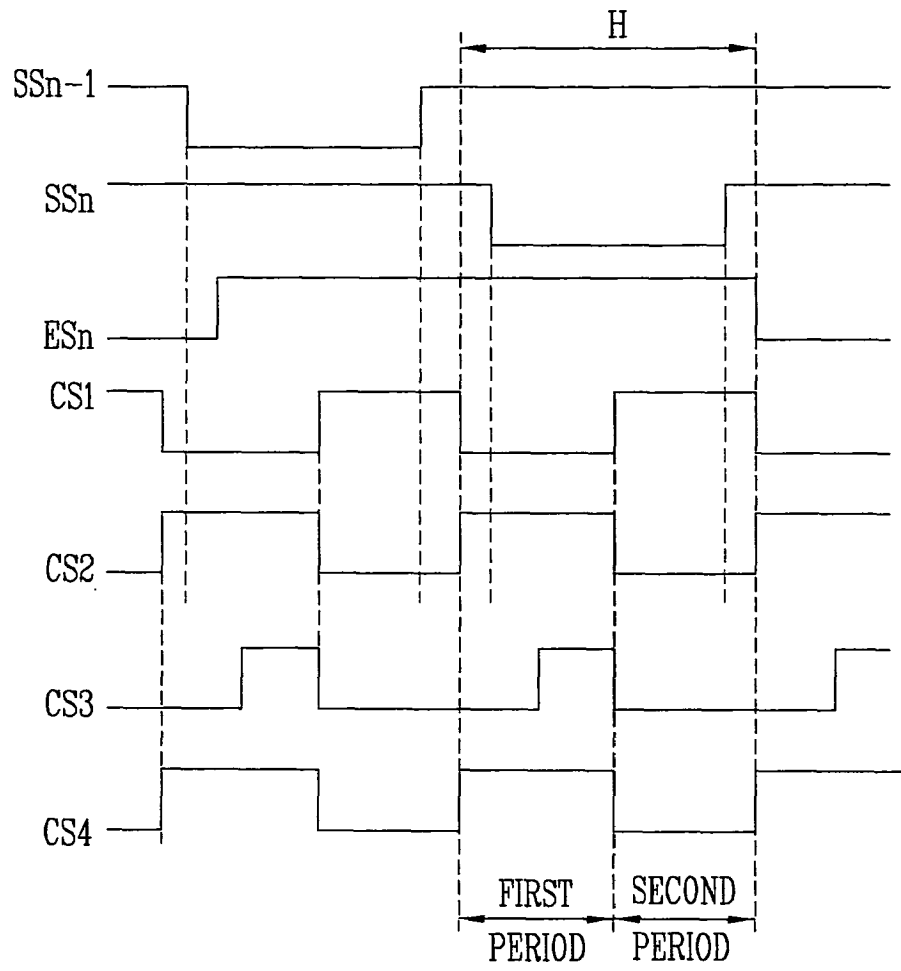

FIG. 11

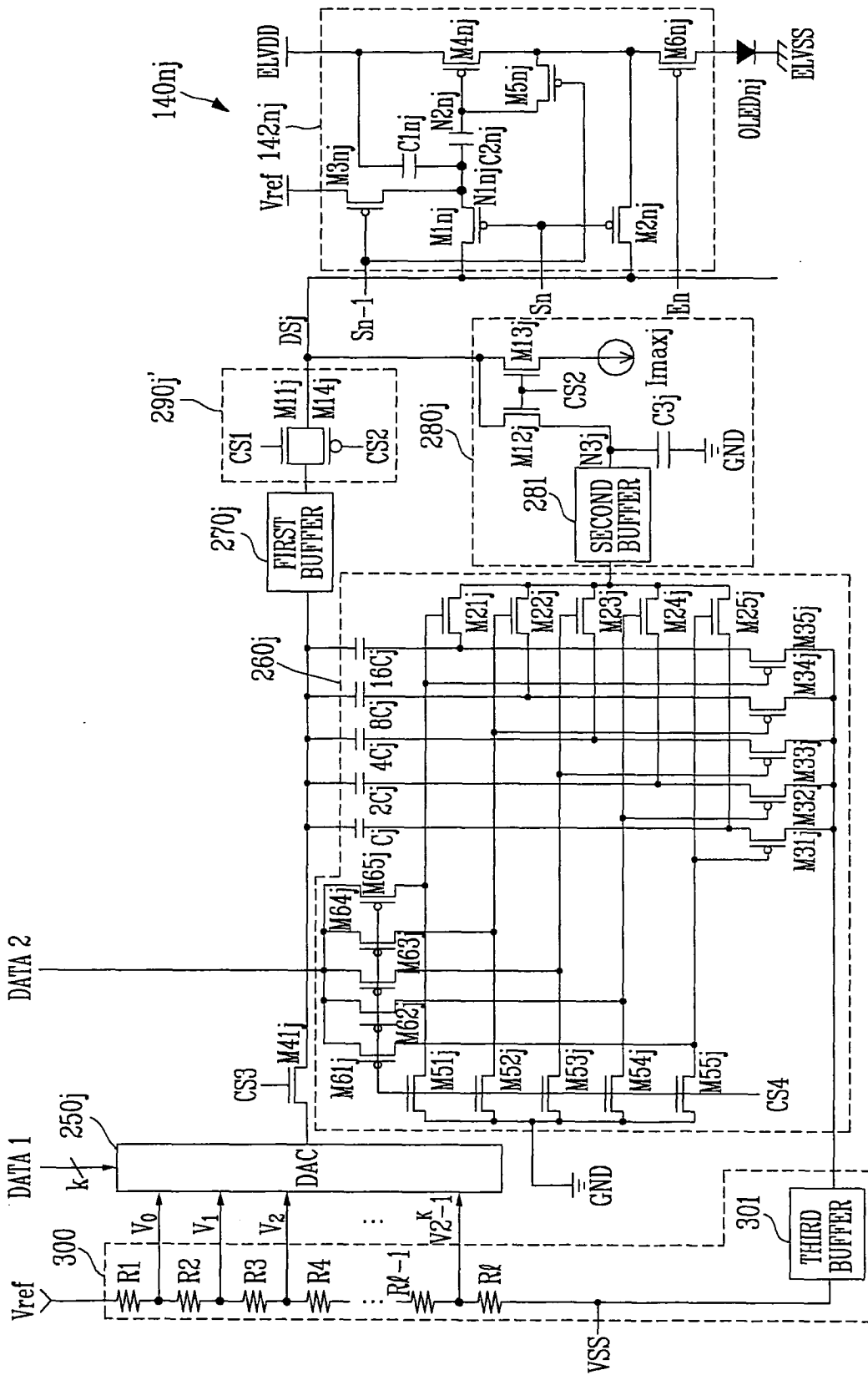
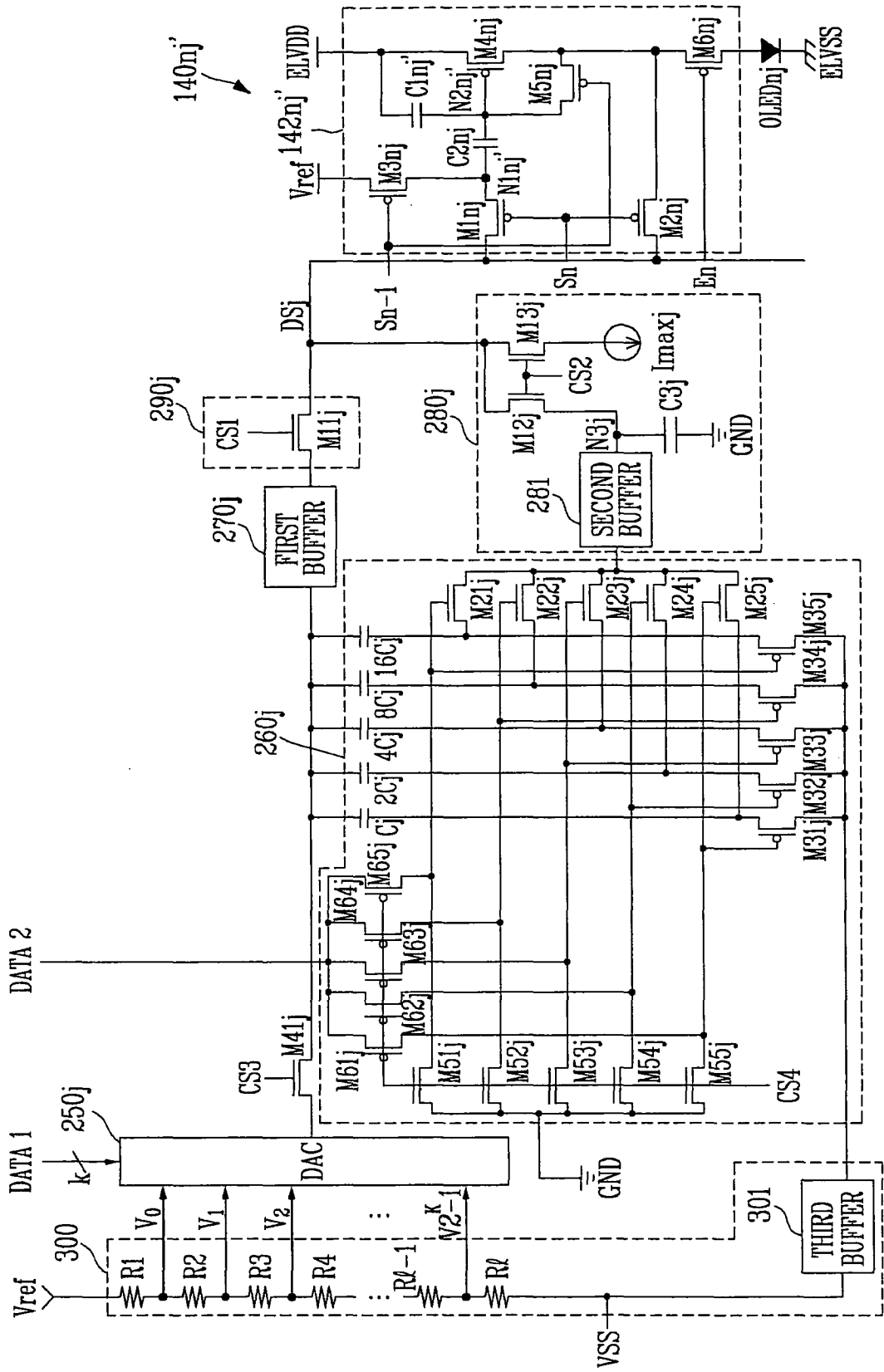

FIG. 12



专利名称(译)	数据驱动电路和使用其的有机发光二极管显示器		
公开(公告)号	EP1750247A2	公开(公告)日	2007-02-07
申请号	EP2006254022	申请日	2006-08-01
[标]申请(专利权)人(译)	三星斯笛爱股份有限公司 汉阳大学校产学协力团		
申请(专利权)人(译)	三星SDI CO., LTD. IUCF-HYU (产学合作基金会汉阳大学)		
当前申请(专利权)人(译)	三星DISPLAY CO., LTD.		
[标]发明人	CHUNG BO YONG SAMSUNG SDI CO LTD RYU DO HYUNG SAMSUNG SDI CO LTD KWON OH KYONG SAMSUNG SDI CO LTD		
发明人	CHUNG, BO YONG SAMSUNG SDI CO. LTD. RYU, DO HYUNG SAMSUNG SDI CO. LTD. KWON, OH KYONG SAMSUNG SDI CO. LTD.		
IPC分类号	G09G3/32		
CPC分类号	G09G3/3233 G09G3/3291 G09G2300/0819 G09G2300/0852 G09G2300/0861 G09G2310/0251 G09G2310/0262 G09G2310/027 G09G2320/043		
优先权	1020050070439 2005-08-01 KR		
其他公开文献	EP1750247A3		
外部链接	Espacenet		

摘要(译)

用于驱动显示器的像素以显示具有均匀亮度的图像的数据驱动电路可包括产生灰度级电压的伽马电压单元，数字 - 模拟转换器，其使用第一数据选择灰度级电压之一作为数据信号，使用所述第一数据生成第二数据的解码器，用于存储所述第一数据和所述第二数据的锁存器，在用于驱动所述像素的完整时段的第一部分时段期间从所述像素接收预定电流的电流源基于所选择的灰度级电压，使用第二数据控制数据信号的电压值的电压控制器和基于预定电流产生的补偿电压，以及在任何部分时段期间将数据信号提供给像素的开关单元。在第一个部分时期之后经过的完整时期。

