



(12) **EUROPEAN PATENT APPLICATION**

(43) Date of publication: **05.03.2014 Bulletin 2014/10** (51) Int Cl.: **G09G 3/32 (2006.01)**

(21) Application number: **12007398.6**

(22) Date of filing: **29.10.2012**

(84) Designated Contracting States:
AL AT BE BG CH CY CZ DE DK EE ES FI FR GB GR HR HU IE IS IT LI LT LU LV MC MK MT NL NO PL PT RO RS SE SI SK SM TR
 Designated Extension States:
BA ME

- **Shim, Jongsik**
Gyeonggi-do (KR)
- **Shin, Hongjae**
134-060 Seoul (KR)
- **Chang, Minkyu**
138-200 Seoul (KR)

(30) Priority: **30.08.2012 KR 20120095604**

(74) Representative: **Ter Meer Steinmeister & Partner**
Patentanwälte
Mauerkircherstrasse 45
81679 München (DE)

(71) Applicant: **LG Display Co., Ltd.**
Seoul 150-721 (KR)

(72) Inventors:
 • **Nam, Woojin**
411-751 Gyeonggi-do (KR)

(54) **Organic light emitting display and driving method thereof**

(57) An organic light emitting display comprises: a driving TFT (DT) comprising a gate connected to a node B, a drain connected to an input terminal of high-potential cell driving voltage, and a source connected to the organic light emitting diode through a node C; a first switching TFT (ST1) for switching the current path between a node A and the node B in response to a light emission control signal; a second switching TFT (ST2) for initializing the node C in response to an initialization signal; a third switching TFT (ST3) for initializing either the node A or the node B in response to the initialization signal; a fourth switching TFT (ST4) for switching the current path between a data line (14) and the node B in response to a scan signal; a compensation capacitor (C_{gss}) connected between the node B and the node C.

control signal; a second switching TFT (ST2) for initializing the node C in response to an initialization signal; a third switching TFT (ST3) for initializing either the node A or the node B in response to the initialization signal; a fourth switching TFT (ST4) for switching the current path between a data line (14) and the node B in response to a scan signal; a compensation capacitor (C_{gss}) connected between the node B and the node C.

FIG. 3

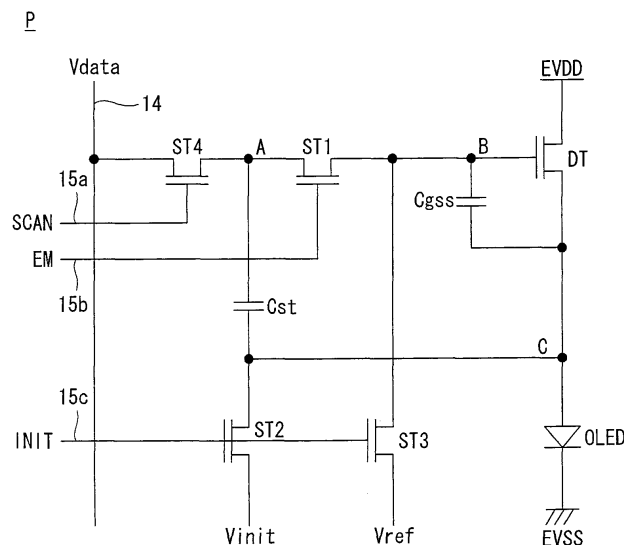

Description

[0001] This application claims the benefit of Korean Patent Application NO. 10-2012-0095604 filed on August 30, 2012, which is incorporated herein by reference for all purposes as if fully set forth herein.

BACKGROUND OF THE INVENTION

Field of the Invention

[0002] This document relates to an active matrix type organic light emitting display and a driving method thereof.

Discussion of the Related Art

[0003] An active matrix type organic light emitting display includes a self-luminous organic light emitting diode (hereinafter, referred to as "OLED"), and is advantageous in that it has high response speed, luminous efficiency, and luminance, and a large viewing angle.

[0004] An OLED, which is a self-luminous element, has the structure as shown in FIG. 1. The OLED includes an anode, a cathode, and an organic compound layer HIL, HTL, EML, ETL, EIL formed between the anode and the cathode. The organic compound layer includes a hole injection layer HIL, a hole transport layer HTL, an emission layer EML, an electron transport layer ETL and an electron injection layer EIL. If drive voltages are applied to the anode electrode and the cathode electrode, holes within the hole injection layer HTL and electrons within the electron transport layer ETL respectively move to the emission layer EML to form excitons. As a result, the emission layer EML emits a visible ray.

[0005] The organic light emitting display includes pixels each including an OLED which area arranged in a matrix form, and controls the luminance of the pixels according to the gray scale of video data. Each pixel includes a driving TFT (thin film transistor) for controlling the driving current flowing through the OLED in accordance with a gate-source voltage, a capacitor for keeping a gate potential of the driving TFT constant during a frame, and a switching TFT for storing a data voltage in the capacitor in response to a gate signal. The luminance of a pixel is proportional to the magnitude of the driving current that flows through the OLED.

[0006] The organic light emitting display is disadvantageous in that the driving TFTs of the pixels have different threshold voltages depending on where they are formed, due to a process deviation or the like, or the electrical properties of the driving TFTs are deteriorated due to a gate-bias stress which occurs with the elapse of driving time. To solve this problem, Korean Laid-Open Patent Publication No. 10-2005-0122699 discloses a pixel circuit of an organic light emitting display which detects, as the threshold voltage of a driving TFT, a gate-source voltage at which a drain-source current becomes suffi-

ciently small by diode-connecting the driving TFT, and compensates a data voltage by the detected threshold voltage. The pixel circuit uses a light emission control TFT serially connected between the driving TFT and an OLED in order to turn off light emission of the OLED upon detecting the threshold voltage of the driving TFT.

[0007] However, the conventional pixel circuit of an organic light emitting display is problematic in that its capability of compensating for the threshold voltage of the driving TFT is low and some TFTs show low reliability due to the following reasons.

[0008] First, when detecting the threshold voltage of a driving TFT of a diode structure, a gate-drain voltage becomes "0V", and thus a minimum threshold voltage (for n-type) or maximum detectable threshold voltage (for p-type) is "0V". Therefore, according to a conventional method for detecting the threshold voltage of a driving TFT by diode connection, a pixel circuit using an n-type TFT can detect the threshold voltage of the driving TFT only when the threshold voltage of the driving TFT has a positive value, and a pixel circuit using a p-type TFT can detect the threshold voltage of the driving TFT only when the threshold voltage of the driving TFT has a negative value. In other words, a conventional method for compensating a threshold voltage cannot be applied if the threshold voltage of the driving TFT in the pixel circuit using a p-type TFT has a negative value, and also cannot be applied if the threshold voltage of the driving TFT in the pixel circuit using an n-type TFT has a positive value.

[0009] Second, a parasitic capacitance exists between a TFT of a pixel circuit and a signal line. The parasitic capacitance causes a kick-back voltage when a gate signal applied to the TFT is turned off. If the kick-back voltage is high, a detected threshold voltage cannot be properly maintained but distorted, thus decreasing the accuracy of compensation. To increase the accuracy of threshold voltage compensation, the gate and source voltages of the driving TFT need to be increased further when detecting a threshold voltage, by taking distortion in subsequent steps into consideration. However, the conventional method for threshold voltage compensation cannot improve the accuracy of compensation because a fixed potential is applied to the gate of the driving TFT.

[0010] Third, the light emission control TFT serially connected between the driving TFT and the OLED is turned off in a period during which threshold voltage sensing and data programming are performed, and turned on in a period during which light emission occurs. Assuming that the period during which threshold voltage sensing and data programming are performed is a first period, and the period during which light emission occurs is a second period, a proportion that the second period occupies in one frame is much larger than that of the first period. Since the light emission control TFT in the pixel circuit is kept turned on during the entire emission period, the reliability of the light emission control TFT is lowered due to a deterioration caused by a gate-bias stress.

SUMMARY

[0011] Accordingly, it is an object of the present invention to provide an organic light emitting display and a driving method thereof which increase the capability of compensating for the threshold voltage of a driving TFT and improve the reliability of TFTs in the pixel circuit.

[0012] To accomplish the above aspect, according to an exemplary embodiment of the present invention, there is provided an organic light emitting display comprising: an organic light emitting diode; a driving TFT comprising a gate connected to a node B, a drain connected to an input terminal of high-potential cell driving voltage, and a source connected to the organic light emitting diode through a node C, and for controlling the current applied to the organic light emitting diode; a first switching TFT for switching the current path between a node A and the node B in response to a light emission control signal; a second switching TFT for initializing the node C to an initialization voltage in response to an initialization signal; a third switching TFT for initializing either the node A or the node B to a reference voltage higher than the initialization voltage in response to the initialization signal; a fourth switching TFT for switching the current path between a data line and the node B in response to a scan signal; a compensation capacitor connected between the node B and the node C; and a storage capacitor connected between node A and node C.

[0013] To accomplish the above aspect, a driving method of an organic light emitting display comprising a driving TFT comprising a gate connected to a node B, a drain connected to an input terminal of high-potential cell driving voltage, and a source connected to the organic light emitting diode through a node C, and for controlling the current applied to the organic light emitting diode, the method comprising: initializing the node C to an initialization voltage in response to an initialization signal, and initializing the node B to a reference voltage higher than the initialization voltage in response to the initialization signal and a light emission control signal; stopping the supply of the initialization voltage and allowing the node B to float, and then detecting and storing the threshold voltage of the driving TFT by using a compensation capacitor connected between the node B and the node C; applying a data voltage to a node A connected to a storage capacitor in response to a scan signal; and transmitting the data voltage of the node A to the node B in response to the light emission control signal to compensate for the driving current applied to the organic light emitting diode, regardless of the threshold voltage, and causing the organic light emitting diode to emit light.

BRIEF DESCRIPTION OF THE DRAWINGS

[0014] The accompanying drawings, which are included to provide a further understanding of the invention and are incorporated in and constitute a part of this specification, illustrate embodiments of the invention and to-

gether with the description serve to explain the principles of the invention.

[0015] In the drawings:

[0016] FIG. 1 is a view showing an organic light emitting diode and the principle of light emission thereof;

[0017] FIG. 2 shows an organic light emitting display according to an exemplary embodiment of the present invention;

[0018] FIG. 3 shows an example of the pixel P of FIG. 2;

[0019] FIG. 4 is a waveform diagram showing signals applied to the pixel of FIG. 3, potential changes of nodes A, B, and C responsive to these signals, and changes in the current flowing through the driving TFT and the OLED;

[0020] FIG. 5a is an equivalent circuit diagram of the pixel corresponding to an initialization period;

[0021] FIG. 5b is an equivalent circuit diagram of the pixel corresponding to a sensing period;

[0022] FIG. 5c is an equivalent circuit diagram of the pixel corresponding to a programming period;

[0023] FIG. 5d is an equivalent circuit diagram of the pixel corresponding to a first emission period;

[0024] FIG. 5e is an equivalent circuit diagram of the pixel corresponding to a second emission period;

[0025] FIG. 6 shows a design method of a driving TFT for improving the threshold voltage compensation capability;

[0026] FIG. 7 shows another example of the pixel P of FIG. 2; and

[0027] FIG. 8 shows a driving waveform of a gate signal suggested in the present invention, as compared to the conventional art;

[0028] FIG. 9 shows the progress of threshold voltage degradation in accordance with the on duty of the gate signal; and

[0029] FIG. 10 shows the result of simulation of the threshold voltage compensation performance of the pixel suggested in the present invention.

DETAILED DESCRIPTION

[0030] Hereinafter, an exemplary embodiment of the present invention will be described with reference to FIGS. 2 to 10.

[0031] FIG. 2 shows an organic light emitting display according to an exemplary embodiment of the present invention.

[0032] Referring to FIG. 2, the organic light emitting display according to the exemplary embodiment of the present invention comprises a display panel 10 having pixels P arranged in a matrix form, a data driving circuit 12 for driving data lines 14, a gate driving circuit 13 for driving gate line portions 15, and a timing controller for controlling the driving timings of the data and gate driving circuits 12 and 13.

[0033] A plurality of data lines 14 and a plurality of gate line portions 15 cross each other on the display panel 10, and pixels P are disposed in a matrix form at crossing

regions of the data lines 14 and the gate line portions 15. Each of the gate line portions 15 comprises a scan line 15a, an emission line 15b, and an initialization line 15c. Each pixel P is connected to a data line 14 and the three signal lines 15a, 15b, and 15c constituting a gate line portion 15. The pixels P are supplied with high-potential and low-potential cell driving voltages EVDD and EVSS, a reference voltage Vref, and an initialization voltage Vinit. The reference voltage Vref and the initialization voltage Vinit may be set lower than the low-potential cell driving voltage EVSS. The reference voltage Vref is set higher than the initialization voltage Vinit; especially, the difference between the reference voltage Vref and the initialization voltage Vinit may be set higher than the threshold voltage of a driving TFT. Each of the pixels P comprises an OLED, a driving TFT, four switching TFTs, and two capacitors.

[0034] The pixel P of the present invention detects the threshold voltage of the driving voltage according to a source-follower method, instead of a conventional diode connection method. In the source-follower method, a compensation capacitor is connected between the gate and source of the driving TFT, and the source voltage of the driving TFT follows the gate voltage upon detecting the threshold voltage. Moreover, since the drain of the driving TFT is separated from the gate and supplied with the high-potential cell driving voltage EVDD, this source-follower method makes it possible to detect a negative threshold voltage value, as well as a positive threshold voltage value. The pixel P of the present invention allows the gate of the driving TFT to float upon sensing the threshold voltage of the driving TFT, and improves the threshold voltage compensation capability by using the compensation capacitor connected between the gate and source of the driving TFT and a parasitic capacitor of the driving TFT. By minimizing the on-duty of a light emission control signal applied to the pixel P of the present invention, any deterioration of the switching TFTs to be switched on in accordance with a light emission control signal can be minimized. A detailed configuration of the pixel P of the present invention will be described later in detail with reference to FIG. 3.

[0035] The TFTs constituting the pixel P may be implemented as oxide TFTs each including an oxide semiconductor layer. When electron mobility, process deviation, etc are all considered, the oxide TFTs are advantageous for a large-sized display panel 10. However, the present invention is not limited thereto, but the semiconductor layers of the TFTs may be formed of amorphous silicon, polysilicon, etc. Although the following detailed description is made with respect to an n-type TFT, the present invention is also applicable to a p-type TFT.

[0036] The timing controller 11 re-aligns digital video data RGB input from an external system board in accordance with the resolution of the display panel 10 to supply to the data driving circuit 12. And, the timing controller 11 generates a data timing control signal DDC for controlling an operating timing of the data driving circuit 12

and a gate timing control signal GDC for controlling an operating timing of the gate driving circuit 13 based on timing signals including a vertical synchronization signal Vsync, a horizontal synchronization signal Hsync, a dot clock signal DCL, and a data enable signal DE.

[0037] The data driving circuit 12 converts the digital video data RGB input from the timing controller 11 based on the data control signal DDC into an analog data voltage and supplies it to the data lines 14.

[0038] The gate driving circuit 13 generates a scan signal, a light emission signal, and an initialization signal based on the gate control signal GDC. The gate driving circuit 13 supplies scan signals to the scan lines 15a in a line-sequential manner, supplies light emission control signals to the emission lines 15b in a line-sequential manner, and supplies initialization signals to the initialization lines 15c in a line-sequential manner. The gate driving circuit 13 may be formed directly on the display panel 10 in a GIP (Gate-driver In Panel) manner.

[0039] FIG. 3 shows an example of the pixel P of FIG. 2.

[0040] Referring to FIG. 3, the pixel P according to one exemplary embodiment of the present invention comprises an OLED, a driving TFT (DT), first to fourth TFTs (ST1 to ST4), a compensation capacitor Cgss, and a storage capacitor Cst.

[0041] The OLED emits light by the driving current supplied from the driving TFT (DT). As shown in FIG. 1, multiple organic compound layers are formed between the anode and cathode of the OLED. The organic compound layers comprise a hole injection layer HIL, a hole transport layer a hole transport layer HTL, an emission layer EML, an electron transport layer ETL, and an electron injection layer EIL. The anode of the OLED is connected to a source electrode of the driving TFT (DT), and the cathode thereof is connected to an input terminal of low-potential cell driving voltage EVSS.

[0042] The driving TFT (DT) controls the driving current applied to the OLED by its gate-source voltage. The gate electrode of the driving TFT (DT) is connected to node B, the drain electrode thereof is connected to an input terminal of high-potential cell driving voltage EVDD, and the source electrode thereof is connected to node C.

[0043] The first switching TFT (ST1) switches the current path between node A and node B in response to a light emission control signal EM. The first switching TT (ST1) is turned to transmit the data voltage Vdata stored in node A to node B. The gate electrode of the first switching TFT (ST1) is connected to the emission line 15b, its drain electrode is connected to node A, and its source electrode is connected to node B.

[0044] The second switching TFT (ST2) switches the current path between an input terminal of initialization voltage Vinit and node C. The second switching TFT (ST2) is turned on to supply an initialization voltage Vinit to node C. The gate electrode of the second switching TFT (ST2) is connected to the initialization line 15c, its drain electrode is connected to the input terminal of initialization voltage Vinit, and its source electrode is con-

nected to node C.

[0045] The third switching TFT (ST3) switches the current path between an input terminal of reference voltage V_{ref} and node B in response to an initialization signal INIT. The third switching TFT (ST3) is turned on to supply a reference voltage V_{ref} to node B. The gate electrode of the third switching TFT (ST3) is connected to the initialization line 15c, its drain electrode is connected to the input terminal of reference voltage V_{ref} , and its source electrode is connected to node B.

[0046] The fourth switching TFT (ST4) switches the current path between the data line 14 and node A in response to a scan signal SCAN. The fourth switching TFT (ST4) is turned on to supply a data voltage V_{data} to node A. The gate electrode of the fourth switching TFT is connected to the scan lines 15a, its drain electrode is connected to the data line 14, and its source electrode is connected to node A.

[0047] The compensation capacitor C_{gss} is connected between node B and node C. The compensation capacitor C_{gss} enables the source-follower method upon detecting the threshold voltage of the driving TFT (DT).

[0048] The storage capacitor C_{st} is connected between node A and node B. The storage capacitor C_{st} functions to store the data voltage V_{data} input into node A and then transmit it to node B.

[0049] FIG. 4 is a waveform diagram showing signals EM, SCAN, INIT, and DATA applied to the pixel P of FIG. 3, potential changes of nodes A, B, and C responsive to these signals, and changes in the current flowing through the driving TFT (DT) and the OLED. FIGS. 5a to 5e show equivalent circuits of the pixel P in an initialization period T_i , a sensing period T_s , a programming period T_p , and first and second emission periods T_{e1} and T_{e2} , respectively. In FIGS. 5a to 5e, the activation of the elements is indicated by solid lines, and the deactivation of the elements is indicated by dotted lines.

[0050] Referring to FIG. 4, the operation of the pixel P according to the present invention is divided into an initialization period T_i for initializing nodes A, B, and C to a specific voltage, a sensing period T_s for detecting and storing the threshold voltage of the driving TFT (DT), a programming period T_p for applying a data voltage V_{data} , and an emission period T_e for compensating the driving current applied to the OLED using the threshold voltage and the data voltage V_{data} , regardless of the threshold voltage. The emission period T_e is subdivided into first and second emission periods T_{e1} and T_{e2} .

[0051] Referring to FIG. 4 and FIG. 5a, the second switching TFT (ST2) is turned on in response to an initialization signal INIT of ON level in the initialization period T_i to supply an initialization voltage V_{init} to node C, and the third switching TFT (ST3) is turned on in response to the initialization signal INIT of ON level to supply a reference voltage V_{ref} to node B. The first switching TFT (ST1) is turned on in response to a light emission control signal EM of ON level to supply the reference voltage V_{ref} to node A. The fourth switching TFT (ST4) is turned

off in response to a scan signal SCAN of OFF level. The reference voltage V_{ref} is set higher than the initialization voltage V_{init} to make the driving TFT (DT) conductive. Also, the initialization voltage V_{init} is set to an appropriate low value to prevent the light emission of the OLED in the other periods T_i , T_s , and T_p than the emission period T_e . For example, if the high-potential cell driving voltage EVDD is set to 20 V, and the low-potential cell driving voltage EVSS is set to 0 V, the reference voltage V_{ref} and the initialization voltage V_{init} may be set to -1 V and -5 V, respectively.

[0052] In the initialization period T_i , nodes A and B are charged with the reference voltage V_{ref} , and node C is charged with the initialization voltage V_{init} . During the initialization period T_i , the gate-source voltage of the driving TFT (DT) is higher than the threshold voltage. Therefore, the driving TFT (DT) is turned on, and the current I_{dt} flowing through the driving TFT (DT) has an appropriate initialization value.

[0053] Referring to FIG. 4 and FIG. 5b, in the sensing period T_s , the first switching TFT (ST1) is turned off by the light emission control signal EM of OFF level, the second and third switching TFTs (ST2 and ST3) are turned off by the initialization signal INIT of OFF level, and the fourth switching TFT (ST4) is turned off by the scan signal SCAN of OFF level.

[0054] In the sensing period T_s , the voltage of node C rises as the supply of the initialization voltage V_{init} is stopped, and as a result the current I_{dt} flowing through the driving TFT (DT) gradually decreases. When the gate-source voltage of the driving TFT (DT) reaches the threshold voltage V_{th} , the driving TFT (DT) is turned off. At this point, the threshold voltage V_{th} of the driving TFT (DT) is detected in the source-follower method, and reflected on the potential of node C. In the present invention, even a threshold voltage V_{th} having a positive value, as well as a negative value, can be detected according to the source-follower method, regardless of whether the driving TFT is an n-type TFT or p-type TFT. The potential of node C rises from the initialization voltage V_{init} up to " $(V_{ref}-V_{th})+\alpha$ " (hereinafter, referred to as an "intermediate source voltage"). In the sensing period T_s , node B is allowed to float. In this case, when the potential of node C rises to the "intermediate source voltage", the potential of node B also rises to " $V_{ref}+\alpha$ " (hereinafter, referred to as an "intermediate gate voltage") due to a capacitor coupling effect. " α " included in the "intermediate source voltage" and "intermediate gate voltage" is an amplification compensation factor, which increases in proportion to the threshold voltage of the driving TFT (DT). An additional increase in the potentials of both nodes B and C plays an important role in improving the accuracy of compensation of the threshold voltage V_{th} in a subsequent emission period T_e . " α " on which the threshold voltage compensation capability depends on is a design value which is set in consideration of distortion of threshold voltage compensation caused by a kick-back voltage. The value of " α " can be adjusted by a parasitic

capacitor of the driving TFT (DT) and the compensation capacitor C_{gss} . By properly adjusting the value of " α ", the threshold voltage V_{th} can be efficiently compensated for without being affected by the parasitic capacitor of the driving TFT (DT). This will be described later in FIG. 6. The threshold voltage V_{th} of the driving TFT (DT) detected in the sensing period T_s is stored and maintained in node C by the compensation capacitor C_{gss} . The threshold voltage V_{th} of the driving TFT (DT) stored and maintained in node C may have a negative voltage value of " $-V_{th}$ ".

[0055] Referring to FIG. 4 and FIG. 5c, in the programming period T_p , the fourth switching TFT (ST4) is turned on by a scan signal SCAN of ON level to supply a data voltage V_{data} to node A. The first switching TFT (ST1) is turned off by the light emission signal EM of OFF level, and the second and third switching TFTs (ST2 and ST3) are turned off by the initialization signal INIT of OFF level. In the programming period T_p , nodes B and C are separated from node A by a TFT or capacitor, and therefore maintains nearly the same potential as that in the sensing period T_s (although the potential is slightly changed due to the capacitor coupling effect, but almost ignorable).

[0056] Referring to FIG. 4 and FIG. 5d, in the first emission period T_{e1} , the first switching TFT (ST1) is turned on by the light emission period of ON level to transmit the data voltage V_{data} charged in node A to node B. The second and third switching TFTs (ST2 and ST3) are turned off by the initialization signal INIT of OFF level, and the fourth switching TFT (ST4) is turned off by the scan signal SCAN of OFF level.

[0057] In the first emission period T_{e1} , the driving TFT (DT) is turned on by the data voltage V_{data} transmitted to node B. The current I_{dt} flowing through the driving TFT (DT) causes the potential of node C to increase to " V_{oled} " by which the OLED is made conductive, and as a result, the OLED is turned on. When the OLED is turned on, the currents I_{ddt} and I_{oled} flowing through the OLED and the driving TFT (DT) become equal. When the first driving current I_{olde1} flows through the OLED, the potential of node C is boosted to " V_{oled} " (hereinafter, referred to as a "first final source voltage"), and the potentials of nodes A and B are all boosted to " $a \cdot V_{th} + b \cdot V_{data} + V_{oled} + C$ " (hereinafter, referred to as a "first final gate voltage"). In the first final gate voltage, " a " multiplied by the threshold voltage V_{th} is a constant affected by parasitic capacitors (C_{gs} and C_{gd} of FIG. 6) of the driving TFT (DT), which is ideally "1", but actually "less than 1" because of the parasitic capacitors. In this case, in the equation of the first driving current I_{olde1} , the factors of the threshold voltage V_{th} are not completely compensated for, as shown in $\beta/2 (V_{gs} - V_{th})^2 = \beta/2 (a \cdot V_{th} + b \cdot V_{data} + C - V_{th})^2$, whereby the threshold voltage compensation capability is lowered. To completely compensate for the threshold voltage, " a " multiplied by the threshold voltage V_{th} has to be 1. In the present invention, " a " multiplied by the threshold voltage V_{th} becomes 1 by properly selecting the amplification compensation factor " α " included in the

intermediate source voltage" and the intermediate gate voltage". By this, the present invention can improve the threshold voltage compensation capability. In the above equation, " β " denotes a constant determined by the mobility of the driving TFT (DT), a parasitic capacitance, and a channel size, " V_{gs} " denotes the gate-source voltage of the driving TFT (DT), " b " denotes a distribution coefficient caused by the compensation capacitor C_{gss} , the storage capacitor C_{st} , and the parasitic capacitor of the driving TFT (DT), and " C " denotes a constant for simplifying the equation of the first final source voltage.

[0058] Referring to FIG. 4 and FIG. 5e, in the second emission period T_{e2} , the first switching TFT (ST1) is turned off by the light emission control signal EM of OFF level, the second and third switching TFTs (ST2 and ST3) are turned off by the initialization signal INIT of OFF level, and the fourth switching TFT (ST4) is turned off by the scan signal SCAN of off level.

[0059] The second emission period T_{e2} is a period required to prevent deterioration of the first switching TFT (ST1) to which the light emission control signal EM is applied. To this end, the light emission control signal EM is maintained at the OFF level during the second emission period T_{e2} , unlike the conventional art. Since it is maintained at the OFF level in the second emission period T_{e2} , the light emission control signal EM has a first pulse P1 corresponding to the initialization period T_i and a second pulse P2 corresponding to the first emission period T_{e1} . A proportion that the second emission period T_{e2} occupies in one frame is much larger than those of the other periods T_i , T_s , T_p , and T_{e1} . Since the first switching TFT (ST1) is kept turned off in the second emission period T_{e2} , it is free of any degradation caused by a gate bias stress.

[0060] When the first switching TFT (ST1) is turned off in the second emission period T_{e2} , the potentials of nodes B and C (needless to say, the potential of node A also changes) are reduced to a second final gate voltage " X " and a second final source voltage " Y ", respectively. At this point, compensation of the driving TFT (DT) is maintained the same as that in the first emission period T_{e1} , and the currents I_{dt} and I_{oled} flowing through the OLED and the driving TFT (DT) become equal, that is, the second driving current I_{oled2} . The gray scale of the pixel is determined by integral values of the first and second driving currents I_{oled1} and I_{oled2} .

[0061] FIG. 6 shows a design method of a driving TFT (DT) for improving the threshold voltage compensation capability.

[0062] Referring to FIG. 6, a first parasitic capacitor C_{gs} is formed between the gate and source of the driving TFT (DT), and a second parasitic capacitor C_{gs} is formed between the gate and drain of the driving TFT (DT). In the present invention, the capacitance of the compensation capacitor C_{gss} and first parasitic capacitor C_{gs} connected in parallel and the capacitance of the second parasitic capacitor C_{gd} connected in series to these capacitors C_{gss} and C_{gs} can be adjusted in order to improve

the threshold voltage compensation capability. By adjusting the capacitances of the above-mentioned capacitors, the above-described " α " on which the threshold voltage compensation capability depends is determined. In the present invention, the design size of the first and second parasitic capacitors C_{gs} and C_{gd} , in addition to the design size of the compensation capacitor C_{gss} , can be adjusted. Moreover, in the present invention, an adjustment capacitor C_{gds} may be further formed between the gate and drain of the driving TFT (DT), in order to supplement the capacitance of the second parasitic capacitor C_{gd} , if required.

[0063] FIG. 7 shows another example of the pixel P of FIG. 2.

[0064] Referring to FIG. 7, the pixel P according to another exemplary embodiment of the present invention comprises an OLED, a driving TFT (DT), first to fourth switching TFTs (ST1 to ST4), a compensation capacitor C_{gss} , and a storage capacitor C_{st} .

[0065] The pixel P according to another exemplary embodiment of the present invention is identical to that of FIG. 2, except for a connection structure of the third switching TFT (ST3). Unlike in FIG. 2, the third switching TFT (ST3) of FIG. 7 switches the current path between the input terminal of reference voltage V_{ref} and node A in response to the initialization signal INIT. The third switching TFT (ST3) is turned on to supply the reference voltage to not node B but node A. Even if the reference voltage V_{ref} is supplied to node A in the initialization period, the first switching TFT (ST1) is turned on during the initialization period to transmit the reference voltage V_{ref} of node A to node B. Accordingly, the operation of the pixel P of FIG. 7 is substantially identical to the pixel P of FIG. 2, regarding the sensing period, the programming period, and the emission period.

[0066] FIG. 8 shows a driving waveform of a gate signal suggested in the present invention, as compared to the conventional art. FIG. 9 shows the progress of threshold voltage degradation in accordance with the on duty of the gate signal.

[0067] Referring to (a) of FIG. 8, in a conventional pixel circuit, an EM TFT is connected between a driving TFT (DT) and an OLED to control light emission of the OLED. In the conventional art, SW TFTs are turned on prior to an emission period and turned off in the emission period, whereas the EM TFT is turned on only during the emission period. The emission period is relatively much longer than the other periods, and an ON-level light emission control signal is applied to the gate of the EM TFT during the entire emission period. It is inevitable that the EM TFT is further deteriorated than the SW TFTs, due to a positive bias stress applied for a long time.

[0068] Referring to (b) of FIG. 8, in the pixel circuit of the present invention, only the driving TFT (DT) and the OLED are serially connected between input terminals of cell driving voltages $EVDD$ and $EVSS$, and the conventional EM TFT is not connected between these input terminals $EVDD$ and $EVSS$. A light emission control signal

is applied to the first switching TFT (ST1) for transmitting a data voltage to induce light emission, as explained above, and is in the form of two pulses. The first switching TFT (ST1) is turned on by first and second pulses P1 and P2 having the ON level respectively corresponding to the initialization period and the first emission period. Since the first switching TFT (ST1) is turned off in response to an OFF-level light emission control signal in the second emission period, deterioration of the first switching TFT (ST1) caused by a positive gate bias stress is greatly reduced. Even if the first switching TFT (ST1) is turned off in the second emission period, the condition of light emission of the first emission period is kept nearly the same due to the compensation capacitor connected between the gate and source of the driving TFT. Meanwhile, the OFF period of all the TFTs including the first switching TFT (ST1) in one frame is much longer than the ON period thereof. However, the absolute value of the off voltage level of gate signals is much smaller than the absolute value of the on voltage level thereof. Thus, any problem caused by a negative bias stress is not significant and also ignorable.

[0069] The progress of deterioration of the threshold voltage of a TFT in accordance with the on duty of a gate signal is as shown in FIG. 9. Referring to FIG. 9, if the frame frequency is 120 Hz, 1 frame period is approximately 8.3 msec. According to a test, it was found that the on duty of a gate signal (especially, light emission control signal) within one frame may be set to approximately 5% or less, the effect of preventing threshold voltage deterioration becomes larger as the on duty of the gate signal is set to a lower level within a predetermined range. For example, as shown in FIG. 9, if the on duty of the light emission control signal is set to 2%, the threshold voltage of the TFT operated by the light emission control signal gradually rises and becomes deteriorated with the elapse of driving time. On the other hand, if the on duty of the light emission control signal is set to 0.1 %, the threshold voltage of the TFT is maintained nearly constant in spite of the elapse of driving time. In the present invention, the ON period of the first pulse of FIG. 4 can be further reduced within the on period of the initialization signal to reduce the on duty of the light emission control signal as much as possible.

[0070] FIG. 10 shows the result of simulation of the threshold voltage compensation performance of the pixel suggested in the present invention.

[0071] Referring to FIG. 10, according to the pixel circuit of the present invention, the threshold voltage compensation performance ranges from -2V to 4V, and the compensation range can be shifted, increased, or decreased according to power settings and how much the TFT and capacitor sizes are optimized. Especially, the threshold voltage compensation technique suggested in the present invention exhibits an excellent compensation performance even in low gray levels (63gray), as shown in FIG. 10.

[0072] As described above, the organic light emitting

display and driving method thereof according to the present invention has the following effects to overcome the problems occurring in the conventional art.

[0073] First, while the conventional compensation circuit method is limited to when the threshold voltage of a driving TFT has a positive value (or negative value), the present invention can detect a threshold voltage having a negative value, as well as a threshold voltage having a positive value, regardless of whether the TFT is the n-type or p-type by employing the source-follower method.

[0074] Second, in the conventional compensation circuit method a fixed potential is applied to the gate of the driving TFT upon sensing a threshold voltage; whereas, in the present invention, the gate of the driving TFT is allowed to float upon sensing a threshold voltage, and the threshold voltage compensation capability is improved by using the compensation capacitor connected between the gate and source of the driving TFT and a parasitic capacitor of the driving TFT. The present invention increases the accuracy of threshold voltage compensation by additionally amplifying the gate-source voltage of the driving TFT upon detecting a threshold voltage in consideration of distortion of threshold voltage compensation caused by the parasitic capacitor

[0075] Third, while, in the conventional compensation circuit, the light emission control TFT which is turned on during the entire emission period is easily deteriorated; whereas, in the present invention, deterioration of the switching TFTs to be switched in response to a gate signal can be minimized by minimizing the on duty of gate signals (especially, a light emission control signal). The present invention can enhance the reliability of the switching TFTs by minimizing deterioration caused by a gate bias stress.

[0076] Throughout the description, it should be understood for those skilled in the art that various changes and modifications are possible without departing from the technical principles of the present invention. Therefore, the technical scope of the present invention is not limited to those detailed descriptions in this document but should be defined by the scope of the appended claims.

Claims

1. An organic light emitting display comprising:

an organic light emitting diode;
 a driving TFT comprising a gate connected to a node B, a drain connected to an input terminal of high-potential cell driving voltage, and a source connected to the organic light emitting diode through a node C, and for controlling the current applied to the organic light emitting diode;
 a first switching TFT for switching the current path between a node A and the node B in response to a light emission control signal;

a second switching TFT for initializing the node C to an initialization voltage in response to an initialization signal;

a third switching TFT for initializing either the node A or the node B to a reference voltage higher than the initialization voltage in response to the initialization signal;

a fourth switching TFT for switching the current path between a data line and the node B in response to a scan signal;

a compensation capacitor connected between the node B and the node C; and

a storage capacitor connected between the node A and the node C.

2. The organic light emitting display of claim 1, wherein one frame period is divided into an initialization period for initializing the nodes A, B, and C, a sensing period for detecting and storing the threshold voltage of the driving TFT, a programming period for applying the data voltage, and an emission period for compensating the driving current applied to the organic light emitting diode using the threshold voltage and the data voltage, regardless of the threshold voltage; and the node B is allowed to float in the sensing period.

3. The organic light emitting display of claim 2, wherein, in the sensing period, the potential of the node C rises to an intermediate source voltage, which is obtained by adding a value obtained by subtracting the threshold voltage from the reference voltage and an amplification compensation factor for preventing distortion of the threshold voltage, and the potential of the node B rises to an intermediate gate voltage, which is obtained by adding the reference voltage and the amplification compensation factor.

4. The organic light emitting display of claim 3, wherein the value of the amplification compensation factor is adjusted by a parasitic capacitor of the driving TFT.

5. The organic light emitting display of claim 3, wherein an adjustment capacitor for adjusting the value of the amplification compensation factor is further connected between the node B and the input terminal of high-potential cell driving voltage.

6. The organic light emitting display of claim 2, the light emission control signal comprises a first pulse having the ON level corresponding to the initialization period and a second pulse having the ON level partially corresponding to the emission period.

7. The organic light emitting display of claim 6, wherein the emission period comprises a first emission period for applying a first driving current to the organic light emitting diode and a second emission period for ap-

plying a second driving current, which is lower than the first driving current, to the organic light emitting diode, the second emission period being longer than the first emission period.

8. The organic light emitting display of claim 6, wherein the ON period of the first pulse is set shorter than the on period of the initialization period within the on period of the initialization signal.
9. The organic light emitting display of claim 1, wherein a gate electrode of the third switching TFT is connected to a signal line to which the initialization signal is supplied, one electrode of the third switching TFT is connected to an input terminal of the reference voltage, and the other electrode of the third switching TFT is connected to either the node A or the node B.
10. A driving method of an organic light emitting display comprising a driving TFT comprising a gate connected to a nodeB, a drain connected to an input terminal of high-potential cell driving voltage, and a source connected to the organic light emitting diode through a node C, and for controlling the current applied to the organic light emitting diode, the method comprising:

initializing the node C to an initialization voltage in response to an initialization signal, and initializing the node B to a reference voltage higher than the initialization voltage in response to the initialization signal and a light emission control signal;

stopping the supply of the initialization voltage and allowing the node B to float, and then detecting and storing the threshold voltage of the driving TFT by using a compensation capacitor connected between the node B and the node C; applying a data voltage to a node A connected to a storage capacitor in response to a scan signal; and

transmitting the data voltage of the node A to the node B in response to the light emission control signal to compensate for the driving current applied to the organic light emitting diode, regardless of the threshold voltage, and causing the organic light emitting diode to emit light.

11. The method of claim 10, wherein, in the detecting and storing of the threshold voltage, the potential of the node C rises to an intermediate source voltage, which is obtained by adding a value obtained by subtracting the threshold voltage from the reference voltage and an amplification compensation factor for preventing distortion of the threshold voltage, and the potential of the node B rises to an intermediate gate voltage, which is obtained by adding the reference voltage and the amplification compensation

factor.

12. The method of claim 11, wherein the value of the amplification compensation factor is adjusted by a parasitic capacitor of the driving TFT.
13. The method of claim 10, wherein the light emission control signal comprises a first pulse having the ON level corresponding to the initialization period and a second pulse having the ON level partially corresponding to the emission period.
14. The method of claim 10, wherein the organic light emitting diode emits light in an emission period; and Wherein the emission period comprises a first emission period in which the organic light emitting diode emits light by a first driving current and a second emission period in which the organic light emitting diode emits light by a second driving current, the second emission period being longer than the first emission period.

FIG. 1

(REALTED ART)

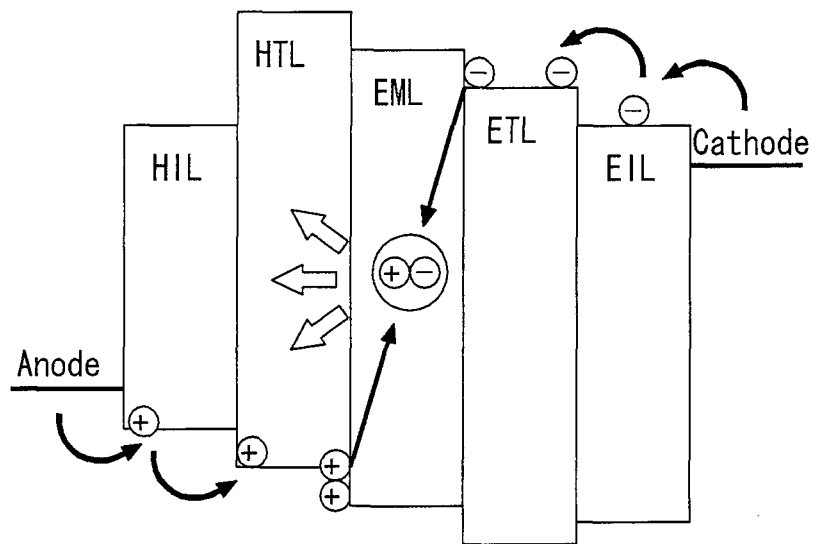

FIG. 2

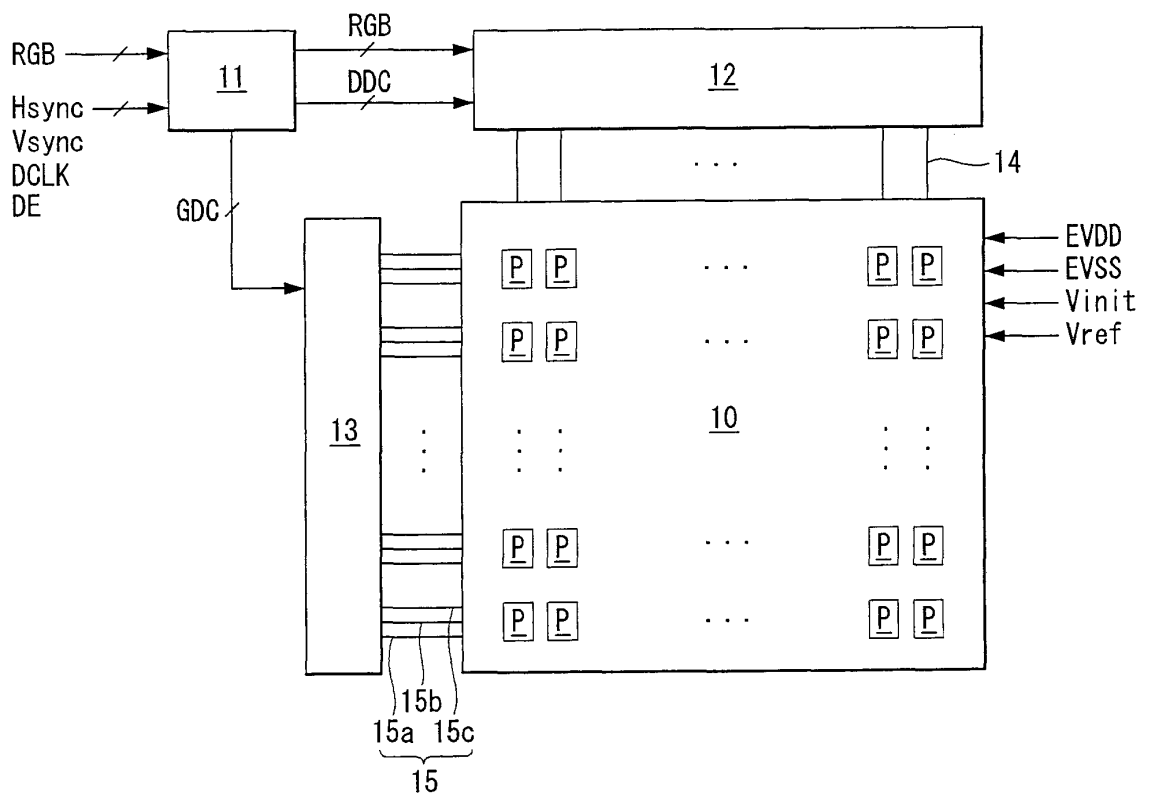

FIG. 3

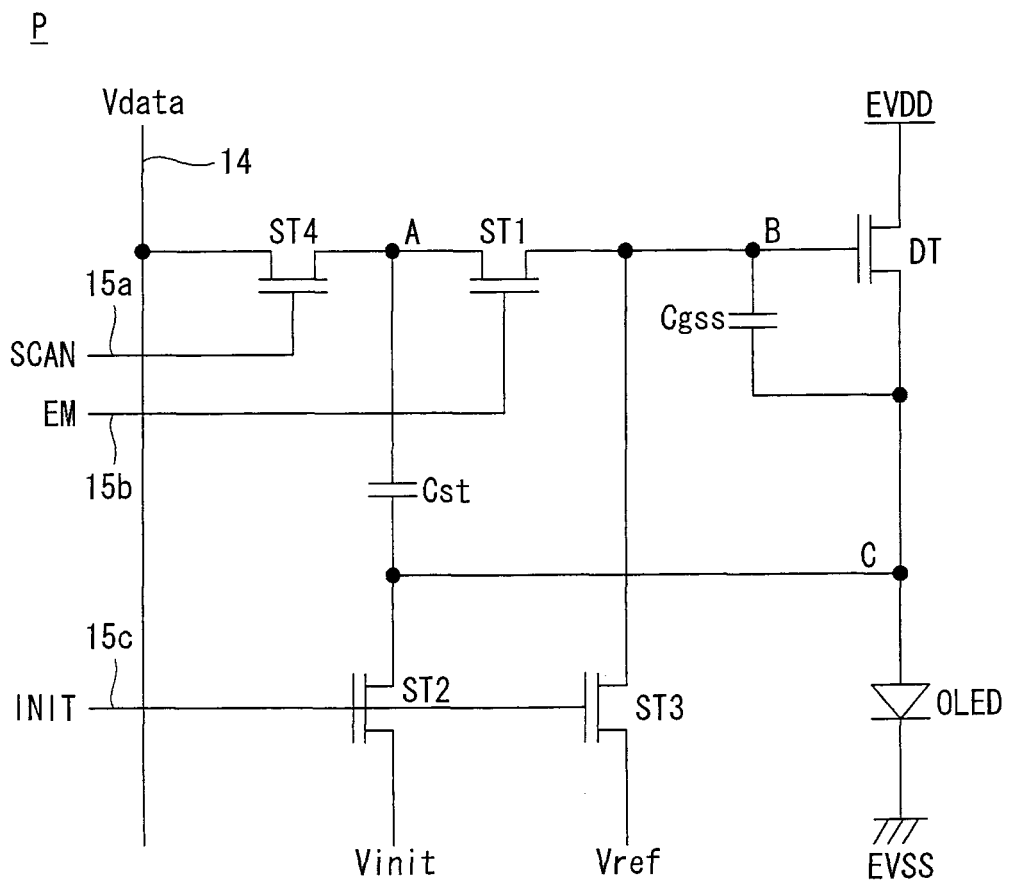

FIG. 4

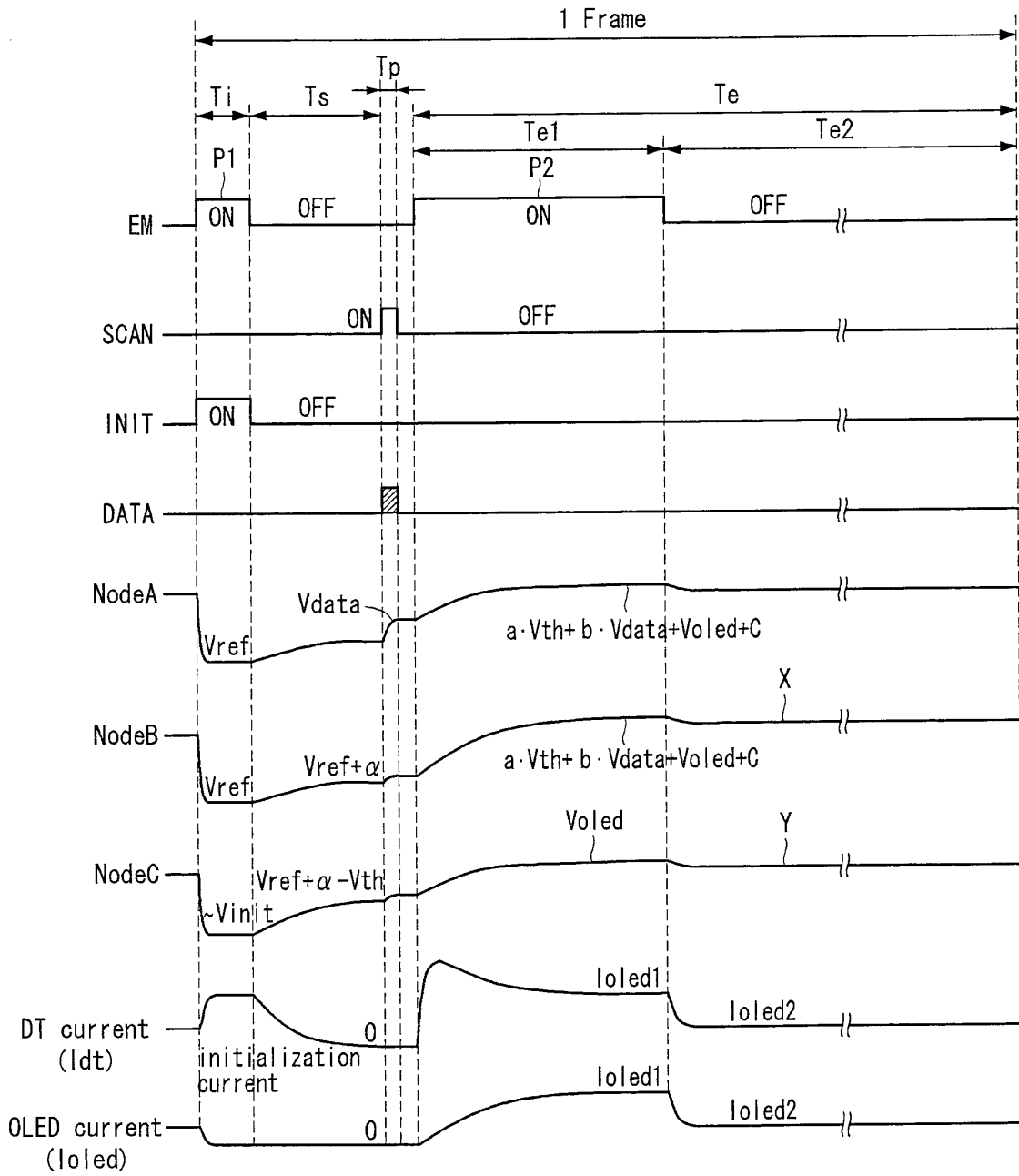

FIG. 5A

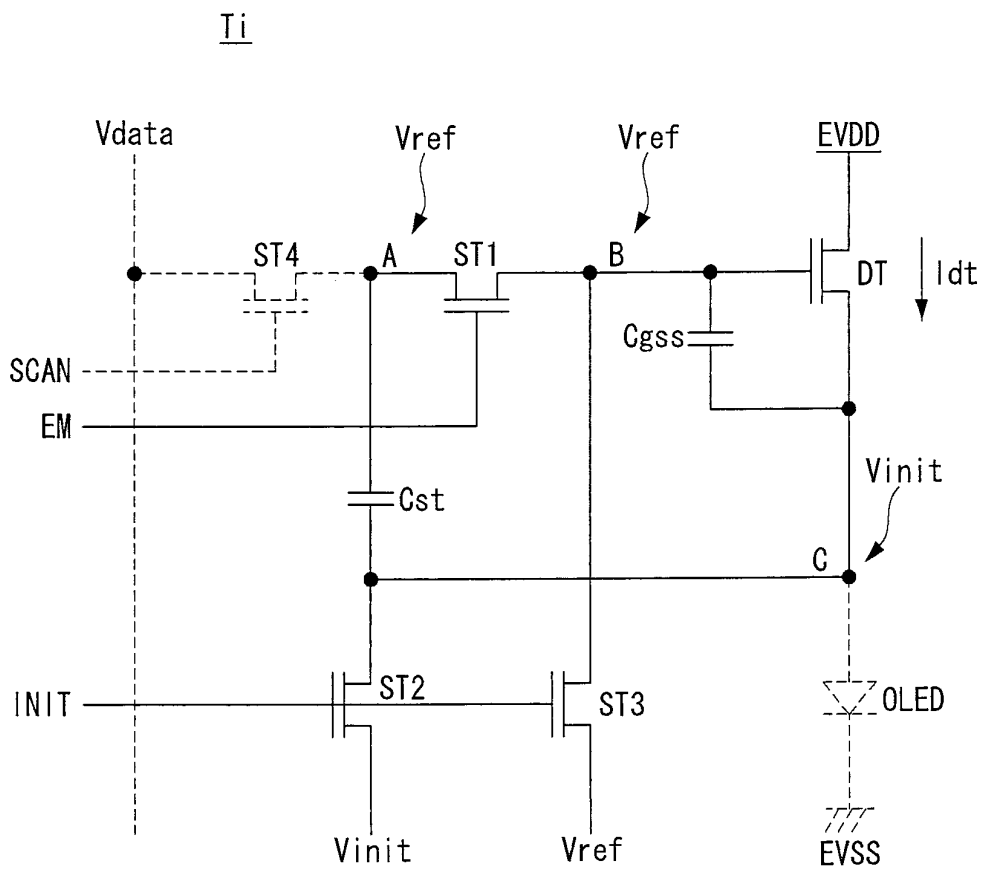

FIG. 5B

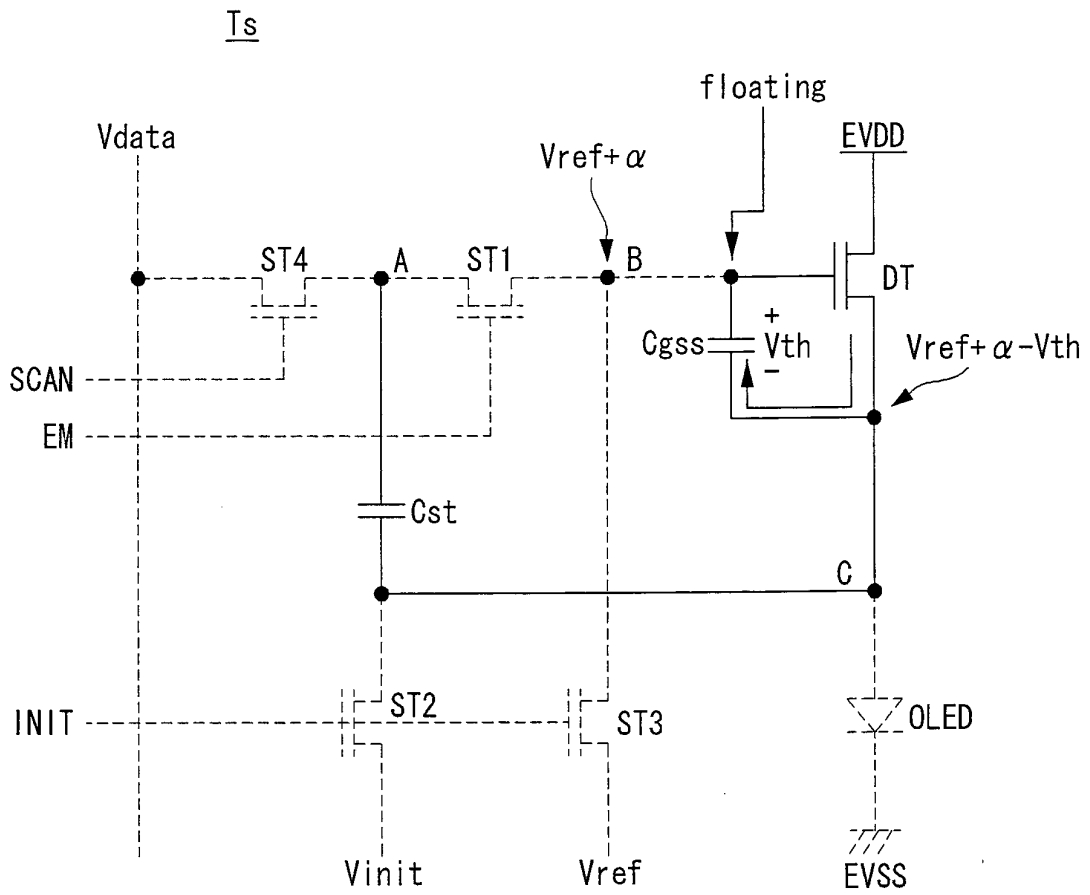

FIG. 5C

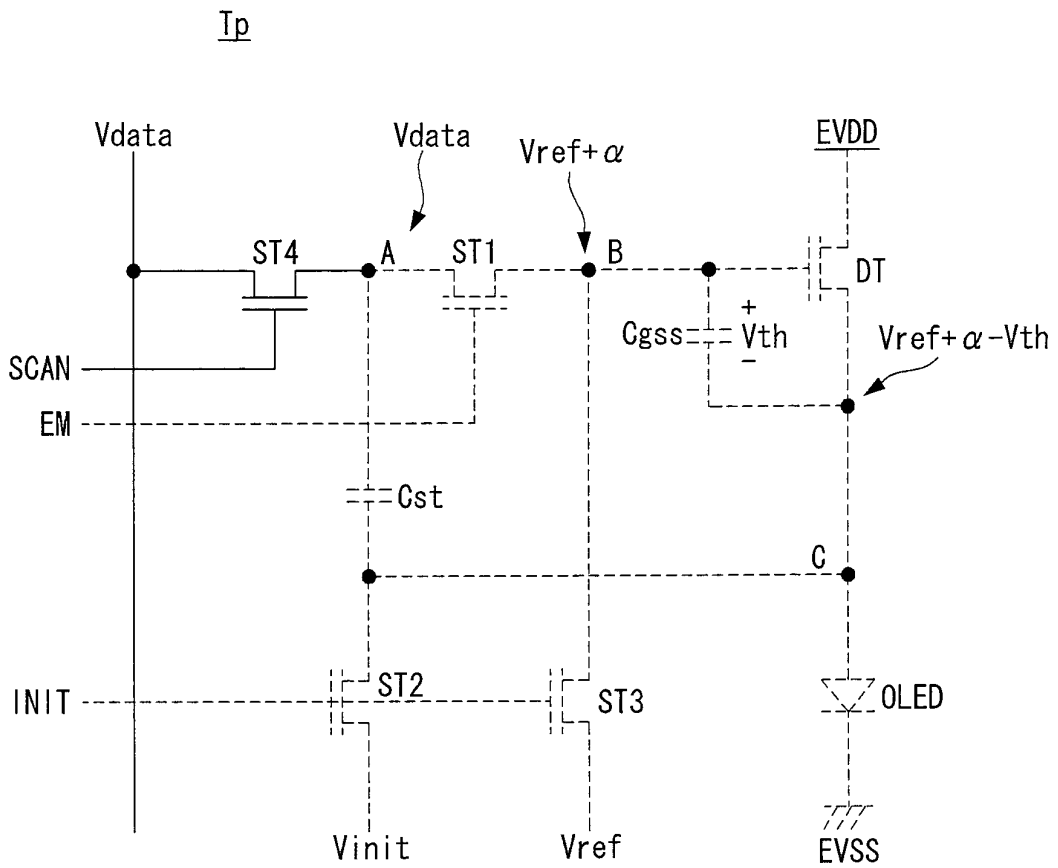

FIG. 5D

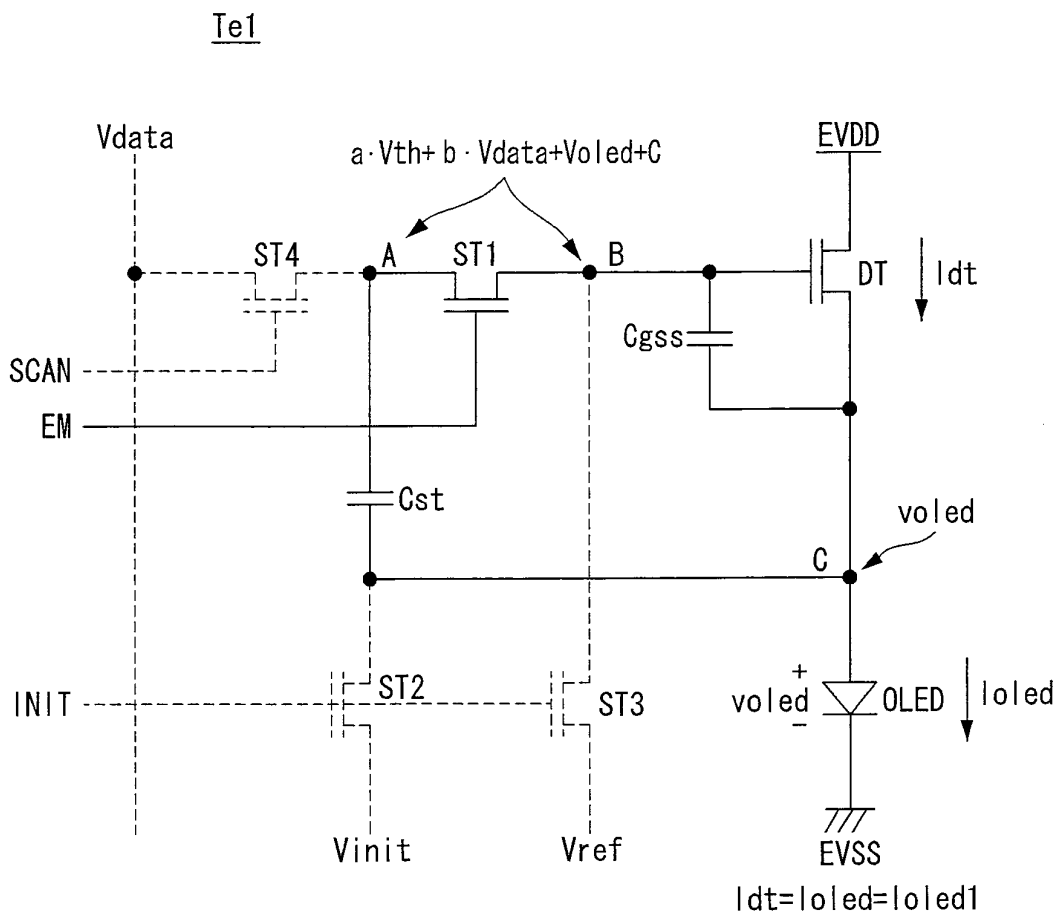

FIG. 5E

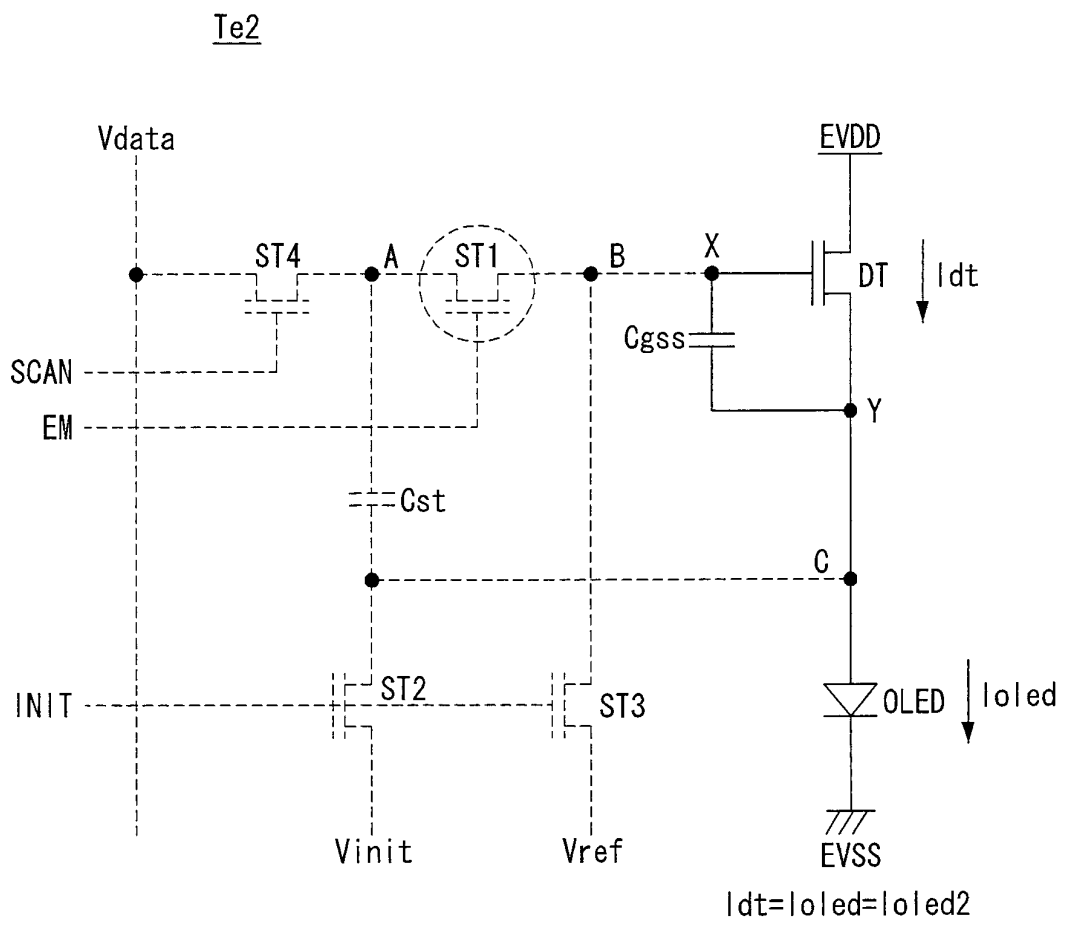

FIG. 6

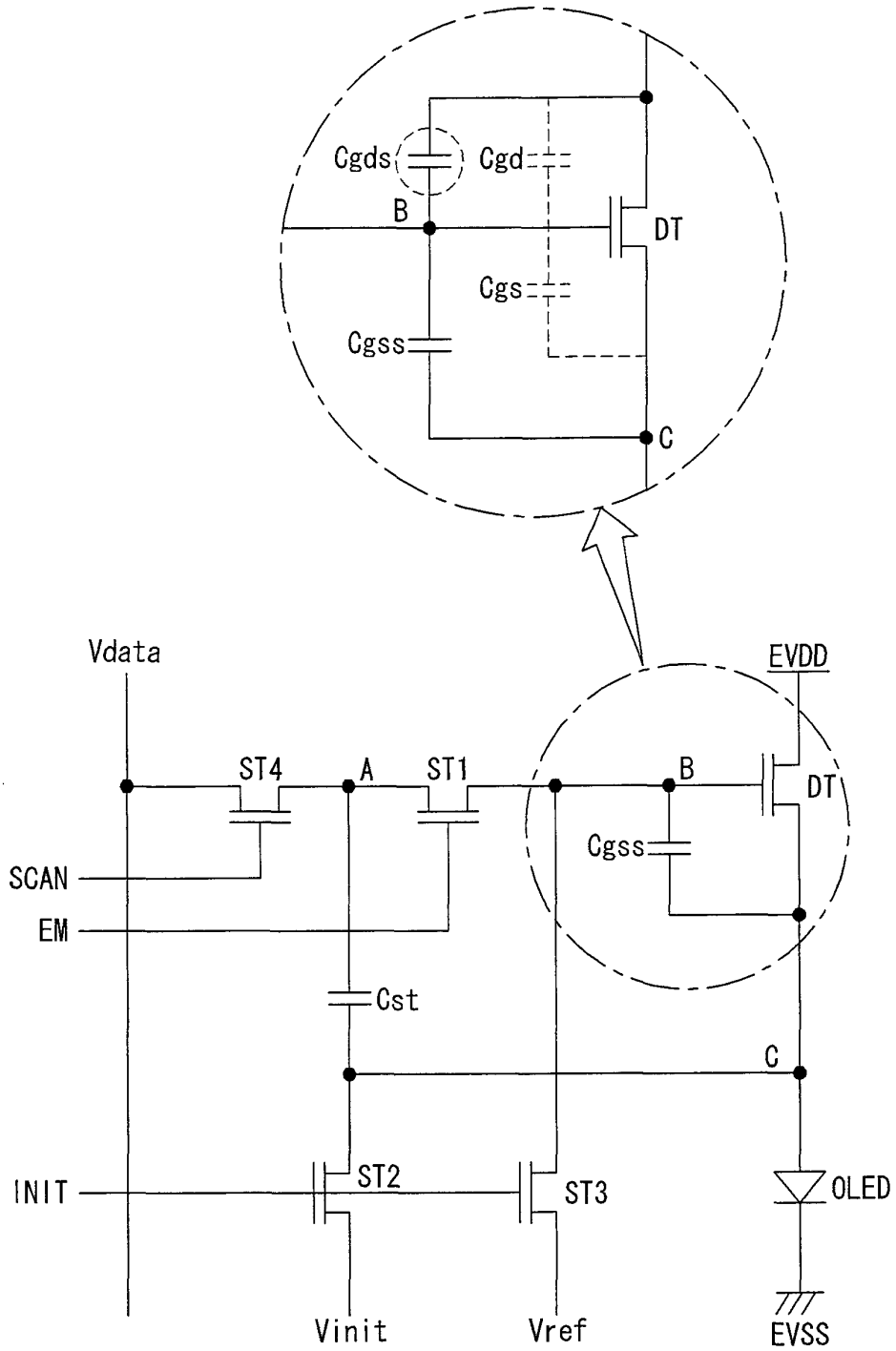

FIG. 7

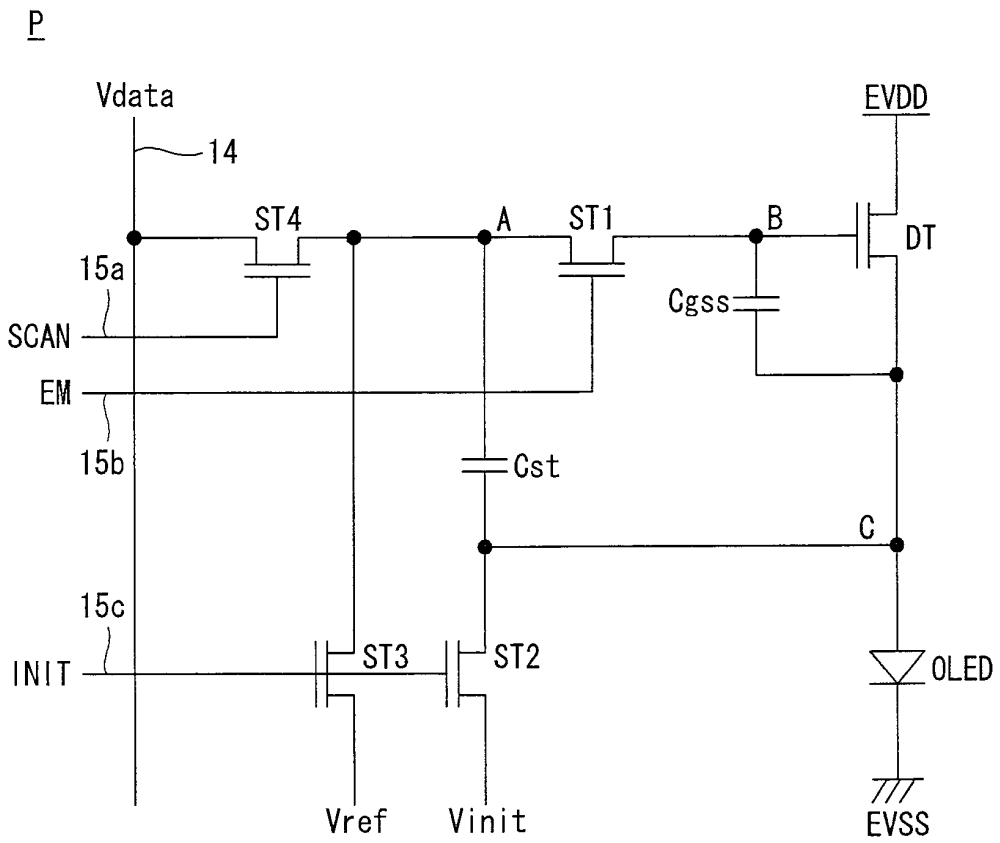

FIG. 8

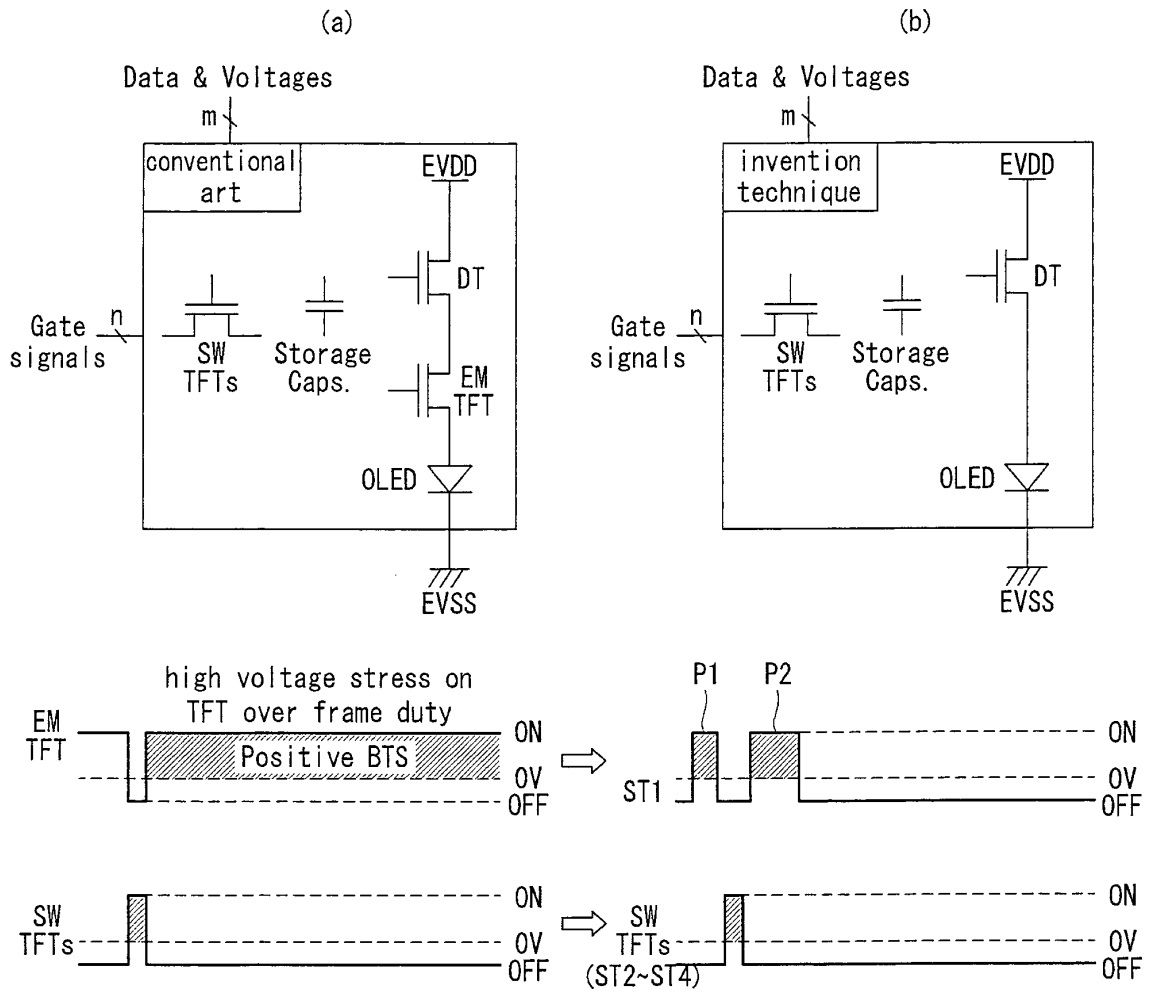

FIG. 9

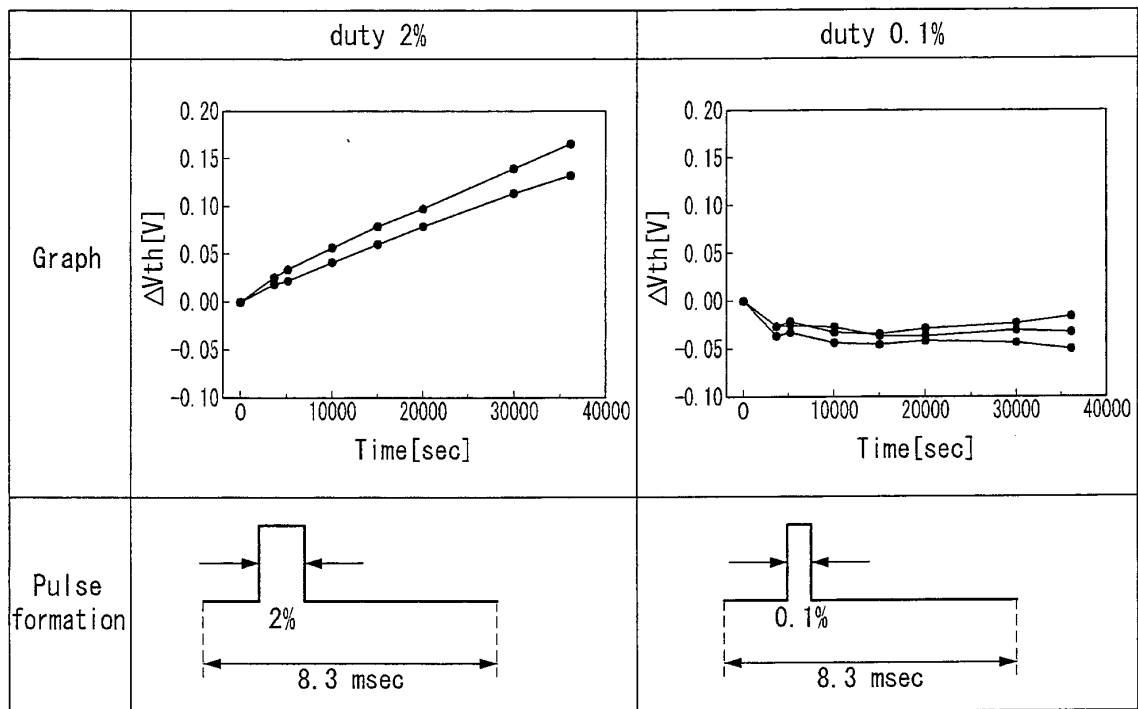
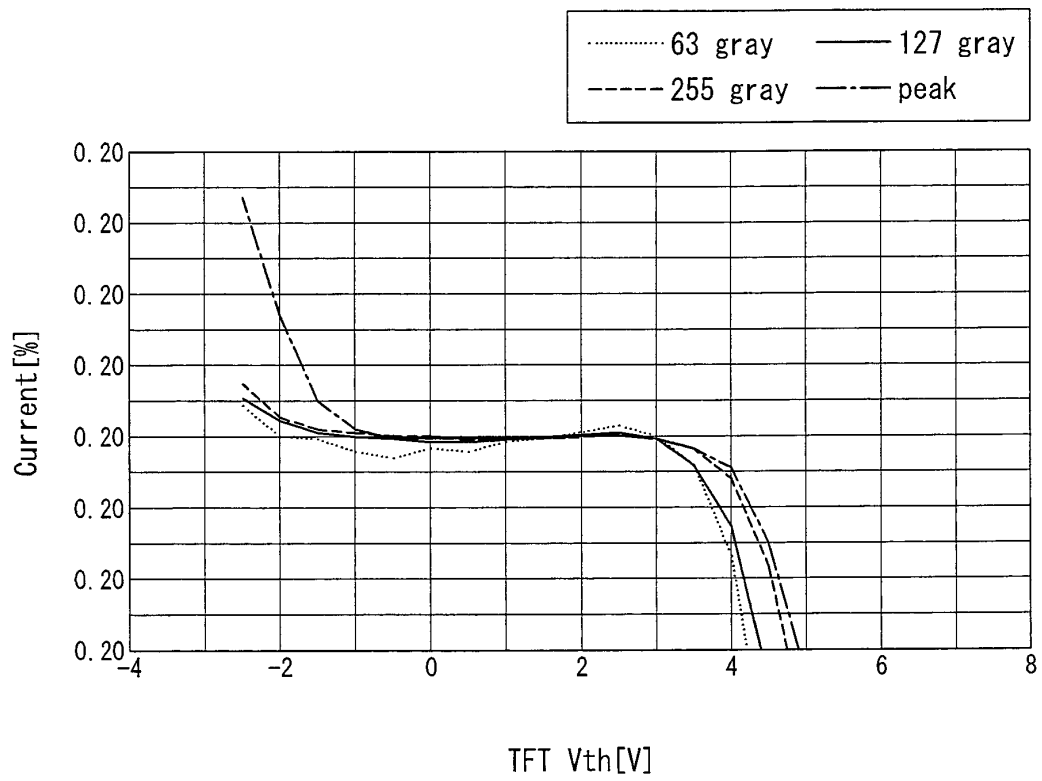

FIG. 10





EUROPEAN SEARCH REPORT

Application Number
EP 12 00 7398

DOCUMENTS CONSIDERED TO BE RELEVANT			
Category	Citation of document with indication, where appropriate, of relevant passages	Relevant to claim	CLASSIFICATION OF THE APPLICATION (IPC)
X	US 2011/157143 A1 (CHOI SANG-MOO [KR] ET AL) 30 June 2011 (2011-06-30) * paragraphs [0003], [0056] - [0057], [0090] - [0101]; figures 3,6 *	1,9	INV. G09G3/32
X	US 2012/154352 A1 (YAMASHITA JUNICHI [JP] ET AL) 21 June 2012 (2012-06-21) * paragraphs [0241], [0242], [0247], [0250] - [0254], [0256] - [0258], [0265] - [0269]; figures 3,22 *	10-12	
			TECHNICAL FIELDS SEARCHED (IPC)
			G09G
The present search report has been drawn up for all claims			
Place of search Munich		Date of completion of the search 27 June 2013	Examiner Adarska, Veneta
CATEGORY OF CITED DOCUMENTS X : particularly relevant if taken alone Y : particularly relevant if combined with another document of the same category A : technological background O : non-written disclosure P : intermediate document		T : theory or principle underlying the invention E : earlier patent document, but published on, or after the filing date D : document cited in the application L : document cited for other reasons & : member of the same patent family, corresponding document	

1

EPO FORM 1503 03.82 (F04C01)

**ANNEX TO THE EUROPEAN SEARCH REPORT
ON EUROPEAN PATENT APPLICATION NO.**

EP 12 00 7398

This annex lists the patent family members relating to the patent documents cited in the above-mentioned European search report. The members are as contained in the European Patent Office EDP file on
The European Patent Office is in no way liable for these particulars which are merely given for the purpose of information.

27-06-2013

Patent document cited in search report	Publication date	Patent family member(s)	Publication date
US 2011157143 A1	30-06-2011	KR 20110078396 A US 2011157143 A1	07-07-2011 30-06-2011

US 2012154352 A1	21-06-2012	CN 102568440 A JP 2012128149 A US 2012154352 A1	11-07-2012 05-07-2012 21-06-2012

EPO FORM P0459

For more details about this annex : see Official Journal of the European Patent Office, No. 12/82

REFERENCES CITED IN THE DESCRIPTION

This list of references cited by the applicant is for the reader's convenience only. It does not form part of the European patent document. Even though great care has been taken in compiling the references, errors or omissions cannot be excluded and the EPO disclaims all liability in this regard.

Patent documents cited in the description

- KR 1020120095604 [0001]
- KR 1020050122699 [0006]

专利名称(译)	有机发光显示器及其驱动方法		
公开(公告)号	EP2704131A1	公开(公告)日	2014-03-05
申请号	EP2012007398	申请日	2012-10-29
[标]申请(专利权)人(译)	乐金显示有限公司		
申请(专利权)人(译)	LG DISPLAY CO. , LTD.		
当前申请(专利权)人(译)	LG DISPLAY CO. , LTD.		
[标]发明人	NAM WOJIN SHIM JONGSIK SHIN HONGJAE CHANG MINKYU		
发明人	NAM, WOJIN SHIM, JONGSIK SHIN, HONGJAE CHANG, MINKYU		
IPC分类号	G09G3/32		
CPC分类号	G09G3/3233 G09G3/3266 G09G2300/0819 G09G2300/0852 G09G2300/0861 G09G2310/067 G09G2320/0223 G09G2320/043 G09G2320/045		
优先权	1020120095604 2012-08-30 KR		
其他公开文献	EP2704131B1		
外部链接	Espacenet		

摘要(译)

一种有机发光显示器，包括：驱动TFT (DT)，包括连接到节点B的栅极，连接到高电位单元驱动电压的输入端子的漏极，以及通过节点连接到有机发光二极管的源极C;第一开关TFT (ST1)，用于响应发光控制信号切换节点A和节点B之间的电流路径;第二开关TFT (ST2)，用于响应初始化信号初始化节点C;第三开关TFT (ST3)，用于响应初始化信号初始化节点A或节点B;第四开关TFT (ST4)，用于响应扫描信号切换数据线 (14) 和节点B之间的电流路径;连接在节点B和节点C之间的补偿电容器 (C_{gss})。

FIG. 1

(REALTED ART)

