



(11) **EP 1 970 885 A1**

(12) **EUROPEAN PATENT APPLICATION**

(43) Date of publication:  
**17.09.2008 Bulletin 2008/38**

(51) Int Cl.:  
**G09G 3/32<sup>(2006.01)</sup>**

(21) Application number: **08152784.8**

(22) Date of filing: **14.03.2008**

(84) Designated Contracting States:  
**AT BE BG CH CY CZ DE DK EE ES FI FR GB GR  
HR HU IE IS IT LI LT LU LV MC MT NL NO PL PT  
RO SE SI SK TR**  
Designated Extension States:  
**AL BA MK RS**

(72) Inventor: **Kim, Yang-Wan,**  
**Samsung SDI Co., LTD.**  
**Suwon-si, Gyeonggi-do (KR)**

(30) Priority: **14.03.2007 KR 20070025063**

(74) Representative: **Hengelhaupt, Jürgen et al**  
**Anwaltskanzlei**  
**Gulde Hengelhaupt Ziebig & Schneider**  
**Wallstrasse 58/59**  
**10179 Berlin (DE)**

(71) Applicant: **Samsung SDI Co., Ltd.**  
**Suwon-si**  
**Gyeonggi-do (KR)**

(54) **Pixel, organic light emitting display using the same, and associated methods**

(57) A pixel for driving an OLED, including a first transistor coupled between a data line and a first node, the first transistor being turned on by a low signal on an i-th scan line, a second transistor coupled between a first power source and a fifth transistor, a third transistor coupled between the gate electrode of the second transistor and an electrode of the second transistor that is coupled to the fifth transistor, the third transistor being turned on

by a low signal on an (i-1)-th scan line, a fourth transistor coupled between a first reference voltage and the first node, the fourth transistor being turned on by the low signal on the (i-1)-th scan line, a storage capacitor coupled between the first node and the second node, and a compensator controlling a voltage of the second node corresponding to degradation of the OLED.

**EP 1 970 885 A1**

## Description

### BACKGROUND OF THE INVENTION

#### 1. Field of the Invention

[0001] Embodiments relate to a pixel, an organic light emitting display using the same, and associated methods. More particularly, embodiments relate to a pixel, an organic light emitting display using the same, and associated methods, in which degradation of an organic light emitting diode is automatically compensated.

#### 2. Description of the Related Art

[0002] In the manufacture and operation of a display, e.g., a display used to reproduce text, images, video, etc., uniform operation of pixel elements of the display is highly desirable. However, providing such uniform operation may be difficult. For example, in some display technologies, e.g., those utilizing organic light emitting diodes (OLEDs), operational characteristics, e.g., luminance, of the pixel elements may change over time. Accordingly, there is a need for a display adapted to compensate for changes in the operational characteristics of pixel elements.

### SUMMARY OF THE INVENTION

[0003] A first aspect of the invention therefore provides a pixel comprising an OLED and a pixel circuit for driving the OLED. The pixel circuit comprises a first transistor for passing a data signal in response to an  $i$ -th scan signal and having a first electrode coupled to a data line and a second electrode coupled to a first node, and a gate electrode coupled to an  $i$ -th scan line for the  $i$ -th scan signal. The first node is adapted to capacitively store a data signal transferred to it by the first transistor. According to the invention, the pixel comprises a compensator having a control input coupled to the  $i$ -th scan line and a first input coupled to an anode of the OLED. The compensator is adapted to sense an anode voltage at the first input in response to the  $i$ -th scan signal and to provide a compensation voltage dependent on the sensed anode voltage to the first node of the pixel circuit.

[0004] Preferably, the pixel circuit comprises a second transistor having a first electrode coupled to a first power source for providing a first power supply voltage and a gate electrode coupled to a second node, a third transistor having a first electrode coupled to the gate electrode of the second transistor, a second electrode coupled to a second electrode of the second transistor, and a gate electrode coupled to an  $(i-1)$ -th scan line, a fourth transistor having a first electrode coupled to a first reference voltage source, a second electrode coupled to the first node, and a gate electrode coupled to the  $(i-1)$ -th scan line, a fifth transistor having a first electrode coupled to the second electrode of the second transistor, a second

electrode coupled to the anode of the OLED, and a gate electrode coupled to an  $i$ -th emission control line, and a storage capacitor having a first electrode coupled to the first node and a second electrode coupled to the second node.

[0005] A second aspect of the invention provides a display comprising a scan driver, a data driver, and a plurality of pixels. The scan driver is coupled to a plurality of scan lines and a plurality of emission control lines. The data driver is coupled to a plurality of data lines. The pixels are coupled to respective ones of the scan lines, the emission control lines, and the data lines. The pixels are pixels according to the first aspect of the invention.

[0006] A third aspect of the invention provides a method of driving a pixel of an OLED display device which allows for compensation of degradation of the OLEDs.

### BRIEF DESCRIPTION OF THE DRAWINGS

[0007] The above and other features and advantages will become more apparent to those of ordinary skill in the art by describing in detail example embodiments with reference to the attached drawings, in which:

FIG. 1 illustrates a schematic view of a display according to an embodiment;

FIG. 2 illustrates a schematic circuit diagram of a pixel according to an embodiment; and

FIG. 3 illustrates a waveform diagram for a method of driving a display according to an embodiment.

### DETAILED DESCRIPTION OF THE INVENTION

[0008] Example embodiments will now be described more fully hereinafter with reference to the accompanying drawings; however, they may be embodied in different forms and should not be construed as limited to the embodiments set forth herein. Rather, these embodiments are provided so that this disclosure will be thorough and complete, and will fully convey the scope of the invention to those skilled in the art.

[0009] Where an element is described as being coupled to a second element, the element may be directly coupled to second element, or may be indirectly coupled to second element via one or more other elements. Further, where an element is described as being coupled to a second element, it will be understood that the elements may be electrically coupled, e.g., in the case of transistors, capacitors, power sources, nodes, etc. Where two or more elements are described as being coupled to a node, the elements may be directly coupled to the node, or may be coupled via conductive features to which the node is common. Thus, where embodiments are described or illustrated as having two or more elements that are coupled at a common point, it will be appreciated that the elements may be coupled at respective points on a conductive feature that extends between the respective points. In general, the term "coupling" may refer to an

electrical connection between two elements. Like reference numerals refer to like elements throughout.

**[0010]** FIG. 1 illustrates a schematic view of a display 100 according to an embodiment. With reference to FIG. 1, the display 100 may include a plurality of pixels 140 each coupled to an OLED. The display 100 may group sets of pixel 140, each controlling display of a predetermined color of light, into a logical pixel, i.e., a pixel defining a display resolution. For example, the display 100 may group sets of red, green, and blue light pixels 140 into a logical pixel. In such a case, each pixel 140 forming the set may correspond to a sub-pixel. For clarity, in the description that follows no distinction will be made between sub-pixels of various colors. It will be appreciated, however, that the features described herein may be applied to monochrome displays, individual light emitting elements, color displays, etc.

**[0011]** The display 100 may include a pixel portion 130 having the pixel 140, a scan driver 110, a data driver 120, and a timing controller 150. The plurality of pixels 140 may be coupled to scan lines S1 to Sn, emission control lines E1 to En, and data lines D 1 to Dm. The scan driver 110 may drive the scan lines S1 to Sn with a scan signal applied sequentially from S1 to Sn, and may drive the emission control lines E1 to En with an emission control signal applied sequentially thereto. The data driver 120 may drive the data lines D1 to Dm. The timing controller 150 may control the scan driver 110 and the data driver 120.

**[0012]** Each pixel 140 may be coupled to a respective one of the scan lines S 1 to Sn, e.g., a scan line Si, where i is from 1 to n, inclusive. Each pixel 140 may also be coupled to a corresponding one of the emission control lines E1 to En, e.g., Ei, as well as one of the data lines D1 to Dm, e.g., Dj, where j is from 1 to m, inclusive. Further, each pixel 140 may be coupled to a scan line Si-1 that is scanned earlier in time. For example, where the pixels 140 are arranged in rows and columns in the display 100, each pixel 140 in a row i may be coupled to a scan line Si as well as a scan line Si-1 of a row i-1, which receives the scan signal prior to the row i. Further, a 0-th scan line S0 (not shown), i.e., Si-1 where i=1, may also be formed in the pixel portion 130 to provide an initialization operation to pixels driven by the first scan line S 1.

**[0013]** The pixel portion 130 may receive externally-supplied power from a first power source ELVDD and a second power source ELVSS. The first power source ELVDD may be set to a voltage higher than that of the second power source ELVSS. Each pixel 140 may control an amount of electric current flowing from the first power source ELVDD through the OLED to the second power source ELVSS. The OLED may generate light of a predetermined luminance based on the amount of current flowing therethrough. In particular, each of the pixels 140 may include a drive transistor for supplying an electric current to the OLED. As described herein, embodiments may provide a voltage to a gate electrode of the drive transistor that is controlled to compensate for

changing resistance in the OLED, e.g., an increased resistance resulting from degradation of the OLED.

**[0014]** The timing controller 150 may generate a data driving signal DCS and a scan driving signal SCS corresponding to externally-supplied synchronizing signals. The data driving signal DCS may be provided to the data driver 120, and the scan driving signal SCS may be provided to the scan driver 110. Further, the timing controller 150 may provide externally-supplied data DATA to the data driver 120.

**[0015]** The scan driver 110 may receive the scan driving control signal SCS from the timing controller 150 and sequentially provide a scan signal to the scan lines S 1 through Sn. Further, the scan driver 110 may sequentially provide an emission control signal to the emission control lines E1 to En. In an implementation, the scan signal may include a negative voltage pulse, i.e., a low pulse, and the emission control signal may include a positive voltage pulse, i.e., a high pulse. The data driver 120 may receive the data driving signal DCS and the data DATA, and may generate and provide data signals to the data lines D 1 through Dm.

**[0016]** FIG. 2 illustrates a schematic circuit diagram of a pixel 140 according to an embodiment. For convenience of description, FIG. 2 shows an example pixel 140 coupled to an (i-1)-th scan line Si-1, an i-th scan line Si, an i-th emission control line Ei, and a j-th data line Dj. With reference to FIG. 2, the pixel 140 may be coupled to an OLED. The pixel 140 may include a pixel circuit 142 and a compensator 144. The pixel circuit 142 may include five transistors M1 to M5 and a storage capacitor Cst. The second transistor M2 may be a drive transistor. The compensator 144 may include a sixth transistor M6, a seventh transistor M7, and a feedback capacitor Cfb.

**[0017]** The pixel circuit 142 may control an amount of an electric current supplied to the OLED and the compensator 144 may compensate for degradation in the OLED, e.g., an increase in resistance resulting from degradation of the OLED. An anode electrode of the OLED may be coupled to the pixel circuit 142, and a cathode electrode of the OLED may be coupled to the second power source ELVSS. The OLED may generate light of a predetermined luminance corresponding to an electric current supplied from the pixel circuit 142, which controls the electric current supplied to the OLED.

**[0018]** Degradation of the OLED, e.g., due to operation thereof or exposure to environmental factors, may occur over time. According to embodiments, as the resistance changes, a voltage applied to the OLED may be compensated, e.g., by increasing the voltage to compensate for an increased resistance. In particular, an electric current flowing from the second transistor M2 to the OLED may be controlled to maintain a uniform light output from the OLED by increasing the voltage applied to the OLED in response to increasing resistance thereof.

**[0019]** An amount of an electric current supplied to the OLED from the second transistor M2 may be increased for a given data signal, i.e., the electric current supplied

to the OLED may be increased as the OLED degrades. Thus, embodiments may compensate so as to maintain luminance if the OLED degrades.

**[0020]** In the pixel circuit 142, a gate electrode of the first transistor M1 may be coupled to the  $i$ -th scan line  $S_i$ , a first electrode of the first transistor M1 may be coupled to the data line  $D_j$ , and a second electrode of the first transistor M1 may be coupled to the first node N1. When the scan signal supplied to the scan line  $S_i$  is at a low level, the first transistor M1 may transfer the data signal from the data line  $D_j$  to the first node N1.

**[0021]** The second transistor M2 may be the drive transistor. A gate electrode of the second transistor M2 may be coupled to the second node N2, and a first electrode of the second transistor M2 may be coupled to the first power source ELVDD. A second electrode of the second transistor M2 may be coupled to a first electrode of the fifth transistor M5. The second transistor M2 may control the amount of electric current flowing from the first power source ELVDD to the second power source ELVSS through the OLED in correspondence with a voltage at the gate electrode.

**[0022]** A gate electrode of the third transistor M3 may be coupled to the  $(i-1)$ -th scan line  $S_{i-1}$ , a first electrode of the third transistor M3 may be coupled to the second electrode of the second transistor M2, and a second electrode of the third transistor M3 may be coupled to the second node N2. When the scan signal supplied to the  $(i-1)$ -th scan line  $S_{i-1}$  is low, the third transistor M3 may be turned on to couple the second electrode of the second transistor M2 to the gate thereof.

**[0023]** A gate electrode of the fourth transistor M4 may be coupled to the  $(i-1)$ -th scan line  $S_{i-1}$ , a first electrode of the fourth transistor M4 may be coupled to the first reference voltage  $V_{ref1}$ , and a second electrode of the fourth transistor M4 may be coupled to the first node N1. When the scan signal supplied to the  $(i-1)$ -th scan line  $S_{i-1}$  is low, the fourth transistor M4 may be turned on to supply the first reference voltage  $V_{ref1}$  to the first node N1. The first reference voltage  $V_{ref1}$  may be set to the same voltage as that of the first power source ELVDD, and may be set to a voltage higher than that of the data signal.

**[0024]** A gate electrode of the fifth transistor M5 may be coupled to the emission control line  $E_i$ , the first electrode of the fifth transistor M5 may be coupled to the second electrode of the second transistor M2, and a second electrode of the fifth transistor M5 may be coupled to the OLED. When an emission control signal supplied to the fifth transistor M5 is low, the fifth transistor M5 may be turned on, and when the emission signal is high, the fifth transistor M5 may be turned off.

**[0025]** The storage capacitor  $C_{st}$  may be disposed between the first node N1 and the second node N2. The storage capacitor  $C_{st}$  may be charged with a voltage corresponding to the data signal and a threshold voltage of the second transistor M2, as described in detail below.

**[0026]** The compensator 144 may adjust a voltage of

the gate electrode of the second transistor M2, via the second node N2, in correspondence with degradation of the OLED, i.e., the compensator 144 may control the voltage of the second node N2 to offset changes in resistance of the OLED. As noted above, the compensator 144 may include the sixth transistor M6, the seventh transistor M7, and the feedback capacitor  $C_{fb}$ . The feedback capacitor  $C_{fb}$  may transfer a voltage change of the third node N3 to the first node N1, as described in detail below.

The seventh transistor M7 may be a transistor of a different conductivity type from that of each of the first to sixth transistors M1 to M6. The seventh transistor may be an NMOS transistor and the first to sixth transistors M1 to M6 may be PMOS transistors.

**[0027]** A second electrode of the sixth transistor M6 may be coupled to an anode electrode of the OLED via a fourth node N4, a first electrode of the sixth transistor M6 may be coupled to the third node N3, and gate electrode of the sixth transistor M6 may be coupled to the  $i$ -th scan line  $S_i$ . When the scan signal supplied to the  $i$ -th scan line  $S_i$  is low, the sixth transistor M6 may be turned on to couple the third node N3 to the anode electrode of the OLED, and may thus change a voltage of the third node N3 to be that of the OLED anode. The seventh transistor M7 may be turned off when the sixth transistor M6 is turned on.

**[0028]** A first electrode of the seventh transistor M7 may be coupled to a second reference voltage  $V_{ref2}$ , a second electrode of the seventh transistor M7 may be coupled to the third node N3, and a gate electrode of the seventh transistor M7 may be coupled to the  $i$ -th scan line  $S_i$ . When the scan signal supplied to the  $i$ -th scan line  $S_i$  is low, the seventh transistor M7 may be turned off, and when the scan signal supplied to the  $i$ -th scan line  $S_i$  is high, the seventh transistor M7 may be turned on. The second reference voltage  $V_{ref2}$  may have a voltage greater than that applied to the OLED. For example, the second reference voltage  $V_{ref2}$  may be set to the same voltage as that of the first reference voltage  $V_{ref1}$ .

**[0029]** Referring again to FIG. 2, a voltage change occurring at a third node N3 may be used to adjust the operation of the second transistor M2. As the OLED degrades, increasing resistance of the OLED results in an increase in the voltage supplied to the third node N3. This changes a voltage charged in a feedback capacitor  $C_{fb}$  that is coupled to the third node N3. The voltage charged in the feedback capacitor may be lower as the OLED degrades. In turn, voltages of a first node N1 and a second node N2 coupled to the second transistor M2 are also reduced. Thus, an amount of an electric current supplied to the OLED from the second transistor M2 may be increased for a given data signal, i.e., the electric current supplied to the OLED may be increased as the OLED degrades.

**[0030]** FIG. 3 illustrates a waveform diagram for a method of driving a display according to an embodiment. With reference to FIGS. 2 and 3, a scan signal having a low level may be supplied to an  $(i-1)$ -th scan line  $S_{i-1}$

during a first time period T1. When the scan signal supplied to the (i-1)-th scan line Si-1 is low, the fourth transistor M4 and the third transistor M3 may be turned on. The emission signal supplied to the emission control line Ei may be low during the first time period T1. When the emission signal supplied to the emission control line Ei is low, the fifth transistor M5 may be turned on.

**[0031]** When the fourth transistor M4 is turned-on, a voltage of the first reference voltage Vref1 may be supplied to the first node N1.

**[0032]** With the third transistor M3 turned on, the second node N2 may be coupled to the second power source ELVSS through the fifth transistor M5 and the OLED. Thus, during the first time period T1, the voltage of the second node N2 may be initialized, and a voltage stored in the storage capacitor Cst may correspond to a voltage difference between the first reference voltage Vref1 and the voltage at the anode electrode of the OLED.

**[0033]** During a second time period T2, the scan signal supplied to the (i-1)-th scan line Si-1 may be maintained low, and the second electrode and gate of the second transistor M2 may remain coupled. The emission control signal supplied to the emission control line Ei may be high, such that the fifth transistor M5 is turned off. As described above, during the first time period T1, the storage capacitor Cst may be charged with a voltage corresponding to the first reference voltage Vref1 and the voltage at the anode electrode of the OLED. During the second time period T2, a voltage obtained by subtracting a threshold voltage of the second transistor M2 from a voltage of the first power source ELVDD may be developed at the second node N2.

**[0034]** In particular, during the second time period T2, the voltage at the second node N2, which is applied to the gate electrode of the second transistor M2 by the storage capacitor Cst, may be initially low, placing the second transistor M2 in a conductive state. Further, the third transistor M3 may be turned on by the low scan signal supplied to the (i-1)-th scan line Si-1, thereby coupling the second node N2 to the second electrode of the second transistor M2. Accordingly, the voltage of the first power source ELVDD may flow through the second transistor M2 and the third transistor M3 to the second node N2 until the voltage of the second node N2 rises sufficiently to turn off the second transistor M2, i.e., until the voltage rises to the voltage of the first power source ELVDD minus the threshold voltage of the second transistor M2. Therefore, the storage capacitor Cst may be charged with a voltage corresponding to the first reference voltage Vref1 minus the voltage of the first power source ELVDD plus the threshold voltage of the second transistor M2. The voltage of the first reference voltage Vref1 may be the same as that of the first power source ELVDD, in which case the storage capacitor Cst may be charged with a voltage corresponding to the threshold voltage of the second transistor M2.

**[0035]** At the beginning of a third time period T3, the scan signal supplied to the (i-1)-th scan line Si-1 may go

high. Further, during the third time period T3, the emission control signal supplied to the emission control line Ei may go low. The scan signal supplied to the i-th scan line Si may be maintained high. When the scan signal supplied to the (i-1)-th scan line Si-1 is high, the third transistor M3 and the fourth transistor M4 may be turned off, and when the emission control signal supplied to the emission control line Ei is low, the fifth transistor M5 may be turned on.

**[0036]** During a fourth time period T4, the scan signal supplied to the (i-1)-th scan line Si-1 may be maintained high, and the scan signal supplied to the i-th scan line Si may be low. When the scan signal supplied to the i-th scan line Si is low, the first transistor M1 and the sixth transistor M6 may be turned on, and the seventh transistor M7 may be turned off. When the first transistor M1 is turned on, the data signal supplied to the data line Di may be provided to the first node N1 through the first transistor M1. Thus, a voltage of the first node N1 may be reduced from a voltage of the reference voltage Vref1 to a voltage of the data signal. Further, a voltage of the second node N2 set in a floating state may be reduced corresponding to the reduction in voltage of the first node N1. The reduced voltage applied to the gate of the second transistor M2 supplies a predetermined current to the OLED through the fifth transistor M5, in correspondence with the voltage at the second node N2. Thus, a predetermined current may be supplied to the OLED. Further, the voltage present at the OLED may be supplied to the third node N3 through the sixth transistor M6. Accordingly, during the fourth time period T4, when the voltage of the first node N1 changes corresponding to the data signal DATA, the third node N3 may be set to a voltage applied to the OLED.

**[0037]** Next, during a fifth time period T5, the scan signal supplied to the i-th scan line Si may transition high, turning off the first transistor M1 and the sixth transistor M6, and turning on the seventh transistor M7. When the seventh transistor M7 is turned on, a voltage of the third node N3 may be changed to a voltage of the second reference voltage Vref2. As the voltage of the third node N3 is changed from the voltage present at the OLED to a voltage of the second reference voltage Vref2, the voltage of the first node N1 may also change accordingly in response to the voltage change of the third node N3.

**[0038]** When the voltage of the first node N1 changes, the voltage of the second node N2 may also change. The second transistor M2 may supply an electric current, corresponding to the voltage applied to the gate electrode thereof, from the first power source ELVDD to the second power source ELVSS through the OLED. The OLED may generate light of predetermined luminance corresponding to the electric current supplied from the second transistor M2. Further, if the OLED degrades over time, its resistance may increase. As the OLED degrades, the voltage present at the OLED may increase in view of the increased resistance of the OLED.

**[0039]** As the OLED degrades, the change in voltage

at the third node N3 in response to the operation of the seventh transistor M7 may be lessened. In particular, as the OLED degrades, the voltage of the OLED that is supplied to the third node N3 may be increased, which causes the change in voltage at the third node N3 in response to the operation of the seventh transistor M7 to be less than it would be if the OLED were not degraded.

**[0040]** When the change in voltage at the third node N3 is small, voltage changes at the first and second nodes N1 and N2 are also reduced. Accordingly, the amount of electric current supplied to the OLED from the second transistor M2 is increased for a given data signal. Thus, according to embodiments, as the OLED degrades, the amount of electric current supplied to the OLED from the second transistor M2 may be increased, thereby avoiding reductions in luminance due to degradation of the OLED.

**[0041]** As described above, in a circuit for an OLED, a display using the same, and associated methods, as the OLED is degraded, a lower voltage may be supplied to the gate electrode of the drive transistor, so that the luminance deterioration due to the degradation of the organic light emitting diode can be compensated.

### Claims

1. A pixel (140) comprising an OLED and a pixel circuit (142) for driving the OLED, wherein the pixel circuit (142) comprises
  - a first transistor (M1) for passing a data signal in response to an i-th scan signal and having a first electrode coupled to a data line and a second electrode coupled to a first node (N1), and a gate electrode coupled to an i-th scan line (Si) for the i-th scan signal, the first node (N1) being adapted to capacitively store a data signal transferred by the first transistor (M1);
  - a second transistor (M2) having a first electrode coupled to a first power source (ELVDD) for providing a first power supply voltage and a gate electrode coupled to a second node (N2);
  - a third transistor (M3) having a first electrode coupled to the gate electrode of the second transistor (M2), a second electrode coupled to a second electrode of the second transistor (M2), and a gate electrode coupled to an (i-1)-th scan line;
  - a fourth transistor (M4) having a first electrode coupled to a first reference voltage source (Vref1), a second electrode coupled to the first node (N1), and a gate electrode coupled to the (i-1)-th scan line;
  - a fifth transistor (M5) having a first electrode coupled to the second electrode of the second transistor (M2), a second electrode coupled to the anode of the OLED, and a gate electrode coupled to an i-th emission control line; and
  - a storage capacitor (Cst) having a first electrode coupled to the first node (N1) and a second electrode coupled to the second node (N2);
2. The pixel as claimed in claim 1, wherein the compensator (144) includes:
  - a feedback capacitor (Cfb) having a first electrode coupled to the first node (N1) and a second electrode coupled to a third node (N3);
  - a sixth transistor (M6) having a first electrode coupled to the first input, a second electrode coupled to the third node (N3), and a gate electrode coupled to the control input; and
  - a seventh transistor (M7) having a first electrode coupled to a second reference voltage source (Vref2), a second electrode coupled to the third node (N3), and a gate electrode coupled to the control input.
3. The pixel as claimed in claim 2, wherein the sixth transistor (M6) is adapted to be turned on by the i-th scan signal and the seventh transistor (M7) is adapted to be turned off by the i-th scan signal.
4. The pixel as claimed in one of claims 2 or 3, wherein a voltage of the third node (N3) is set to the sensed anode voltage when the sixth transistor (M6) is turned on, and the voltage of the third node (N3) is increased from the sensed anode voltage to the voltage of the second reference voltage source (Vref2) when the seventh transistor (M7) is turned on.
5. The pixel as claimed in one of claims 2 through 4, wherein the feedback capacitor (Cfb) is adapted to transfer a voltage change of the third node (N3) to the first node.
6. The pixel as claimed in claim 2 or in claim 2 and one of the claims 3 through 5, wherein the voltage of the second reference voltage source (Vref2) is set to the first power supply voltage.
7. The pixel as claimed in one of the preceding claims, wherein the voltage of the first reference voltage source (Vref1) is set to the first power supply voltage.
8. An organic light emitting display (100), comprising:
  - a scan driver (110) coupled to a plurality of scan lines (S1...Sn) and a plurality of emission control lines (E1...En);

a data driver (120) coupled to a plurality of data lines (D1...Dm); and  
 a plurality of pixels (140) coupled to respective ones of the scan lines (S1...Sn), the emission control lines (E1...Em), and the data lines (D1...Dn),

**characterised in that** the pixels (140) are pixels (140) according to one of the preceding claims.

9. The organic light emitting display as claimed in claim 8, wherein the scan driver (110) is adapted to supply the i-th scan signal to the i-th scan line (Si) and the i-th emission control signal to the i-th emission control line (Ei) to overlap with each other during a partial time period.

10. The organic light emitting display as claimed in claim 8, wherein the scan driver (110) is adapted to supply the i-th emission control signal to the i-th emission control line (Ei) after a predetermined time after supplying the (i-1)-th scan signal to the (i-1)-th scan line.

11. A method for driving an organic light emitting display (100), comprising:

initializing a gate electrode of a drive transistor (M2) during an initial time period while a low scan signal is supplied to an (i-1)-th scan line (Si-1);  
 supplying a high emission control signal to an i-th emission control line (Ei) after the initial time period and maintaining the high emission control signal while the low scan signal is supplied to the (i-1)-th scan line (Si-1) in order to charge a storage capacitor (Cst) with a voltage corresponding to a threshold voltage of the drive transistor (M2);  
 charging the storage capacitor (Cst) with a voltage corresponding to a data signal while a low scan signal is supplied to an i-th scan line (Si); and  
 controlling a voltage of the gate electrode of the drive transistor (M2) in correspondence with degradation of an OLED.

12. The method as claimed in claim 11, wherein initializing the gate electrode of the drive transistor (M2) during the initial time period includes applying a first reference voltage to a first electrode of the storage capacitor (Cst), a second electrode of the storage capacitor (Cst) being coupled to the gate electrode of the drive transistor (M2).

13. The method as claimed in one of the claims 11 or 12, wherein controlling the voltage of the gate electrode of the drive transistor (M2) includes:

providing a voltage of an anode electrode of the

OLED to a first terminal of a feedback capacitor (Cfb) while the low scan signal is supplied to the i-th scan line (Si); and  
 increasing a voltage of the first terminal of the feedback capacitor (Cfb) while a high scan signal is supplied to the i-th scan line (Si), wherein:

a second terminal of the feedback capacitor (Cfb) is coupled to a first terminal of the storage capacitor (Cst), and  
 a second terminal of the storage capacitor (Cst) is coupled to the gate electrode of the drive transistor (M2).

14. The method as claimed in one of the claims 11 through 13, wherein controlling the voltage of the gate electrode of the drive transistor further includes reducing a voltage change of the first terminal of the feedback capacitor (Cfb) in correspondence with increasing resistance of the OLED.

15. The method as claimed in one of the claims 11 through 14, wherein controlling the voltage of the gate electrode of the drive transistor (M2) further includes reducing the voltage of a gate electrode of the drive transistor (M2) in correspondence with the reduction in the voltage change of the first terminal of the feedback capacitor (Cfb).

16. The method as claimed in one of the claims 11 through 15, wherein controlling the voltage of the gate electrode of the drive transistor (M2) further includes increasing an electric current supplied to the OLED by the drive transistor (M2) in correspondence with the reduction in the voltage of the gate electrode of the drive transistor (M2).

17. The method as claimed in one of the claims 11 through 16, wherein controlling the voltage of the gate electrode of the drive transistor (M2) further includes increasing the voltage of the first terminal of the feedback capacitor (Cfb) to a second reference voltage while the high scan signal is supplied to the i-th scan line (Si).

18. The method as claimed in one of the claims 11 through 17, wherein: a scan signal having a low pulse is supplied to the (i-1)-th scan line and subsequently supplied to the i-th scan line, an emission control signal having a high pulse is supplied to the i-th emission control line, the emission control pulse on the i-th emission control line transitions high after the scan signal on the (i-1)-th scan line transitions low, and the emission control pulse on the i-th emission control line transitions low after the scan signal on the (i-1)-th scan line transitions high.

FIG. 1

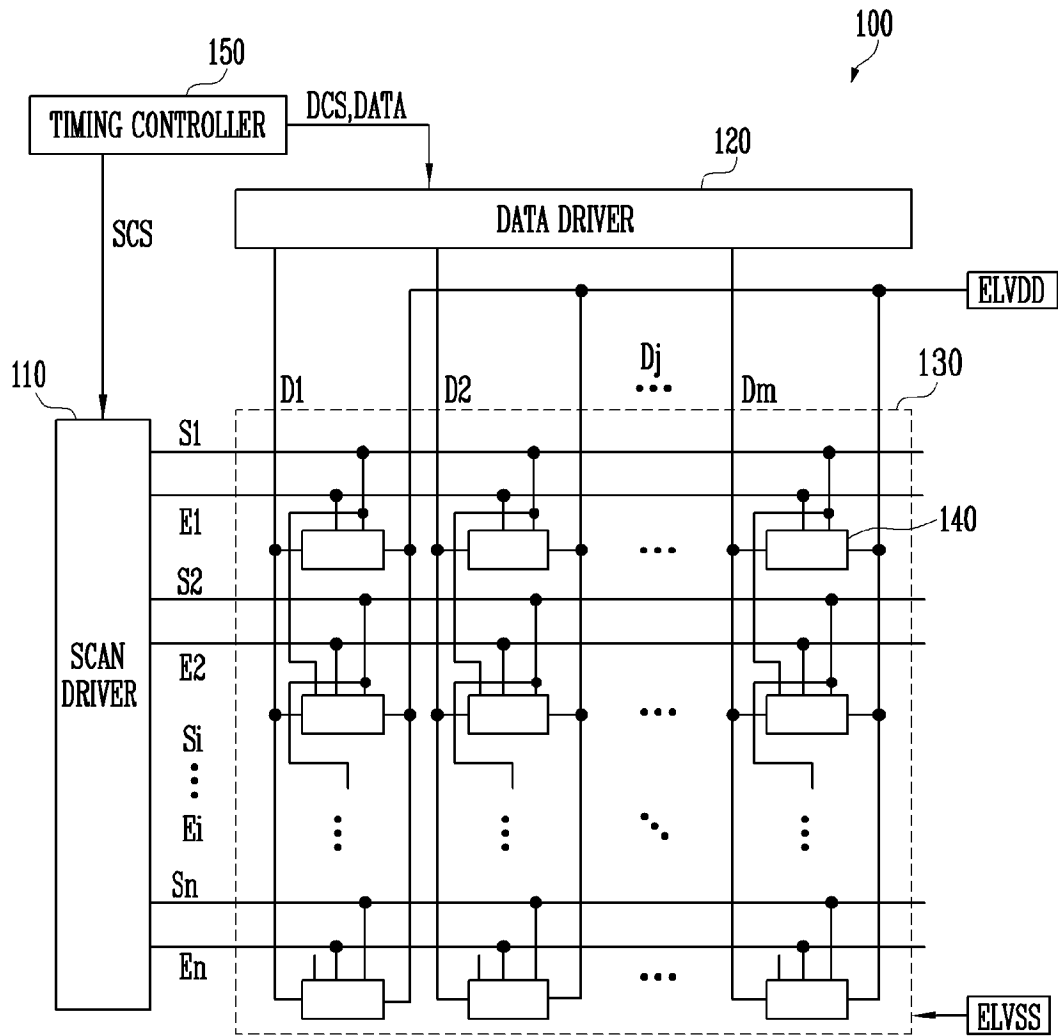

FIG. 2

140

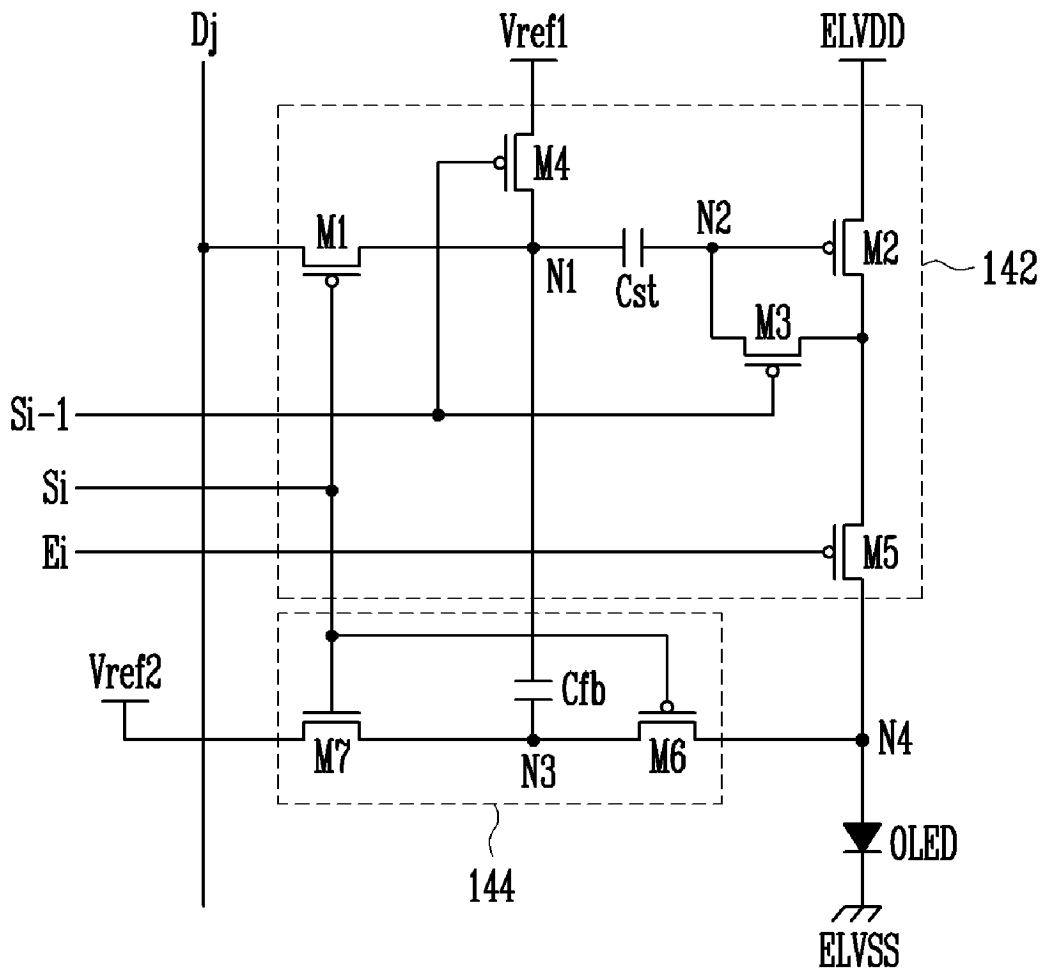
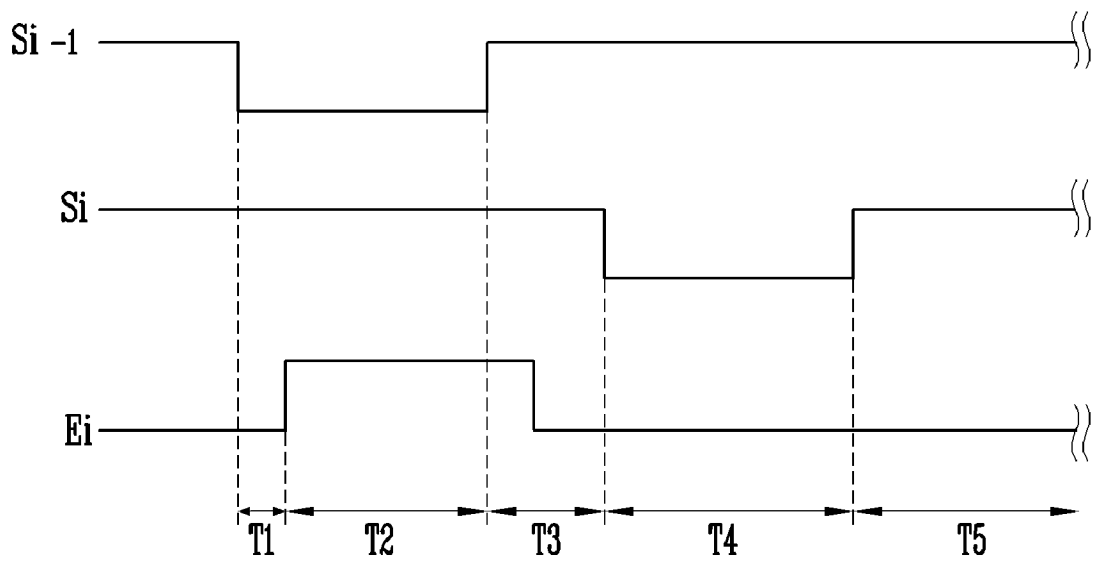

FIG. 3





DOCUMENTS CONSIDERED TO BE RELEVANT			
Category	Citation of document with indication, where appropriate, of relevant passages	Relevant to claim	CLASSIFICATION OF THE APPLICATION (IPC)
X	EP 1 708 162 A (SONY CORP [JP]) 4 October 2006 (2006-10-04) * paragraphs [0001], [0040] - [0045] * * figures 8A-8B * -----	1,7-16, 18	INV. G09G3/32
X	US 2006/022305 A1 (YAMASHITA ATSUHIRO [JP]) 2 February 2006 (2006-02-02) * paragraphs [0016], [0483] - [0496] * * figures 38,39 * -----	11-16,18	
A	US 2005/179625 A1 (CHOI JOON-HOO [KR] ET AL) 18 August 2005 (2005-08-18) * paragraphs [0103] - [0132] * * figures 6-8 * -----	1,11	
The present search report has been drawn up for all claims			TECHNICAL FIELDS SEARCHED (IPC)
			G09G
Place of search		Date of completion of the search	Examiner
The Hague		11 June 2008	Ladiray, Olivier
CATEGORY OF CITED DOCUMENTS			
X : particularly relevant if taken alone Y : particularly relevant if combined with another document of the same category A : technological background O : non-written disclosure P : intermediate document		T : theory or principle underlying the invention E : earlier patent document, but published on, or after the filing date D : document cited in the application L : document cited for other reasons ..... & : member of the same patent family, corresponding document	

2  
EPC FORM 1503 03.82 (F04C01)

**ANNEX TO THE EUROPEAN SEARCH REPORT  
ON EUROPEAN PATENT APPLICATION NO.**

EP 08 15 2784

This annex lists the patent family members relating to the patent documents cited in the above-mentioned European search report. The members are as contained in the European Patent Office EDP file on The European Patent Office is in no way liable for these particulars which are merely given for the purpose of information.

11-06-2008

Patent document cited in search report		Publication date	Patent family member(s)	Publication date
EP 1708162	A	04-10-2006	CN 1886773 A	27-12-2006
			JP 2005164893 A	23-06-2005
			WO 2005055184 A1	16-06-2005
			KR 20070000406 A	02-01-2007
			TW 280543 B	01-05-2007
			US 2007091029 A1	26-04-2007
-----				
US 2006022305	A1	02-02-2006	JP 2006309104 A	09-11-2006
-----				
US 2005179625	A1	18-08-2005	NONE	
-----				

EPO FORM P0459

For more details about this annex : see Official Journal of the European Patent Office, No. 12/82

专利名称(译)	像素，使用其的有机发光显示器以及相关方法		
公开(公告)号	<a href="#">EP1970885A1</a>	公开(公告)日	2008-09-17
申请号	EP2008152784	申请日	2008-03-14
[标]申请(专利权)人(译)	三星斯笛爱股份有限公司		
申请(专利权)人(译)	三星SDI CO., LTD.		
当前申请(专利权)人(译)	三星移动显示器有限公司.		
[标]发明人	KIM YANG WAN SAMSUNG SDI CO LTD		
发明人	KIM, YANG-WAN, SAMSUNG SDI CO., LTD.		
IPC分类号	G09G3/32		
CPC分类号	G09G3/3233 G09G2300/0819 G09G2300/0852 G09G2320/043 G09G2320/045		
代理机构(译)	hengelhaupt, Jürgen		
优先权	1020070025063 2007-03-14 KR		
外部链接	<a href="#">Espacenet</a>		

摘要(译)

一种用于驱动OLED的像素，包括耦合在数据线和第一节点之间的第一晶体管，第一晶体管通过第i扫描线上的低信号导通，第二晶体管耦合在第一电源和第一晶体管之间第五晶体管，第三晶体管，耦合在第二晶体管的栅极和第二晶体管的电极之间，第二晶体管的电极耦合到第五晶体管，第三晶体管在第(i-1)扫描时由低信号导通线，第四晶体管，耦合在第一参考电压和第一节点之间，第四晶体管由第(i-1)扫描线上的低信号导通，存储电容器耦合在第一节点和第二节点之间和控制第二节点的电压的补偿器，其对应于OLED的劣化。

