



(12) EUROPEAN PATENT APPLICATION

(43) Date of publication: 28.06.2006 Bulletin 2006/26 (51) Int Cl.: G09G 3/32^(2006.01)

(21) Application number: 05112583.9

(22) Date of filing: 21.12.2005

(84) Designated Contracting States:
AT BE BG CH CY CZ DE DK EE ES FI FR GB GR
HU IE IS IT LI LT LU LV MC NL PL PT RO SE SI
SK TR
Designated Extension States:
AL BA HR MK YU

(72) Inventor: Choi, Sang Moo
Legal & IP Team
Yongin
Gyeonggi-do (KR)

(30) Priority: 24.12.2004 KR 2004112517

(74) Representative: Hengelhaupt, Jürgen et al
Anwaltskanzlei
Gulde Hengelhaupt Ziebig & Schneider
Wallstrasse 58/59
10179 Berlin (DE)

(71) Applicant: Samsung SDI Co., Ltd.
Suwon-si
Gyeonggi-do (KR)

(54) Organic light emitting diode display and driving method thereof

(57) An organic light emitting diode display and a driving method thereof, has an image displayed with uniform brightness. The method of driving a organic light emitting diode display, includes dividing one frame into

one or more sub-frames, and supplying scan signals in sequence to some of plural scan lines provided in a pixel portion per sub-frame. The scan lines receiving the scan signals are differently set per sub-frame. With this configuration, an image is displayed with uniform brightness.

FIG. 4

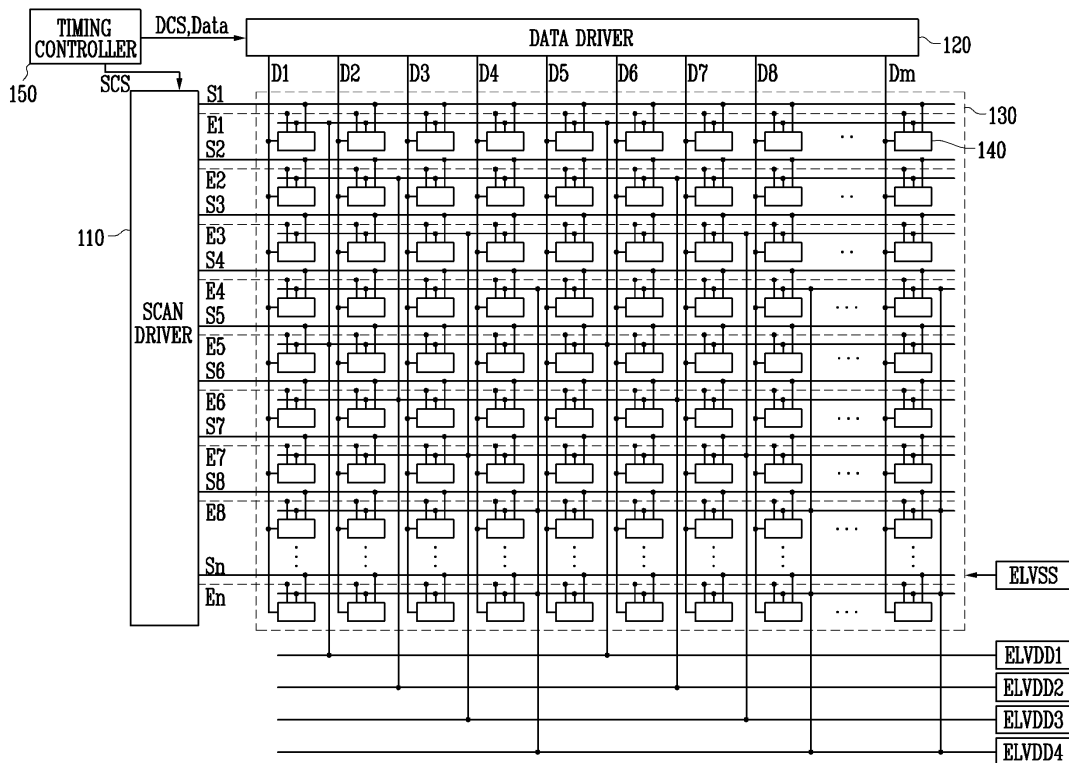
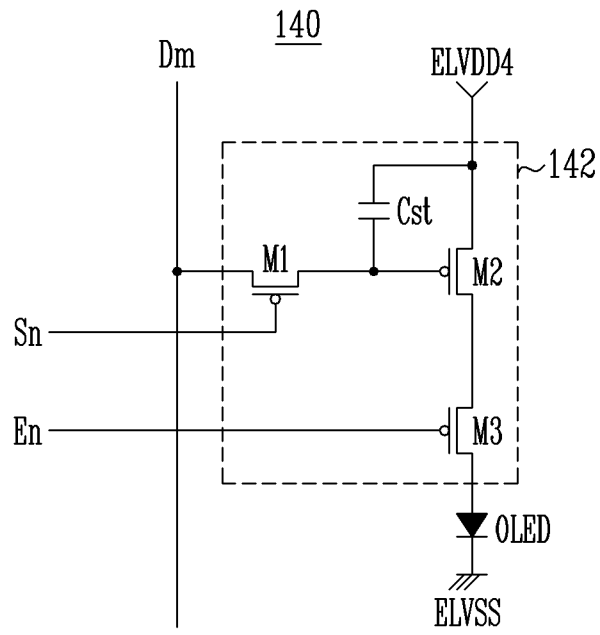

FIG. 6



Description

CLAIM OF PRIORITY

[0001] This application makes reference to, incorporates the same herein, and claims all benefits accruing under 35 U.S.C. §119 from an application for LIGHT EMITTING DISPLAY AND DRIVING METHOD THEREOF earlier filed in the Korean Intellectual Property Office on 24 December 2004 and there duly assigned Serial No. 2004-112517.

BACKGROUND OF THE INVENTION

1. Field of the Invention

[0002] The present invention relates to an organic light emitting diode display and a driving method thereof, and more particularly, to an organic light emitting diode display and a driving method thereof, in which an image is displayed with uniform brightness.

2. Description of the Related Art

[0003] Various flat panel displays have recently been developed as alternatives to a relatively heavy and bulky cathode ray tube (CRT) display. The flat panel display includes a liquid crystal display (LCD), a field emission display (FED), a plasma display panel (PDP), an organic light emitting diode display (OLED), *etc.*

[0004] Among the flat panel displays, the organic light emitting diode display can emit light for itself by electron-hole recombination. Such an organic light emitting diode display has advantages in that response time is relatively fast and power consumption is relatively low. Generally, the organic light emitting diode display employs a transistor provided in each pixel for supplying current corresponding to a data signal to a light emitting device, thereby allowing the light emitting device to emit light.

[0005] FIG. 1 illustrates a conventional organic light emitting diode display.

[0006] Referring to FIG. 1, a conventional organic light emitting diode display includes a pixel portion 30 including a plurality of pixels 40 formed in a region defined by intersection of scan lines S 1 through Sn and data lines D 1 through Dm; a scan driver 10 to drive the scan lines S 1 through Sn; a data driver 20 to drive the data lines D1 through Dm; and a timing controller 50 to control the scan driver 10 and the data driver 20.

[0007] The scan driver 10 generates scan signals in response to a scan control signal SCS from the timing controller 50, and supplies the scan signals to the scan lines S1 through Sn in sequence. Further, the scan driver 10 generates emission control signals in response to the scan control signal SCS, and supplies the emission control signals to emission control lines E1 through En in sequence.

[0008] The data driver 20 generates data signals in

response to data control signal DCS from the timing controller 50, and supplies the data signals to the data lines D 1 through Dm. At this time, the data driver 20 supplies the data signals corresponding to one horizontal line to the data lines D 1 through Dm per one horizontal period.

[0009] The timing controller 50 generates the data control signal DCS and the scan control signal SCS corresponding to an external synchronization signal. The data control signal DCS and the scan control signal SCS are supplied from the timing controller 50 to the data driver 20 and the scan driver 10, respectively. Further, the timing controller 50 rearranges external data and supplies it to the data driver 20.

[0010] The pixel portion 30 receives first power ELVDD and second power ELVSS from an external power source, and supplies them to the respective pixels 40. When the first power ELVDD and the second power ELVSS are applied to the pixels 40, each pixel 40 displays an image corresponding to the received data signal. Here, emission time of each pixel 40 is controlled corresponding to the emission control signal.

[0011] Like the scan signals, the emission control signals are supplied to the 1st through nth emission control lines En, in sequence. Here, every pixel 40 included in the pixel portion 30 does not emit light for a short time while the emission control signal is not supplied.

[0012] However, the first power ELVDD applied to the pixel portion 30 varies according to how many pixels 40 emit light, i.e., according to a pattern and brightness of an image displayed on the pixel portion 30. That is, the first power ELVDD supplied per frame is differently loaded to the pixels 40 according to how many pixels 40 emit light. For example, when relatively many pixels 40 emit light during one frame, the relatively high first power ELVDD is loaded to the pixels 40. On the other hand, when relatively small pixels 40 emit light during one frame, the relatively low first power ELVDD is loaded to the pixels 40. Therefore, voltage difference corresponding to the pattern of an image arises between the pixels 40 receiving the first power ELVDD 40, and thus there is a problem in that the image is displayed with non-uniform brightness. Further, due to voltage drop, the voltage of the first power ELVDD is differently applied to the pixels 40 according to the positions of the pixels 40 formed in the pixel portion 30, and thus the image is displayed with non-uniform brightness.

SUMMARY OF THE INVENTION

[0013] Accordingly, it is an aspect of the present invention to provide an organic light emitting diode display and a driving method thereof, in which an image is displayed with uniform brightness.

[0014] It is another aspect of the present invention to provide an organic light emitting diode display and a driving method thereof, in which one frame is divided into a plurality of sub-frames, and pixels receiving data signals during a sub-frame are maintained in a non-emission

state, so that pixels are respectively charged with desired voltages, and thus an image is displayed with uniform brightness corresponding to the data signal.

[0015] It is yet another aspect of the present invention to provide an organic light emitting diode display and driving technique that is efficient, easy to implement, cost effective.

[0016] The foregoing and/or other aspects of the present invention are achieved by providing an organic light emitting diode display capable of dividing one frame into one or more sub-frames, the organic light emitting diode display includes: a plurality of scan lines; a plurality of data lines; a plurality of pixels connected to the scan lines and the data lines; a scan driver to supply scan signals in sequence to some of the scan lines per sub-frame; a data driver to supply data signals corresponding to the scan signals; and a plurality of first power sources connected to anode electrodes of light emitting devices provided in the pixels and provided as the same number as the sub-frames, with the scan lines receiving the scan signals are differently set per sub-frame.

[0017] According to an aspect of the invention, the scan driver supplies the scan signals to $1/i$ scan lines among the scan lines provided in the pixel portion per sub-frame (where, i is the number of sub-frames corresponding to one frame). Further, the data driver supplies the data signal to the pixels connected to the pixels receiving the scan signals during each sub-frame.

[0018] Another aspects of the present invention are achieved by providing a method of driving an organic light emitting diode display, including: dividing one frame into one or more sub-frames; and supplying scan signals in sequence to some of plural scan lines provided in a pixel portion per sub-frame, with the scan lines receiving the scan signals are differently set per sub-frame.

[0019] According to an aspect of the invention, the scan signals are supplied to $1/i$ scan lines among the scan lines provided in the pixel portion per sub-frame (where, i is the number of sub-frames corresponding to one frame). Further, data signals are supplied to the pixels receiving the scan signals during each sub-frame. Preferably, the method further includes controlling the pixels receiving the data signals do not emit light during the sub-frame for receiving the data signal.

[0020] Still another aspects of the present invention are achieved by providing a method of driving an organic light emitting diode display, including: dividing one frame into three or more sub-frames; and setting some pixels of a pixel portion as a non-emission state and the rest of pixels as an emission state per sub-frame.

[0021] According to an aspect of the invention, data signals are supplied to the pixels set as the non-emission state during each sub-frame. Here, $1/i$ pixels among the pixels provided in the pixel portion do not emit light per sub-frame (where, i is the number of sub-frames corresponding to one frame). Further, the pixels set as the non-emission state are different per sub-frame of one frame.

[0022] Yet other aspects of the present invention are achieved by providing a method of driving an organic light emitting diode display, including: dividing one frame into one or more sub-frames; setting the number of first power sources connected to an anode electrode of a light emitting device provided in a pixel to be equal to the number of sub-frames; and supplying data signals to some pixels provided in a pixel portion per sub-frame, with the pixels receiving the data signals do not emit light during each sub-frame.

[0023] According to an aspect of the invention, the data signals are supplied to $1/i$ pixels among the pixels provided in the pixel portion per sub-frame (where, i is the number of sub-frames corresponding to one frame). Here, the pixels provided in the pixel portion do not emit light during one or more sub-frames among i sub-frames, and emit light during the rest of sub-frames. Further, the pixel portion includes i first power sources, and the pixels that do not emit light during the same sub-frame are connected to the same first power source among i first power sources.

BRIEF DESCRIPTION OF THE DRAWINGS

[0024] A more complete appreciation of the invention, and many of the attendant advantages thereof, will be readily apparent as the same becomes better understood by reference to the following detailed description when considered in conjunction with the accompanying drawings in which like reference symbols indicate the same or similar components, wherein:

[0025] FIG. 1 is a layout diagram of a conventional organic light emitting diode display;

[0026] FIG. 2 illustrates a driving method for an organic light emitting diode display according to an embodiment of the present invention;

[0027] FIG. 3 shows pixels that do not emit light depending on the driving method illustrated in FIG. 2;

[0028] FIG. 4 is a layout diagram of an organic light emitting diode display according to a first embodiment of the present invention;

[0029] FIG. 5 shows waveforms of scan signals supplied from a scan driver of FIG. 4;

[0030] FIG. 6 is a circuit diagram of a pixel according to an embodiment of the present invention;

[0031] FIG. 7 is a layout diagram of an organic light emitting diode display according to a second embodiment of the present invention;

[0032] FIG. 8 shows waveforms of control signal supplied to transistors of FIG. 7;

[0033] FIG. 9 is a layout diagram of an organic light emitting diode display according to a third embodiment of the present invention;

[0034] FIG. 10 shows waveforms of emission control signal supplied to emission control lines of FIG. 9;

[0035] FIG. 11 is a layout diagram of an organic light emitting diode display according to a fourth embodiment of the present invention;

[0036] FIG. 12 is a layout diagram of an organic light emitting diode display according to a fifth embodiment of the present invention;

[0037] FIG. 13 is a circuit diagram of a pixel according to another embodiment of the present invention; and

[0038] FIG. 14 illustrates a driving method for the pixel of FIG. 13.

DETAILED DESCRIPTION OF PREFERRED EMBODIMENTS

[0039] Hereinafter, preferable embodiments according to the present invention will be described with reference to the accompanying drawings, wherein the preferred embodiments of the present invention are provided to be readily understood by those skilled in the art.

[0040] FIG. 2 illustrates a driving method for an organic light emitting diode display according to an embodiment of the present invention.

[0041] Referring to FIG. 2, an organic light emitting diode display according to an embodiment of the present invention is driven dividing one frame F into a plurality of sub-frames SF. For example, one frame F according to an embodiment of the present invention is divided into i sub-frames SF (where, i is a natural number). During each sub-frame SF, some pixels do not emit light, and the rest of the pixels emit light. Here, some pixels that do not emit light receive data signals during the sub-frame SF.

[0042] According to an embodiment of the present invention, the pixels that receive the data signal, i.e., the pixels that do not emit light are set differently from each other during each sub-frame SF of one frame. For example, the pixels, which receive the data signal during the 1st sub-frame 1SF, do not receive the data signal during the 2nd sub-frame 2SF through the i th sub-frame i SF. That is, the pixels according to an embodiment of the present invention do not emit light during one sub-frame among i sub-frames SF, and emit light during the rest of sub-frames. Alternatively, the pixels according to an embodiment of the present invention may not emit light during one or more sub-frames.

[0043] Hence, the number of pixels that do not emit light during each sub-frame is set as $1/i$ of the total number of pixels. For example, if one frame F is divided into four sub-frames and the total number of pixels provided in a pixel portion is 4,000, one thousand pixels do not emit light during each sub-frame. Meanwhile, if one frame is divided into two sub-frames, a time during which the pixels do not emit light becomes longer, so that a flicker is likely to arise. Therefore, it is preferable that one frame is divided into three or more sub-frames.

[0044] FIG. 3 shows pixels which do not emit light depending on the driving method illustrated in FIG. 2. For the sake of convenience and example, it will be herein below assumed that the pixel portion includes n scan lines S 1 through S n and one frame is divided into four sub-frames SF.

[0045] Referring to FIG. 3, one frame F is divided into four sub-frames, and thus pixels connected to different scan lines are set as a non-emission state per sub-frame. In other words, the pixels corresponding to non-emission are set differently per sub-frame.

[0046] During the 1st sub-frame 1 SF, the pixels connected to the 1st scan line S1, the 5th scan line S5 ($(i+1)$ th scan line), the 9th scan line S9 ($(2i+1)$ th scan line), ..., the $(n-3)$ th scan line S $n-3$ are set as the non-emission state. Further, the data signals are supplied during the 1st sub-frame 1 SF to the pixels connected to the 1st scan line S1, the 5th scan line S5, the 9th scan line S9, ..., the $(n-3)$ th scan line S $n-3$.

[0047] During the 2nd sub-frame 2SF, the pixels connected to the 2nd scan line S2, the 6th scan line S6 ($(i+2)$ th scan line), the 10th scan line S10 ($(2i+2)$ th scan line), ..., the $(n-2)$ th scan line S $n-2$ are set as the non-emission state. Further, the data signals are supplied during the 2nd sub-frame 2SF to the pixels connected to the 2nd scan line S2, the 6th scan line S6, the 10th scan line S10, ..., the $(n-2)$ th scan line S $n-2$.

[0048] During the 3rd sub-frame 3SF, the pixels connected to the 3rd scan line S3, the 7th scan line S7 ($(i+3)$ th scan line), the 11th scan line S11 ($(2i+3)$ th scan line), ..., the $(n-1)$ th scan line S $n-1$ are set as the non-emission state. Further, the data signals are supplied during the 3rd sub-frame 3SF to the pixels connected to the 3rd scan line S3, the 7th scan line S7, the 11th scan line S11 ($(2i+3)$ th scan line), ..., the $(n-1)$ th scan line S $n-1$.

[0049] During the 4th sub-frame 4SF, the pixels connected to the 4th scan line S4, the 8th scan line S8 ($2i$ th scan line), the 12th scan line S12 ($3i$ th scan line), ..., the n th scan line S n are set as the non-emission state. Further, the data signals are supplied during the 3rd sub-frame 3SF to the pixels connected to the 4th scan line S4, the 8th scan line S8, the 12th scan line S12, ..., the n th scan line S n .

[0050] Thus, according to an embodiment of the present invention, one frame F is divided into a plurality of sub-frames SF, and the data signals are supplied to the pixels different per sub-frame. Here, the pixels receiving the data signal are set as the non-emission state during each sub-frame SF. As the pixels receiving the data signal are set as the non-emission state, the pixels display an image with uniform brightness, which will be described later.

[0051] FIG. 4 is a layout diagram of an organic light emitting diode display according to a first embodiment of the present invention.

[0052] Referring to FIG. 4, an organic light emitting diode display according to a first embodiment of the present invention includes a pixel portion 130 including a plurality of pixels 140 formed in a region intersected by scan lines S 1 through S n and data lines D 1 through D m ; a scan driver 110 to driver the scan lines S 1 through S n ; a data driver 120 to drive the data lines D 1 through D m ; and a timing controller 150 to control the scan driver 110 and the data driver 120.

[0053] The timing controller 150 generates a data control signal DCS and a scan control signal SCS in response to external synchronization signals, and supplies the data control signal DCS and the scan control signal SCS to the data driver 120 and the scan driver 110, respectively. Further, the timing controller 150 rearranges external data Data and supplies it to the data driver 120.

[0054] The scan driver 110 generates scan signals in response to the scan control signals SCS from the timing controller 150, and supplies them to the scan lines S. Here, the scan driver 110 sequentially supplies the scan signals to the scan lines S connected to the pixels 140 that receives the data during each sub-frame, i.e., which are set as the non-emission state. For example, in a case where the pixel portion 130 is formed with n scan lines S1 through Sn, the scan driver 110 supplies the scan signals to n/i scan lines S during each sub-frame.

[0055] That is, the scan driver 110 supplies the scan signals to some scan lines S in sequence during each sub-frame. Here, the scan lines S receiving the scan signals are differently set per each sub-frame. For example, when the pixels are set as the non-emission state during the sub-frame as shown in FIG. 3, the scan driver 110 supplies the scan signals as shown in FIG. 5.

[0056] In more detail, the scan driver 110 supplies the scan signals to the 1st scan line S1, the 5th scan line S5, the 9th scan line S9, ..., the (n-3)th scan line Sn-3 in sequence during the 1st sub-frame 1 SF. Further, the scan driver 110 supplies the scan signals to the 2nd scan line S2, the 6th scan line S6, the 10th scan line S10, ..., the (n-2)th scan line Sn-2 in sequence during the 2nd sub-frame 2SF. Also, the scan driver 110 supplies the scan signals to the 3rd scan line S3, the 7th scan line S7, the 11th scan line S11, ..., the (n-1)th scan line Sn-1 in sequence during the 3rd sub-frame 3SF. Further, the scan driver 110 supplies the scan signals to the 4th scan line S4, the 8th scan line S8, the 12th scan line S12, ..., the (n)th scan line Sn in sequence during the 4th sub-frame 4SF.

[0057] The data driver 120 generates data signals in response to the data control signals DCS from the timing controller 150, and supplies them to the data lines D1 through Dm in sequence. Here, the data driver 120 supplies the data signals corresponding to the scan signals supplied from the scan driver 110. That is, the data driver 120 supplies the data signals to the pixels 130 which do not emit light during each sub-frame.

[0058] For example, the data driver 120 supplies the data signals to the pixels 140 connected to the 1st scan line S1, the 5th scan line S5, the 9th scan line S9, ..., the (n-3)th scan line Sn-3 in correspondence to the scan signals supplied in sequence during the 1st sub-frame 1 SF. Further, the scan driver 110 supplies the data signals to the pixels 140 connected to the 2nd scan line S2, the 6th scan line S6, the 10th scan line S10, ..., the (n-2)th scan line Sn-2 in correspondence to the scan signals supplied in sequence during the 2nd sub-frame 2SF. Also, the scan driver 110 supplies the data signals to the pixels 140

connected to the 3rd scan line S3, the 7th scan line S7, the 11th scan line S11, ..., the (n-1)th scan line Sn-1 in correspondence to the scan signals supplied in sequence during the 3rd sub-frame 3SF. Further, the scan driver 110 supplies the data signals to the pixels 140 connected to the 4th scan line S4, the 8th scan line S8, the 12th scan line S12, ..., the (n)th scan line Sn in correspondence to the scan signals supplied in sequence during the 4th sub-frame 4SF.

[0059] The pixel portion 130 receives external first power ELVDD and external second power ELVSS through a first power line ELVDD and a second power line ELVSS, respectively. Here, the first power line ELVDD is divided into a plurality of power lines corresponding to the number of sub-frames. For example, in a case where one frame is divided into four sub-frames, the first power line ELVDD is divided into a first divided power line ELVDD1, a second divided power line ELVDD2, a third divided power line ELVDD3, and a fourth divided power line ELVDD4. At this time, the first, second, third and fourth divided power ELUDD1, ELVDD2, ELVDD3 and ELVDD4 are set to have the same voltage level as the first power ELVDD.

[0060] The first divided power line ELUDD1 is connected to the pixels that receive the data signals during the 1st sub-frame. The second divided power line ELVDD2 is connected to the pixels that receive the data signals during the 2nd sub-frame. The third divided power line ELVDD3 is connected to the pixels that receive the data signals during the 3rd sub-frame. The fourth divided power line ELVDD 1 is connected to the pixels that receive the data signals during the 4th sub-frame.

[0061] The pixels 140, connected between one of the first through fourth divided power lines ELVDD1 through ELVDD4 and a second power line ELVSS, receive the data signals during one of the plurality of sub-frames, and display an image corresponding to the data signal during the rest of the sub-frames.

[0062] FIG. 6 is a circuit diagram of a pixel according to an embodiment of the present invention. For the sake of convenience, the pixel connected to the mth data line Dm and the nth scan line Sn will be exemplarily described. Hence, the pixel shown in FIG. 6 is connected with the fourth divided power ELVDD4.

[0063] Referring to FIG. 6, each pixel 140 according to an embodiment of the present invention includes a pixel circuit 142 connected with the light emitting device OLED, the data line Dm, the scan line Sn, and the emission control line En, and controlling the light emitting device OLED.

[0064] The light emitting device OLED includes an anode electrode connected to the pixel circuit 142 and a cathode electrode connected to the second power line ELVSS. Here, the light emitting device OLED emits light corresponding to current supplied from the pixel circuit 142.

[0065] The pixel circuit 142 includes a first transistor M1, a second transistor M2, a third transistor M3 and a

capacitor Cst. The first transistor M1 is turned on when the scan signal is supplied to the nth scan line Sn. When the first transistor M1 is turned on, the data signal is supplied from the data line Dm to the capacitor Cst. At this time, the capacitor Cst is charged with voltage corresponding to the data signal when the first transistor M1 is turned on.

[0066] The second transistor M2 supplies current corresponding to the voltage charged in the capacitor Cst to the third transistor M3. Here, the third transistor M3 is connected between the second transistor M2 and the light emitting device OLED. Further, the third transistor M3 is turned off for a period of time while the emission control signal is supplied, and turned on the rest of periods.

[0067] As shown in FIG. 6, the pixel 140 is maintained as the non-emission state during the 4th sub-frame 4SF while receiving the data signal. Substantially, all pixels 140 connected to the fourth divided power line ELVDD4 do not emit light during the 4th sub-frame 4SF. Then, the current does not flow in the fourth divided power line ELVDD4 during the 4th sub-frame 4SF, so that there is no voltage drop in the fourth divided power line ELVDD4. As there is no voltage drop in the fourth divided power line ELVDD4 during the 4th sub-frame 4SF, the capacitors C of the pixels 140 receiving the data signals during the 4th sub-frame 4SF are charged with the voltage correctly corresponding to the data signal without loss.

[0068] Meanwhile, while the pixels 140 receiving the data signal during the 4th sub-frame 4SF emit light, a predetermined current flows in the fourth divided power line ELVDD4 and thus the voltage drop arises in the fourth divided power line ELVDD4. As the voltage drop arises in the fourth divided power line ELVDD4, voltage applied to a gate electrode of the second transistor M2 connected to the fourth divided power line ELVDD4 via the capacitor Cst varies corresponding to the voltage drop in the fourth divided power line ELVDD4. In other words, the coupling effect of the capacitor Cst causes the voltage applied to the gate electrode of the second transistor M2 to vary corresponding to the voltage drop in the fourth divided power line ELVDD4. Then, voltage difference between the gate electrode and a source electrode of the second transistor M2 is uniformly maintained regardless of the voltage drop in the fourth divided power ELVDD4. Thus, according to an embodiment of the present invention, an image is displayed with uniform brightness depending on the voltage charged in the capacitor Cst.

[0069] According to an embodiment of the present invention, one frame is divided into one or more sub-frames, and the pixels receiving the data signal during the sub-frame are maintained in the non-emission state, thereby displaying an image with uniform brightness. Here, various methods can be used to maintain the pixels in the non-emission state.

[0070] For example, the voltage levels of the first divided power ELUDD 1, the second divided power ELVDD2, the third divided power ELVDD3 and the fourth

divided power ELVDD4 are used to set the pixel 140 as the non-emission state.

[0071] During the 1st sub-frame 1SF, the voltage level of the first divided power ELVDD1 can be lowered to make the light emitting device OLED to not emit light. For example, the first divided power ELVDD1 can be set to have the same voltage level as the second power ELVSS during the 1st sub-frame 1SF. Thus, the first divided power ELVDD1 is lowered during the 1st sub-frame 1SF, so that the pixels 140 connected to the first divided power line ELVDD 1 do not emit light.

[0072] During the 2nd sub-frame 2SF, the voltage level of the second divided power ELVDD2 can be lowered to make the light emitting device OLED to not emit light. For example, the second divided power ELVDD2 can be set to have the same voltage level as the second power ELVSS during the 2nd sub-frame 2SF. In the meantime, the voltage level of the first divided power ELVDD 1 is increased during the 2nd sub-frame 2SF, so that the light emitting device OLED emits light.

[0073] Likewise, the voltage level of third divided power ELVDD3 is lowered during the 3rd sub-frame, and the voltage level of the fourth divided power ELVDD4 is lowered during the 4th sub-frame, thereby maintaining some pixels in the non-emission state during a predetermined sub-frame.

[0074] FIG. 7 is a layout diagram of an organic light emitting diode display according to a second embodiment of the present invention.

[0075] Referring to FIG. 7, the organic light emitting diode display according to the second embodiment of the present invention additionally includes first through fourth transistors M11 through M14 respectively connected to the first through fourth divided power lines ELVDD1 through ELVDD4 in order to maintain some pixels in the non-emission state during a predetermined sub-frame.

[0076] The first transistor M11 is connected to the first divided power line ELUDD1. Here, the first transistor M11 is turned off during the 1st sub-frame in response to an external first control signal CS1 (refer to FIG. 8), and turned on during the rest of frames 2SF through 4SF. Thus, the pixels connected to the first divided power line ELVDD1 do not emit light during the 1st sub-frame 1 SF.

[0077] The second transistor M12 is connected to the second divided power line ELVDD2. Here, the second transistor M12 is turned off during the 2nd sub-frame in response to an external second control signal CS2 (refer to FIG. 8), and turned on during the rest of frames 1 SF, 3 SF and 4SF. Thus, the pixels connected to the second divided power line ELVDD2 do not emit light during the 2nd sub-frame 2SF.

[0078] The third transistor M13 is connected to the third divided power line ELVDD3. Here, the third transistor M13 is turned off during the 3rd sub-frame in response to an external third control signal CS3 (refer to FIG. 8), and turned on during the rest of the frames 1SF, 2SF and 4SF. Thus, the pixels connected to the third divided power line ELVDD3 do not emit light during the 3rd sub-frame

3SF.

[0079] The fourth transistor M14 is connected to the fourth divided power line ELVDD4. Here, the fourth transistor M14 is turned off during the 4th sub-frame in response to an external fourth control signal CS4 (refer to FIG. 8), and turned on during the rest of the frames 1SF through 3SF. Thus, the pixels connected to the fourth divided power line ELVDD4 do not emit light during the 4th sub-frame 4SF.

[0080] FIG. 9 is a layout diagram of an organic light emitting diode display according to a third embodiment of the present invention.

[0081] Referring to FIG. 9, the organic light emitting diode display according to the third embodiment of the present invention includes four emission control lines E1 through E4 corresponding to the four sub-frames.

[0082] The first emission control line E1 is connected to the pixels receiving the data signal during the 1st sub-frame 1SF. Here, the first emission control line E1 receives an emission control signal (refer to FIG. 10) during the 1st sub-frame 1SF. Then, the third transistor M3 connected to the first emission control line E1 is turned off. That is, the pixels receiving the data signals during the 1st sub-frame 1 SF are set as the non-emission state by the emission control signal supplied to the first emission control line E1.

[0083] The second emission control line E2 is connected to the pixels receiving the data signal during the 2nd sub-frame 2SF. Here, the second emission control line E2 receives the emission control signal (refer to FIG. 10) during the 2nd sub-frame 2SF. Then, the second transistor M2 connected to the second emission control line E2 is turned off. That is, the pixels receiving the data signals during the 2nd sub-frame 2SF are set as the non-emission state by the emission control signal supplied to the second emission control line E2.

[0084] The third emission control line E3 is connected to the pixels receiving the data signal during the 3rd sub-frame 3SF. Here, the third emission control line E3 receives the emission control signal (refer to FIG. 10) during the 3rd sub-frame 3SF. Then, the third transistor M3 connected to the third emission control line E3 is turned off. That is, the pixels receiving the data signals during the 3rd sub-frame 3SF are set as the non-emission state by the emission control signal supplied to the third emission control line E3.

[0085] The fourth emission control line E4 is connected to the pixels receiving the data signal during the 4th sub-frame 4SF. Here, the fourth emission control line E4 receives the emission control signal (refer to FIG. 10) during the 4th sub-frame 4SF. Then, the fourth transistor M4 connected to the fourth emission control line E4 is turned off. That is, the pixels receiving the data signals during the 4th sub-frame 4SF are set as the non-emission state by the emission control signal supplied to the fourth emission control line E4.

[0086] Further, according to an embodiment of the present invention, the pixel can be controlled to have the

non-emission state, using the second power ELVSS.

[0087] FIG. 11 is a layout diagram of an organic light emitting diode display according to a fourth embodiment of the present invention.

[0088] Referring to FIG. 11, in the organic light emitting diode display according to the fourth embodiment of the present invention, the second power line ELVSS can be divided into a fifth divided power ELUSS1, sixth divided power ELVSS2, seventh divided power ELVSS3, and eighth divided power ELVSS4. Here, the fifth through eighth divided power ELUSS1 through ELVSS4 have the same voltage level as the second power ELVSS. That is, the voltage levels of the fifth through eighth divided power lines ELUSS1 through ELVSS4, connected to the cathode electrode of the light emitting device OLED, are set to be lower than those of the first through fourth divided power lines ELVDD1 through ELVDD4, connected to the anode electrode of the light emitting device OLED.

[0089] The fifth divided power line ELUSS1 is connected to the pixels receiving the data signal during the 1st sub-frame 1 SF. The sixth divided power line ELVSS2 is connected to the pixels receiving the data signal during the 2nd sub-frame 2SF. The seventh divided power line ELVSS3 is connected to the pixels receiving the data signal during the 3rd sub-frame 3SF. The eighth divided power ELVSS4 is connected to the pixels receiving the data signal during the 4th sub-frame.

[0090] In the organic light emitting diode display according to the fourth embodiment of the present invention, the fifth through eighth divided power ELVSS1 through ELVSS4 are used for controlling the pixels to have the non-emission state during the respective sub-frames.

[0091] During the 1st sub-frame 1 SF, the voltage level of the fifth divided power ELVSS1 is increased to make the light emitting device OLED to not emit light. For example, the fifth divided power ELVSS1 can be increased to have the same voltage level as the first divided power ELVDD1 during the 1st sub-frame 1SF. Thus, the fifth divided power ELVSS is increased during the 1st sub-frame 1SF, so that the pixels connected to the fifth divided power line ELVSS1 do not emit light.

[0092] During the 2nd sub-frame 2SF, the voltage level of the sixth divided power ELVSS2 is increased to make the light emitting device OLED to not emit light. For example, the sixth divided power ELVSS2 can be increased to have the same voltage level as the second divided power ELVDD2 during the 2nd sub-frame 2SF. Thus, the sixth divided power ELVSS2 is increased during the 2nd sub-frame 2SF, so that the pixels connected to the sixth divided power line ELVSS2 do not emit light.

[0093] During the 3rd sub-frame 3SF, the voltage level of the seventh divided power ELVSS3 is increased to make the light emitting device OLED to not emit light. For example, the seventh divided power ELVSS3 can be increased to have the same voltage level as the third divided power ELVDD3 during the 3rd sub-frame 3SF. Thus, the seventh divided power ELVSS3 is increased

during the 3rd sub-frame 3SF, so that the pixels connected to the seventh divided power line ELVSS3 do not emit light.

[0094] During the 4th sub-frame 4SF, the voltage level of the eighth divided power ELVSS4 is increased to make the light emitting device OLED to not emit light. For example, the seventh divided power ELVSS4 can be increased to have the same voltage level as the fourth divided power ELVDD4 during the 4th sub-frame 4SF. Thus, the eighth divided power ELVSS4 is increased during the 4th sub-frame 4SF, so that the pixels connected to the eighth divided power line ELVSS4 do not emit light.

[0095] FIG. 12 is a layout diagram of an organic light emitting diode display according to a fifth embodiment of the present invention.

[0096] Referring to FIG. 12, the organic light emitting diode display according to the fifth embodiment of the present invention additionally includes first through fourth transistors M21 through M24 respectively connected to the fifth through eighth divided power lines ELVSS1 through ELVSS4 in order to maintain some pixels in the non-emission state during a predetermined sub-frame.

[0097] The first transistor M21 is connected to the fifth divided power line ELVSS 1. Here, the first transistor M21 is turned off during the 1st sub-frame 1 SF in response to an external first control signal CS1 (refer to FIG. 12), and turned on during the rest frames 2SF through 4SF. Thus, the pixels connected to the fifth divided power line ELVSS 1 do not emit light during the 1st sub-frame 1 SF.

[0098] The second transistor M22 is connected to the sixth divided power line ELVSS2. Here, the second transistor M22 is turned off during the 2nd sub-frame 2SF in response to an external second control signal CS2 (refer to FIG. 12), and turned on during the rest frames 1 SF, 3 SF and 4SF. Thus, the pixels connected to the sixth divided power line ELVSS2 do not emit light during the 2nd sub-frame 2SF.

[0099] The third transistor M23 is connected to the seventh divided power line ELVSS3. Here, the third transistor M23 is turned off during the 3rd sub-frame 3SF in response to an external third control signal CS3 (refer to FIG. 12), and turned on during the rest frames 1SF, 2SF and 4SF. Thus, the pixels connected to the third divided power line ELVSS3 do not emit light during the 3rd sub-frame 3SF.

[0100] The fourth transistor M24 is connected to the eighth divided power line ELVSS4. Here, the fourth transistor M24 is turned off during the 4th sub-frame 4SF in response to an external fourth control signal CS4 (refer to FIG. 12), and turned on during the rest frames 1 SF through 3SF. Thus, the pixels connected to the eighth divided power line ELVSS4 do not emit light during the 4th sub-frame 4SF.

[0101] As described above, according to an embodiment of the present invention, various methods can be used for making some pixels to not emit light during a predetermined sub-frame. Here, the pixels in the non-

emission state receive the data signals during a predetermined sub-frame, so that an image is displayed with uniform brightness. Meanwhile, the pixels according to an embodiment of the present invention can have various configurations. For example, the pixel 140 according to an embodiment of the present invention can be configured as shown in FIG. 13 to display an image corresponding to the data signal regardless of the threshold voltage of a transistor.

[0102] FIG. 13 is a circuit diagram of a pixel according to another embodiment of the present invention. For the sake of convenience, the pixel connected to the mth data line Dm and the nth scan line Sn will be exemplarily described. Hence, the pixel shown in FIG. 13 is connected with the fourth divided power ELVDD4.

[0103] Referring to FIG. 13, each pixel 140 according to an embodiment of the present invention includes a pixel circuit 142 connected with the light emitting device OLED, the data line Dm, the scan line Sn, and the emission control line En, and controlling the light emitting device OLED.

[0104] The light emitting device OLED includes the anode electrode connected to the pixel circuit 142 and the cathode electrode connected to the second power line ELVSS. Here, the light emitting device OLED emits light corresponding to current supplied from the pixel circuit 142.

[0105] The pixel circuit 142 includes first and sixth transistors M1 and M6 connected between the fourth divided power line ELVDD4 and the data line Dm; a third transistor M3 connected to the light emitting device OLED and the emission control line En; a second transistor M2 connected between the third transistor M3 and a first node N1; a fifth transistor M5 having first and gate electrodes connected to the first node N1 and a second electrode connected to a gate electrode of the second transistor M2; and a fourth transistor M4 connected between the gate and second electrodes of the second transistor M2. Here, the first electrode is used as one of the source and drain electrodes, and the second electrode is used as the other one.

[0106] The first transistor M 1 has the first electrode connected to the data line Dm, and the second electrode connected to the first node N1. Further, the first transistor M 1 has the gate electrode connected to the scan line Sn. Here, the first transistor M 1 is turned on in response to the scan signal supplied through the scan line Sn, and supplies the data signal from the data line Dm to the first node N1.

[0107] The second transistor M2 has the first electrode connected to the first node N1, and the gate electrode connected to a capacitor Cst. Further, the second transistor M2 has the second electrode connected to the first electrode of the third transistor M3. Here, the second transistor M2 supplies current corresponding to voltage charged in the capacitor Cst to the light emitting device OLED.

[0108] The third transistor M3 has the first electrode

connected to the second electrode of the second transistor M2, and the gate electrode connected to the emission control line En. Further, the third transistor M3 has the second electrode connected to the light emitting device OLED. Here, the third transistor M3 is turned on while the emission control signal is not supplied through the emission control line En, and supplies the current from the second transistor M2 to the light emitting device OLED.

[0109] The fourth transistor M4 has the second electrode connected to the gate electrode of the second transistor M2, and the first electrode connected to the second electrode of the second transistor M2. Further, the fourth transistor M4 has the gate electrode connected to the scan line Sn. Here, the fourth transistor M4 is turned on in response to the scan signal supplied through the scan line Sn, and controls the fourth transistor M4 to be connected like a diode.

[0110] The fifth transistor M5 has the gate and first electrodes connected to the first node N1, and the second electrode connected to the gate electrode of the second transistor M2. Here, the fifth transistor M5 is connected like a diode, and supplies an initialization voltage from the data line Dm to the gate electrode of the second transistor M2.

[0111] The sixth transistor M6 has the second electrode connected to the first node N1, and the first electrode connected to the fourth divided power line ELVDD4. Further, the sixth transistor M6 has the gate electrode connected to the emission control line En. Here, the sixth transistor M6 is turned on while the emission control signal is not supplied, and electrically connects the first power line ELVDD with the first node N1.

[0112] Herein below, operations of the pixel 142 will be described with reference to FIG. 14. First, the scan signal is supplied to the scan line Sn, and the initialization voltage Vi is supplied to the data lines D.

[0113] When the scan signal is supplied to the nth scan line Sn, the first transistor M1 and the fourth transistor M4 are turned on. As the first transistor M1 is turned on, the initialization voltage Vi is supplied from the data line Dm to the first node N1. Then, the fifth transistor M5 having the diode-like-connection is turned on by the initialization voltage Vi supplied to the first node N1, and thus the initialization voltage Vi is supplied to the gate terminal of the second transistor M2.

[0114] When the initialization voltage Vi is supplied to the gate electrode of the second transistor M2, the gate electrode of the second transistor M2 and the capacitor Cst are initialized. In other words, the gate electrode of the second transistor M2 is initialized by the initialization voltage Vi having a voltage level lower than the lowest voltage level of the data signal supplied from the data driver 120. Then, the second transistor M2 is turned on regardless of the voltage level of the data signal supplied to the first node N1.

[0115] After supplying the initialization voltage Vi to the gate electrode of the second transistor M2, a data signal

DS corresponding to a predetermined gray level is supplied to the data line Dm. Then, the data signal Ds is supplied from the data line Dm to the first node N1 via the first transistor M1. At this time, the gate electrode of the second transistor M2 is initialized by the initialization voltage Vi, so that the second transistor M2 is turned on. As the second transistor M2 is turned on, the data signal Ds applied to the first node N1 is supplied to a first terminal of the capacitor Cst via the second and fourth transistors M2 and M4. At this time, the data signal, of which the voltage is lowered by the voltage corresponding to the threshold voltage Vth of the second transistor M2, is supplied to the first terminal of the capacitor Cst, and thus the capacitor Cst is charged with the voltage corresponding to the data signal and the threshold voltage Vth of the second transistor M2.

[0116] In the pixel according to another embodiment of the present invention, the capacitor Cst is charged with the data signal and the voltage corresponding to the threshold voltage Vth, so that an image is displayed with desired brightness. Then, the current corresponding to the voltage charged in the capacitor Cst is supplied to the light emitting device OLED during the rest frames except for the sub-frame supplying the data signal, thereby displaying an image.

[0117] As described above, the present invention provides an organic light emitting diode display and a driving method thereof, in which one frame is divided into a plurality of sub-frames, and pixels receiving data signals during a sub-frame are maintained in a non-emission state, so that pixels are respectively charged with desired voltages. Thus, an image is displayed with uniform brightness corresponding to the data signal.

[0118] Although a few embodiments of the present invention have been shown and described, it would be appreciated by those skilled in the art that changes might be made in this embodiment without departing from the principles and spirit of the invention, the scope of which is defined in the claims and their equivalents.

Claims

1. An organic light emitting diode display capable of dividing one frame into one or more sub-frames, the organic light emitting diode display comprises:

- a plurality of scan lines;
- a plurality of data lines;
- a plurality of pixels connected to said scan lines and said data lines;
- a scan driver to supply scan signals in sequence to at least some of said scan lines per sub-frame;
- a data driver to supply data signals corresponding to said scan signals; and
- a plurality of first power sources connected to anode electrodes of light emitting devices provided in said pixels and provided as the same

- number as the sub-frames,
with the scan lines receiving the scan signals
being differently set per sub-frame.
2. The organic light emitting diode display according to claim 1, wherein said scan driver supplies the scan signals to $1/i$ scan lines among the scan lines provided in the pixel portion per sub-frame, where i is the number of sub-frames corresponding to one frame.
 3. The organic light emitting diode display according to claim 2, wherein said data driver supplies the data signal to the pixels connected to the pixels receiving the scan signals during each sub-frame.
 4. The organic light emitting diode display according to claim 3, wherein the pixel portion comprises i first power sources, and the pixels receiving the data signal during the same sub-frame are connected to the same first power source among i first power sources.
 5. The organic light emitting diode display according to claim 4, wherein said first power source among i first power sources, connected with the pixels receiving the data signal, has a voltage level enough to make the pixels do not emit light during the sub-frame for receiving the data signal.
 6. The organic light emitting diode display according to claim 4, further comprising i transistors connected to i first power sources, respectively.
 7. The organic light emitting diode display according to claim 6, wherein the transistors among i transistors, connected to the pixels receiving the data signal, are turned on during the sub-frame for receiving the data signal, and the rest of the transistors are turned off during the same sub-frame.
 8. The organic light emitting diode display according to claim 3, further comprising i second power sources connected to cathode electrodes of said light emitting devices provided in said pixels.
 9. The organic light emitting diode display according to claim 8, wherein said pixels receiving the data signal during the same sub-frame are connected to the same second power source among i second power sources.
 10. The organic light emitting diode display according to claim 9, wherein said second power source among i second power sources, connected with the pixels receiving the data signal, has a voltage level enough to make the pixels, do not emit light during the sub-frame for receiving the data signal.
 11. The organic light emitting diode display according to claim 9, further comprising i transistors connected to i second power sources, respectively.
 12. The organic light emitting diode display according to claim 11, wherein one transistor among i transistors, connected to said pixels receiving the data signal, is turned on during the sub-frame for receiving the data signal, and the rest of the transistors are turned off during the same sub-frame.
 13. The organic light emitting diode display according to claim 4, wherein each one of the plurality of pixels comprises:
 - a first transistor connected to said scan line and said data line, and controlled by the scan signal;
 - a second transistor to control current to be supplied to said light emitting device in correspondence to the data signal;
 - a capacitor connected to said second transistor and charged with voltage corresponding to the data signal; and
 - a third transistor connected to an emission control line, tuned off for a period while an emission control signal is supplied from said scan driver, and tuned on for the rest of periods.
 14. The organic light emitting diode display according to claim 13, wherein the emission control line is formed in parallel with said scan line, and provided as the same number as i sub-frames.
 15. The organic light emitting diode display according to claim 14, wherein the pixels receiving the data signal during the same sub-frame are connected to the same emission control line.
 16. The organic light emitting diode display according to claim 15, wherein said scan driver supplies an emission control signal to one emission control line among i emission control lines per sub-frame the pixels to control the pixels receiving the data signals to not emit light.
 17. A method of driving an organic light emitting diode display, comprising:
 - dividing one frame into at least one sub-frame;
 - and
 - supplying scan signals in sequence to some of a plurality of scan lines provided in a pixel portion per sub-frame, with the scan lines receiving said scan signals are differently set per sub-frame.
 18. The method according to claim 17, wherein the scan signals are supplied to $1/i$ scan lines among said scan lines provided in the pixel portion per sub-

- frame, where, i is the number of sub-frames corresponding to one frame.
19. The method according to claim 18, wherein data signals are supplied to the pixels receiving the scan signals during each sub-frame. 5
20. The method according to claim 19, further comprising controlling the pixels receiving the data signals do not emit light during the sub-frame for receiving the data signal. 10
21. The method according to claim 20, wherein the controlling of the pixels to not emit light comprises decreasing a voltage level of a power source connected to an anode electrode of a light emitting device provided in each pixel receiving the data signal. 15
22. The method according to claim 20, wherein the controlling of the pixels to not emit light comprises interrupting power supplied from a power source connected to an anode electrode of a light emitting device provided in each pixel receiving the data signal. 20
23. The method according to claim 20, wherein the controlling of the pixels to not emit light comprises turning off a transistor that is provided in each pixel receiving the data signal and controls a point of time for supplying a current flowing in the light emitting device. 25
24. The method according to claim 20, wherein the controlling of the pixels to not emit light comprises increasing a voltage level of a power source connected to a cathode electrode of a light emitting device provided in each pixel receiving the data signal. 30
25. The method according to claim 20, wherein the controlling of the pixels to not emit light comprises interrupting power supplied from a power source connected to a cathode electrode of a light emitting device provided in each pixel receiving the data signal. 35
26. A method of driving an organic light emitting diode display, comprising: 40
- dividing one frame into three or more sub-frames; and
 setting some pixels of a pixel portion as a non-emission state and the rest of the pixels as an emission state per sub-frame. 50
27. The method according to claim 26, wherein data signals are supplied to the pixels set as the non-emission state during each sub-frame. 55
28. The method according to claim 27, wherein $1/i$ pixels among the pixels provided in the pixel portion do not emit light per sub-frame, where, i is the number of sub-frames corresponding to one frame.
29. The method according to claim 28, wherein the pixels set as the non-emission state are different per sub-frame of one frame.
30. The method according to claim 26, wherein the number of pixels set as the emission state is larger than the number of pixels set as the non-emission state.
31. A method of driving an organic light emitting diode display, comprising:
- dividing one frame into one or more sub-frames;
 setting the number of first power sources connected to an anode electrode of a light emitting device provided in a pixel to be equal to the number of sub-frames; and
 supplying data signals to some pixels provided in a pixel portion per sub-frame, with the pixels receiving the data signals do not emit light during each sub-frame.
32. The method according to claim 31, wherein the data signals are supplied to $1/i$ pixels among the pixels provided in the pixel portion per sub-frame, where i is the number of sub-frames corresponding to one frame.
33. The method according to claim 32, wherein the pixels provided in the pixel portion do not emit light during one or more sub-frames among i sub-frames, and emit light during the rest of the sub-frames.
34. The method according to claim 33, wherein the pixel portion comprises i first power sources, and the pixels that do not emit light during the same sub-frame are connected to the same first power source among i first power sources.
35. The method according to claim 34, wherein the pixels that do not emit light during different sub-frames of one frame are connected to different first power sources among i first power sources, respectively.

FIG. 1
PRIOR ART

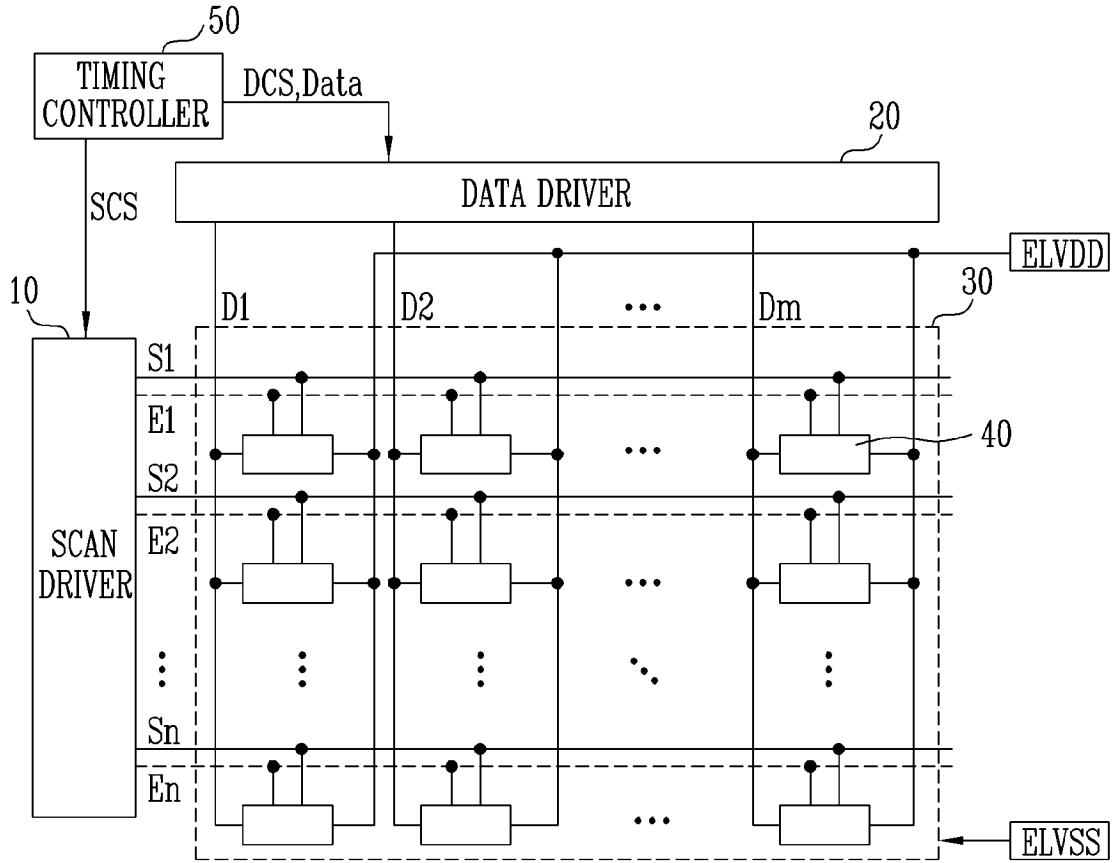

FIG. 2

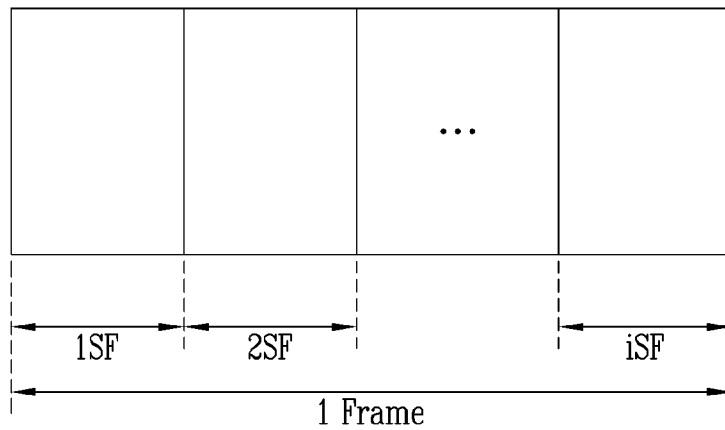

FIG. 3

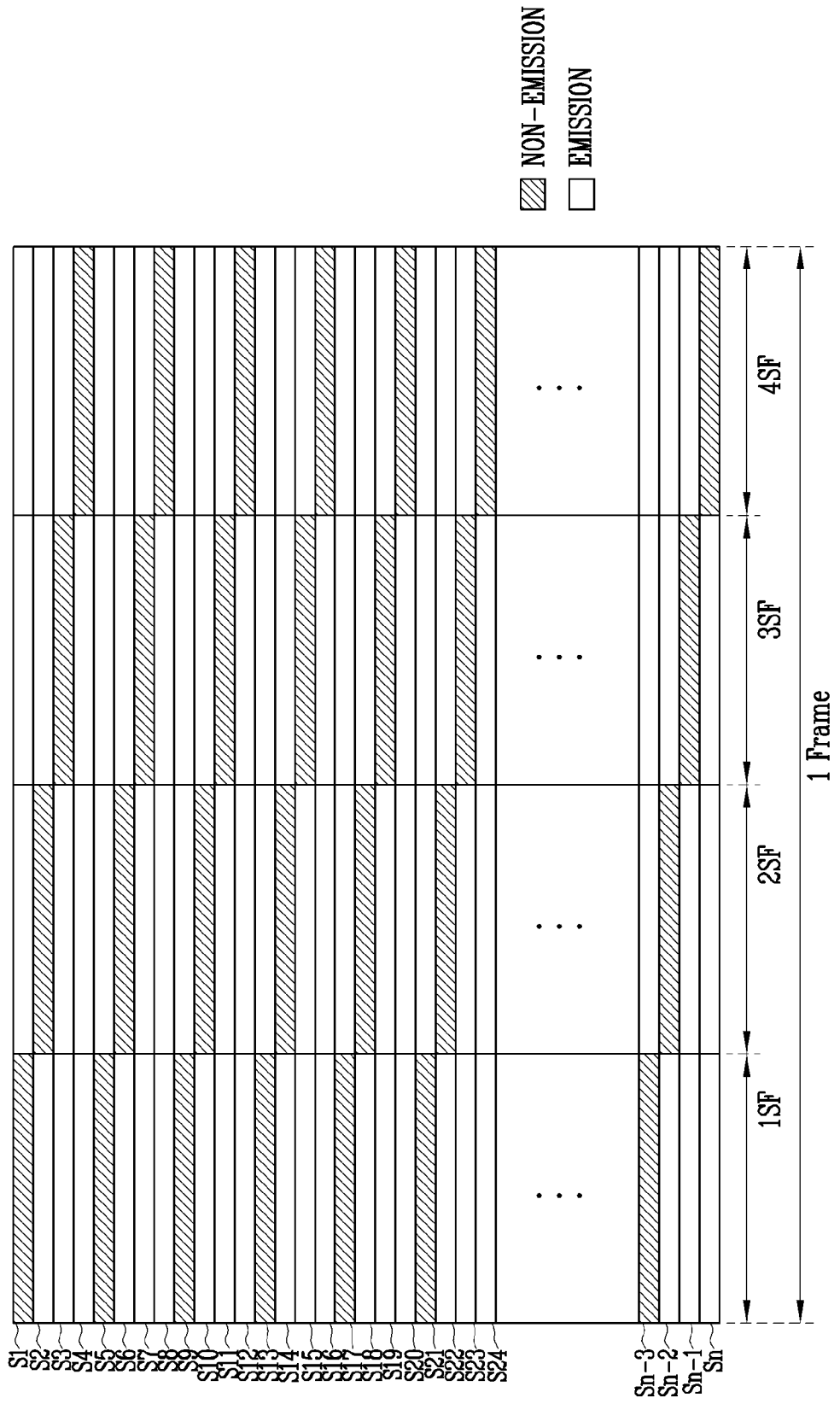

FIG. 4

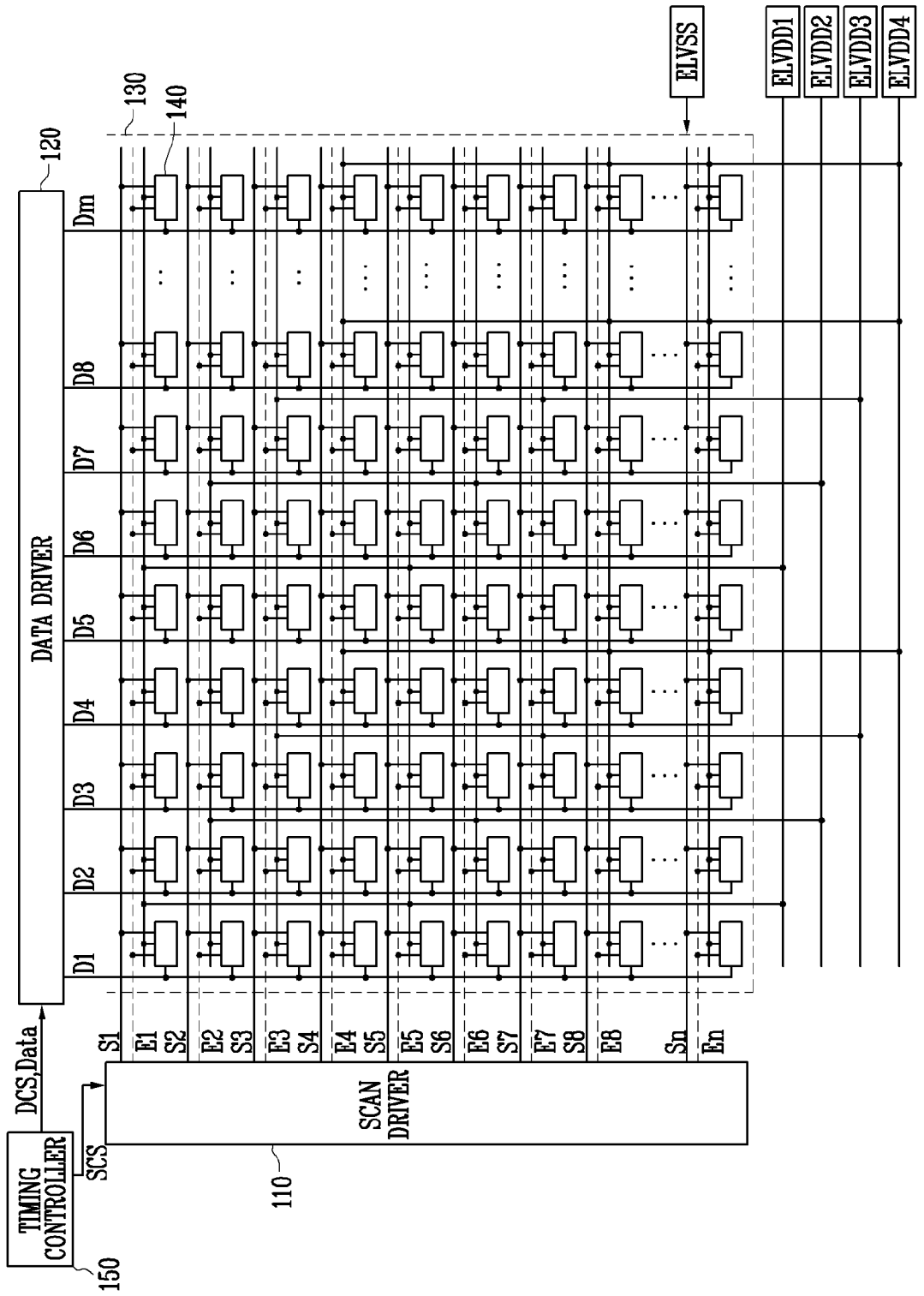

FIG. 5

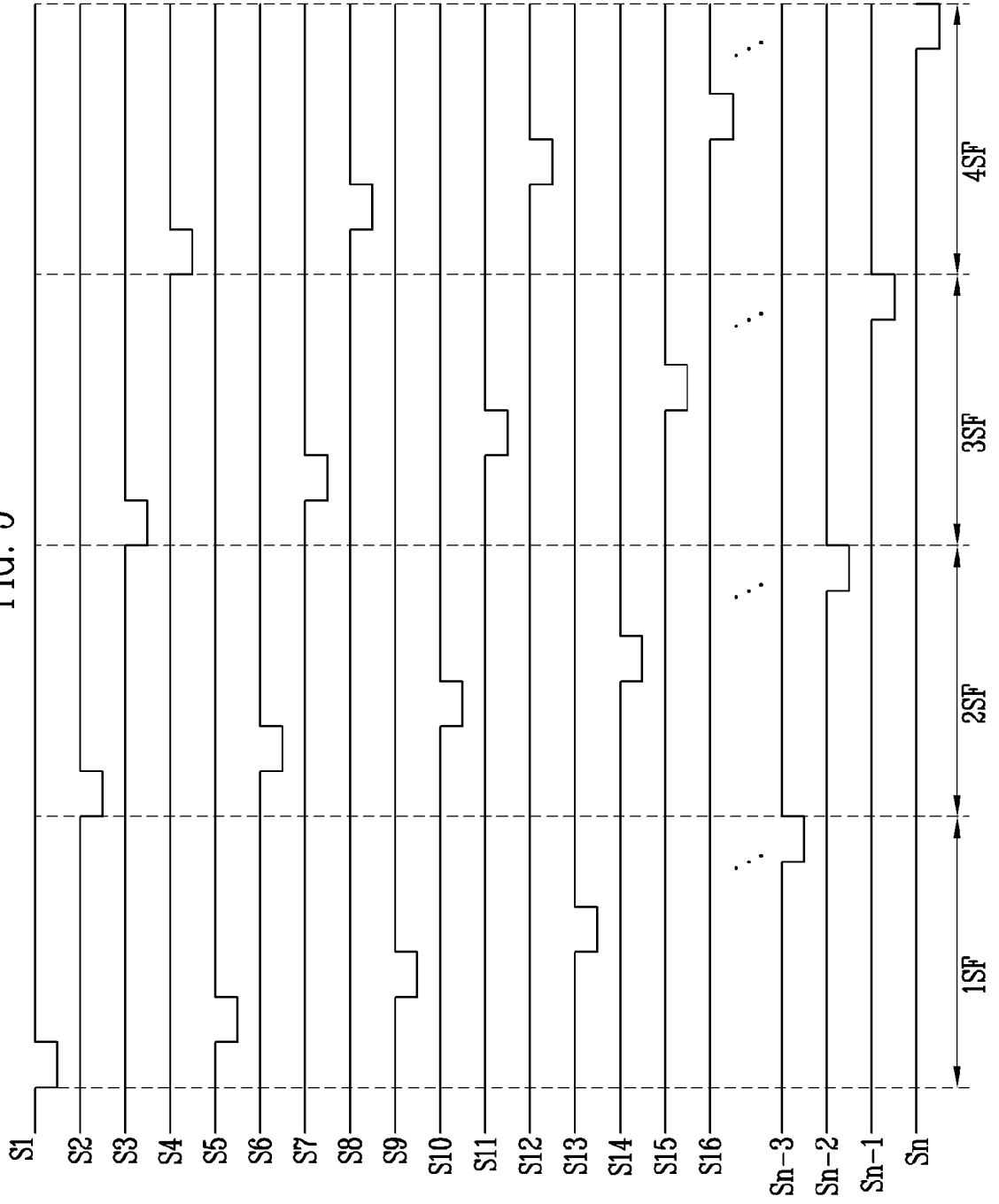

FIG. 6

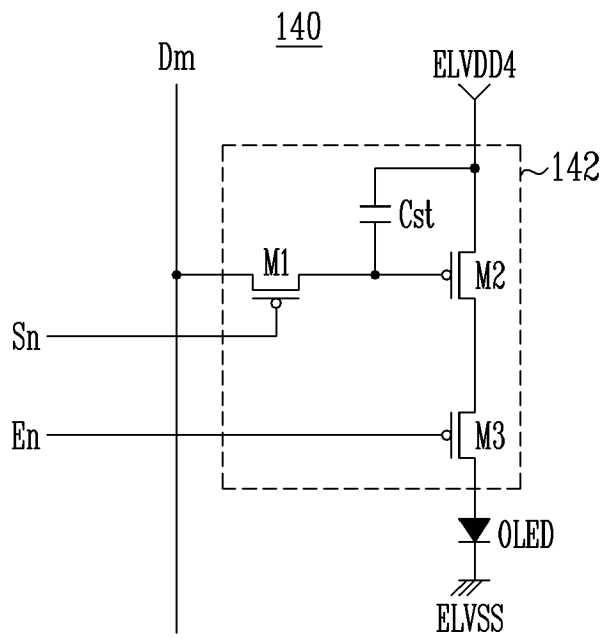

FIG. 7

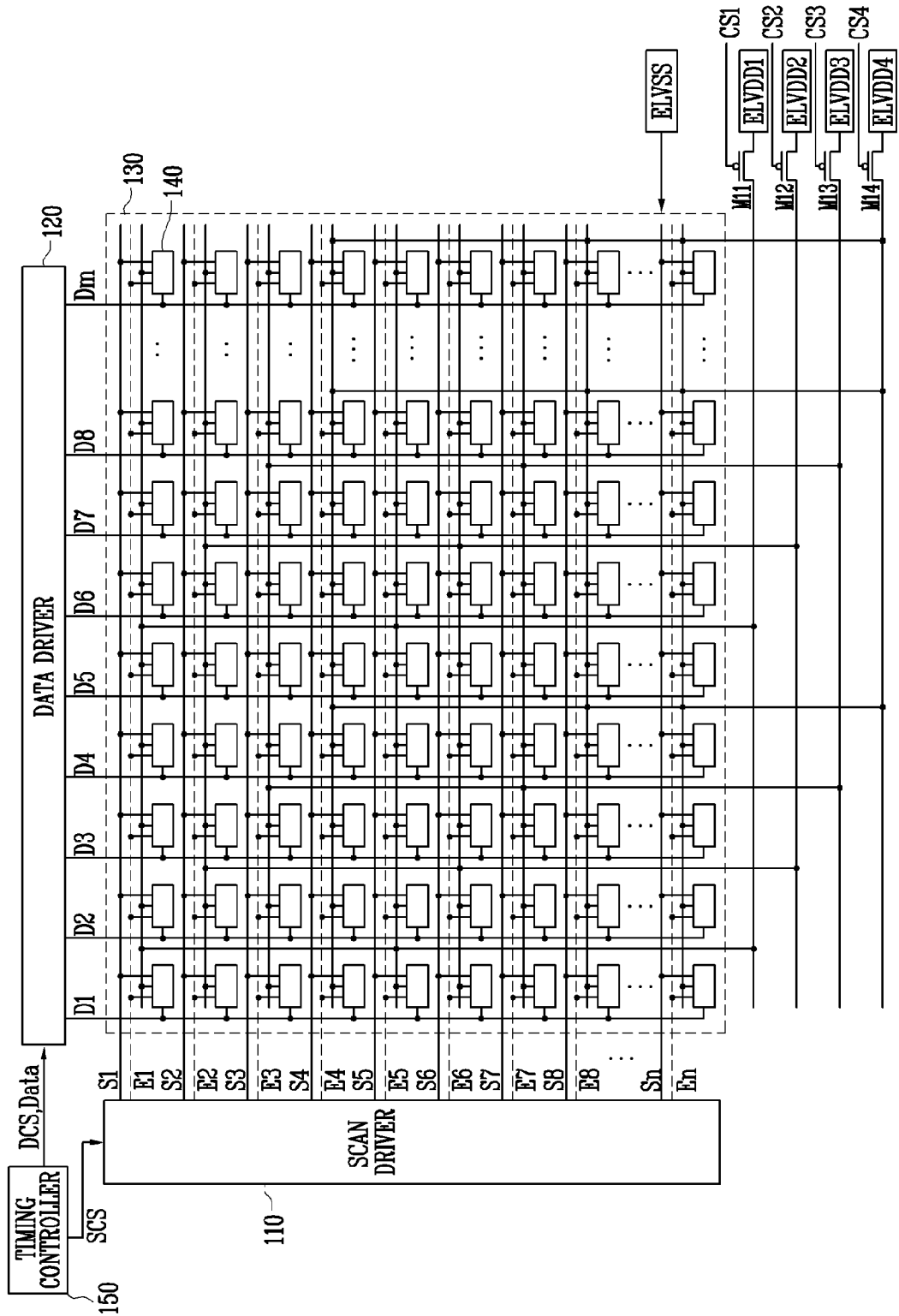

FIG. 8

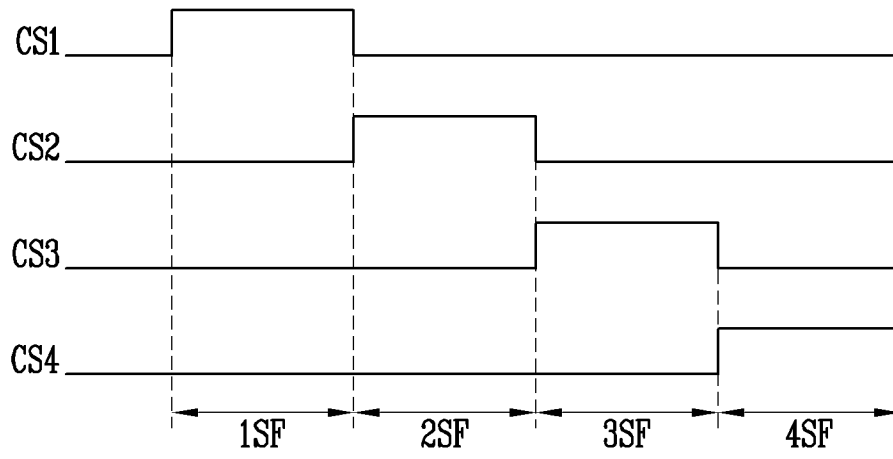

FIG. 9

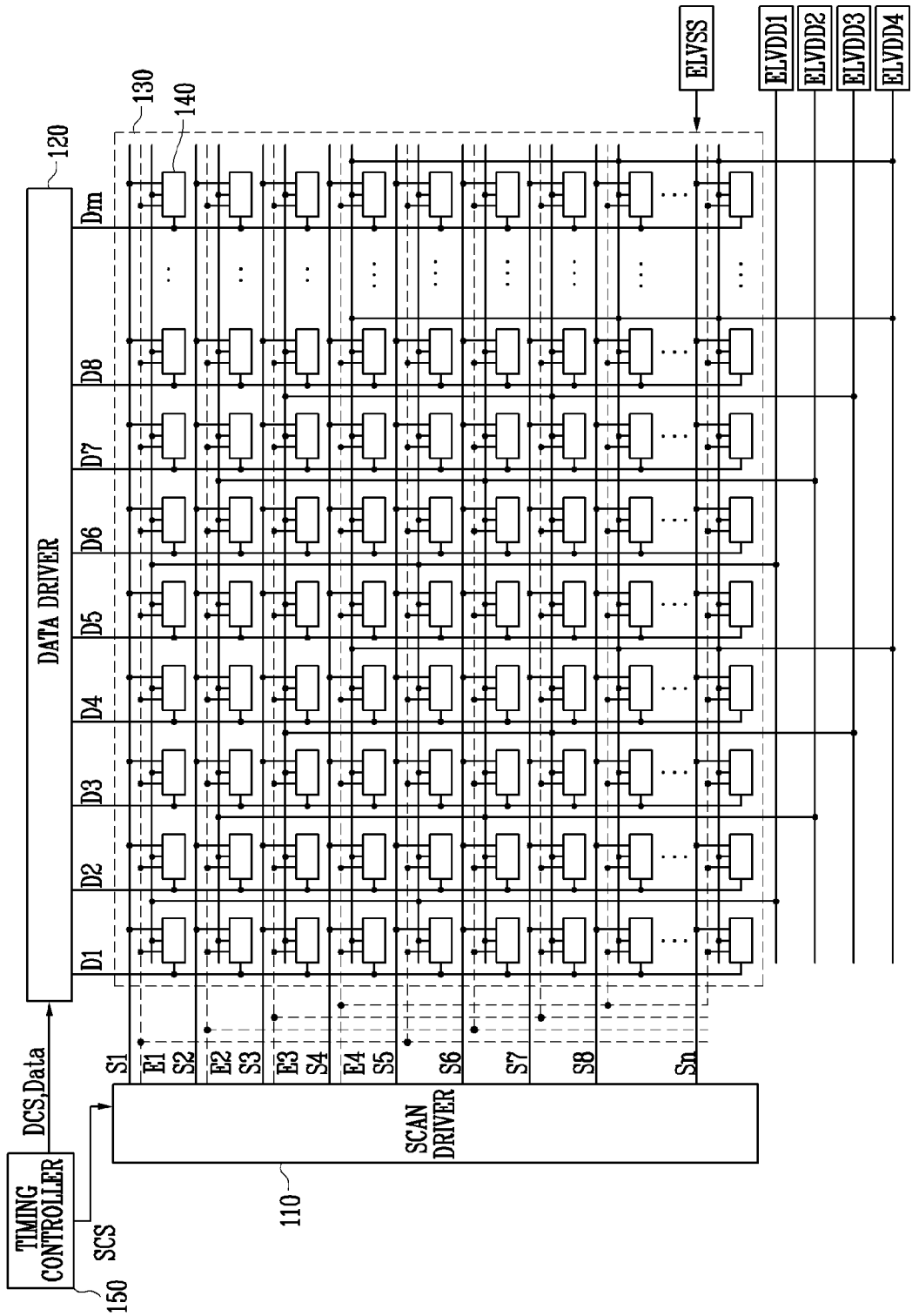

FIG. 10

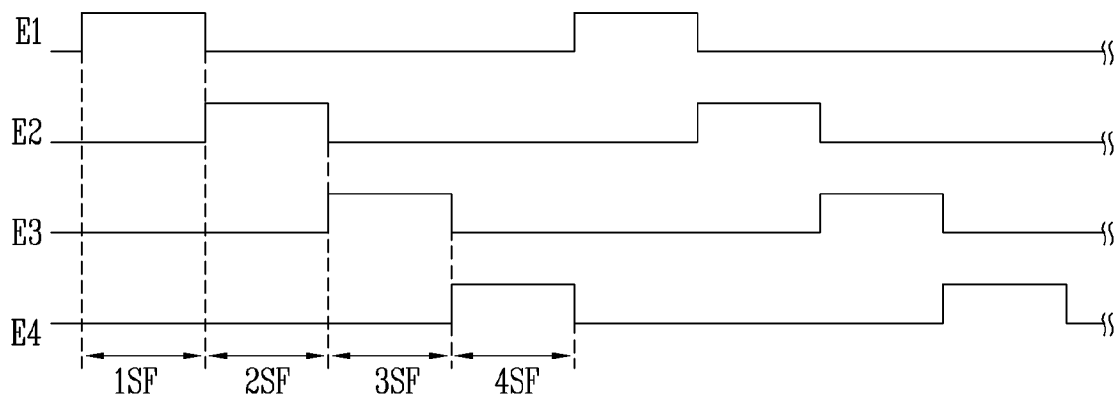

FIG. 11

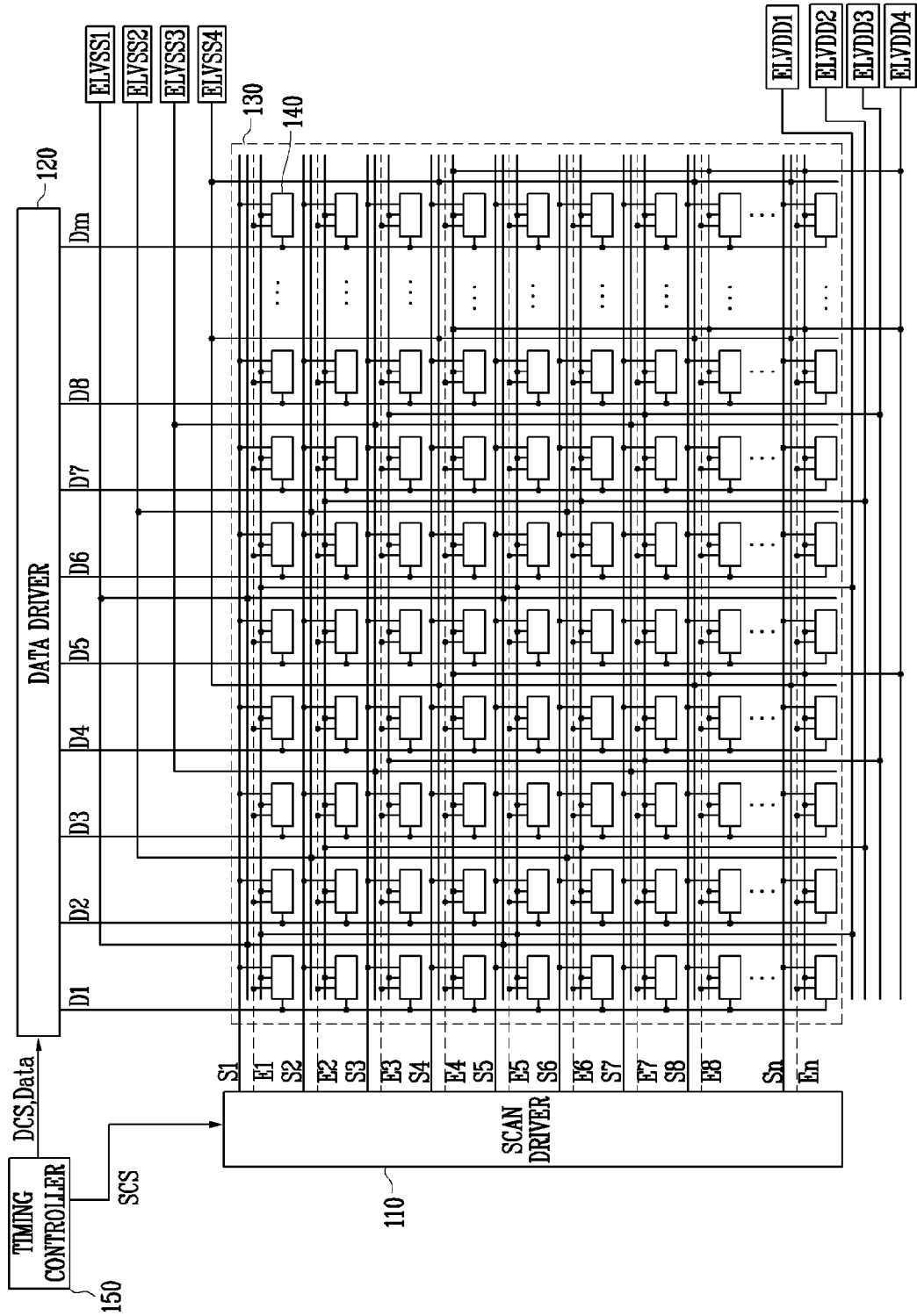

FIG. 12

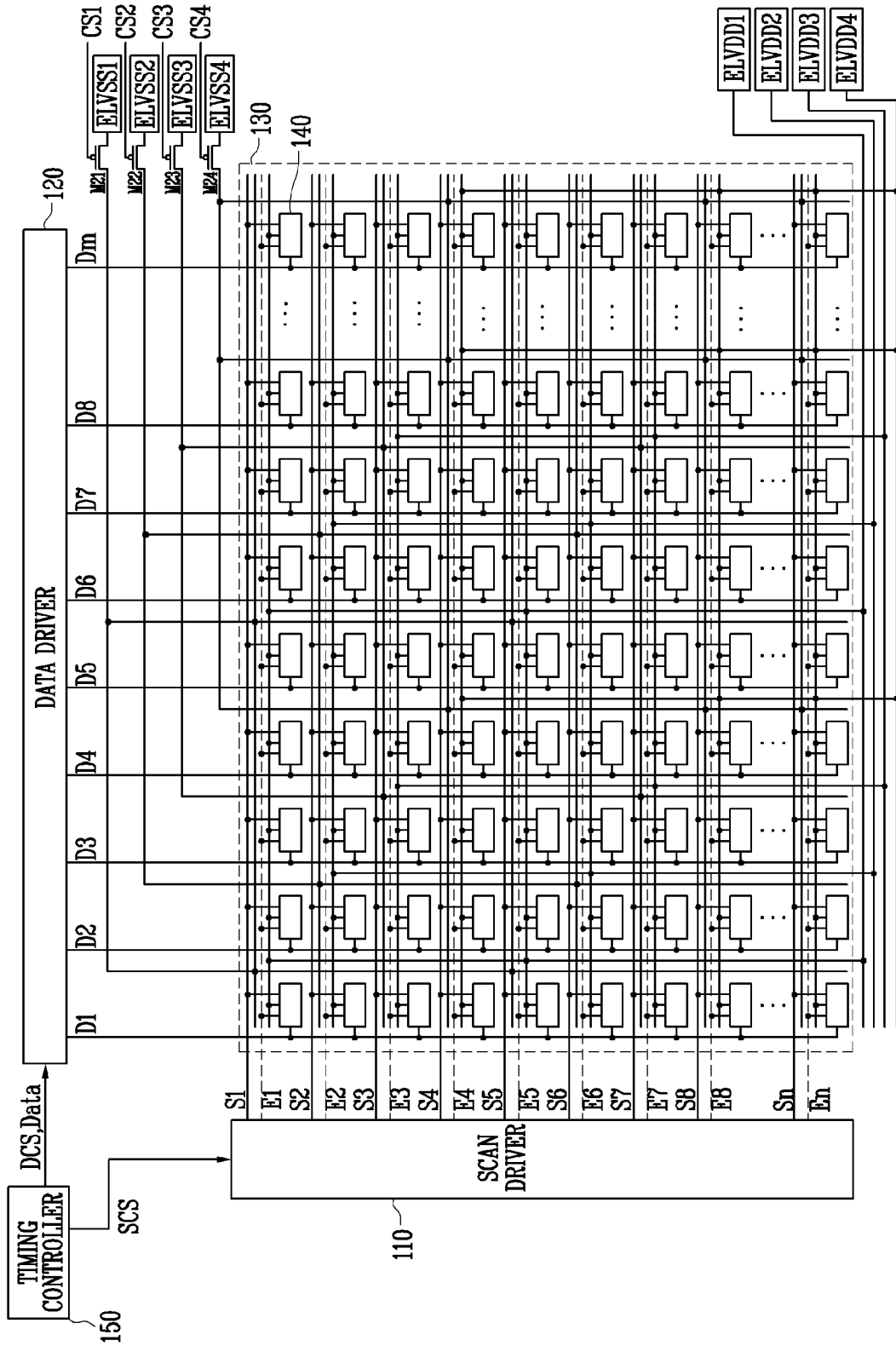

FIG. 13

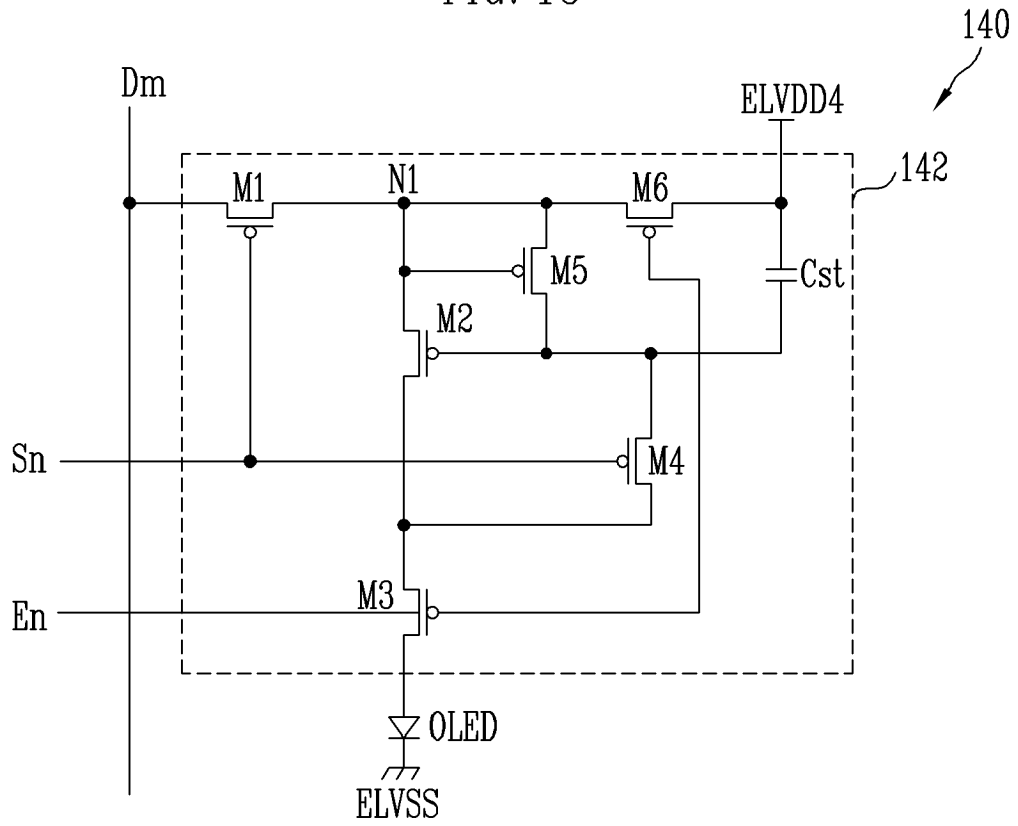
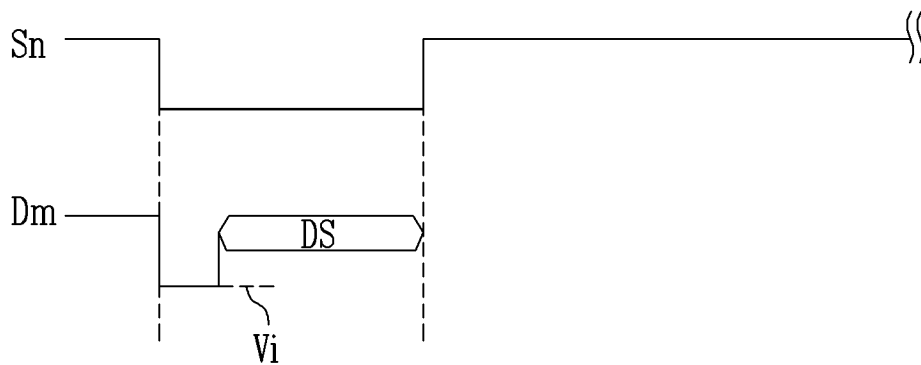

FIG. 14



专利名称(译)	有机发光二极管显示器及其驱动方法		
公开(公告)号	EP1675095A2	公开(公告)日	2006-06-28
申请号	EP2005112583	申请日	2005-12-21
[标]申请(专利权)人(译)	三星斯笛爱股份有限公司		
申请(专利权)人(译)	三星SDI CO. , LTD.		
当前申请(专利权)人(译)	三星移动显示器有限公司.		
[标]发明人	CHOI SANG MOO LEGAL & IP TEAM		
发明人	CHOI, SANG MOO LEGAL & IP TEAM		
IPC分类号	G09G3/32		
CPC分类号	G09G3/3233 G09G3/3266 G09G2300/043 G09G2300/0819 G09G2300/0842 G09G2300/0861 G09G2310/0251 G09G2320/0209 G09G2320/0223 G09G2320/043 G09G2330/02		
代理机构(译)	hengelhaupt , Jürgen		
优先权	1020040112517 2004-12-24 KR		
其他公开文献	EP1675095A3 EP1675095B1		
外部链接	Espacenet		

摘要(译)

有机发光二极管显示器及其驱动方法具有以均匀亮度显示的图像。驱动有机发光二极管显示器的方法包括将一帧分成一个或多个子帧，并且将扫描信号依次提供给每个子帧的像素部分中提供的多条扫描线中的一些扫描线。接收扫描信号的扫描线每个子帧被不同地设置。利用这种配置，以均匀的亮度显示图像。

FIG. 4

