



(11) **EP 1 628 285 B1**

(12) **EUROPEAN PATENT SPECIFICATION**

(45) Date of publication and mention of the grant of the patent:  
**31.03.2010 Bulletin 2010/13**

(51) Int Cl.:  
**G09G 3/32<sup>(2006.01)</sup>**

(21) Application number: **05107585.1**

(22) Date of filing: **18.08.2005**

(54) **Method for managing display data of a light emitting display**

Verwaltung von Anzeigedaten einer lichtemittierenden Anzeigevorrichtung

Gestion de données d'affichage d'un dispositif d'affichage électroluminescent

(84) Designated Contracting States:  
**DE FR GB**

(30) Priority: **20.08.2004 KR 2004065778**

(43) Date of publication of application:  
**22.02.2006 Bulletin 2006/08**

(73) Proprietor: **Samsung Mobile Display Co., Ltd.**  
**Suwon-si**  
**Gyeonggi-do (KR)**

(72) Inventors:  
• **LEE, Kyoung-Soo,**  
**Samsung SDI Co., Ltd.**  
**Yongin-City, Kyeonggi-Do (KR)**

• **Song, June-Young,**  
**Samsung SDI Co., Ltd.**  
**Yongin-City, Kyeonggi-Do (KR)**

(74) Representative: **Hengelhaupt, Jürgen**  
**Gulde Hengelhaupt Ziebig & Schneider**  
**Patentanwälte - Rechtsanwälte**  
**Wallstrasse 58/59**  
**10179 Berlin (DE)**

(56) References cited:  
**EP-A- 0 241 562**                    **EP-A- 0 637 009**  
**EP-A- 1 441 325**                    **EP-A- 1 536 406**  
**EP-A- 1 594 118**                    **WO-A2-03/077231**  
**US-A- 5 019 807**                    **US-A- 6 011 530**  
**US-A1- 2002 070 909**              **US-A1- 2005 168 490**  
**US-B1- 6 421 033**                    **US-B1- 6 707 441**

**EP 1 628 285 B1**

Note: Within nine months of the publication of the mention of the grant of the European patent in the European Patent Bulletin, any person may give notice to the European Patent Office of opposition to that patent, in accordance with the Implementing Regulations. Notice of opposition shall not be deemed to have been filed until the opposition fee has been paid. (Art. 99(1) European Patent Convention).

**Description****BACKGROUND OF THE INVENTION****Field of the Invention**

[0001] The present invention relates to a method for managing display memory data of a light emitting display, and more particularly, it relates to a method for managing display memory data of an organic light emitting display (referred to as an "OLED" hereinafter) using light emission of organic materials.

**Description of the Related Art**

[0002] Generally, an active matrix display such as a liquid crystal display and an OLED includes a plurality of scan lines arranged in the row direction and a plurality of data lines arranged in the column direction at the display area. Neighboring scan lines and data lines define each pixel area, and a plurality of pixels are formed in the pixel areas in a matrix format. Each pixel includes an active element, that is, a transistor to transmit a data signal provided through the data line in response to a selecting signal transmitted through a selecting scan line. Accordingly, the above-noted display needs a data driver for driving data lines and a scan driver for driving selecting scan lines.

[0003] Also, the above-noted display has further data lines coupled with red, green, and blue (R, G, B) pixels arranged continuously in a row direction in order that it may display various colors by combining the brightness of R pixels for emitting red light (hereinafter referred to as "R"), the brightness of G pixels for emitting green light (hereinafter referred to as "G"), and the brightness of B pixels for emitting blue light (hereinafter referred to as "B").

[0004] Each pixel includes a plurality of sub-pixels for various colors, and the various colors are displayed by combining lights of various colors emitted from such sub-pixels. Generally, each pixel includes a sub-pixel to display R, a sub-pixel to display G, and a sub-pixel to display B such that these R, G, and B sub-pixels are combined to display various colors.

[0005] Also, since the data driver converts digital signals into analog signals to apply the analog signals to the data lines, the data driver typically has output terminals of as many as the number of data lines. The data driver is generally manufactured with a plurality of ICs, which respectively has a limited number of the output terminals, and hence, many ICs are required to drive the data lines. Also, since many transistors, capacitors, and lines for transmitting voltages or signals are required for one pixel, it is difficult to arrange these elements in a single pixel. Further, since data lines are respectively formed corresponding to the R, G, and B pixels at the limited display area and the drivers for driving these pixels are respectively formed therein, there is a problem

in which the aperture ratio of pixels is reduced.

[0006] EP 1 441 325 discloses pixel circuits suitable for OLED display devices, an OLED display device employing such pixel circuits and a driving method for an OLED display device.

[0007] US-B1-6,421,033 shows a pixel circuit wherein more than one OLEDs are connected to a single driving circuit in order to reduce the number of data lines in a display device and to improve aperture ratio.

**SUMMARY OF THE INVENTION**

[0008] Accordingly, a first aspect of the invention provides a light emitting display device as set forth in claim 1. A second aspect of the invention provides a light emitting display device as set forth in claim 2. A third aspect of the invention provides a method for operating the light emitting device of the first or the second aspect of the invention. Preferred embodiments are subject of the dependent claims 3 and 5, respectively.

**BRIEF DESCRIPTION OF THE DRAWINGS**

[0009] The accompanying drawings, together with the specification, illustrate exemplary embodiments of the present invention, and, together with the description, serve to explain the principles of the present invention.

[0010] Fig. 1 is a schematic plain view of an organic light emitting display according to an exemplary embodiment of the present invention.

[0011] Figs. 2A to 2C respectively show pixels and sub-pixels of an organic light emitting display according to an exemplary embodiment of the present invention.

[0012] Fig. 3 shows driving of two sub-pixels according to an exemplary embodiment of the present invention.

[0013] Fig. 4 schematically shows a light-emitting driving mechanism of neighboring sub-pixels according to a first exemplary embodiment of the present invention.

[0014] Fig. 5 schematically shows pixels of an organic light emitting display according to the first exemplary embodiment of the present invention.

[0015] Fig. 6 shows a circuit of pixels of an organic light emitting display according to the first exemplary embodiment of the present invention.

[0016] Fig. 7 is an input data map of an organic light emitting display according to the first exemplary embodiment of the present invention.

[0017] Figs. 8A and Fig. 8B respectively show principles of managing an input data map of an odd field and an even field according to the first exemplary embodiment of the present invention.

[0018] Figs. 9A and 9B are respectively an input data map of an odd field and an even field according to the first exemplary embodiment of the present invention.

[0019] Fig. 10 schematically shows a light-emitting driving mechanism between sub-pixels of the same color according to a second exemplary embodiment of the present invention.

**[0020]** Fig. 11 schematically shows pixels of an organic light emitting display according to the second exemplary embodiment of the present invention.

**[0021]** Fig. 12 is a circuit view of pixels of an organic light emitting display according to the second exemplary embodiment of the present invention.

**[0022]** Fig. 13 is a driving timing diagram of an organic light emitting display according to the second exemplary embodiment of the present invention.

**[0023]** Figs. 14A and 14B are respectively an input data map of an odd field and an even field according to the second exemplary embodiment of the present invention.

### DETAILED DESCRIPTION

**[0024]** In the following detailed description, only certain exemplary embodiments of the invention are shown and described, simply by way of illustration. As those skilled in the art would realize, the described embodiments may be modified in various different ways. Accordingly, the drawings and description are to be regarded as illustrative in nature, and not restrictive. There may be parts shown in the drawings, or parts not shown in the drawings, that are not discussed in the specification as they are not essential to a complete understanding of the invention. Like reference numerals designate like elements.

**[0025]** Hereinafter, a managing method for managing display memory data of a light emission display according to an exemplary embodiment of the present invention will be described in detail with reference to the accompanying drawings.

**[0026]** Fig. 1 is a schematic plain view of an organic light emitting display.

**[0027]** With reference to Fig. 1, an organic light emitting display according to an exemplary embodiment of the present invention includes a display panel 100, a selecting scan driver 200, a light-emitting scan driver 300, a data driver 400, and a memory 500. Input data for display images are stored in the memory 500.

**[0028]** The display panel 100 includes a plurality of scan lines S1 to Sn and E1 to En, arranged in a row direction, a plurality of data lines D1 to Dm arranged in a column direction, a plurality of power lines VDD, and a plurality of pixels 110. Each of the pixels 110 is formed at a pixel area defined by two neighboring scan lines S1 to Sn and two neighboring data lines D1 to Dm.

**[0029]** The selecting scan driver 200 sequentially applies selecting signals to the scan lines S1 to Sn so as to write data signals on the pixels coupled to the corresponding scan lines, and the light emitting scan driver 300 sequentially applies light emitting signals to the light emitting scan lines E1 to En so as to control the light emitting of an organic light emitting display. Since the light emitting signals control light emission in the organic light emitting display, they may also be referred to as "emission control signals." Similarly, the light emitting scan driver 300 may also be referred to as an emission

control driver. The data driver 400 applies data signals to the data lines D1 to Dm, whenever the selecting signal is sequentially applied to the scan lines S1 to Sn.

**[0030]** The selecting scan driver 200, the light-emitting scan driver 300 and the data driver 400 are respectively coupled with the substrate having the display panel 100 formed thereon. However, the scan drivers 200 and 300 and/or the data driver 400 may be mounted directly on the grass substrate of the display panel 100, and they may be replaced with the driving circuit formed on the same layer as those of the scan line, the data lines, and the transistor on the substrate of the display panel 100. Also, the scan drivers 200, 300 and/or the data driver 400 may be mounted in the form of a chip at a tape carrier package (TCP), a flexible printed circuit (TCP), or a tape automatic bonding (TAB), which is coupled to the substrate of the display panel 100.

**[0031]** Figs. 2A to 2C respectively show pixels and sub-pixels of an organic light emitting display according to an exemplary embodiment of the present invention. Figs. 2A to 2C illustrate the pixel light emitting sequence of odd/even fields of a 2:1 multiplexer in the organic light emitting display according to an exemplary embodiment of the present invention.

**[0032]** Fig. 2A shows pixels of the organic light emitting display, where R, G, and B pixels are arranged in the column direction starting from the first line in the row direction. When the slashed pixels are removed from Fig. 2A, the sub-pixels of odd fields remain as shown in Fig. 2B, and when the slashed pixels are arranged, the sub-pixels of even fields are arranged as shown in Fig. 2C.

**[0033]** Fig. 3 shows driving of two sub-pixels according to an exemplary embodiment of the present invention, where a driving IC uses one output to drive the two sub-pixels as shown in Figs. 2B and 2C. Here, when it is given that  $k=0, 1, 2, 3, \dots, n-1$ , the outputs of the driving IC are generated to be S1, S2, S3, S4, S5, S6, ..., S(3k+1), S(3k+2), and S(3k+3). The pixels are respectively classified into odd pixels and even pixels and include R, G, and B so that the number of pixels is 6n (n is a positive integer) per line.

**[0034]** Fig. 4 schematically shows a light-emitting driving mechanism of adjacent sub-pixels according to a first exemplary embodiment of the present invention.

**[0035]** With reference to Fig. 4, in the organic light emitting display according to the first exemplary embodiment of the present invention, the light-emitting driving between adjacent sub-pixels is achieved in response to writing the data of different colors at two subfields, is executed by the odd and even fields, and each achieves the light-emitting of one of R, G, and B organic light emitting element indicated by the dotted lines at an odd line (as shown on the upper part of the drawing) and at an even line (as shown on the lower part thereof). Here, each selected signal is coupled to two adjacent organic light emitting elements, and the organic light emitting elements indicated by the dotted lines emit light starting from the first line to the final line in the column direction at the

odd and even fields to make a one-frame image, generally outputting 60 frames per second.

**[0036]** Fig. 5 schematically shows pixels of an organic light emitting display according to the first exemplary embodiment of the present invention.

**[0037]** With reference to Fig. 5, each pixel 110a, 110b or 110c includes two light emitting elements for emitting light of different colors, and a driver for driving the organic light emitting elements. These organic light emitting elements emit the light of a brightness corresponding to an applied current. Hereinafter, one pixel will be defined by a driver and two organic light emitting elements formed at the pixel area,

**[0038]** According to the first exemplary embodiment of the present invention, one field is divided into two sub-fields to be driven, and the data of different colors are written on the two sub-fields to thus emit light.

**[0039]** For this end, the selecting scan driver 200 (shown in Fig. 1) sequentially applies the selecting signals to the selecting scan lines S1 to Sn for each sub-field, and the light-emitting scan driver 300 applies the light emitting signal to the light-emitting scan lines E1 to En so that the organic light emitting element of each color may emit light at a single sub-field.

**[0040]** The data driver 400 applies the data signals to the data lines D1 to Dm, the data signals corresponding to the organic light emitting elements of different colors in two subfields. In Fig. 5, the data driver 400 applies data signals corresponding to the red and green organic light emitting elements OLEDr1 and OLEDg1 to the data line D1 in two sub-fields, applies data signals corresponding to the blue and red organic light emitting elements OLEDb1 and OLEDr2 to the data line D2, and applies data signals corresponding to the green and blue organic light emitting elements OLEDg2 and OLEDb2 to the data line D3.

**[0041]** With reference to Fig 6, a detailed operation of an organic light emitting display according to the first exemplary embodiment of the present invention will be described.

**[0042]** Fig. 6 shows a circuit of a pixel of an organic light emitting display according to the first exemplary embodiment of the present invention. In Fig. 6, the pixels coupled to the data lines D1 to D3 and the selecting scan line Sn are illustrated, and transistors are illustrated to be p channel transistors.

**[0043]** Hereinafter, the selecting scan line which will currently transmit a selecting signal will be referred to as "the current scan line," and the selecting scan line which had transmitted a selecting signal before the current selecting signal is transmitted will be referred to as "the previous scan line."

**[0044]** The pixel 110a according to the first exemplary embodiment of the present invention includes a driving transistor M11, switching transistors M12 to M14, capacitors C11 and C12, organic light emitting elements OLEDr1 and OLEDg1, and light-emitting transistors M15a and M15b for controlling light emission of the or-

ganic light emitting elements OLEDr1 and OLEDg1. The pixel 110b includes a driving transistor M21, switching transistors M22 to M24, capacitors C21 and C22, organic light emitting elements OLEDb1 and OLEDr2, and light-emitting transistors M25a and M25b for controlling light emission of the organic light emitting elements OLEDb1 and OLEDr2. The pixel 110c includes a driving transistor M31, switching transistors M32 to M34, capacitors C31 and C32, organic light emitting elements OLEDg2 and OLEDb2, and light-emitting transistors M35a and M35b for controlling light emission of the organic light emitting elements OLEDg2 and OLEDb2. Since the operations of the three pixels 110a to 110c are substantially the same as one another, the operation of one pixel will be described based on the operation of the pixel 110a.

**[0045]** One light-emitting scan line En includes two light-emitting signal lines Ena and Enb, while the other light-emitting scan line includes two light-emitting signal lines (not shown in Fig. 6). The above-noted light-emitting transistors M15a and M15b and light-emitting signal lines Ena and Enb configure a switch for selectively transmitting the current provided by the driving transistor M11 to the organic light emitting elements OLEDr1 and OLEDg1.

**[0046]** The transistor M11 is a driving transistor for driving the OLED and is coupled between a power source of voltage VDD and a node of sources of the transistors M15a and M15b. The transistor M11 controls the current applied to the organic light emitting elements OLEDr1 and OLEDg1 through the transistor M15a and M15b, respectively, according to a voltage applied across the gate and source of the transistor M11. Also, the transistor M12 diode-connects the driving transistor M11 in response to the selecting signal transmitted from the previous scan line Sn-1.

**[0047]** One electrode A of the capacitor C12 is coupled to the gate of the driving transistor M11, and the capacitor C11 and transistor M13 are coupled in parallel between the other electrode B of the capacitor C12 and the power source of the voltage VDD. The transistor M13 supplies the voltage of VDD to the other electrode B of the capacitor C12 in response to the selecting signal provided from the previous scan line Sn-1.

**[0048]** Also, the switching transistor M14 transmits the data voltage supplied from the data lines Dm to the capacitor C11 in response to the selecting signal provided from the current scan line Sn. Also, the light-emitting transistors M15a and M15b are respectively coupled between the drain of the transistor M11 and anodes of the organic light emitting elements OLEDr1 and OLEDg1, and transmit the current from the transistor M11 to the organic light emitting elements OLEDr1 and OLEDg1 in response to the light-emitting signal applied from the light-emitting signal lines Ena and Enb.

**[0049]** The organic light emitting elements OLEDr1 and OLEDg1 respectively emit red and green lights corresponding to the applied current. In accordance with the first exemplary embodiment of the present invention, a power supply voltage of VSS, which is lower than the

voltage of VDD, is applied to cathodes of the organic light emitting elements OLEDr1 and OLEdg1. The power supply voltage of VSS may be a negative voltage or the ground voltage, by way of example.

**[0050]** The operation of the pixel 110a will be described in detail.

**[0051]** When the low-level selecting signal is applied to the previous scan line Sn-1, the transistor M12 is turned on to diode-connect the driving transistor M11. Therefore, the voltage across the gate and source of the driving transistor M11 is varied until it reaches the threshold voltage VTH of the transistor M11. Since the voltage of VDD is applied to the source of the transistor M11, the voltage applied to the gate of the transistor M11, that is, the electrode A of the capacitor C12 becomes the voltage of (VDD+VTH). Also, the transistor M13 is turned on to apply the voltage of VDD to the other electrode B of the capacitor C12.

**[0052]** Since the high-level light-emitting signal is applied to the light-emitting signal lines Ena and Enb, the transistors M15a and M15b are turned off, and no current flows through the transistor M11 to the organic light emitting elements OLEDr and OLEdg.

**[0053]** The transistor M14 is intercepted since the high-level signal is applied to the current scan line Sn.

**[0054]** When the low-level selecting signal is applied to the current scan line Sn, the transistor M14 is turned on so that the data voltage VDATA is charged in the capacitor C11. Also, since the voltage corresponding to the threshold voltage VTH at the transistor M11 is charged in the capacitor C12, the sum of the data voltage VDATA and threshold voltage VTH of the transistor M11 is applied to the gate of the transistor M11.

**[0055]** When the light-emitting transistors M15a and M15b are respectively turned on in response to the light-emitting signals transmitted from the light-emitting signal lines Ena and Enb, the current is transmitted to the red and green organic light emitting elements OLEDr1, OLEdg1 to thus emit light.

**[0056]** The selecting signal is sequentially applied to the selecting scan line S1 to Sn at two sub fields included in a field, and the two light-emitting signals respectively applied to two light-emitting signal lines E1a to Ena and E1b to Enb have a low-level period which is not repeated during one field.

**[0057]** Also, the pixels 110b and 110c store the threshold voltages of the driving transistor M21 and M31 in the capacitors C22 and C32 while the selecting signal is applied to the previous scan line Sn-1 in a like manner as the pixel 110a, and store the data voltage VDATA in the capacitors C21 and C31 while the selecting signal is applied to the current scan line Sn. When the light-emitting transistors M25a and M35a are turned on in response to the light-emitting signal applied from the light-emitting signal line Ena, the currents respectively corresponding to the voltages stored in the capacitors C21 and C31 are transmitted to the blue and green organic light emitting elements OLEDb1 and OLEdg2 to thus emit light, and

when the light-emitting transistors M25b and M35b are turned on in response to the light-emitting signal applied from the light-emitting signal line Enb, the currents corresponding to the voltages charged in the capacitors C21 and C31 are transmitted to the red and blue organic light emitting elements OLEDr2 and OLEDb2 to thus emit light.

**[0058]** Fig. 7 is an input data map of an organic light emitting display according to the first exemplary embodiment of the present invention.

**[0059]** With reference to Fig. 7, the data inputted from the data driver 400 of the organic light emitting display are arranged such that 6n-numbered R, G, and B pixels are arranged per line.

**[0060]** Figs. 8A and Fig. 8B respectively illustrate the principle to manage an input data map of odd and even fields according to the first exemplary embodiment of the present invention, illustrating that the input data map shown in Fig. 7 is divided into the memory map of the odd field and the memory map of the even field. That is to say, the input data map is separated into the odd field data as shown in Fig. 8A and the even field data as shown in Fig. 8B, respectively illustrating up to sixth R, G, and B pixels of 4 lines. The lower data surrounded by the thick line in Figs. 8A and 8B are classified to include R, G, and B data. When 6n input data are supplied in columns, the memory map is provided with the first and second sub-field each of which has 3n data in columns.

**[0061]** Figs. 9A and Fig. 9B are respectively an input data map of the odd and even fields according to the first exemplary embodiment of the present invention, and when k=0, 1, 2, ..., n-1 in the lower part of data of Figs. 8A and 8B, three kinds of data are classified by the selecting signals S(3k+1), S(3k+2), and S(3k+3).

**[0062]** With reference to Fig. 9A, in the memory map of the odd field according to the first exemplary embodiment of the present invention, for example, since k=0 on the first line, when S(3k+1) is S1, the light-emitting data are stored in the range of from R(1, 1) to R(1, 6n-1), when S(3k+2) is S2, the light-emitting data are stored in the range of from B(1, 1) to B(1, 6n), and when S(3k+3) is S3, the light-emitting data are stored in the range of from G(1, 1) to G(1, 6n-1). Also, since k=0 on the second line, when S(3k+1) is S1, the light-emitting data are stored in the range of from G(2, 1) to G(2, 6n-1), when S(3k+2) is S2, the light-emitting data are stored in the range of from R(2, 2) to R(2, 6n), and when S(3k+3) is S3, the light-emitting data are stored in the range of from B(2, 2) to B(2, 6n). Next lines are stored in the odd-field memory map in a like manner as the above-stated description for the odd lines and even lines.

**[0063]** Also, with reference to Fig. 9B, in the memory map of the even field according to the first exemplary embodiment of the present invention, for example, since k=0 on the first line, when S(3k+1) is S1, the light-emitting data are stored in the range of from G(1, 1) to G(1, 6n-1), when S(3k+2) is S2, the light-emitting data are stored in the range of from R(1, 1) to R(1, 6n), and when S(3k+3)

is S3, the light-emitting data are stored in the range of from B(1, 1) to B(1, 6n). Also, since k=0 on the second line, when S(3k+1) is S1, the light-emitting data are stored in the range of from R(2, 1) to R(2, 6n-1), when S(3k+2) is S2, the light-emitting data are stored in the range of from B(2, 1) to B(2, 6n-1), and when S(3k+3) is S3, the light-emitting data are stored in the range of from G(2, 2) to G(2, 6n). Next lines are stored in the even-field memory map in a like manner as the above-stated description for odd lines and even lines.

**[0064]** Accordingly, as shown in Figs. 9A and 9B, the light-emitting data for adjacent sub-fields for each line are classified and stored for each sub-field.

**[0065]** Also, since the light-emitting element of various colors can be driven by common driving and switching transistors and a capacitor at one pixel, the constitution of the elements used in the pixel, and wiring of lines for transmitting the currents, voltages, or signals can be simplified.

**[0066]** However, in the case of driving the pixel according to the first exemplary embodiment of the present invention, the voltages stored in the capacitors C12 to C32 are varied according to the drain electrode of the driving transistors M11 to M31, that is, the voltage at the node C. That is to say, when the current flows through the driving transistors M11 to M31, a predetermined voltage is charged due to the drain electrode, that is, the parasitic capacitance of the node C so that the voltage at the node C depends on the level of the current input to the driving transistors M11 to M31 in the previous sub-field. Accordingly, when the low-level selecting signal is applied to the previous scan line Sn-1, one electrode A of the capacitor C12 has the same voltage VC12 as the voltage of the node C so that the voltage stored in the capacitor C12 is varied according to the voltage at the node C.

**[0067]** The pixels 110a to 110c according to the first exemplary embodiment of the present invention receive the current corresponding to the different colors in two subfields, so that the compensated voltage, which is stored in the capacitors C12 to C32 while the selecting signal is applied to the previous scan line Sn-1 in a single subfield, depends on the current supplied by the driving transistors M11 to M31 in the previous subfield.

**[0068]** As a result, there is a problem in that the driving transistors M11 to M31 have the threshold voltages of which the deviations are insufficiently compensated because the compensated voltage is charged in the capacitors C12 to C32 according to the data voltage of the previous subfield and the data voltages corresponding to the different colors are applied in the previous subfield and the current subfield.

**[0069]** Also, there is a problem in that it is difficult to control the white balance of the red, green, and blue images by controlling the characteristics of the driving transistor because the pixel according to the first exemplary embodiment of the present invention has a driving transistor for driving the organic light emitting elements of different colors.

**[0070]** Consequently, as described hereafter, an organic light emitting display according to a second exemplary embodiment of the present invention solves the above-noted problem by controlling the driver provided at a pixel to drive organic light emitting elements of the same color.

**[0071]** The pixel of the organic light emitting display according to a second exemplary embodiment of the present invention will be described in detail with reference to Figs. 10 to 14.

**[0072]** Fig. 10 schematically shows light-emitting driving occurring between sub-pixels of the same color according to the second exemplary embodiment of the present invention.

**[0073]** With reference to Fig. 10, in the organic light emitting display according to the second exemplary embodiment of the present invention, the light-emitting driving between adjacent sub-pixels is achieved in response to the writing of the data of the same color at two subfields, divided into odd and even fields, and each achieves the light-emitting of one of R, G, and B organic light emitting elements indicated by the dotted-line at an odd line (as shown at the upper part of Fig. 10) and an even line (as shown at the lower part of Fig. 10). Here, each selecting signal is coupled with two organic light emitting elements having the same color, the light-emitting of the organic light emitting elements indicated by the dotted lines at the odd and even fields is achieved according to a column direction, and is achieved up to the last line to make one frame image, generally to output 60 frames per second.

**[0074]** Each light-emitting driving between the sub-pixels is divided. Fig. 11 schematically shows the pixel of the organic light emitting display according to the second exemplary embodiment of the present invention. In Fig. 11, three pixels 110a'-110c' coupled to data lines D1-D3 and a selecting scan line Sn are illustrated representatively.

**[0075]** In accordance with the second exemplary embodiment of the present invention, each of the pixels 110a'-110c' includes one of drivers 111', 112' and 113', two organic light emitting elements to emit light of different colors, and the data lines D1-D3 having the data signals corresponding to the red, green, and blue lights supplied thereto.

**[0076]** The driver 111' of the pixel 110a' is coupled to the data line D1 so that it applies the current corresponding to the data voltage transmitted from the data line D1 to the red organic light emitting elements OLEDr1 or OLEDr2. The driver 112' of the pixel 110b' is coupled to the data line D2 so that it applies the current corresponding to the data voltage transmitted from the data line D2 to the green organic light emitting elements OLEDg1 or OLEDg2. Further, the driver 113' of the pixel 110c' is coupled to the data line D3 so that it applies the current corresponding to the data voltage transmitted from the data line D3 to the blue organic light emitting elements OLEDb1 or OLEDb2.

**[0077]** Hereinafter, detailed operation of an organic

light emitting display according to the second exemplary embodiment of the present invention is described with reference to Fig. 12. However, descriptions that are redundant to those of the first exemplary embodiment will be omitted.

**[0078]** Fig. 12 is a circuit of pixel of an organic light emitting display according to the second exemplary embodiment of the present invention.

**[0079]** With reference to Fig. 12, the driver of the pixel 110a' includes a driving transistor M11, switching transistors M12-M14, capacitors C11 and C12, and light-emitting transistors M15a and M15b. The driver of the pixel 110b' includes a driving transistor M21, switching transistors M22 to M24, capacitors C21 and C22, and light-emitting transistors M25a and M25b, the driver of the pixel 110c' includes a driving transistor M31, switching transistors M32 to M34, capacitors C31 and C32, and light-emitting transistors M35a and M35b.

**[0080]** According to the second exemplary embodiment, a drain of the driving transistor M11 is coupled to sources of the light-emitting transistors M15a and M25b, and the light-emitting transistors M15a and M25b transmit the current transmitted from the driving transistor M11 to the organic light emitting elements OLEDr1 and OLEDr2 in response to the light-emitting signals transmitted from the light-emitting signal lines Ena and Enb.

**[0081]** A drain of the driving transistor M21 is coupled with sources of the light-emitting transistors M35a and M15b so that the light-emitting transistors M35a and M15b transmit the current transmitted from the driving transistor M21 to the organic light emitting elements OLEDg1 and OLEDg2 in response to the light-emitting signals transmitted from the light-emitting signal lines Ena and Enb.

**[0082]** A drain of the driving transistor M31 is coupled to sources of the light-emitting transistors M25a and M35b, and the light-emitting transistors M25a and M35b transmit the current transmitted from the driving transistor M31 to organic light emitting elements OLEDb1 and OLEDb2 in response to the light-emitting signals transmitted from the light-emitting signal lines Ena and Enb.

**[0083]** As a result, the data voltage corresponding to the same color is applied to one data line during one field (i.e., two subfields), and the driving transistor transmits the current corresponding to the data voltage to the organic Light emitting elements of the same color.

**[0084]** Hereinafter, the driving method of the organic light emitting display will be described in detail with reference to Fig.13.

**[0085]** Fig. 13 is a driving timing view of the organic light emitting display according to the second exemplary embodiment of the present invention.

**[0086]** In the organic light emitting display according to the second exemplary embodiment, one field 1 TV is divided into two subfields 1SF and 2SF to be driven, and the selection signal having a low level is sequentially applied to the scan lines S1-Sn during each of the subfields 1SF and 2SF. Each of two organic light emitting elements

included in one pixel emits light during a corresponding one of the two subfields. The subfields 1 SF and 2SF are defined independently for columns, and Fig. 13 shows two subfields 1 SF and 2SF based on the selecting scan line S1 of the first column.

**[0087]** While the low-level selection signal is applied to the previous scan line Sn-1 during the subfield 1SF, the voltage corresponding to threshold voltage VTH of the driving transistors M11, M21 and M31 is stored in the capacitors C12, C22 and C32, respectively. Thereafter, when the low-level selection signal is applied to the current scan line Sn, the data voltages corresponding to the red, green, and blue colors are respectively applied to the data lines D1 to D3, and the data voltages are charged in the capacitors C11, C21 and C31 through the transistors M14, M24 and M34, respectively. Also, when the light-emitting transistors M15a, M35a and M25a are turned on, currents corresponding to the voltages stored in the capacitors C11, C21 and C31 are transmitted through the transistors M11, M21 and M31 to the organic light emitting elements OLEDr1, OLEDg2, and OLEDb1, respectively, to achieve the light emission.

**[0088]** In a like manner, data voltages are applied to the pixels of the first through nth columns during the subfield 1SF so that the left one of two organic light emitting elements emits light in each pixel.

**[0089]** During the next subfield 2SF, the low level selection signal is sequentially applied to the selecting scan lines S1 to Sn of first through nth columns in a like manner as in the subfield 1SF. The pixels 110a' to 110c' coupled to the current scan line Sn allow the voltage corresponding to the threshold voltage VTH of the driving transistors M11, M21 and M31 to be stored in the capacitors C12, C22 and C32, respectively, while the low level selected signal is applied to the previous scan line Sn-1 and the data voltages corresponding to the red, green and blue colors are stored in the capacitor C11, C21 and C31, respectively, while the selected signal is applied to the current scan line Sn. The low-level light-emitting signal is sequentially applied to the light-emitting signal lines E1b-Enb synchronized with the low level selection signals that are sequentially applied to the selecting scan lines S1-Sn. As a result, currents corresponding to the applied data voltages are transmitted to the organic light emitting elements OLEDr2, OLEDg1, and OLEDb2 through the light-emitting transistors M25b, M15b, and M35b, respectively, to emit light.

**[0090]** In accordance with the second exemplary embodiment, the light-emitting signals applied to the light-emitting signal lines E1a to Ena and E1b to Enb during the subfields 1SF and 2SF remain low level during a predetermined period, and the organic light emitting elements emit light continuously while the corresponding light-emitting signal is applied to the light-emitting transistor and the light-emitting signal remain low level. Fig. 13 shows a period that is substantially the same as this period.

**[0091]** That is to say, the organic light emitting ele-

ments coupled to the left part of each pixel emit light of a brightness in response to the data voltage applied during the period corresponding to the subfield 1SF, and the organic light emitting elements coupled to the right part of each pixel emit light of a brightness in response to the data voltage applied during the period corresponding to the subfield 2SF.

**[0092]** A data voltage corresponding to the same color is applied to each of the data lines D1-Dm during one field 1TV, and the driving transistor including one pixel transmits the current corresponding to the data voltage to the organic light emitting elements of the same color. Since the current corresponding to the same color is transmitted to the organic light emitting elements through the driving transistor during the two subfields, a voltage corresponding to the color that is the same as that of the present subfield is charged in the drain electrode of the driving transistor, the node C.

**[0093]** That is to say, in the case where a selection signal is applied to the previous scan line Sn-1 at the pixel 110a' to store the voltage corresponding to the threshold voltage of the transistor M11 in the capacitor C12, the voltage stored in the capacitor C12 depends on the voltage of the node C, and the voltage of the node C depends on the current flowed through the transistor M11 during the previous subfield as discussed above. In the second exemplary embodiment, since the driving transistor M11 outputs the current corresponding to the red color during both the previous subfield and the present subfield, the voltage for compensating the deviation of the threshold voltage of the transistor M11 under the same condition as that of the present subfield is stored in the capacitor C12.

**[0094]** As a result, although the drain electrode of the driving transistor M11 has a parasitic capacitance component so that a voltage different from the threshold voltage of the driving transistor M11 is stored at the capacitor C12, the voltage corresponding to the threshold voltage is stored at the capacitor C12 under the same condition as that of the present subfield and the previous subfield thereby effectively compensates the deviation of the threshold voltage of the driving transistor M11.

**[0095]** Since the driving transistor included in one pixel controls the current to flow into the organic light emitting elements of the same color, the driving transistor has the controlled ratio W/L of width to length of channel so that the white balance is regulated. That is, the driving transistor has the ratio W/L of width to length of channel set differently from each other so that the data voltage of the essentially same level allows a different amount of current to flow to a different one of the red, green, and blue organic light emitting elements.

**[0096]** Fig. 14A and Fig. 14B are respectively a memory map of an odd field and an even field according to the second exemplary embodiment of the present invention. In a like manner as the first exemplary embodiment, when  $k=0, 1, 2, \dots, n-1$ , the data of the lower part is classified into three kinds of data according to scan line se-

lecting signals  $S(3k+1)$ ,  $S(3k+2)$ , and  $S(3k+3)$ .

**[0097]** With reference to Fig. 14A, in the memory map of the odd field according to the second exemplary embodiment of the present invention, for example, since  $k=0$  at a first line, when  $S(3k+1)$  is S1, the light-emitting data are stored in the range of from R(1, 1) to R(1, 6n-1), when  $S(3k+2)$  is S2, the light-emitting data are stored in the range of from G(1, 2) to G(1, 6n), and when  $S(3k+3)$  is S3, the light-emitting data are stored in the range of from B(1, 1) to B(1, 6n-1). Also, since  $k=0$  at a second line, when  $S(3k+1)$  is S1, the light-emitting data are stored in the range of from R(2, 2) to R(2, 6n), when  $S(3k+2)$  is S2, the light-emitting data is stored in the range of from G(2, 1) to G(2, 6n-1), and when  $S(3k+3)$  is S3, the light-emitting data are stored in the range of from B(2, 2) to B(2, 6n). Thereafter, next lines are stored in the same manner as above-stated description for odd lines and even lines.

**[0098]** Similarly, with reference to Fig. 14B, in the memory map of the even field according to the second exemplary embodiment of the present invention, for example, since  $k=0$  at the first line, when  $S(3k+1)$  is S1, the light-emitting data are stored in the range of from R(1, 2) to R(1, 6n), when  $S(3k+2)$  is S2, the light-emitting data are stored in the range of from G(1, 1) to G(1, 6n-1), and when  $S(3k+3)$  is S3, the light-emitting data are stored in the range of from B(1, 2) to B(1, 6n). Also, since  $k=0$  at the second line, when  $S(3k+1)$  is S1, the light-emitting data are stored in the range of from R(2, 1) to R(2, 6n-1), when  $S(3k+2)$  is S2, the light-emitting data are stored in the range of from G(2, 2) to G(2, 6n), and when  $S(3k+3)$  is S3, the light-emitting data are stored in the range of from B(2, 1) to B(2, 6n-1). Next lines are stored in a like manner as the above-stated description for odd lines and even lines.

**[0099]** As a result, as shown in Fig. 14A and Fig. 14B, the light-emitting data of the sub-pixels of the same color is sorted and stored per line for each subfield.

**[0100]** Returning now to Fig. 12, as stated above, although the pixel driver according to the second exemplary embodiment includes a driving transistor, four switching transistors, two capacitors, and two light-emitting elements, the principles of the second exemplary embodiment can be applied to organic light emitting displays having various different types of pixels, and are not limited to being applied to the pixels as shown in Fig. 12.

**[0101]** In other pixels of the organic light emitting display where the principles of the second exemplary embodiment are applied, since the driving transistor drives the organic light emitting elements to emit lights of the same color, the white balance can be controlled by regulating the width and length of the channel of the driving transistor.

**[0102]** For example, although Fig. 13 shows a progressive scan driving of a single scan type of organic light emitting display, the present invention may be applied to a dual scan type, interlaced scan type, or any other suitable scan type of organic light emitting display.

**[0103]** Also, although Fig. 12 shows one pixel including two organic light emitting elements, one pixel in other embodiments may include three organic light emitting elements and emit red, green, and blue lights. In this case, the pixel circuit should be driven with one field divided into three subfields.

**[0104]** According to the present invention, a light-emitting display sorts display data into a form that can be read easily from the memory, and stores and manages the sorted display data thereby reducing the data access time and enhancing the memory efficiency.

## Claims

### 1. A light emitting display device comprising:

a data driver (400) for providing a plurality of data signals over a plurality of data lines (D1-Dm) during a field (1TV) including first (1SF) and second subfields (2SF);

a scan driver (200) for providing a plurality of selecting signals over a plurality of scan lines (S1-Sn);

a light-emitting scan driver (300) for providing a plurality of emission control signals over a plurality of light-emitting scan lines (Ena, Enb), the number of light-emitting scan lines (Ena, Enb) being twice that of the scan lines (S1-Sn); and a plurality of pixels (110) arranged in rows and columns and coupled to the data lines (D1-Dm), the scan lines (S1-Sn) and the light-emitting scan lines (Ena, Enb), each pixel comprising a pixel driver (111, 111') and two adjacent sub-pixels having different colors, wherein each sub-pixel comprises a switch adapted to control emission of the sub-pixel,

each pixel driver being directly connected to the respective switches of a first and a second sub-pixel having the same color and belonging to different pixels of the same row,

and the control terminals of the respective switches of the first and the second sub-pixel being connected to a different one of two light-emitting scan lines of the row, such that the number of sub-pixels of each row is twice that of the data lines (D1-Dm),

the display device being adapted to time-divisionally provide for each pixel, during the different subfields (1SF, 2SF), two data signals via the corresponding data line and pixel driver to the first and the second sub-pixel; and

a memory (500) for storing image data, wherein the image data is divided into data for the first and second subfields (1 SF, 2SF), wherein the image data includes data corresponding to the two data signals, the light emitting display device being adapted to store the

image data as sets of R, G, and B data together in the memory (500) for the first and second subfields (1SF, 2SF) arranged according to a sequence of light-emitting driving.

### 2. A light emitting display device comprising:

a data driver (400) for providing a plurality of data signals over a plurality of data lines (D1-Dm) during a field (1TV) including first (1SF) and second subfields (2SF);

a scan driver (200) for providing a plurality of selecting signals over a plurality of scan lines (S1-Sn);

a light-emitting scan driver (300) for providing a plurality of emission control signals over a plurality of light-emitting scan lines (Ena, Enb), the number of light-emitting scan lines (Ena, Enb) being twice that of the scan lines (S1-Sn); and a plurality of pixels (110) arranged in rows and columns and coupled to the data lines (D1-Dm), the scan lines (S1-Sn) and the light-emitting scan lines (Ena, Enb), each pixel comprising a pixel driver (111, 111') and two adjacent sub-pixels having different colors, wherein each sub-pixel comprises a switch adapted to control emission of the sub-pixel,

each pixel driver being directly connected to the respective switches of the sub-pixels of the pixel, and the control terminals of the respective switches of the two sub-pixels of the pixel being connected to a different one of two light-emitting scan lines of the row, such that the number of sub-pixels of each row is twice that of the data lines (D1-Dm),

the display device being adapted to time-divisionally provide for each pixel, during the different subfields (1SF, 2SF), two data signals via the corresponding data line and pixel driver to the sub-pixels of the pixel; and

a memory (500) for storing image data, wherein the image data is divided into data for the first and second subfields (1SF, 2SF), wherein the image data includes data corresponding to the two data signals, the light emitting display device being adapted to store the image data as sets of R, G, and B data together in the memory (500) for the first and second subfields (1SF, 2SF) arranged according to a sequence of light-emitting driving.

### 3. The light emitting display device of one of the claims 1 or 2, wherein the light emitting display device is further adapted to store the arranged data in the memory (500) according to a predetermined sequence of reading the data.

### 4. A method for operating the light emitting display de-

vice of one of the claims 1 or 2, the method comprising:

- a) dividing the display data of a display image into data for the first and second subfields, wherein the display data includes data corresponding to the two data signals;
- b) arranging the data for the first and second subfields according to a sequence of light-emitting driving;
- c) storing the arranged data in a memory (500) as sets of R, G, and B data together, and
- d) during the first and second subfield applying the stored data of that subfield to the plurality of data lines (D1-Dm) and sequentially providing a plurality of selecting signals over the plurality of scan lines (S1-Sn) thereby time-divisionally providing, for each pixel, during each subfield, a data signal via the corresponding data line to the pixel driver
- e) providing a plurality of emission control signals over the plurality of light-emitting scan lines (Ena, Enb) for controlling the switches of the sub-pixels such that each pixel driver supplies the received data signals to the corresponding first and second sub-pixel during the first and second subfield, respectively.

5. The method as claimed in claim 4, wherein the arranged data of c) are stored according to a predetermined sequence of reading the data from the memory (500).

#### Patentansprüche

1. Eine lichtemittierende Anzeigevorrichtung, umfassend:

einen Datentreiber (400) zum Bereitstellen einer Vielzahl von Datensignalen über eine Vielzahl von Datenleitungen (D1-Dm) während eines Feldes (1TV), das erste (1SF) und zweite Unterfelder (2SF) beinhaltet;

einen Abtasttreiber (200) zum Bereitstellen einer Vielzahl von Auswahlsignalen über eine Vielzahl von Abtastleitungen (S1-Sn);

einen Lichtemissionsabtasttreiber (300) zum Bereitstellen einer Vielzahl von Emissionssteuersignalen über eine Vielzahl von Lichtemissionsabtastleitungen (Ena, Enb), wobei die Anzahl an Lichtemissionsabtastleitungen (Ena, Enb) das Zweifache derjenigen der Abtastleitungen (S1-Sn) beträgt; und

eine Vielzahl von in Zeilen und Spalten angeordneten und mit den Datenleitungen (D1-Dm), den Abtastleitungen (S1-Sn) und den Lichtemissionsabtastleitungen (Ena, Enb) verbundenen

Pixeln (110), wobei jedes Pixel einen Pixeltreiber (111, 111') sowie zwei benachbarte Unterpixel, die verschiedene Farben aufweisen, umfasst, wobei jedes Unterpixel einen Schalter umfasst, der dazu ausgelegt ist, die Emission des Unterpixels zu steuern, wobei jeder Pixeltreiber direkt mit den jeweiligen Schaltern eines ersten und eines zweiten Unterpixels, die dieselbe Farbe aufweisen und zu verschiedenen Pixeln derselben Zeile gehören, verbunden ist und die Steueranschlüsse der jeweiligen Schalter des ersten und des zweiten Unterpixels mit einer verschiedenen von zwei Lichtemissionsabtastleitungen der Zeile verbunden sind, so dass die Anzahl an Unterpixeln jeder Zeile das Zweifache derjenigen der Datenleitungen (D1-Dm) beträgt, wobei die Anzeigevorrichtung dazu ausgelegt ist, für jedes Pixel während der verschiedenen Unterfelder (1SF, 2SF) dem ersten und dem zweiten Unterpixel zeitgeteilt zwei Datensignale über die entsprechende Datenleitung und den entsprechenden Pixeltreiber bereitzustellen; und

einen Speicher (500) zum Speichern von Bilddaten, wobei die Bilddaten in Daten für die ersten und zweiten Unterfelder (1SF, 2SF) unterteilt sind, wobei die Bilddaten Daten beinhalten, die den zwei Datensignalen entsprechen, wobei die lichtemittierende Anzeigevorrichtung dazu ausgelegt ist, die Bilddaten als Sätze von R-, G- und B-Daten für die ersten und zweiten Unterfelder (1SF, 2SF) zusammen in dem Speicher (500) gemäß einer Abfolge von Lichtemissionssteuerung angeordnet zu speichern.

2. Eine lichtemittierende Anzeigevorrichtung, umfassend:

einen Datentreiber (400) zum Bereitstellen einer Vielzahl von Datensignalen über eine Vielzahl von Datenleitungen (D1-Dm) während eines Feldes (1TV), das erste (1SF) und zweite Unterfelder (2SF) beinhaltet;

einen Abtasttreiber (200) zum Bereitstellen einer Vielzahl von Auswahlsignalen über eine Vielzahl von Abtastleitungen (S1-Sn);

einen Lichtemissionsabtasttreiber (300) zum Bereitstellen einer Vielzahl von Emissionssteuersignalen über eine Vielzahl von Lichtemissionsabtastleitungen (Ena, Enb), wobei die Anzahl an Lichtemissionsabtastleitungen (Ena, Enb) das Zweifache derjenigen der Abtastleitungen (S1-Sn) beträgt; und

eine Vielzahl von in Zeilen und Spalten angeordneten und mit den Datenleitungen (D1-Dm),

- den Abtastleitungen (S1-Sn) und den Lichtemissionsabtastleitungen (Ena, Enb) verbundenen Pixeln (110), wobei jedes Pixel einen Pixeltreiber (111, 111') sowie zwei benachbarte Unterpixel, die verschiedene Farben aufweisen, umfasst, wobei jedes Unterpixel einen Schalter umfasst, der dazu ausgelegt ist, die Emission des Unterpixels zu steuern, wobei jeder Pixeltreiber direkt mit den jeweiligen Schaltern der Unterpixel des Pixels verbunden ist und die Steueranschlüsse der jeweiligen Schalter der zwei Unterpixel des Pixels mit einer verschiedenen von zwei Lichtemissionsabtastleitungen der Zeile verbunden sind, so dass die Anzahl an Unterpixeln jeder Zeile das Zweifache derjenigen der Datenleitungen (D1-Dm) beträgt, wobei die Anzeigevorrichtung dazu ausgelegt ist, für jedes Pixel während der verschiedenen Unterfelder (1SF, 2SF) den Unterpixeln des Pixels zeitgeteilt zwei Datensignale über die entsprechende Datenleitung und den entsprechenden Pixeltreiber bereitzustellen; und einen Speicher (500) zum Speichern von Bilddaten, wobei die Bilddaten in Daten für die ersten und zweiten Unterfelder (1SF, 2SF) unterteilt sind, wobei die Bilddaten Daten beinhalten, die den zwei Datensignalen entsprechen, wobei die lichtemittierende Anzeigevorrichtung dazu ausgelegt ist, die Bilddaten als Sätze von R-, G- und B-Daten für die ersten und zweiten Unterfelder (1SF, 2SF) zusammen in dem Speicher (500) gemäß einer Abfolge von Lichtemissionsansteuerung angeordnet zu speichern.
3. Die lichtemittierende Anzeigevorrichtung nach einem der Ansprüche 1 oder 2, wobei die lichtemittierende Anzeigevorrichtung ferner dazu ausgelegt ist, die angeordneten Daten gemäß einer vorbestimmten Abfolge des Lesens der Daten in dem Speicher (500) zu speichern.
4. Ein Verfahren zum Betreiben der lichtemittierenden Anzeigevorrichtung nach einem der Ansprüche 1 oder 2, wobei das Verfahren Folgendes umfasst:
- Unterteilen der Anzeigedaten eines Anzeigebildes in Daten für die ersten und zweiten Unterfelder, wobei die Anzeigedaten Daten beinhalten, die den zwei Datensignalen entsprechen;
  - Anordnen der Daten für die ersten und zweiten Unterfelder gemäß einer Abfolge von Lichtemissionsansteuerung;
  - Speichern der angeordneten Daten als Sätze von R-, G- und B-Daten zusammen in einem Speicher (500) und
  - während des ersten und zweiten Unterfeldes,

Anlegen der gespeicherten Daten dieses Unterfeldes an die Vielzahl von Datenleitungen (D1-Dm) und sequenzielles Bereitstellen einer Vielzahl von Auswahlsignalen über die Vielzahl von Abtastleitungen (S1-Sn), wodurch für jedes Pixel dem Pixeltreiber während jedes Unterfeldes zeitgeteilt ein Datensignal über die entsprechende Datenleitung bereitgestellt wird

e) Bereitstellen einer Vielzahl von Emissionssteuersignalen über die Vielzahl von Lichtemissionsabtastleitungen (Ena, Enb) zum Steuern der Schalter der Unterpixel, so dass jeder Pixeltreiber die empfangenen Datensignale dem entsprechenden ersten und zweiten Unterpixel während des ersten beziehungsweise zweiten Unterfeldes bereitstellt.

5. Das Verfahren nach Anspruch 4, wobei die angeordneten Daten von c) gemäß einer vorbestimmten Abfolge des Lesens der Daten aus dem Speicher (500) gespeichert werden.

#### Revendications

1. Dispositif d'affichage à émission de lumière comprenant :

un circuit d'attaque (400) de données destiné à fournir une pluralité de signaux de données sur une pluralité de lignes (D1 à Dm) de données pendant une image (1TV) incluant des première (1SF) et seconde (2SF) sous-images ;

un circuit d'attaque (200) de balayage destiné à fournir une pluralité de signaux de sélection sur une pluralité de lignes (S1 à Sn) de balayage ;

un circuit d'attaque (300) de balayage d'émission de lumière destiné à fournir une pluralité de signaux de commande d'émission sur une pluralité de lignes (Ena, Enb) de balayage d'émission de lumière, le nombre de lignes (Ena, Enb) de balayage d'émission de lumière étant deux fois celui des lignes (S1 à Sn) de balayage ; et une pluralité de pixels (110) agencés en rangées et en colonnes et raccordés aux lignes (D1 à Dm) de données, aux lignes (S1 à Sn) de balayage et aux lignes (Ena, Enb) de balayage d'émission de lumière, chaque pixel comprenant un circuit d'attaque (111, 111') de pixel et deux sous-pixels adjacents ayant des couleurs différentes, dans lequel chaque sous-pixel comprend un interrupteur apte à commander l'émission du sous-pixel, chaque circuit d'attaque de sous-pixel étant connecté directement aux interrupteurs respectifs d'un premier et d'un second sous-pixel ayant la même couleur et appartenant à des pixels différents de la même rangée,

et les bornes de commande des interrupteurs respectifs du premier et du second sous-pixel étant connectées à l'une, différente, de deux lignes de balayage d'émission de lumière de la rangée, de sorte que le nombre de sous-pixels

de chaque rangée est deux fois celui des lignes (D1 à Dm) de données, le dispositif d'affichage étant apte à fournir, au premier et au second sous-pixel, de façon répartie dans le temps, pour chaque pixel, pendant les différentes sous-images (1SF, 2SF), deux signaux de données via la ligne de données et le circuit d'attaque de pixel, correspondants ; et une mémoire (500) destinée à mémoriser des données d'image,

dans lequel les données d'images sont divisées en données d'image pour les première et seconde sous-images (1SF, 2SF), dans lequel les données d'image incluent des données correspondant aux deux signaux de données, le dispositif d'affichage à émission de lumière étant apte à mémoriser conjointement les données d'image sous forme d'ensembles de données de rouge, vert et bleu (R, G, et B) dans la mémoire (500) pour les première et seconde sous-images (1SF, 2SF) agencées suivant une séquence d'attaque d'émission de lumière.

2. Dispositif d'affichage à émission de lumière comprenant :

un circuit d'attaque (400) de données destiné à fournir une pluralité de signaux de données sur une pluralité de lignes (D1 à Dm) de données pendant une image (1TV) incluant des première (1SF) et seconde (2SF) sous-images ;

un circuit d'attaque (200) de balayage destiné à fournir une pluralité de signaux de sélection sur une pluralité de lignes (S1 à Sn) de balayage ;

un circuit d'attaque (300) de balayage d'émission de lumière destiné à fournir une pluralité de signaux de commande d'émission sur une pluralité de lignes (Ena, Enb) de balayage d'émission de lumière, le nombre de lignes (Ena, Enb) de balayage d'émission de lumière étant deux fois celui des lignes (S1 à Sn) de balayage ; et une pluralité de pixels (110) agencés en rangées et en colonnes et raccordés aux lignes (D1 à Dm) de données, aux lignes (S1 à Sn) de balayage et aux lignes (Ena, Enb) de balayage d'émission de lumière, chaque pixel comprenant un circuit d'attaque (111, 111') de pixel et deux sous-pixels adjacents ayant des couleurs différentes, dans lequel chaque sous-pixel comprend un interrupteur apte à commander l'émission du sous-pixel,

chaque circuit d'attaque de pixel étant connecté directement aux interrupteurs respectifs des

sous-pixels du pixel, et les bornes de commande des interrupteurs respectifs des deux sous-pixels du pixel étant connectées à l'une, différente, de deux lignes de balayage d'émission de lumière de la rangée, de sorte que le nombre de sous-pixels de chaque rangée est deux fois celui des lignes (D1 à Dm) de données,

le dispositif d'affichage étant apte à fournir, aux sous-pixels du pixel, de façon répartie dans le temps, pour chaque pixel, pendant les différentes sous-images (1SF, 2SF), deux signaux de données via la ligne de données et le circuit d'attaque de pixel, correspondants ; et

une mémoire (500) destinée à mémoriser des données d'image,

dans lequel les données d'images sont divisées en données pour les première et seconde sous-images (1SF, 2SF), dans lequel les données d'image incluent des données correspondant aux deux signaux de données, le dispositif d'affichage à émission de lumière étant apte à mémoriser conjointement les données d'image sous forme d'ensembles de données de R, G et B dans la mémoire (500) pour les première et seconde sous-images (1SF, 2SF) agencées suivant une séquence d'attaque d'émission de lumière.

3. Dispositif d'affichage à émission de lumière selon l'une des revendications 1 et 2, dans lequel le dispositif d'affichage à émission de lumière est en outre apte à mémoriser dans la mémoire (500) les données agencées selon une séquence prédéterminée de lecture des données.

4. Procédé de mise en oeuvre du dispositif d'affichage à émission de lumière selon l'une des revendications 1 et 2, le procédé comprenant :

a) la répartition des données d'affichage d'une image d'affichage en données pour les première et seconde sous-images, dans lequel les données d'affichage incluent des données correspondant aux deux signaux de données ;

b) l'agencement des données pour les première et seconde sous-images selon une séquence d'attaque d'émission de lumière ;

c) la mémorisation conjointe dans une mémoire (500) des données agencées sous forme d'ensembles de données de R, G et B ; et

d) pendant les première et seconde sous-images, l'application, à la pluralité de lignes (D1 à Dm) de donnée, des données mémorisées de cette sous-image et la fourniture séquentielle d'une pluralité de signaux de sélection sur la pluralité de lignes (S1 à Sn) de balayage, en fournissant ainsi, au circuit d'attaque de pixel, de manière répartie dans le temps, pour chaque

pixel, pendant chaque sous-image, un signal de donnée via la ligne de donnée correspondante ;  
e) la fourniture d'une pluralité de signaux de commande d'émission sur la pluralité de lignes (Ena, Enb) de balayage d'émission de lumière pour commander les interrupteurs des sous-pixels, de façon que chacun de ces circuits d'attaque de pixel délivre les signaux de donnée reçus, respectivement, aux premier et second sous-pixels correspondants pendant les première et seconde sous-images.

5. Procédé selon la revendication 4, dans lequel les données agencées de c) sont mémorisées suivant une séquence prédéterminée de lecture des données dans la mémoire (500).

20

25

30

35

40

45

50

55

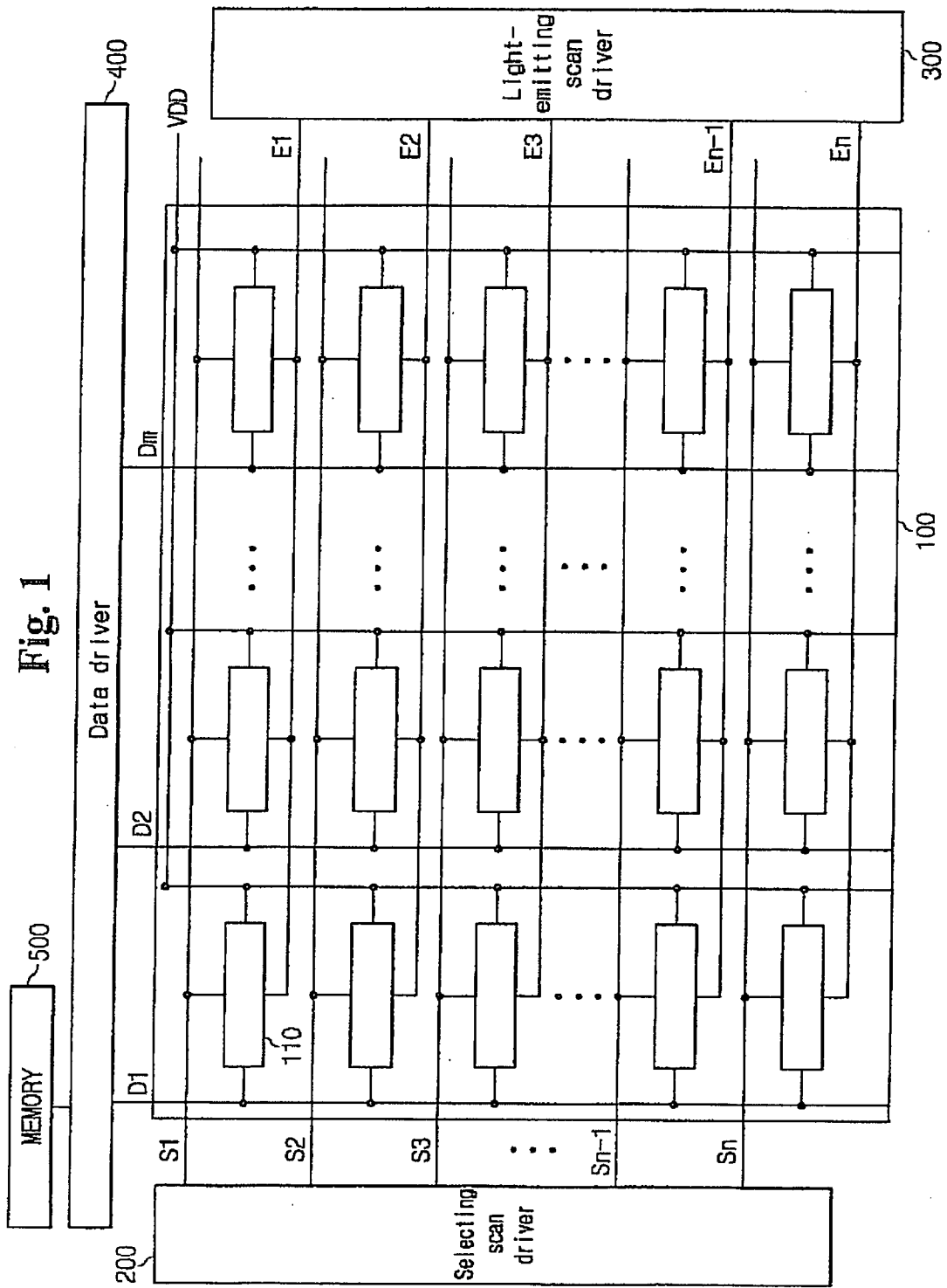

Fig. 2A

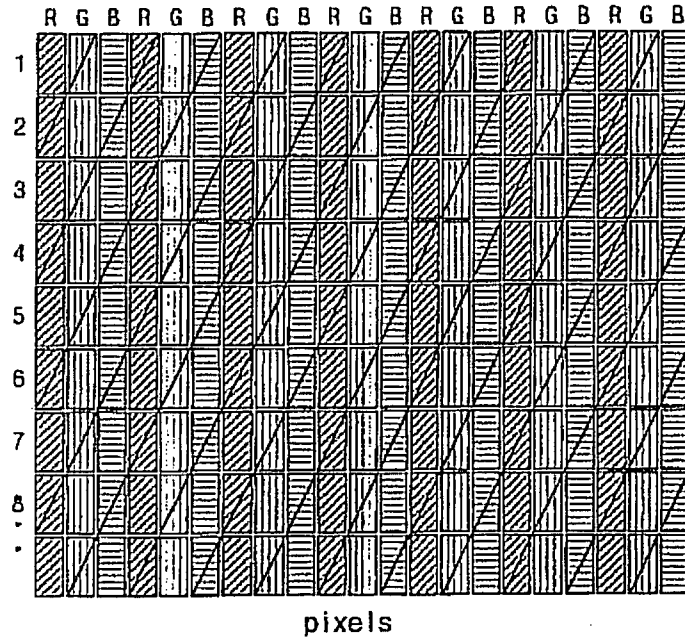

Fig. 2B

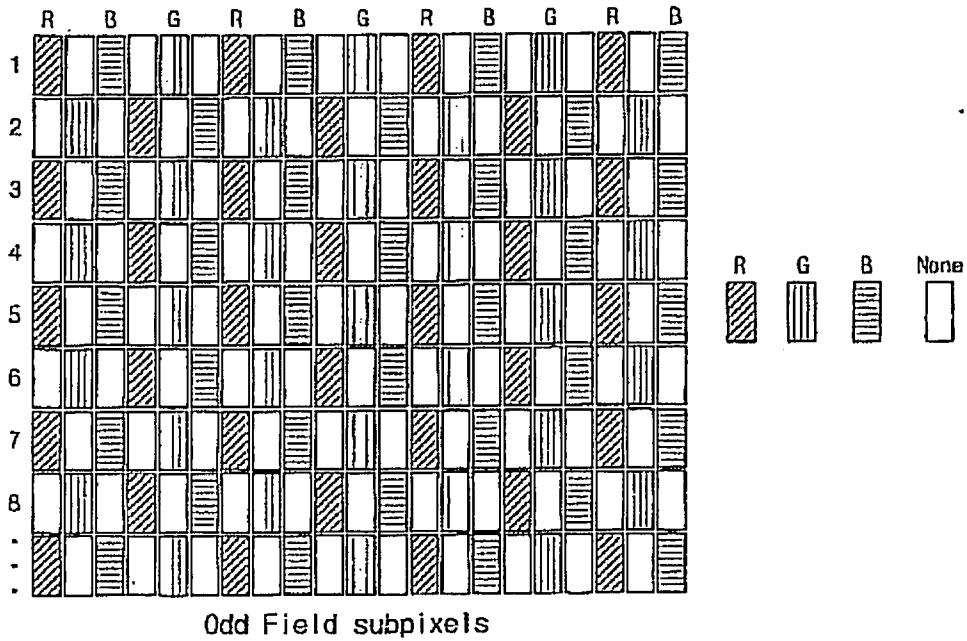

Fig. 2C

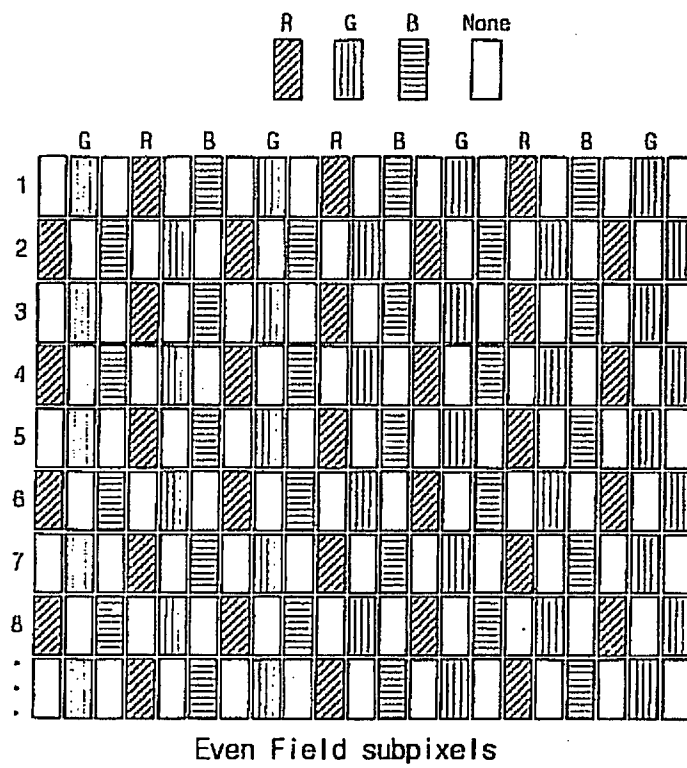

Fig. 3

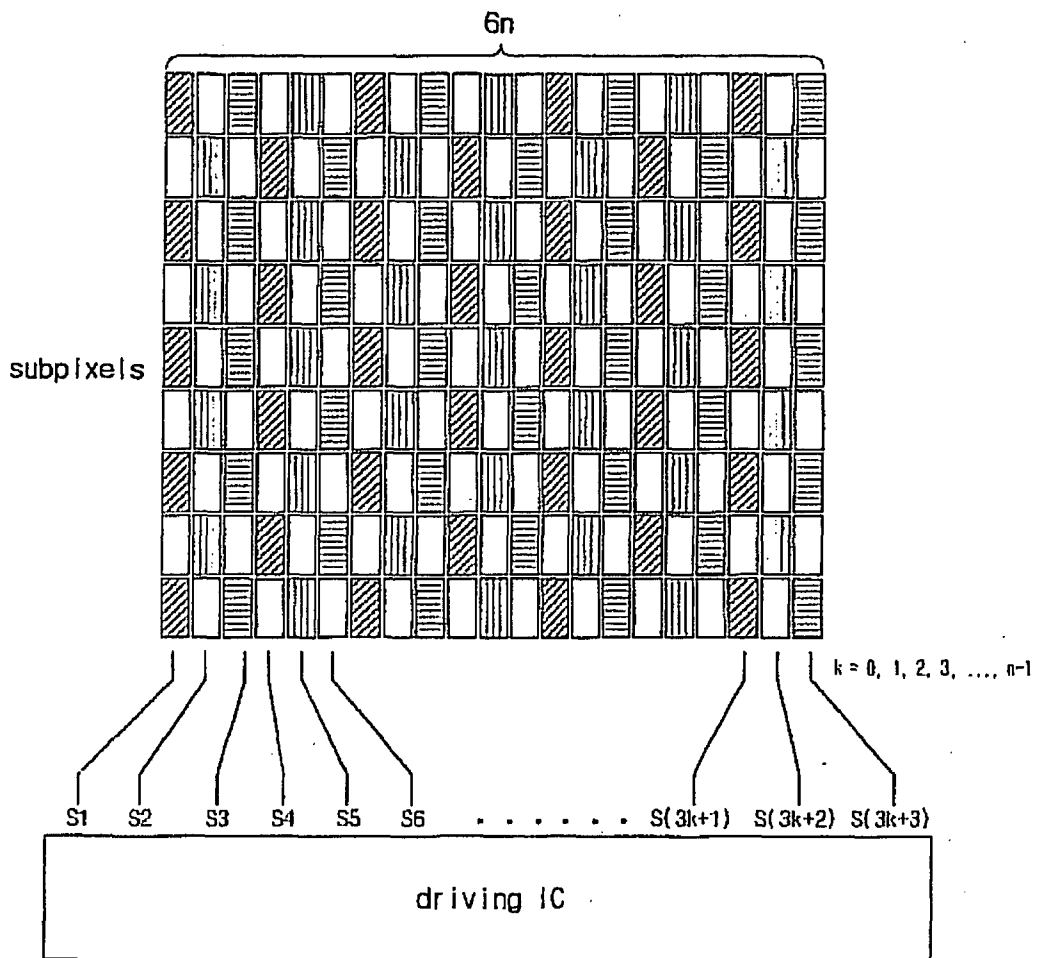

Fig. 4

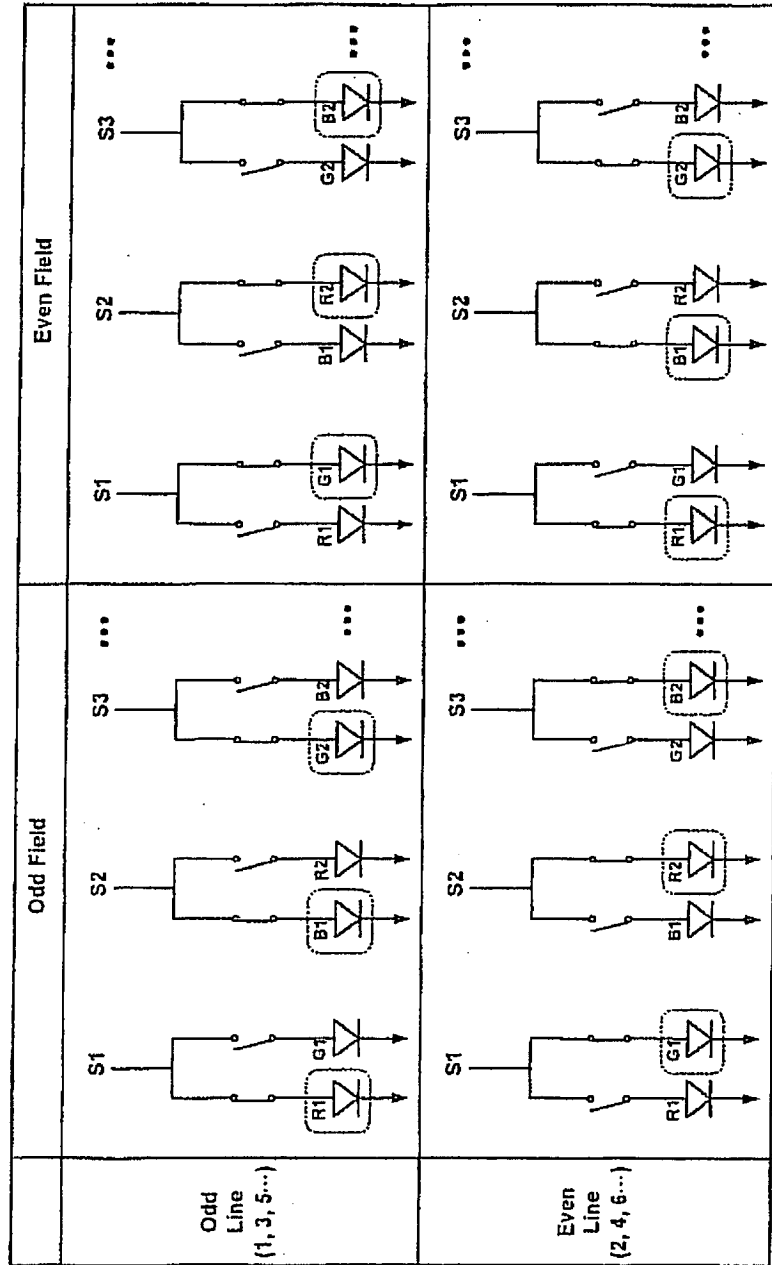



Fig. 6

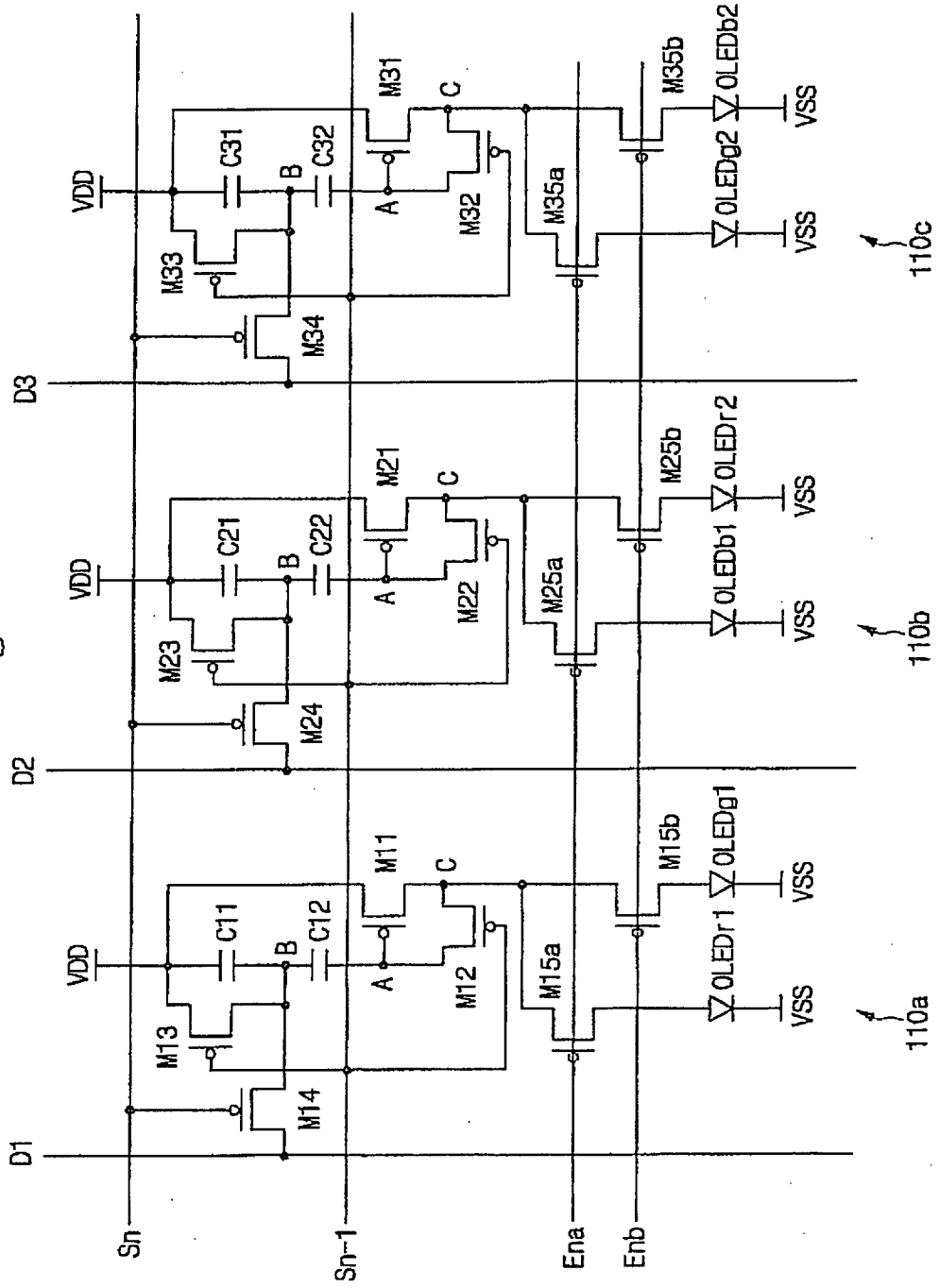

Fig. 7

1 Line	$R(1, 1)$	$R(1, 2)$	$R(1, 3)$	...	$R(1, 6n)$
	$G(1, 1)$	$G(1, 2)$	$G(1, 3)$	...	$G(1, 6n)$
	$B(1, 1)$	$B(1, 2)$	$B(1, 3)$	...	$B(1, 6n)$
2 Line	$R(2, 1)$	$R(2, 2)$	$R(2, 3)$	...	$R(2, 6n)$
	$G(2, 1)$	$G(2, 2)$	$G(2, 3)$	...	$G(2, 6n)$
	$B(2, 1)$	$B(2, 2)$	$B(2, 3)$	...	$B(2, 6n)$
3 Line	$R(3, 1)$	$R(3, 2)$	$R(3, 3)$	...	$R(3, 6n)$
	$G(3, 1)$	$G(3, 2)$	$G(3, 3)$	...	$G(3, 6n)$
	$B(3, 1)$	$B(3, 2)$	$B(3, 3)$	...	$B(3, 6n)$
4 Line	$R(4, 1)$	$R(4, 2)$	$R(4, 3)$	...	$R(4, 6n)$
	$G(4, 1)$	$G(4, 2)$	$G(4, 3)$	...	$G(4, 6n)$
	$B(4, 1)$	$B(4, 2)$	$B(4, 3)$	...	$B(4, 6n)$
.	.	.	.	.	.
.	.	.	.	.	.
.	.	.	.	.	.

6n

Fig. 8A

Odd Field

R(1, 1)	B(1, 1)	G(1, 2)	R(1, 3)	B(1, 3)	G(1, 4)	R(1, 5)	B(1, 5)	G(1, 6)
G(2, 1)	R(2, 2)	B(2, 2)	G(2, 3)	R(2, 4)	B(2, 4)	G(2, 5)	R(2, 6)	B(2, 6)
R(3, 1)	B(3, 1)	G(3, 2)	R(3, 3)	B(3, 3)	G(3, 4)	R(3, 5)	B(3, 5)	G(3, 6)
G(4, 1)	R(4, 2)	B(4, 2)	G(4, 3)	R(4, 4)	B(4, 4)	G(4, 5)	R(4, 6)	B(4, 6)

R(1, 1)	B(1, 1)	G(1, 2)	R(1, 3)	B(1, 3)	G(1, 4)	R(1, 5)	B(1, 5)	G(1, 6)
G(2, 1)	R(2, 2)	B(2, 2)	G(2, 3)	R(2, 4)	B(2, 4)	G(2, 5)	R(2, 6)	B(2, 6)
R(3, 1)	B(3, 1)	G(3, 2)	R(3, 3)	B(3, 3)	G(3, 4)	R(3, 5)	B(3, 5)	G(3, 6)
G(4, 1)	R(4, 2)	B(4, 2)	G(4, 3)	R(4, 4)	B(4, 4)	G(4, 5)	R(4, 6)	B(4, 6)

Fig. 8B

Even Field

G(1, 1)	R(1, 2)	B(1, 2)	G(1, 3)	R(1, 4)	B(1, 4)	G(1, 5)	R(1, 6)	B(1, 6)
R(2, 1)	B(2, 1)	G(2, 2)	R(2, 3)	B(2, 3)	G(2, 4)	R(2, 5)	B(2, 5)	G(2, 6)
G(3, 1)	R(3, 2)	B(3, 2)	G(3, 3)	R(3, 4)	B(3, 4)	G(3, 5)	R(3, 6)	B(3, 6)
R(4, 1)	B(4, 1)	G(4, 2)	R(4, 3)	B(4, 3)	G(4, 4)	R(4, 5)	B(4, 5)	G(4, 6)

G(1, 1)	R(1, 2)	B(1, 2)	G(1, 3)	R(1, 4)	B(1, 4)	G(1, 5)	R(1, 6)	B(1, 6)
R(2, 1)	B(2, 1)	G(2, 2)	R(2, 3)	B(2, 3)	G(2, 4)	R(2, 5)	B(2, 5)	G(2, 6)
G(3, 1)	R(3, 2)	B(3, 2)	G(3, 3)	R(3, 4)	B(3, 4)	G(3, 5)	R(3, 6)	B(3, 6)
R(4, 1)	B(4, 1)	G(4, 2)	R(4, 3)	B(4, 3)	G(4, 4)	R(4, 5)	B(4, 5)	G(4, 6)

Fig. 9A

	k	0	1	2	...	n-1
1 Line	$S(3k+1)$	$R(1, 1)$	$R(1, 3)$	$R(1, 5)$	...	$R(1, 6n-1)$
	$S(3k+2)$	$B(1, 1)$	$B(1, 3)$	$B(1, 5)$	...	$B(1, 6n-1)$
	$S(3k+3)$	$G(1, 2)$	$G(1, 4)$	$G(1, 6)$	...	$G(1, 6n)$
2 Line	$S(3k+1)$	$G(2, 1)$	$G(2, 3)$	$G(2, 5)$	...	$G(2, 6n-1)$
	$S(3k+2)$	$R(2, 2)$	$R(2, 4)$	$R(2, 6)$	...	$R(2, 6n)$
	$S(3k+3)$	$B(2, 2)$	$B(2, 4)$	$B(2, 6)$	...	$B(2, 6n)$
3 Line	$S(3k+1)$	$R(3, 1)$	$R(3, 3)$	$R(3, 5)$	...	$R(3, 6n-1)$
	$S(3k+2)$	$B(3, 1)$	$B(3, 3)$	$B(3, 5)$	...	$B(3, 6n-1)$
	$S(3k+3)$	$G(3, 2)$	$G(3, 4)$	$G(3, 6)$	...	$G(3, 6n)$
4 Line	$S(3k+1)$	$G(4, 1)$	$G(4, 3)$	$G(4, 5)$	...	$G(4, 6n-1)$
	$S(3k+2)$	$R(4, 2)$	$R(4, 4)$	$R(4, 6)$	...	$R(4, 6n)$
	$S(3k+3)$	$B(4, 2)$	$B(4, 4)$	$B(4, 6)$	...	$B(4, 6n)$
.	.	.	.	.	.	.
.	.	.	.	.	.	.

3n

Fig. 9B

	k	0	1	2	...	n-1
1 Line	$S(3k+1)$	$G(1, 1)$	$G(1, 3)$	$G(1, 5)$	...	$G(1, 6n-1)$
	$S(3k+2)$	$R(1, 2)$	$R(1, 4)$	$R(1, 6)$	...	$R(1, 6n)$
	$S(3k+3)$	$B(1, 2)$	$B(1, 4)$	$B(1, 6)$	...	$B(1, 6n)$
2 Line	$S(3k+1)$	$R(2, 1)$	$R(2, 3)$	$R(2, 5)$	...	$R(2, 6n-1)$
	$S(3k+2)$	$B(2, 1)$	$B(2, 3)$	$B(2, 5)$	...	$B(2, 6n-1)$
	$S(3k+3)$	$G(2, 2)$	$G(2, 4)$	$G(2, 6)$	...	$G(2, 6n)$
3 Line	$S(3k+1)$	$G(3, 1)$	$G(3, 3)$	$G(3, 5)$	...	$G(3, 6n-1)$
	$S(3k+2)$	$R(3, 2)$	$R(3, 4)$	$R(3, 6)$	...	$R(3, 6n)$
	$S(3k+3)$	$B(3, 2)$	$B(3, 4)$	$B(3, 6)$	...	$B(3, 6n)$
4 Line	$S(3k+1)$	$R(4, 1)$	$R(4, 3)$	$R(4, 5)$	...	$R(4, 6n-1)$
	$S(3k+2)$	$B(4, 1)$	$B(4, 3)$	$B(4, 5)$	...	$B(4, 6n-1)$
	$S(3k+3)$	$G(4, 2)$	$G(4, 4)$	$G(4, 6)$	...	$G(4, 6n)$
.	.	.	.	.	.	.
.	.	.	.	.	.	.

3n

Fig. 10

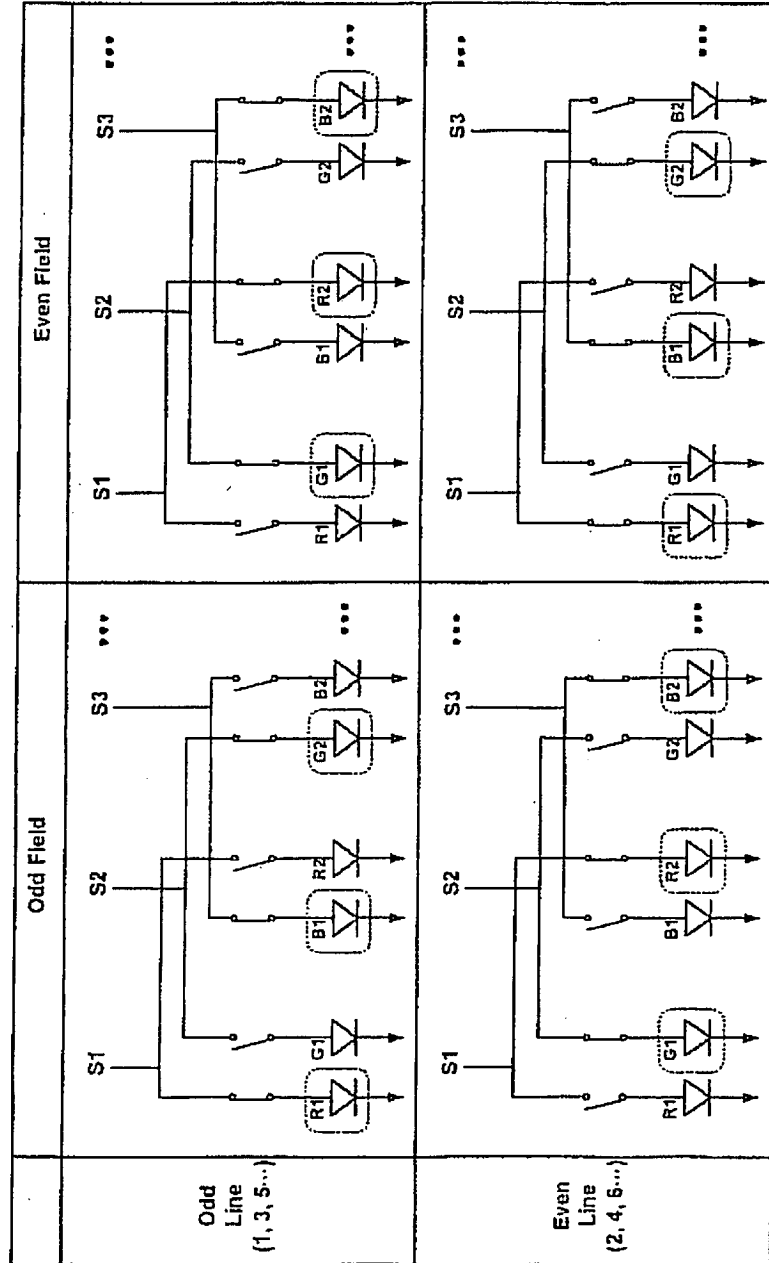

Fig. 11

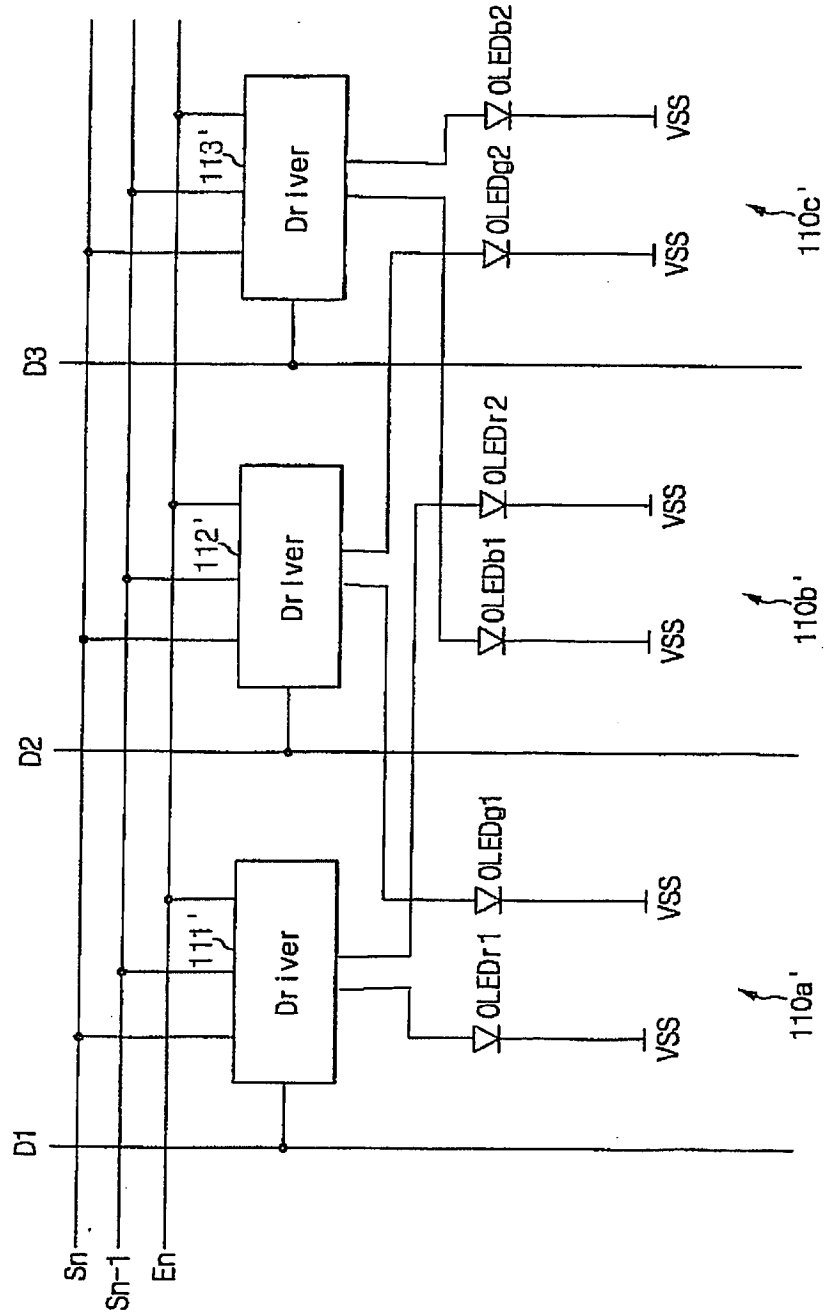

Fig. 12

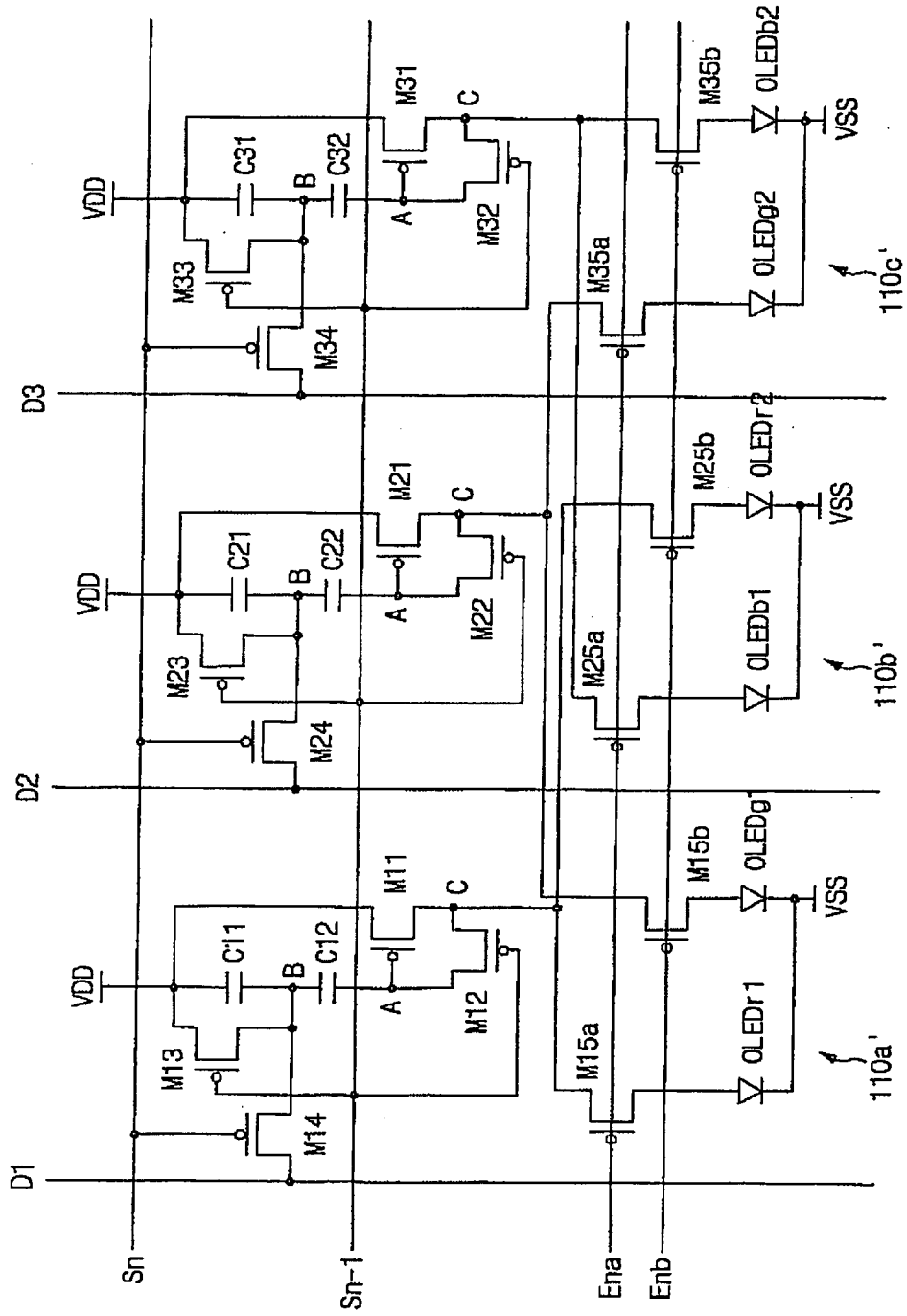

Fig. 13

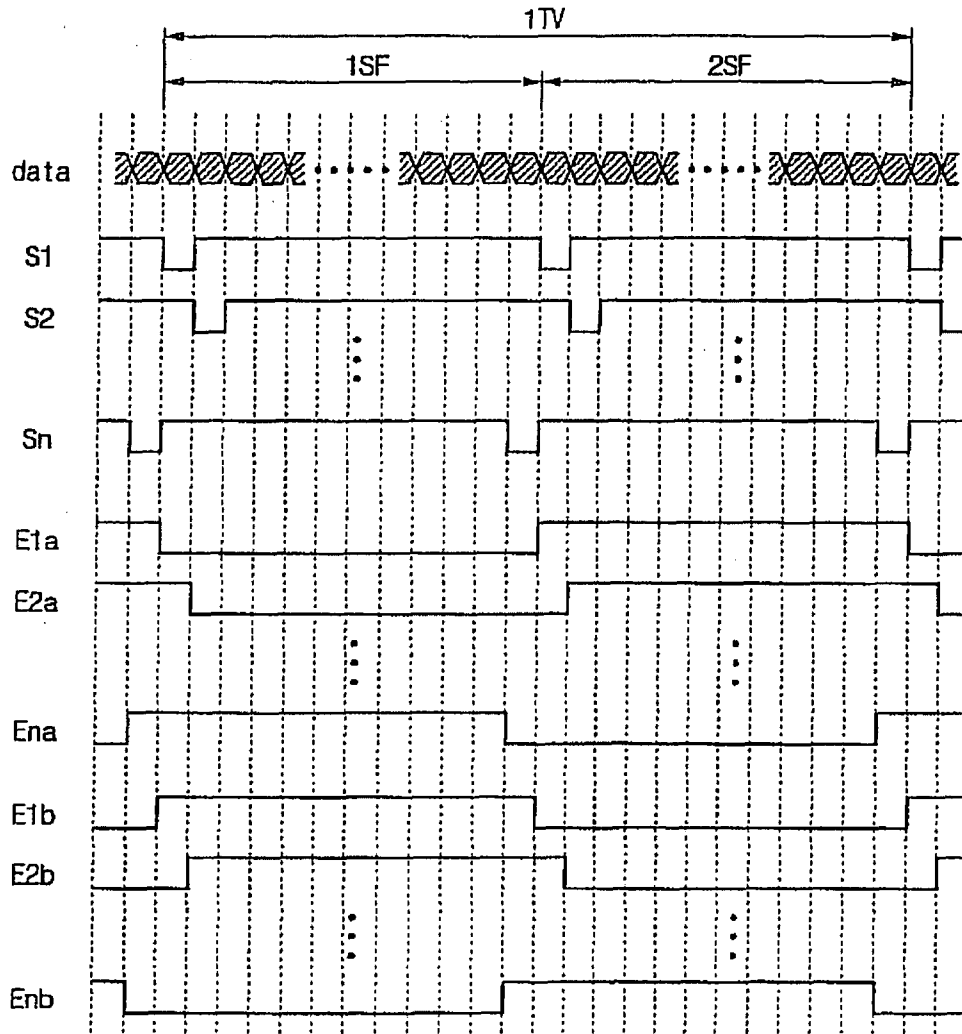

Fig. 14A

	k	0	1	2	...	n-1
1 Line	$S(3k+1)$	$R(1, 1)$	$R(1, 3)$	$R(1, 5)$	...	$R(1, 6n-1)$
	$S(3k+2)$	$G(1, 2)$	$G(1, 4)$	$G(1, 6)$	...	$G(1, 6n)$
	$S(3k+3)$	$B(1, 1)$	$B(1, 3)$	$B(1, 5)$	...	$B(1, 6n-1)$
2 Line	$S(3k+1)$	$R(2, 2)$	$R(2, 4)$	$R(2, 6)$	...	$R(2, 6n)$
	$S(3k+2)$	$G(2, 1)$	$G(2, 3)$	$G(2, 5)$	...	$G(2, 6n-1)$
	$S(3k+3)$	$B(2, 2)$	$B(2, 4)$	$B(2, 6)$	...	$B(2, 6n)$
3 Line	$S(3k+1)$	$R(3, 1)$	$R(3, 3)$	$R(3, 5)$	...	$R(3, 6n)$
	$S(3k+2)$	$G(3, 2)$	$G(3, 4)$	$G(3, 6)$	...	$G(3, 6n-1)$
	$S(3k+3)$	$B(3, 1)$	$B(3, 3)$	$B(3, 5)$	...	$B(3, 6n)$
4 Line	$S(3k+1)$	$R(4, 2)$	$R(4, 4)$	$R(4, 6)$	...	$R(4, 6n-1)$
	$S(3k+2)$	$G(4, 1)$	$G(4, 3)$	$G(4, 5)$	...	$G(4, 6n)$
	$S(3k+3)$	$B(4, 2)$	$B(4, 4)$	$B(4, 6)$	...	$B(4, 6n-1)$
.	.	.	.	.	.	.
.	.	.	.	.	.	.
.	.	.	.	.	.	.

3n

Fig. 14B

	k	0	1	2	...	n-1
1 Line	$S(3k+1)$	$R(1, 2)$	$R(1, 4)$	$R(1, 6)$	...	$R(1, 6n)$
	$S(3k+2)$	$G(1, 1)$	$G(1, 3)$	$G(1, 5)$	...	$G(1, 6n-1)$
	$S(3k+3)$	$B(1, 2)$	$B(1, 4)$	$B(1, 6)$	...	$B(1, 6n)$
2 Line	$S(3k+1)$	$R(2, 1)$	$R(2, 3)$	$R(2, 5)$	...	$R(2, 6n-1)$
	$S(3k+2)$	$G(2, 2)$	$G(2, 4)$	$G(2, 6)$	...	$G(2, 6n)$
	$S(3k+3)$	$B(2, 1)$	$B(2, 3)$	$B(2, 5)$	...	$B(2, 6n-1)$
3 Line	$S(3k+1)$	$R(3, 2)$	$R(3, 4)$	$R(3, 6)$	...	$R(3, 6n-1)$
	$S(3k+2)$	$G(3, 1)$	$G(3, 3)$	$G(3, 5)$	...	$G(3, 6n)$
	$S(3k+3)$	$B(3, 2)$	$B(3, 4)$	$B(3, 6)$	...	$B(3, 6n-1)$
4 Line	$S(3k+1)$	$R(4, 1)$	$R(4, 3)$	$R(4, 5)$	...	$R(4, 6n)$
	$S(3k+2)$	$G(4, 2)$	$G(4, 4)$	$G(4, 6)$	...	$G(4, 6n-1)$
	$S(3k+3)$	$B(4, 1)$	$B(4, 3)$	$B(4, 5)$	...	$B(4, 6n)$
.	.	.	.	.	.	.
.	.	.	.	.	.	.
.	.	.	.	.	.	.

3n

**REFERENCES CITED IN THE DESCRIPTION**

*This list of references cited by the applicant is for the reader's convenience only. It does not form part of the European patent document. Even though great care has been taken in compiling the references, errors or omissions cannot be excluded and the EPO disclaims all liability in this regard.*

**Patent documents cited in the description**

- EP 1441325 A [0006]
- US 6421033 B1 [0007]

专利名称(译)	用于管理发光显示器的显示数据的方法		
公开(公告)号	<a href="#">EP1628285B1</a>	公开(公告)日	2010-03-31
申请号	EP2005107585	申请日	2005-08-18
[标]申请(专利权)人(译)	三星斯笛爱股份有限公司		
申请(专利权)人(译)	三星SDI CO., LTD.		
当前申请(专利权)人(译)	三星移动显示器有限公司.		
发明人	LEE, KYOUNG-SOO, SAMSUNG SDI CO., LTD. SONG, JUNE-YOUNG, SAMSUNG SDI CO., LTD.		
IPC分类号	G09G3/32		
CPC分类号	G09G5/399 G09G3/2022 G09G3/3233 G09G2300/0452 G09G2300/0465 G09G2300/0804 G09G2300/0819 G09G2300/0852 G09G2300/0861 G09G2320/043		
代理机构(译)	hengelhaupt, Jürgen		
优先权	1020040065778 2004-08-20 KR		
其他公开文献	EP1628285A1		
外部链接	<a href="#">Espacenet</a>		

摘要(译)

一种用于使用有机材料的场致发光的发光显示装置的显示数据的存储器管理方法。多个像素各自设置有至少两个子像素以发射不同颜色的光，其中一个场具有至少第一和第二子场被独立地分割和驱动。在一个场期间，对应于基本相同颜色的至少两个数据信号被时分并施加到数据线，并且选择信号被顺序地施加到第一和第二子场的多个扫描线。该方法包括：a) 将对应于显示图像的输入数据划分为用于第一和第二子场的数据，b) 根据发光驱动的顺序排列第一和第二子场的数据，以及c) 存储排列的数据作为基于像素的数据。

