

(19)
(12)

(KR)
(Y1)

(51) 。 Int. Cl.7
G02F 1/136

(45)
(11)
(24)

2004 06 22
20-0353899
2004 06 09

(21) 20-2004-0007429 ()
(22) 2004 03 18
(62) 10-2001-0027225
: 2001 05 18

2001 05 18

(30) JP-P-2000-00147578 2000 05 19 (JP)

(73) 가 가 가 , . 1753

(72) 5-7-1 가 가

(74) :
:

(54)

가 가 . 가 가

1		1	.
2		1	.
3		2	.
4		2	.
5	IPS	1	.
6	IPS	2	.
7	IPS		.
8		1	.
9		1	.
10		2	.
11		2	.
12		3	.
13		3	.
14		4	.
15		4	.
16		5	.
17		5	.
18		6	.
19		6	.
20		7	.
21		7	.
22		8	.
23		8	.
24		9	.
25		9	.
26		10	.
27		10	.
28		11	.

29	11	.
30	12	.
31	12	.
32	13	.
33	13	.
34	14	.
35	14	.
36	15	.
37	15	.
38	16	.
39	16	.
40	17	.
41	17	.
42	18	.
43	18	.
44	19	.
45	19	.
46	20	.
47	20	.
48	21	.
49	21	.
50	22	.
51	22	.
52	23	.
53	23	.
54		.
55 a		.
55 b	55 a	b-b .
56 a	l	.

4 (202) 4 (17), (16), 2 (14), (12), (13), (15) (11)

4 (11), (22), (5), (2), (10), (4), 1 (9) (18)

3 4 (202) (2) (4) 1 2 (201) (202) 가

5 IPS 1 (2) (4) 5 , IPS (aperature ratio) 가

6 IPS TFT 2 : 6 (가

7 IPS (20) (2) (4) (2) (eq (62)) (discrimination) (62) (ui-potential surface)(61))

가 2000-39625 가

IPS 5V 6 가 (aperture ratio) 가

가

가 가 가 가

1 2 1 1 2

2 1 2 1 1 1 1

(notch)

ITO

가

ITO

가

) 8 1 8 9 (101) (1), (2), 8 1 (TFT
 (5), (6), (7) (21) 15 가 (3), (4), (20)
 (19)(comb)
 9 (101) A-A 9 (17), (16), 1 2
 (14), (20) (12), (13), (15) (11) (2), (5), () (10),
 (11), (8), (22), (18)가
 (4), 1 (9)
 (2) (4) 10 μ m (8) (2)
 (8) (4) 5 8 μ m
 (17, 18) 0.2mm (16) 500 1 2
 (9, 14) 0.7mm (12) 1 μ m (15) 1 μ m
 (5) (2) (22) 3000 (11) 500
 8) 1000 (2) 2000 (4) 2000 ()
 (2) (4) (8) (21) (2) (8) ITO (2)
 가 (8) 가 (2) (8) 가 (8) 가
 (2) (4) 가 가 가 가
 (8) (101) (1)
 01) 가 가
 , 2 10 10 11 (102) (1), 10
 (3), (4), (5) (6), (7) (21, 21) (2),
 (102) (20) (19)() 15 10 가
)

11 (TFT (16), 2) (102) A-A 11 (20) 11 2 (17),
 (14), (12), (13), (15) (11)
 (11), (8), (22), (2), (5),
 (4), 1 (9) (18)

10 11 (102) 8 9 (101)
 (102) (21) (102)
 (8)

3 가 12 13 12
 3 (103) (1), (2),
 (3), (4), (5), (6), (7) (21) 12
 (103) (20) (19)(4)

13 (TFT (16), 2) (103) A-A 13 3 (17),
 (14), (12), (13), (15) (11)
 (11), (8), (22), (2), (5),
 (4), 1 (9) (18)

12 13 (103) 8 9 (101)
 (8) (20) (19) : (4) (8)
 (103) (2) (8) (103) (8)
 (4) 가 (20) 가 (20) 가 (2)
 (4) 가 가 (101, 102)

4 (TFT) 14 15 14 (104) (1),
 (2), (3), (4), (5), (6), (7) (21, 21)
 (8) 14 (104) (20) ()

15 (104) A-A 15 4
 15 (20) (17), (16), 2
 (14), (12), (13), (15) (11)
 (11), (8), (22), (2), (5), () (1)
 0), (4), 1 (9) (18)

14 15 (104) 12 13 (103)
 (104) (21) (104)
 (8) (101, 102)

5 가 16 17 16 (105) (1),
 (2), (3), (4), (5), (6), (7), (8) (21)
 16 (105) (19)(4) 15
 가)

17 (105) A-A 17 5
 17 (20) (17), (16), 2
 (14), (12), (13)() (15) (11)
 (11), (8), (22), (2), (5), ()

(10), (4), 1 (9) (18) .

16 17 (105) 12 13 (104) .
 (2) (20) (105) (8) ,
 (20) (20) (8)

(20) (19) (4) (4) 15
 (2) (105) (101)

6 가 18 19 18
 (FET) . 18 (106) (1),
 (2), (3), (4), (5), (6), (7) (21, 21) 15
 18 가) (106) (20) (19)(4) (4)

19 (106) A-A 19 6
 (20) (17), (16), 2
 (14), (12), (13), (15) (11)
 (11), (8), (22), (2), (5), () (1)
 0), (4), 1 (9) (18)

18 19 (106) 16 17 (105)
 (106) (21) (106)

7 가 20 21 20
 (TFT) . 20 (107) (21) ()
 1), (2), (3), (4), (5), (6), (7) (21) ()
 4) (8) 20 (107) (20) ()

21 (107) A-A 21 7
 (20) (17), (16), 2
 (14), (12), (13), (15) (11)
 (11), (8), (22), (2), (5), () (1)
 0), (4), 1 (9) (18)

20 21 (107) 12 13 (103)
 (2) (8) (19) (107) (2) (2)
 (8) (21) (2)
 (107) 가 가 ,
 (20) 가 가 ,
 가 가 ,

8 8 22 23 22
 (3), (4), (5), (6), (7) (108) (1), (2), ()
 8)) 22 (108) (20) (21, 21) (4)

23 (108) A-A 23 8
 (20) (17), (16), 2
 (14), (12), (13), (15) (11)

0), (11), (8), (22), (2), (5), () (1)
 (4), 1 (9) (18) .

22 23 (108) 20 21 (107)
 (108) (21) (108) .
 (8)

9 가 24 25 24
 9 24 (109) (1), (2),
 (3), (4), (5), (6), (7) (21) (8) 3
 (three-pole) 15 가) (109) (19)((2)

25 (109) A-A 25 9
 25 , (20) (17), (16), 2
 (14), (12), (13)(), (15) (11) .
 (11), (8), (22), (2), (5), ()
)(10), (4), 1 (9) (18) .

24 25 (109) 가 8 9 (101)
 (8) 가 (109) (8) (8) (21)
 (4) 가 , 가 가 (2)

10 26 27 26
 10 (110) (1), (2),
 (3), (4), (5), (6), (7) (21, 21)
 (8) 3 가 26 (109) (20) () (2)

27 (110) A-A 27 11
 27 , (20) (17), (16), 2
 (14), (12), (13), (15) (11) .
 (11), (8), (22), (2), (5), ()
 (10), (4), 1 (9) (18) .

26 27 (110) 24 25 (109)
 가 (109) . (8)

11 가 28 29 28
 11 28 (111) (1), (2),
 (3), (4), (5), (6), (7), (8) (21) ()
 28 (111) (19)((2)

29 (111) A-A 29 11
 29 , (20) (17), (16), 2
 (14), (12), (13)(), (15) (11) .
 (11), (8), (22), (2), (5), ()
)(10), (4), 1 (9) (18) .

28 29 (111) 24 25 (109)
 (8) (111) (8)
 (21) (111) (4) 가 (8) 가 (2) 가
 (202) 가 가 가
 , (20)

) 3 (3), (4), (5), (6), (7) (21) (8)
) 36 (115) (20) (2)

37 (107) A-A 37 15
 37 (20) (17), (16), 2
 (14), (12), (13), (15) (11)
 (11), (8), (22), (2), (5), ()
 (10), (4), 1 (9) (18)

36 37 (115) 32 33 (113)
 (4) (4) (8) 가 (19) 가 (115) (8)
 (8) 가 (21) 가 (4)
 (115) (2) 가 (20)
 (20) 가 (2) (4) 가 가

16 38 39 38
 (3), (4), (5), (6), (7) (116) (1), (2),
 (8) 3 38 (116) (20) (21, 21) (2)

39 (116) A-A 39 16
 39 (20) (17), (16), 2
 (14), (12), (13), (15) (11)
 (11), (8), (22), (2), (5), ()
)(10), (4), 1 (9) (18)

38 39 (116) 36 37 (115)
 (116) (21) (116)

17 40 41 40
 (3), (4), (5), (6), (7) (117) (1), (2),
 (8) 3 40 (117) (20) (21, 21) (5)

41 (116) A-A 41 17
 41 (20) (17), (16), 2
 (14), (12), (13), (15) (11)
 (11), (8), (22), (2), (5), ()
 (10), (4), 1 (9) (18)

(8) (21) (2) 2 (23) (21)
 (4)

2 (23) ITO (4) (4) (23) 가 (8) 2
 (8) 가 (23) 가 (4) 가 (8)

가 (101 115) 가

40 41 (117) 38 39 (116) (11)

7) , (2) (4) 가
 , 가 가 (8) 2 (23) (2) (4) 가
 , (117) (2), (4), (8), 2 (23) 가
 , (5) (20) (20)

가 (2) (4) 가
 가 , ,

23) (3), (4), (8) 3 18 42 43 (118) (1), 42
 (5) (8)) 42 (6), (7) (118) (21, 21) 2 ((

43 (118) A-A 43 18
 (20) (17), (16), 2
 (14), (12), (13), (15) (11) (22), (2), (5),
 (() (10), (4), 1 (9) (18) (18)

42 43 (118) 40 41 (117) (118) ,
 (8) (notch) 2 (2) (8) (8)
 (4) 2 (23) 2 (23) (23)
 (118) , (20) (20)

가 (2) (4) 가
 가 , ,

19 44 45 (119) (1), 44
 (3), (4), (5), (6), (7) (21a, 21b, 22c, 22d) 2
 (23) (8) 3 44 (119) (20)

((5))

45 (119) A-A 45 19
 (20) (17), (16), 2
 (14), (12), (13), (15) (11) (22), (2), (5),
 (() (10), (4), 1 (9) (18) (18)

44 45 (119) 40 41 (117)
 (119) , (8) (21a, 21b) (2) (8) 2 2 (23)
 (21c, 21d) (4) (8) 2 (23) (8) 2 가

20 46 47 (120) (1), 46
 (3), (4), (5), (6), (7) (21a, 21b, 22c, 22d) 2
 (23) (8) 3 46 (120) (20)

(19)((5))

47 (120) A-A 47 20
 (20) (17), (16), 2
 (14), (12), (13), (15) (11) (22), (2), (5),
 (11), (8), 2 (23), (18)

() (10), (4), 1 (9) (18) .

46 47 (120) 42 43 (118) .
 (120) , (8) (21a, 21b) (2) 2 (23)
 (21c, 21d) (4) (8) 2 (23) (23)
 가

, 21 48 49 48
 21 (121) (1), (2),
 (3), (4), (5), (6), (7) (21, 21) 2
 (23) (8) 3 48 (121) (20) (1)
 9) (2) 15 가)

49 (121) A-A 49 21
 49 , (20) (17), (16), 2
 (14), (12), (13), (15) (11)
 (11), (8), 2 (23), (22), (2), (5),
 () (10), (4), 1 (9) (18)

(8) (21) (2) 2 (23) (21)
 (4)

(8) (2) (8) (2)
 가 2 (23) (4) 가 2
 (23) (4) 가

48 49 (121) 40 41 (117) 2 ()
 23) 가 가 (8) , 가 (121) (102)

, 22 50 51 50
 22 (122) (1), (2),
 (3), (4), (5), (6), (7) (21a, 21b, 22c, 22d) 2
 (23) (8) 3 50 (122) (20)
 (19) (2) 15 가)

51 (122) A-A 51 22
 51 , (20) (17), (16), 2
 (14), (12), (13), (15) (11)
 (11), (8), 2 (23), (22), (2), (5),
 () (10), (4), 1 (9) (18)

(8) (21a, 21b) (2) 2 (23) (21c, 21d)
 (4) (122) (8) 2 (23)

, 23 가 52 53 52
 23 (123) (1), (2), (3),
 (4), (5), (6), (7) (21a, 21b, 22c, 22d) 2 (2)
 3) (8) 3 52 (122) (20) (19)
 (2) 15 가)

53 (123) A-A 53 23
 53 , (20) (17), (16), 2
 (14), (12), (13), (15) (11)
 (11), (8), (24), 2 (23), (22), (2),
 (5), () (10), (4), 1 (9) (18)

3) (123) 2 (23) 50 51 (122) 2 (2)

(123) , 2 (23) (22) (4)

(23) (8) (22) 2 (24) 2

(23) (8)

54 (2), (4) 2 54 52 53 54 (23) (4) Wu 2 (23)

Wt (4) 2 (23) 가 가 (8)

(2) (8) 2 (23) (4) (Wt Wu, , Wt Wu

(2) + 2(μm)

55 a b (21) 2 55 b (21) B-B

(23) (22) (23) () (10) 2 (4)

(21) (2) (8)

56 a l 56 a (Cr) 55 b B-

B 1 (9)

56 b (22) 56 c (SiNx) (: SiO₂/S

iNx)(10) () (10) (a-Si, n + a-Si)

56 d a-Si) 56 e P-CVD 가 56 b e (3) , SiO₂ , (a-Si, n + , 3

56 f (3) 가 56 h 56 g

가 56 f 56 h

(22) (SiNx) 56 j (22) () CVD

56 i j

ITO 56 k ITO ITO ITO 56 i , ITO

ITO , ITO , ITO , ITO

가 56 k i , ITO

ITO , ITO

가 , , 가

(8) 2 (23) (2) 가 (4)

가

가
,
' 가 .

가

(57)

1.

,
,
,
가
,
가 가 ,
가

2.

,
,
,
가
,
1 ,
1 , 2
1 2 .

3.

,
,
,
가
,
1 ,
1 , 2
1 1 , 2 1 2

4.

가

2 5.

3 6.

4 7.

1 8. 5

1 9. 5

9 10.

(notch)

1 11. 7

8 12.

,
,

9 13.

,
,

10 14.

,
,

11 15.

,
,

12 16.

,
,

13 17.

,
,

14 18.

,
,

1 19. 7

,
,

IT0

20.

ITO

1

종래기술

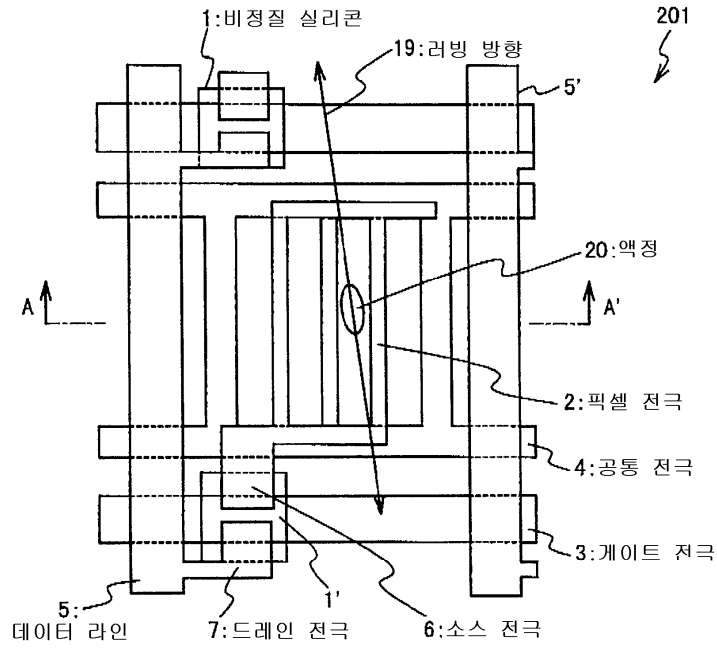

2

종래기술

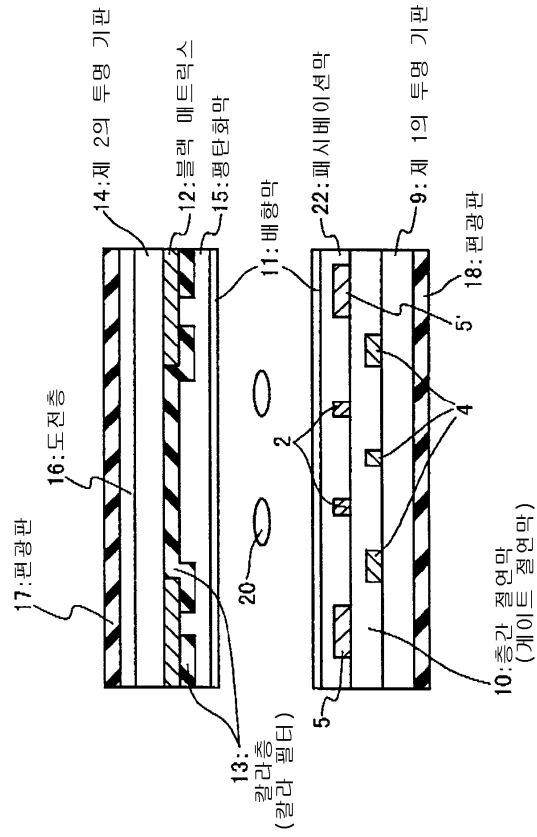

3

종래기술

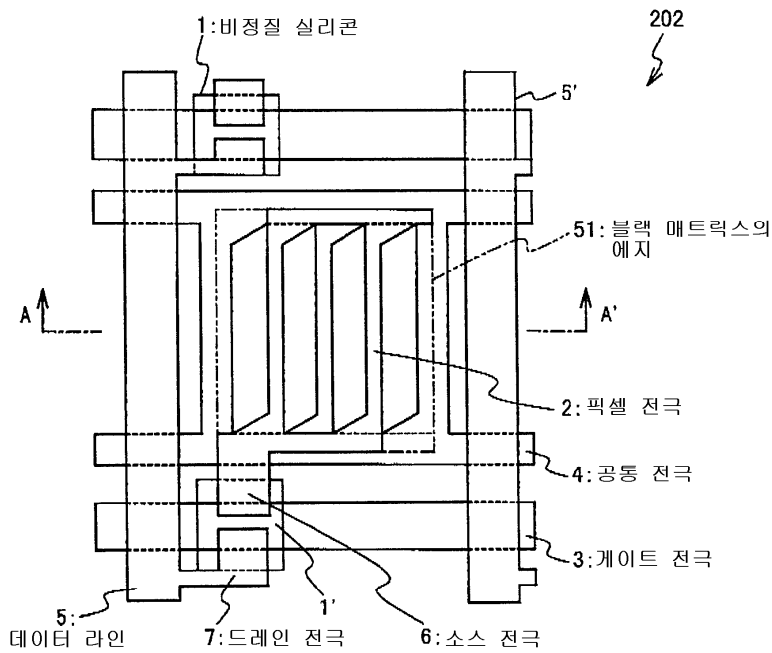

중래기술

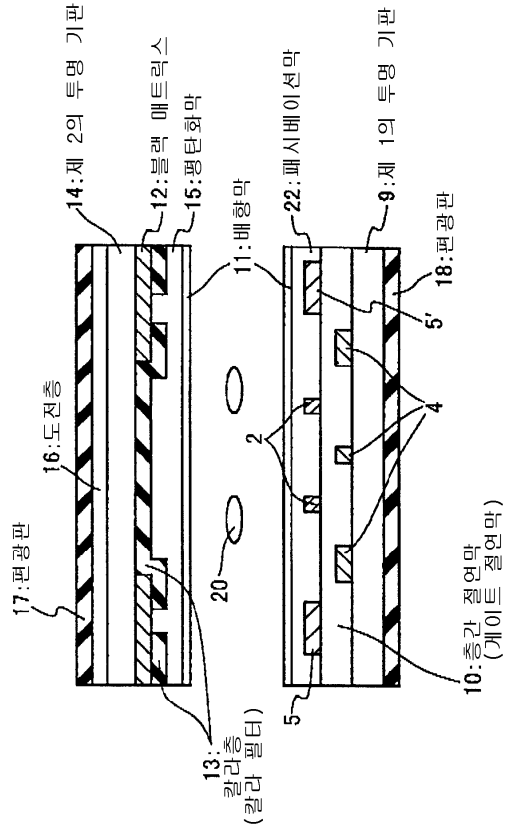

중래기술

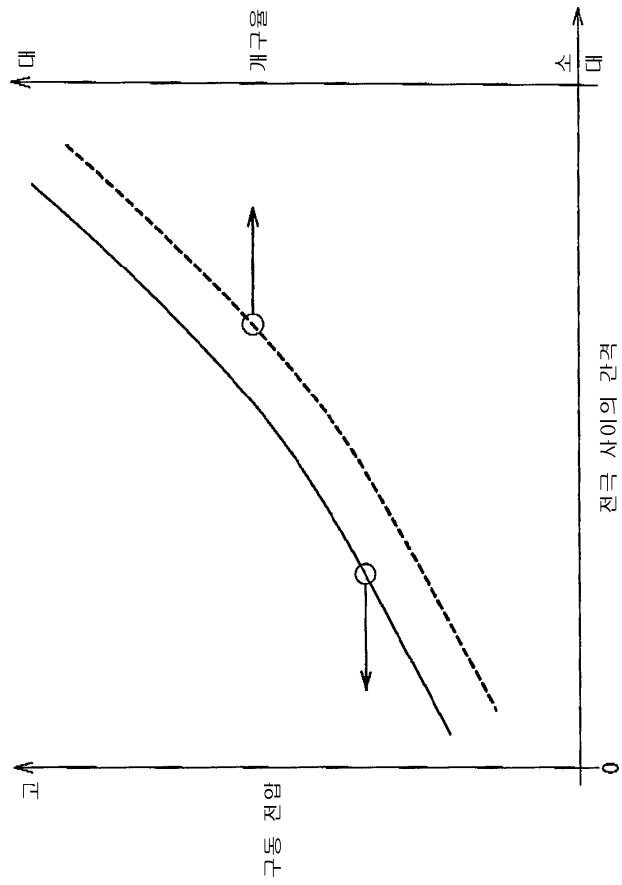

6

종래기술

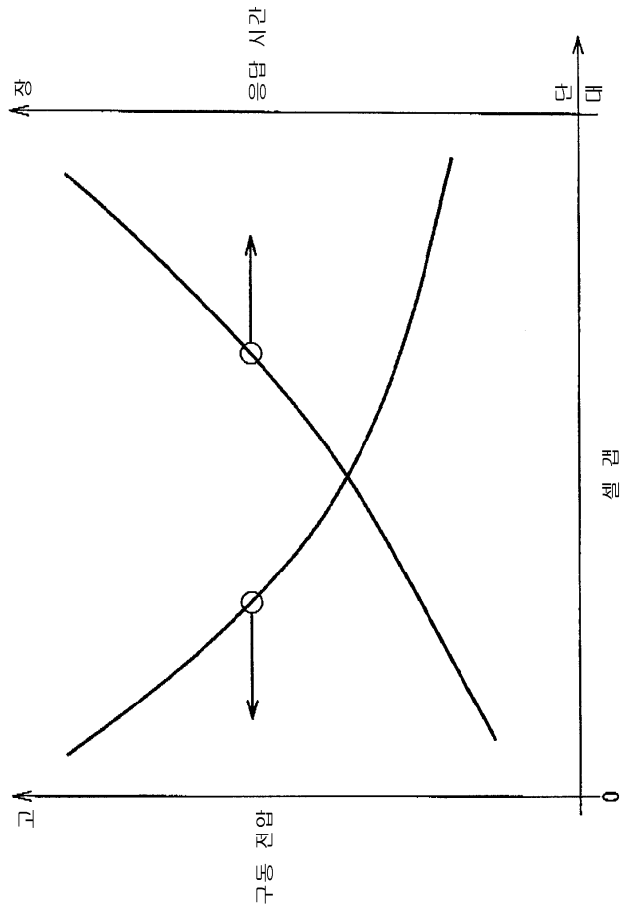

7

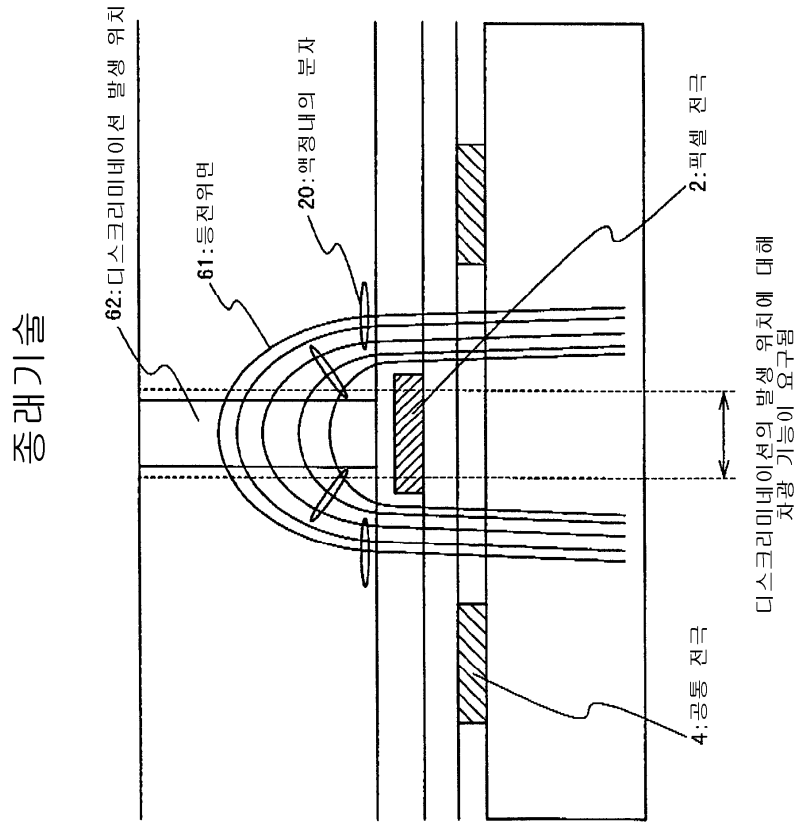

8

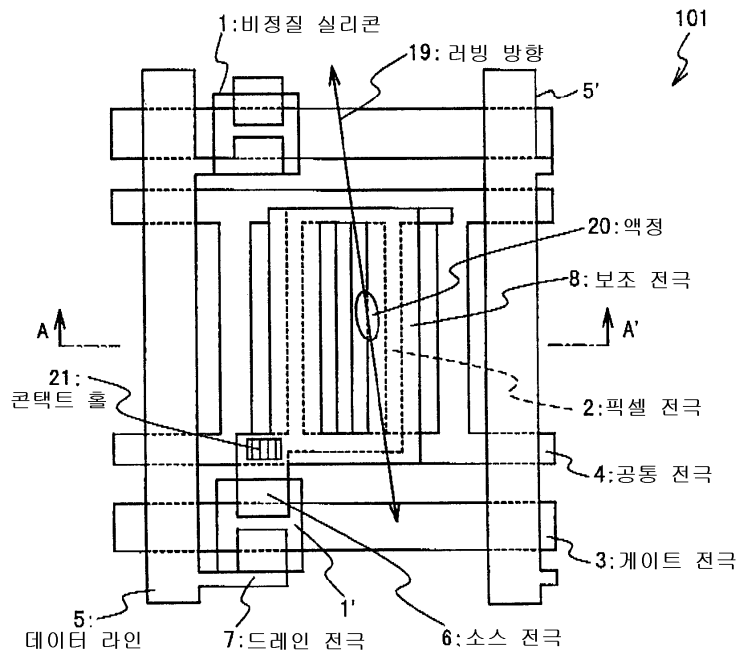

9

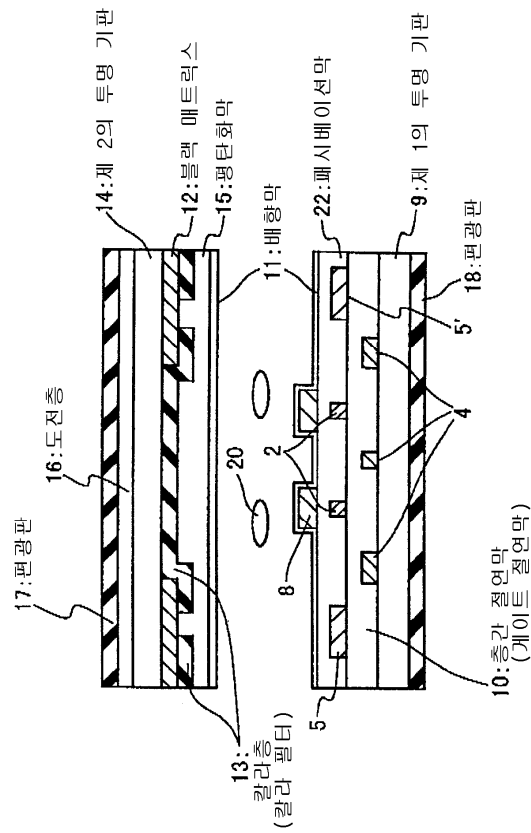

10

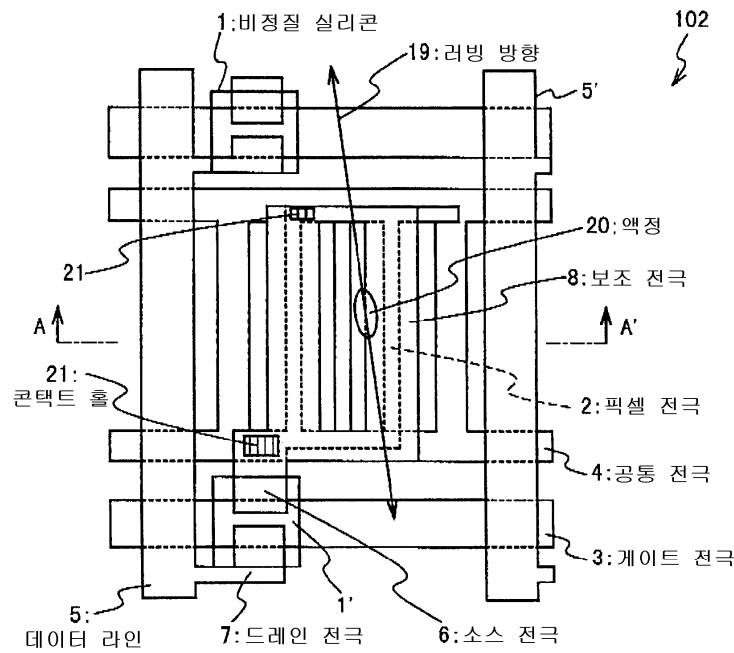

11

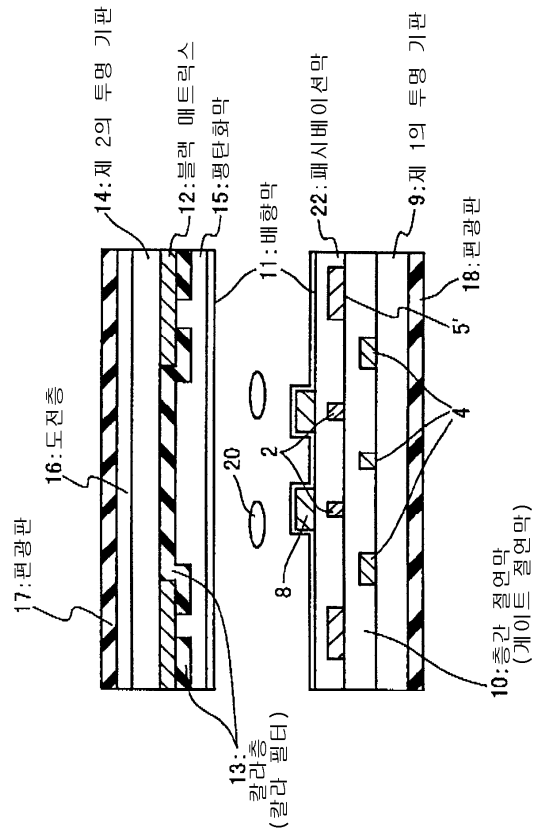

12

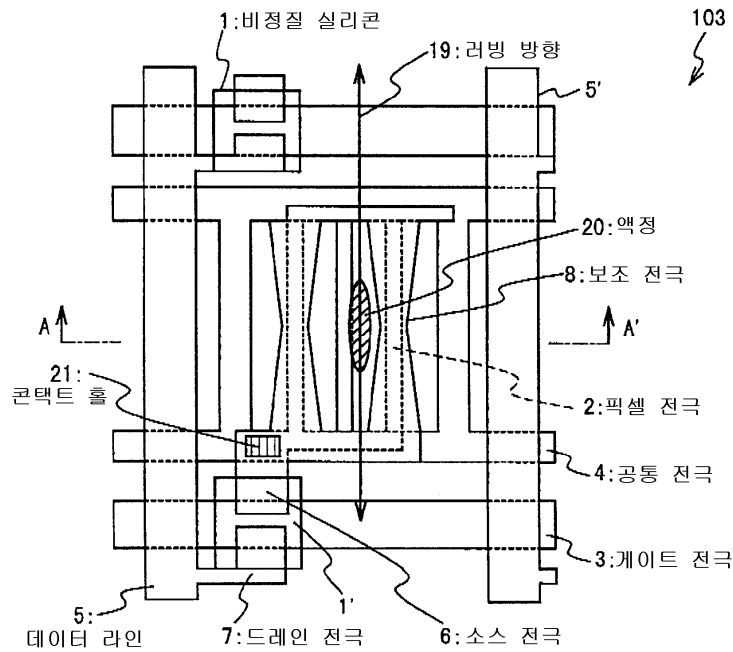

13

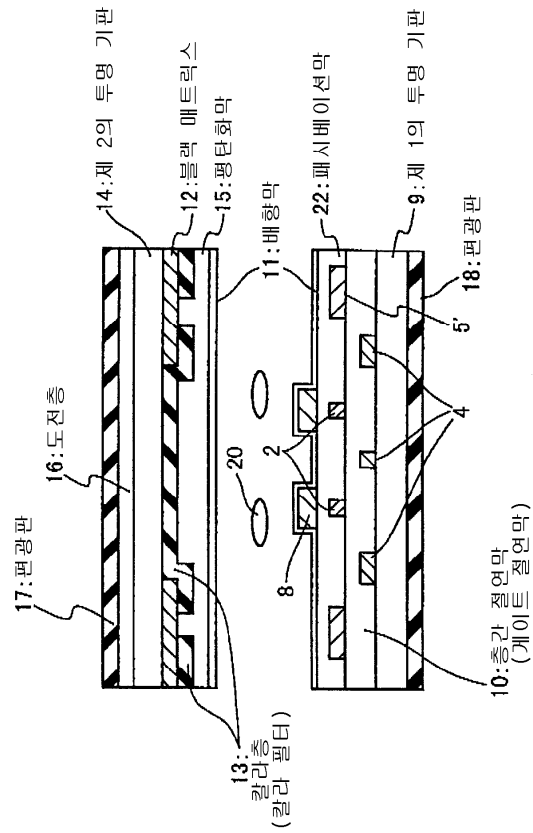

14

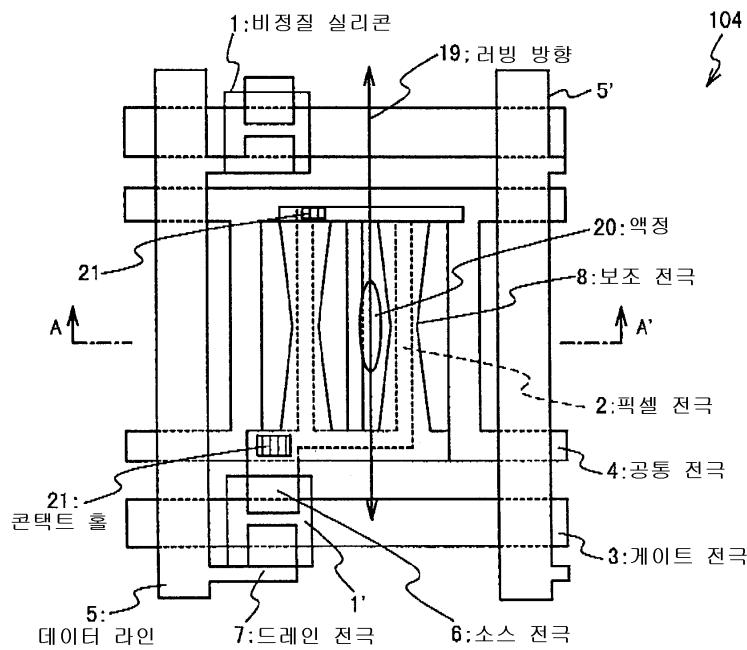

15

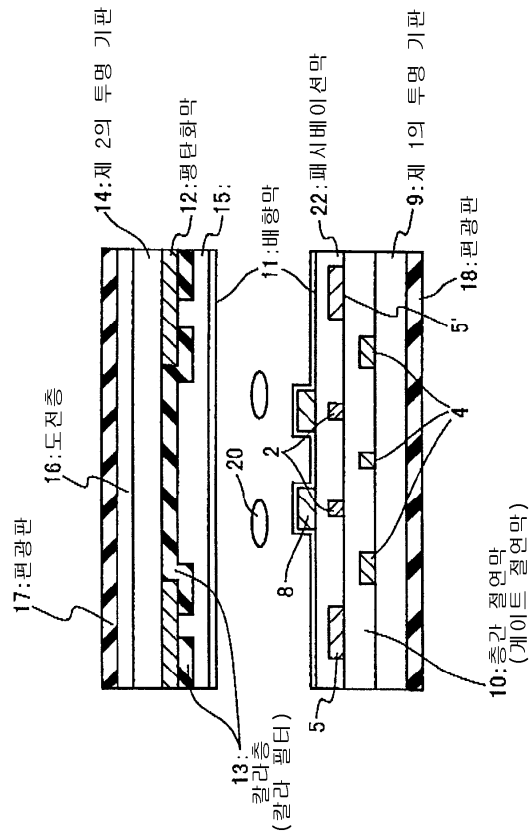

16

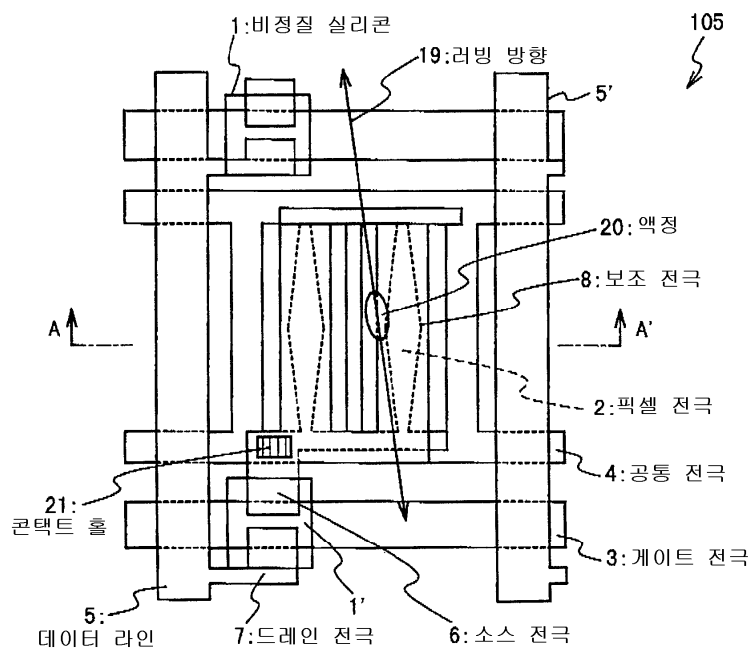

17

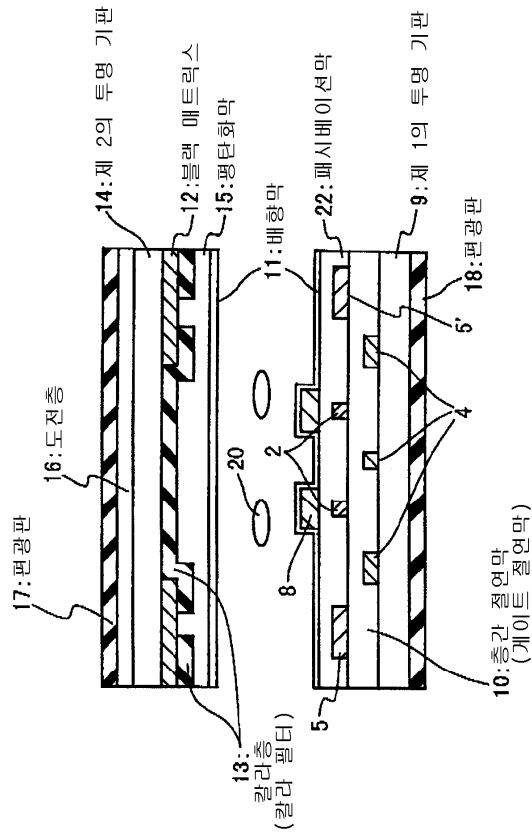

18

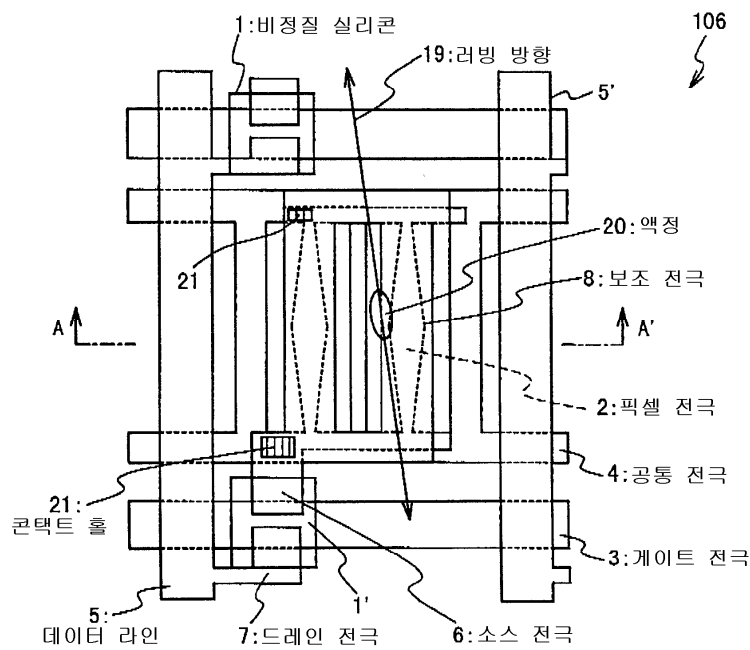

19

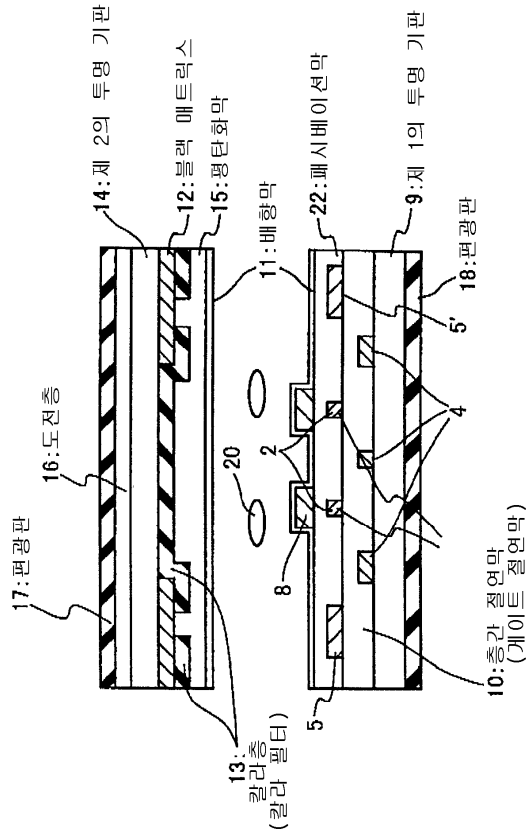

20

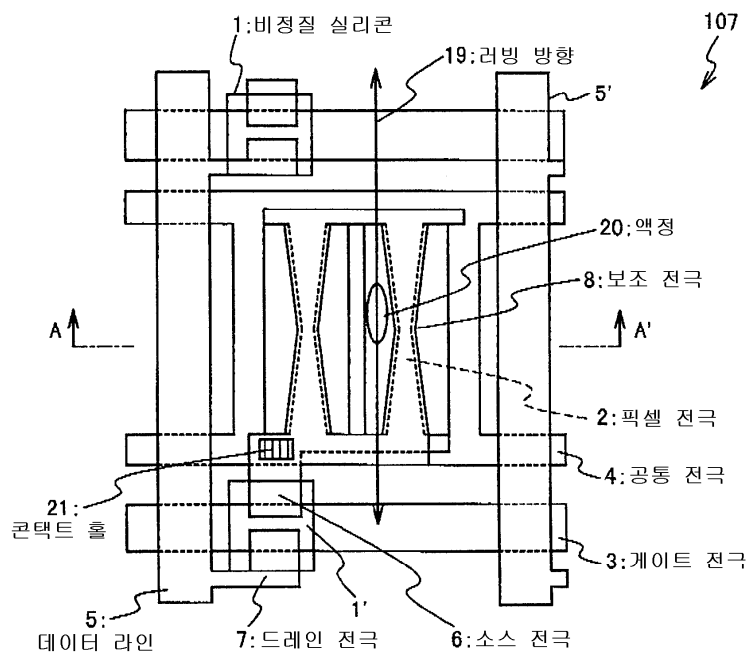

21

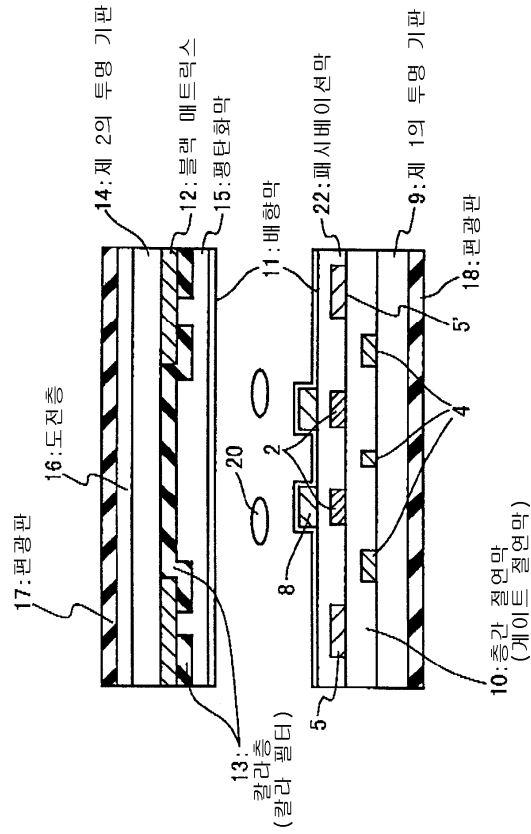

22

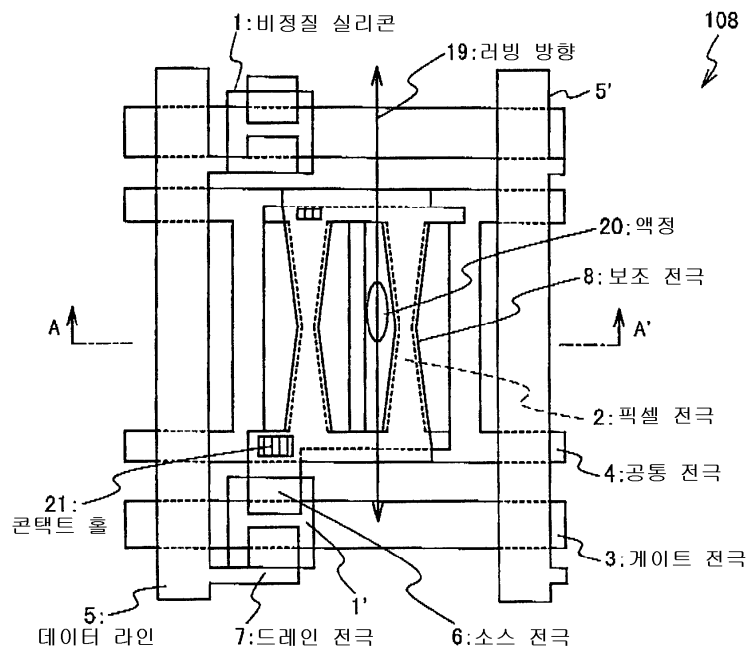

23

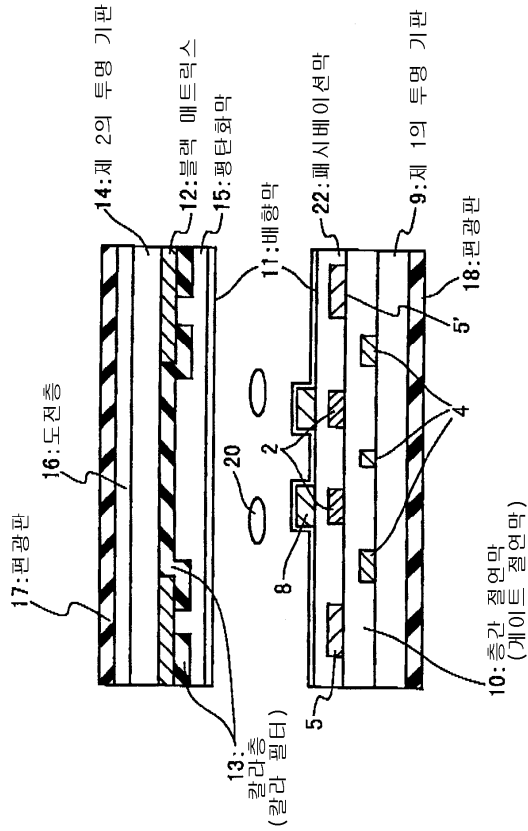

24

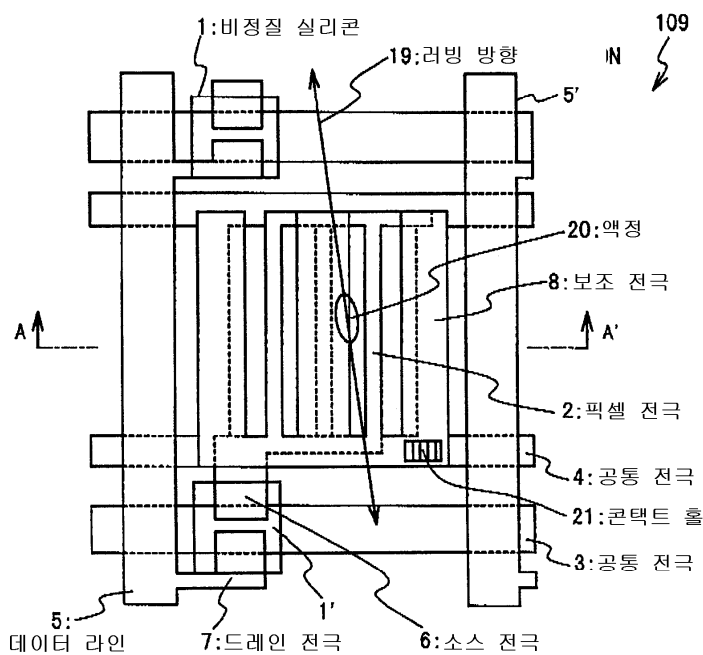

25

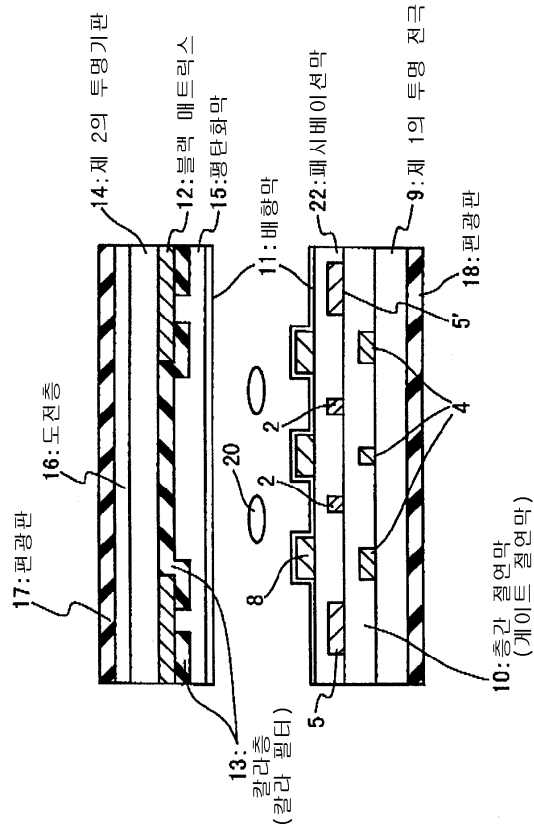

26

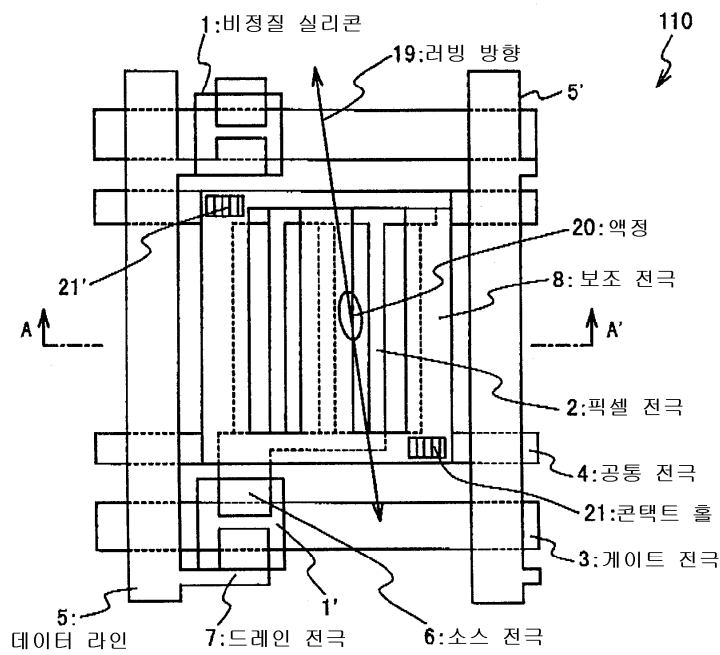

27

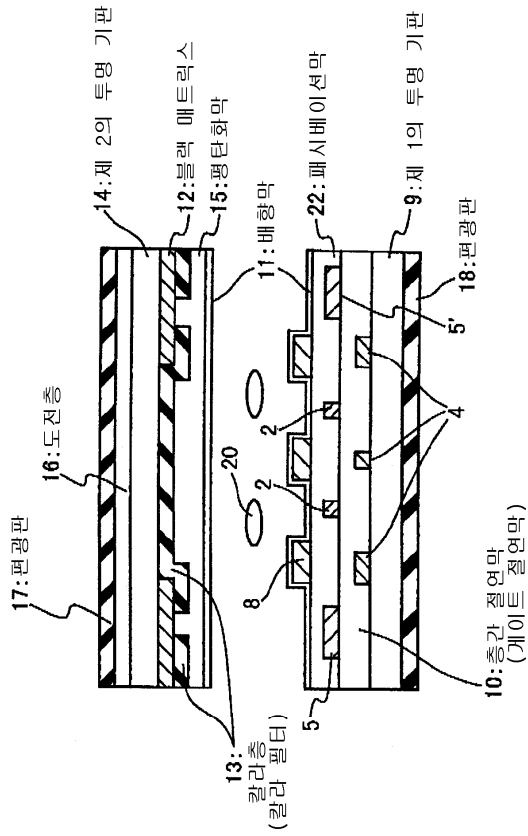

28

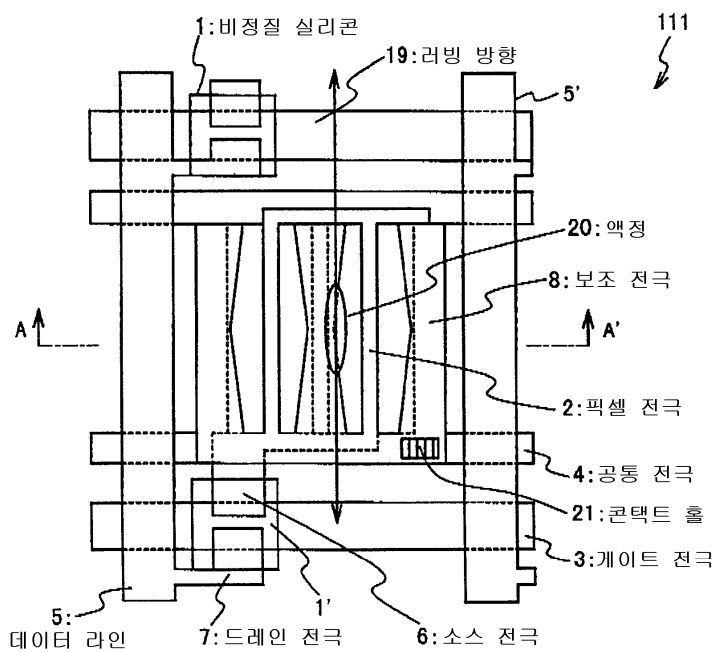

29

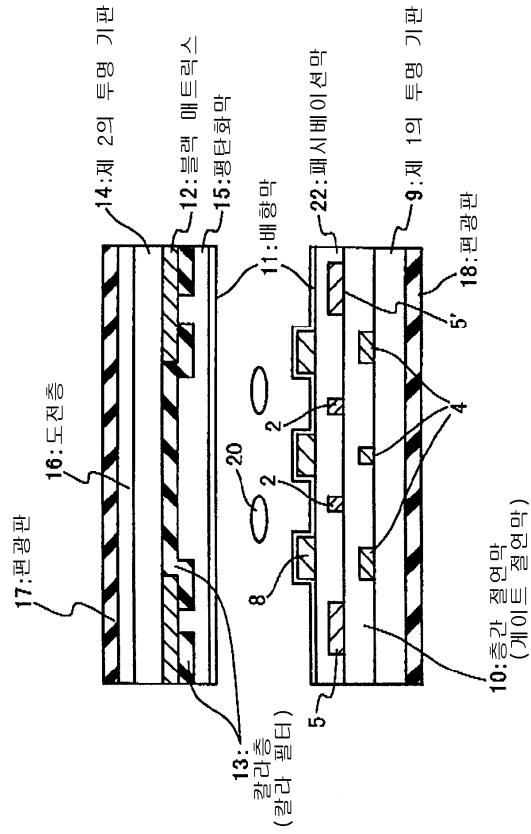

30

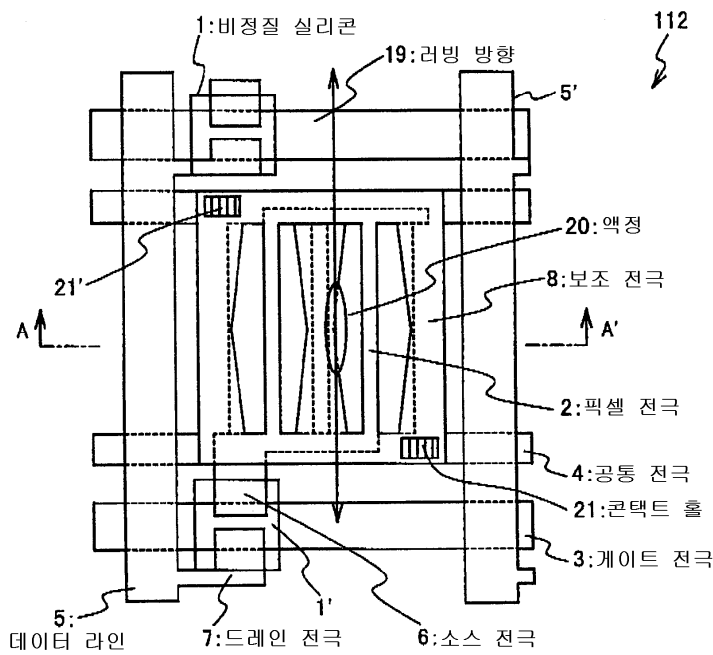

31

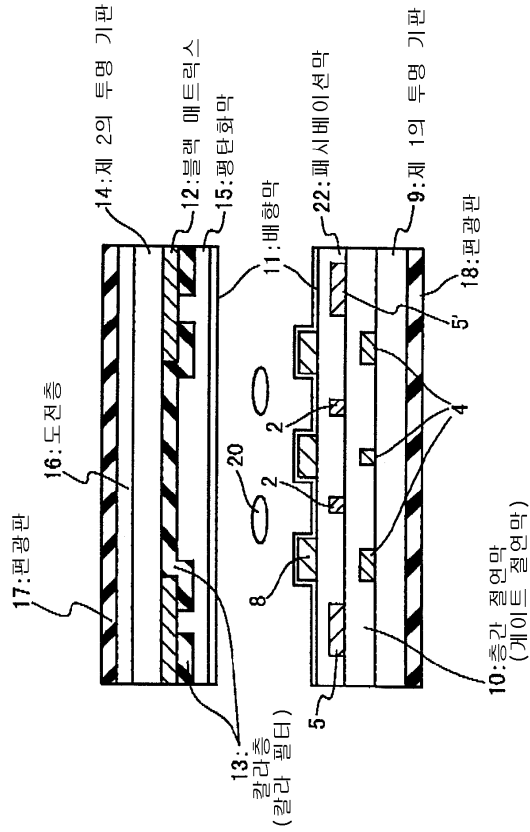

32

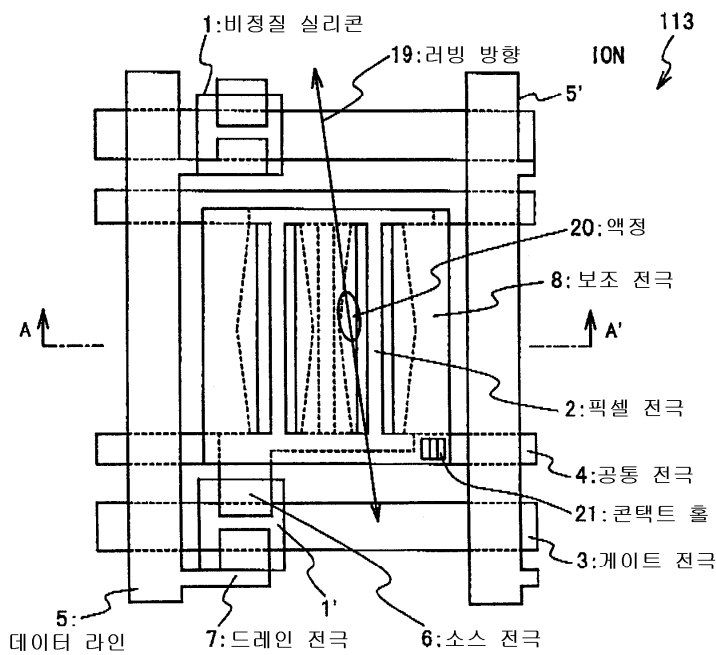

33

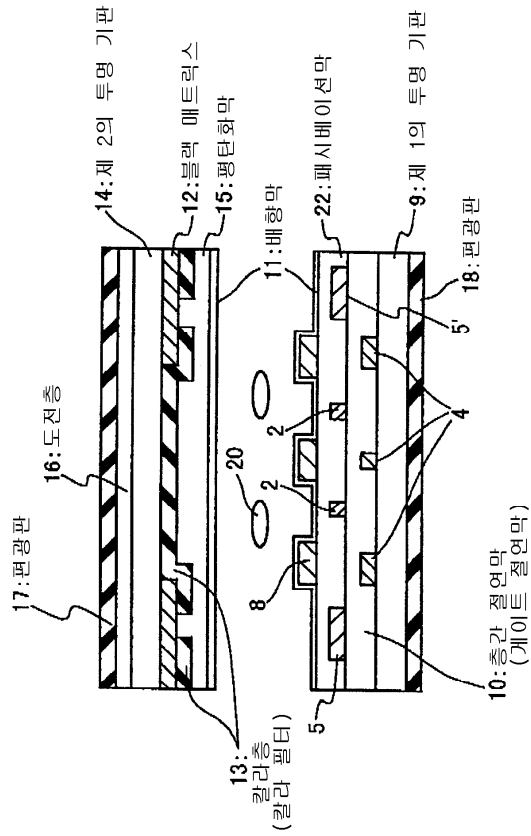

34

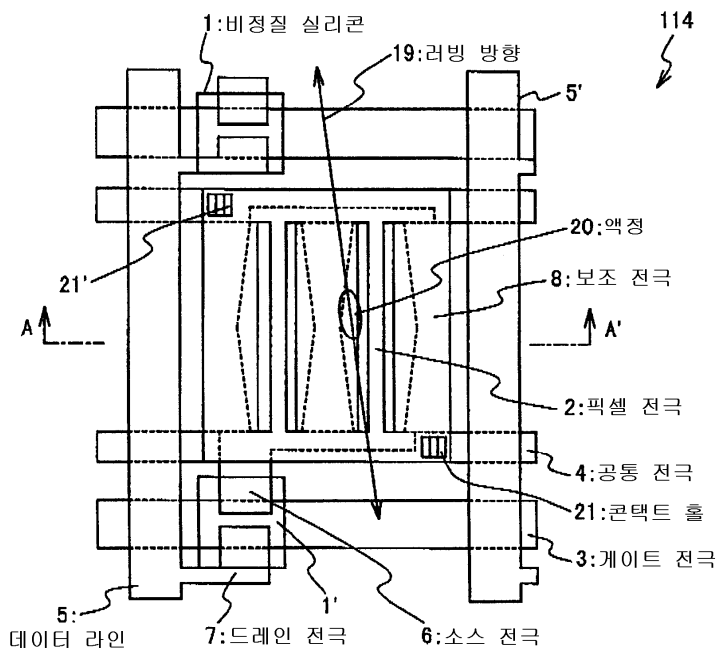

35

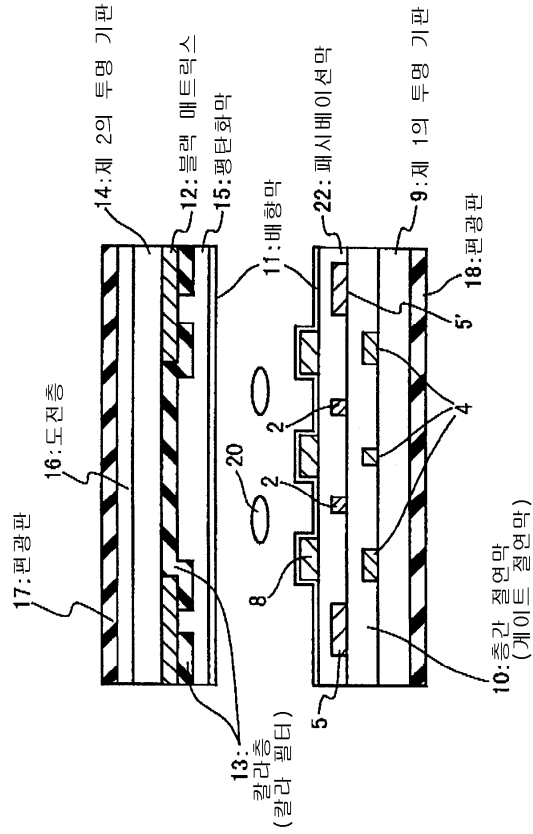

36

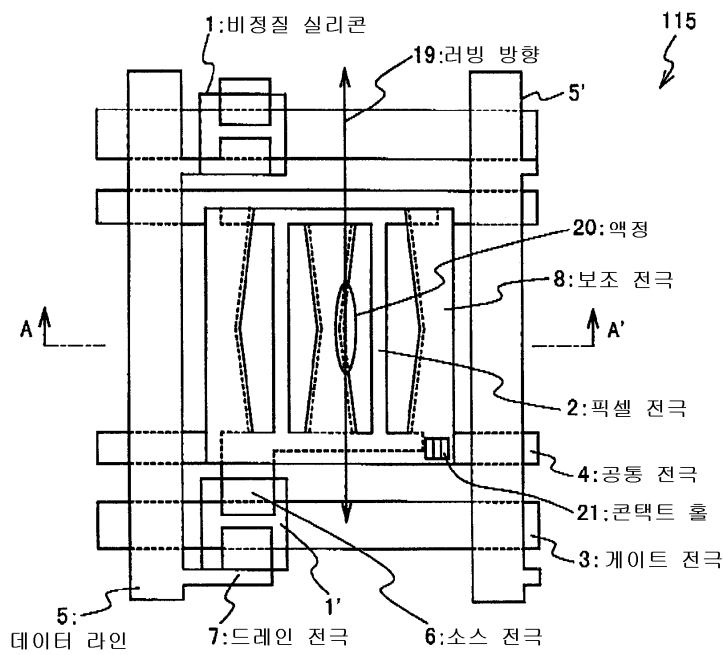

37

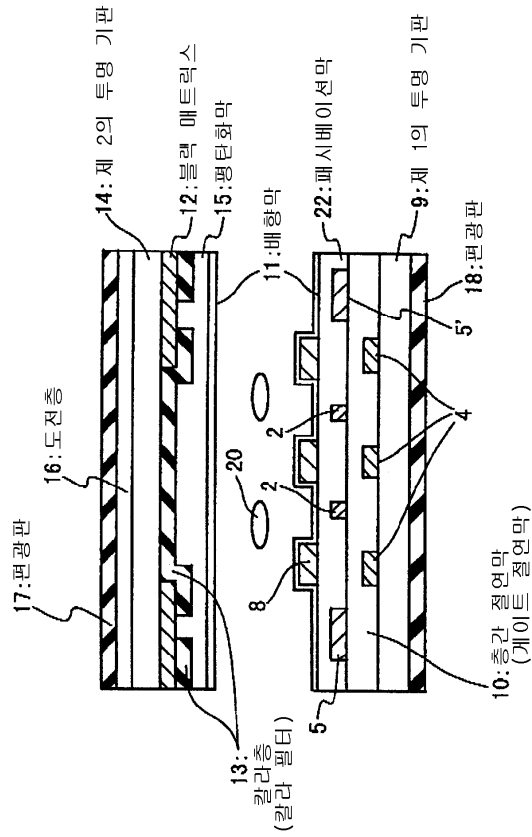

38

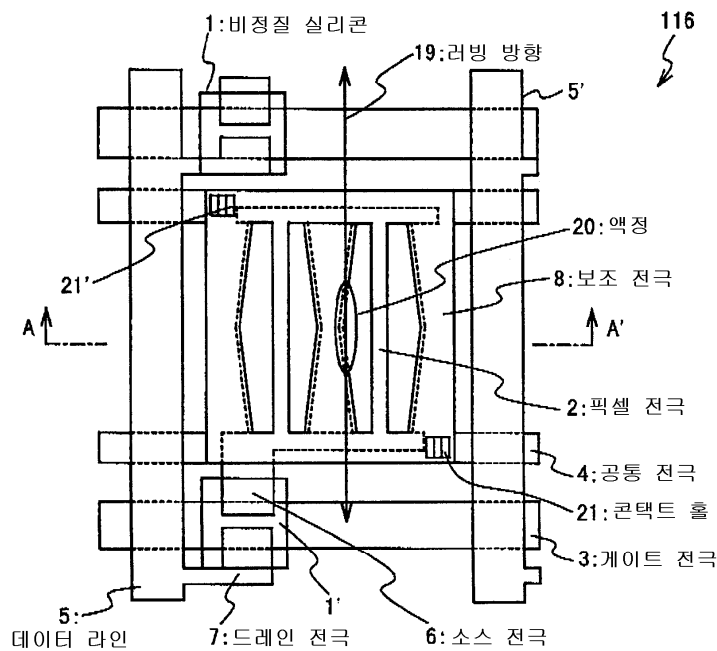

39

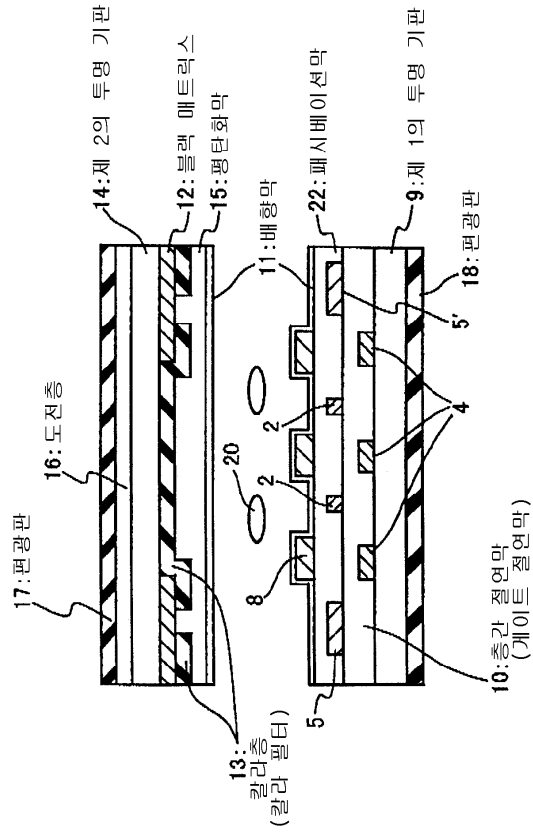

40

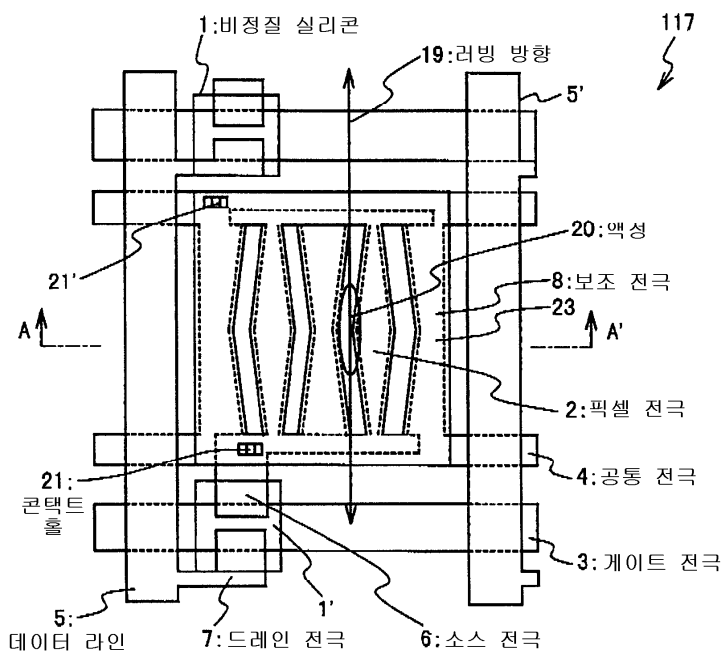

41

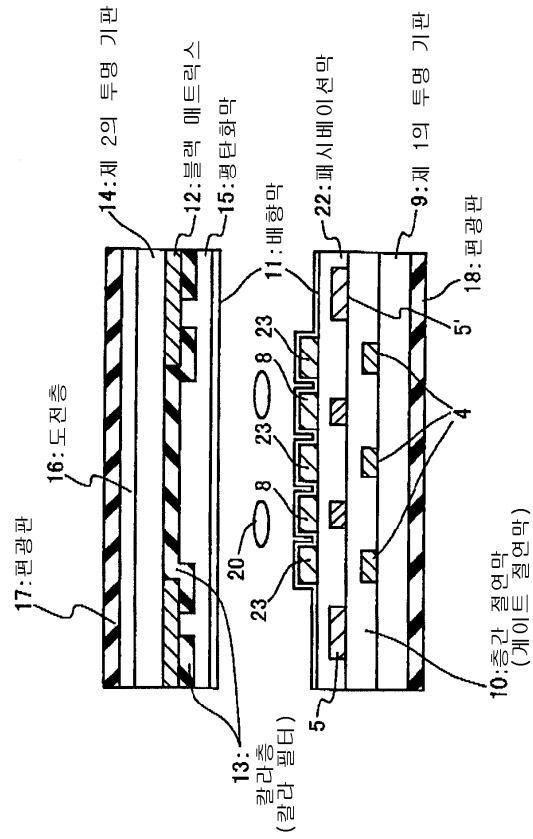

42

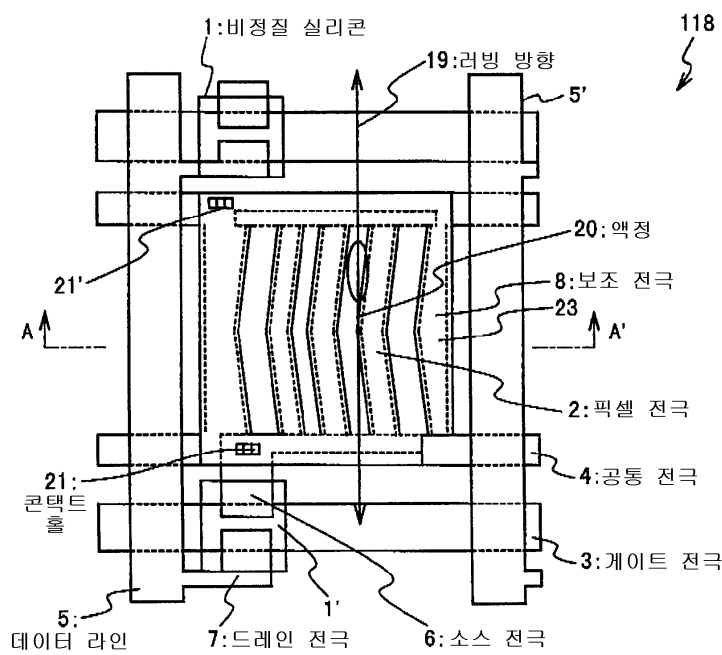

45

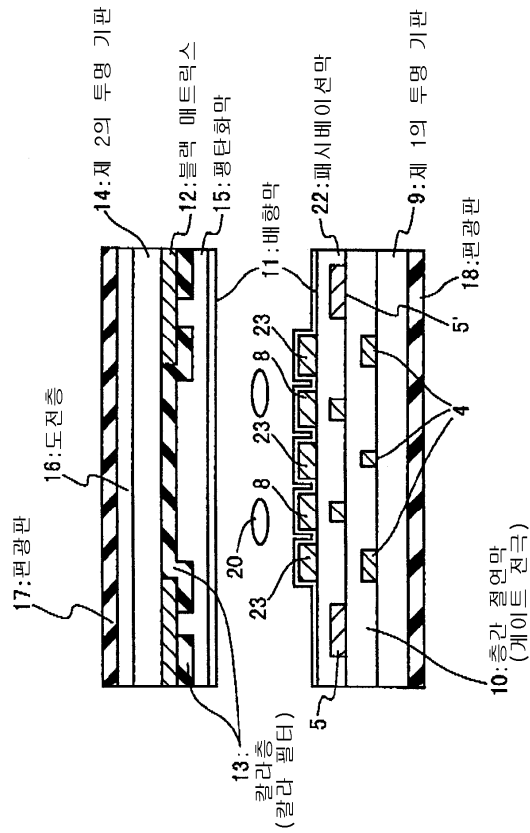

46

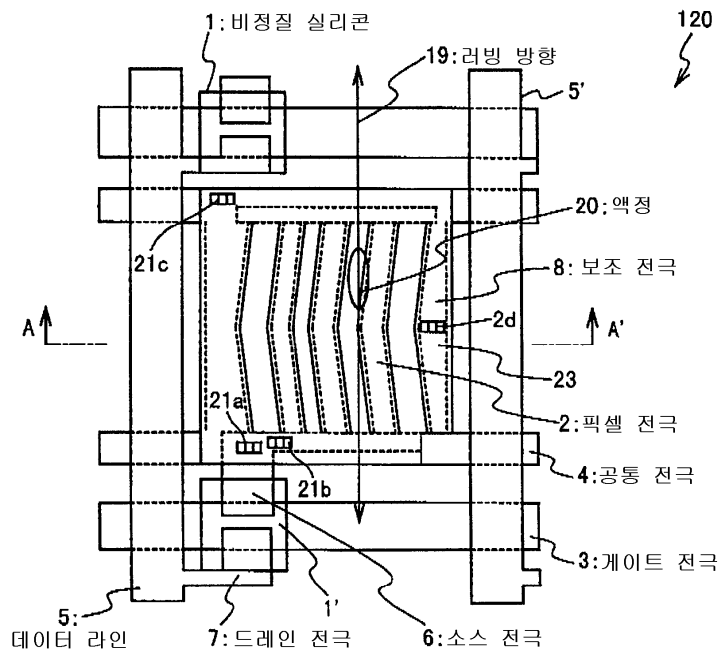

47

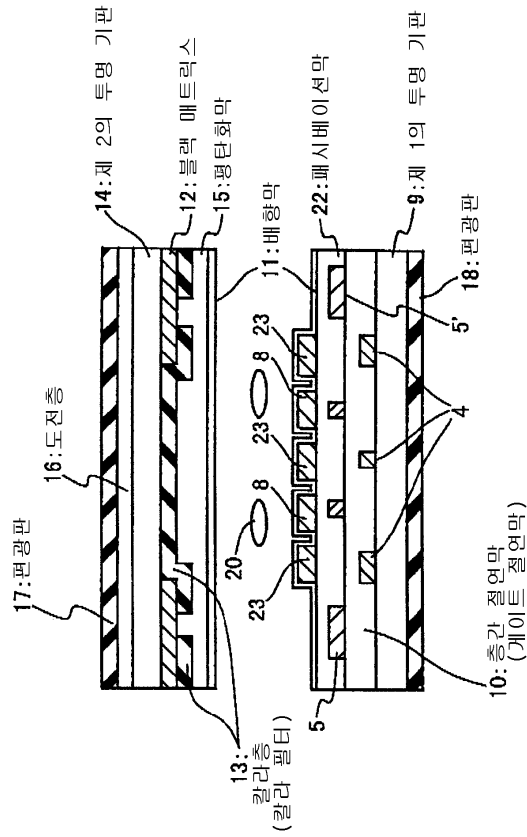

48

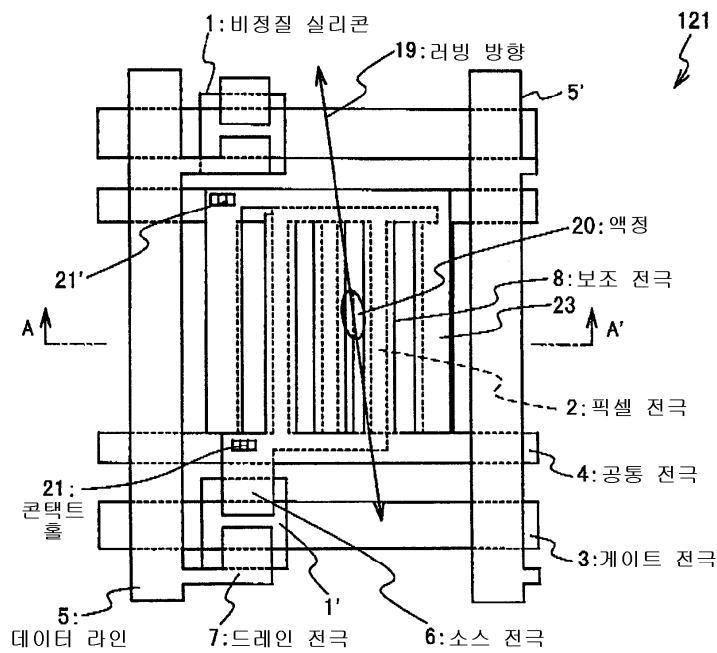

49

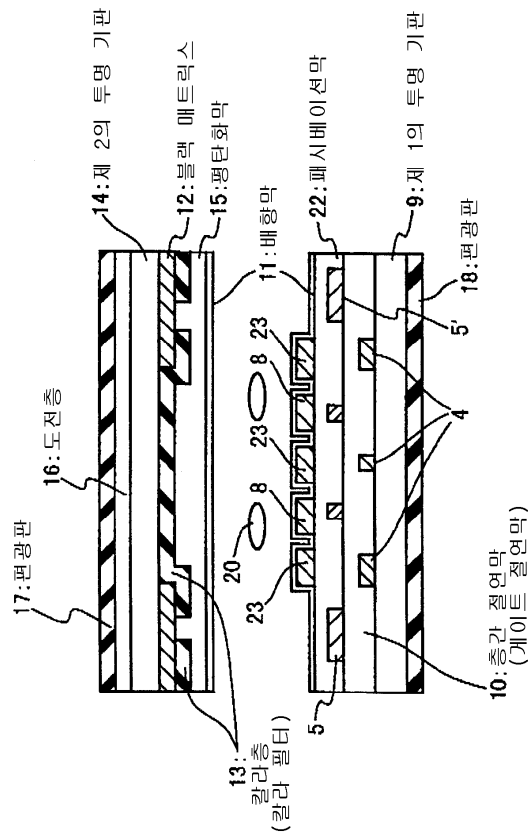

50

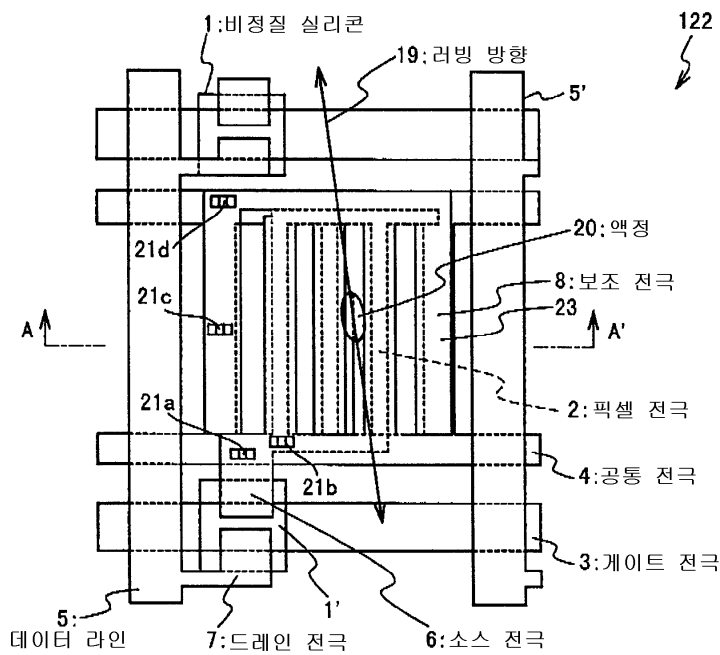

51

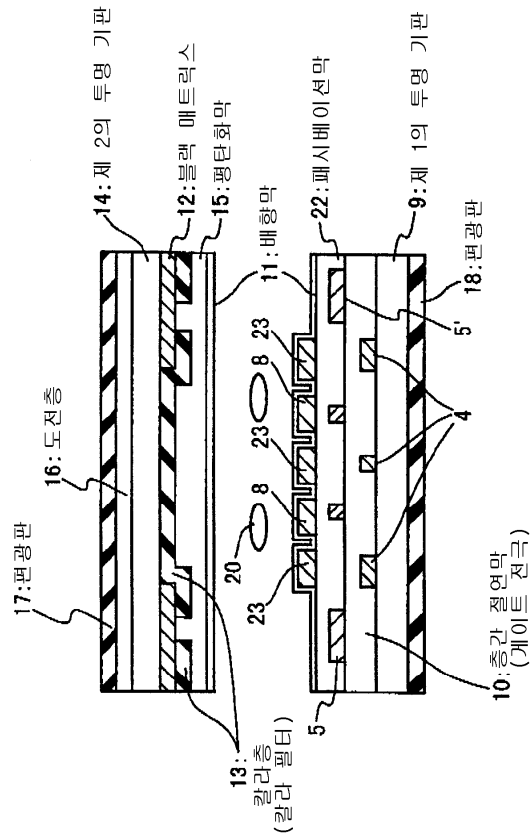

52

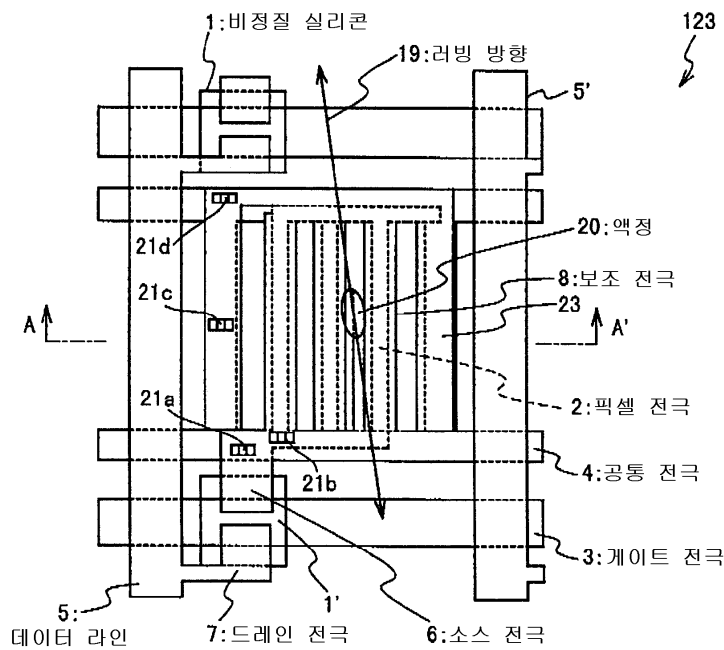

53

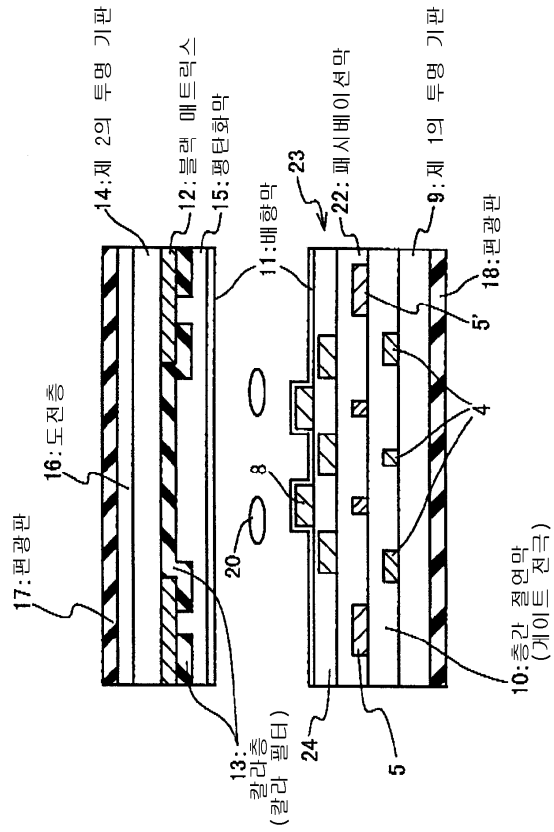

54

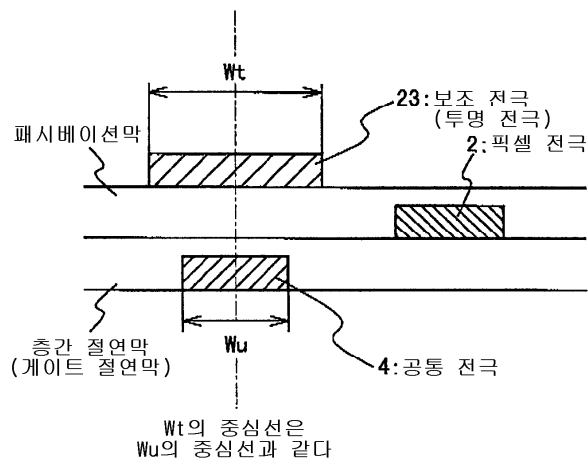

55

a

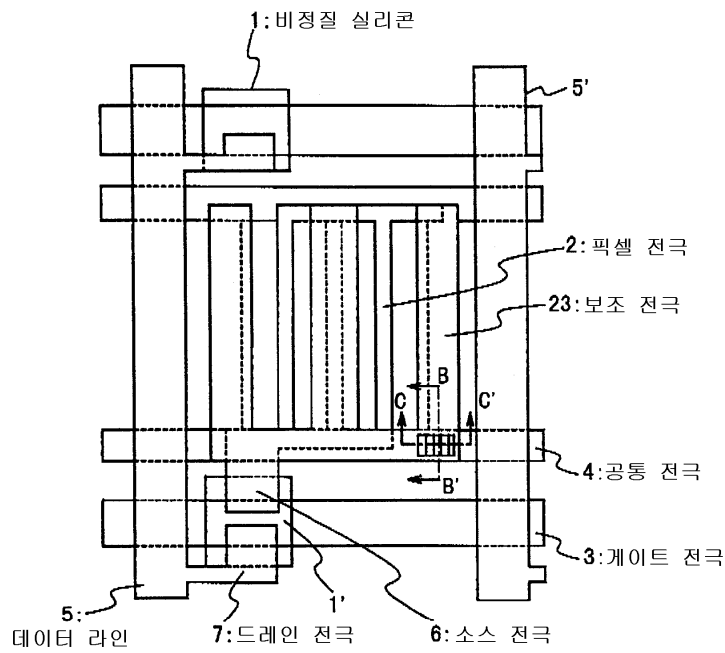

b

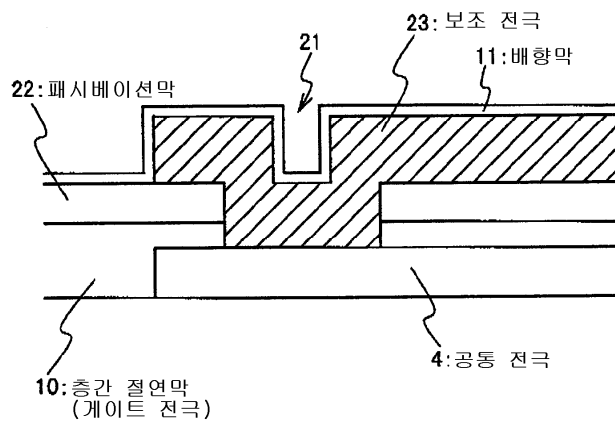

56

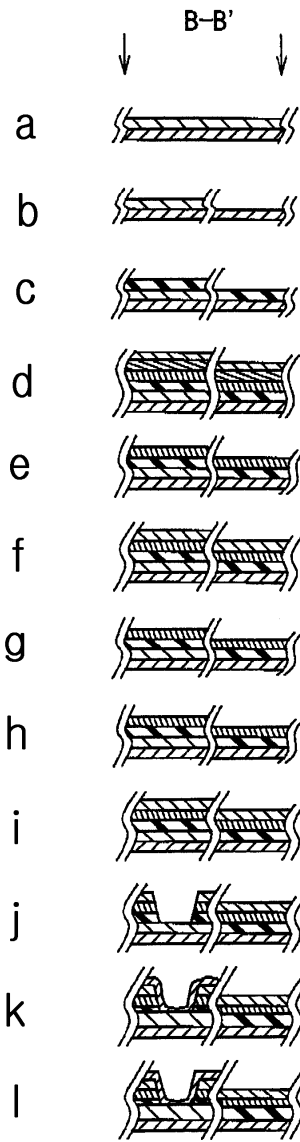

专利名称(译)	有源矩阵型液晶显示器		
公开(公告)号	KR200353899Y1	公开(公告)日	2004-06-22
申请号	KR2020040007429	申请日	2004-03-18
[标]申请(专利权)人(译)	NEC液晶技术株式会社		
申请(专利权)人(译)	日元号技术可否让这个夏		
当前申请(专利权)人(译)	日元号技术可否让这个夏		
[标]发明人	MATSUMOTO KIMIKAZU		
发明人	MATSUMOTO,KIMIKAZU		
IPC分类号	G02F1/1343 G09F9/30 G02F1/136		
CPC分类号	G02F1/134363		
优先权	2000147578 2000-05-19 JP		
外部链接	Espacenet		

摘要(译)

有源矩阵液晶显示器包括一对基板，液晶层和像素电极，公共电极和透明辅助电极。液晶层设置在一对基板之间。像素电极和公共电极设置在一对基板中的一个或多个上部。提供给在梳子中安装像素电极和透明电极的间隙和几乎所称的电场，在液晶层中围绕一对基板产生平行。透明辅助电极穿过公共电极上部的绝缘层。诸如公共电极的电压的电压施加在透明辅助电极处，并且施加在液晶层处的电场增加。液晶显示器，公共电极，辅助电极，像素电极，矩阵，晶体管。

