

(19)  
(12)

(KR)  
(A)

(51) 。 Int. Cl. <sup>7</sup>  
G02F 1/1335

(11)  
(43)

2002 - 0058710  
2002 07 12

---

(21) 10 - 2000 - 0086840  
(22) 2000 12 30

---

(71) .  
,  
20  
(72) 4 622 10 509  
831 - 1 609

(74)  
:

---

(54)

---

8

1

2

3

4

5 TN

6 5b TN

7

8 7

9 7

< >

1 : 2 :

3 : 4, 14, 24:

5, 15, 25 : 6 : CCD

7, 17 : 8 :

9 : 10 :

11 : 13 :

30 : 31,41,51,61 :

32, 42 : 33, 43, 53 :

35, 45 : 37,47,57,67 :

or : " TFT" (Active Matrix) (Thin Film Transist  
 가 가 , (Personal Computer) (Note Book Computer) ,

TFT가 (Seal)  
 (Tape Carrier Package :  
 TCP)  
 (Integrated Circuit : 'IC' )

(short) , ( ) , ( ) ,

1 (9) (on) ,  
 (storage capacitor) , (9) (off) (9)  
 (on) (7) (Thin Film Transistor  
 " TFT" )(1)

2 TFT - LCD 가 TFT - LCD  
 TFT(1) (7) (5) 가 TFT  
 가 (5) (7)가 (13) 가 가 TFT  
 , (7) (32) (3) 가가 (5)  
 , 0 가 , (5) TFT  
 가

TFT 가  
 (11) 3 (17)  
 (repair)  
 가

4 (42) , 4 가  
 (array) (10) 10~20 $\mu$ m (15)  
 1 가 , 가 90° nd  
 ( , p ) 2 ( , s )  
 가 (15) (15) (15)  
 ( , s ) (8) (15) (2) 2  
 (4)

CCD(Charge Coupled Device) (15) (42) (15)  
 (2) CCD(6) . CCD(6)

5 6 , (14) (31) ,  
 (25) , (25) (33) , , 가 가 (35) , 90° 가  
 (41) (43) , (31)

5a , 가 (14) 1 ( ,s ) (31)  
 (33) 가 1 (33) (25) (25) , ,  
 가 (25) 90° 2 ( , p )  
 (R), (G), (B) (35)  
 가 (41) (43) 2 (43)

5b , 가 (14)  
 (33) (30) 1 ( S ) (31), (33)  
 (25) (25) 가 (35) (R),  
 (G), (B) (35) (43) (31) 가 (41) (43)

TN - mode LCD가 ,

7 8  
 7 ,  
 (45), (53), (63) (61) (30) (51) , (R), (G), (B)  
 (25)

8 9 , (24) 가 가  
1 (51) (30) (51) (30)

가 가 가

가 가 가 가 가  
가

(57)

1.

2.

1 ,

3.

2 ,

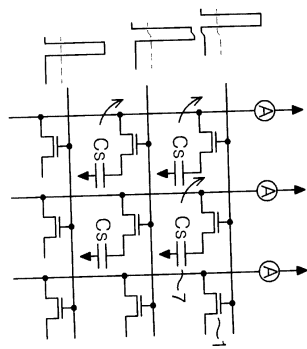
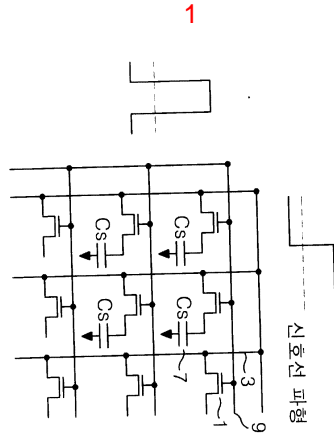

2

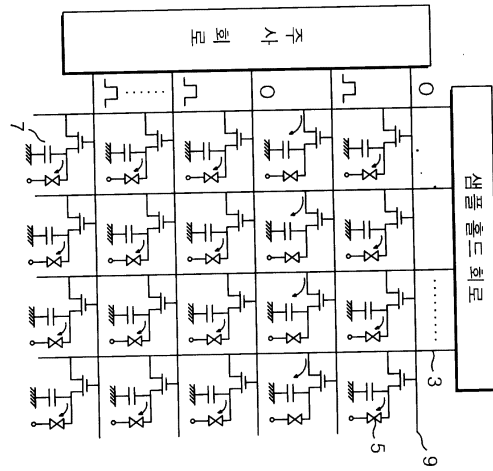

3a

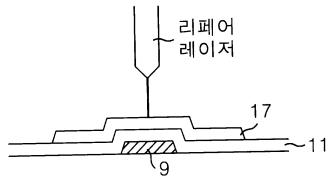

3b

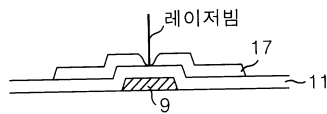

3c

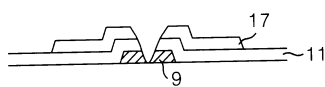

4

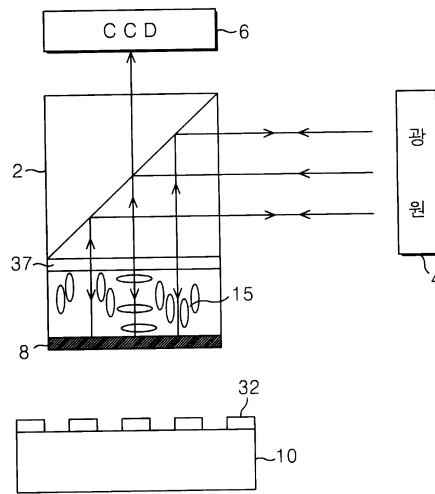

5a

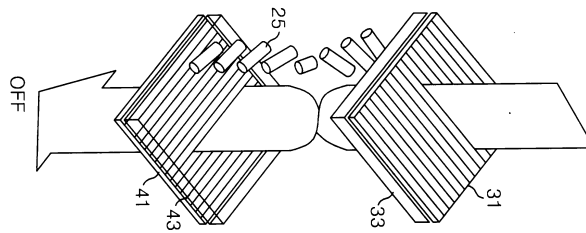

5b

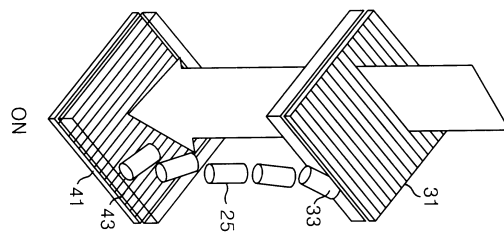

6

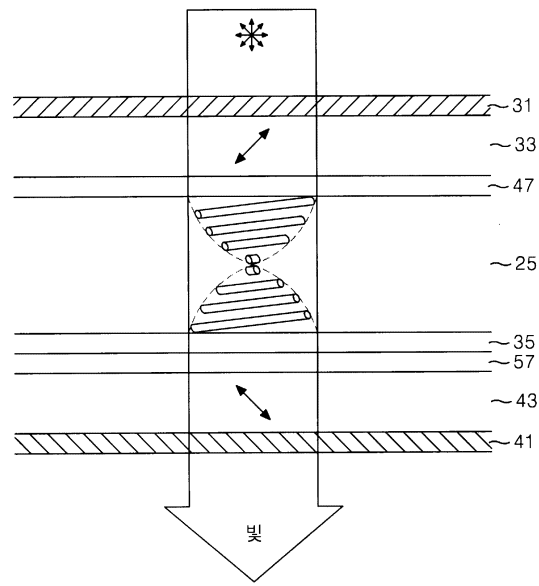

7

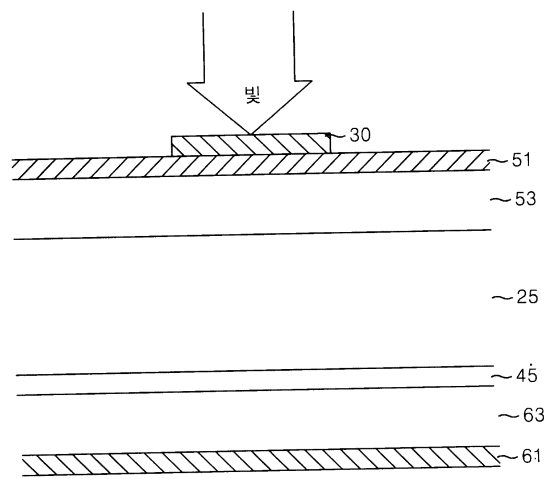

8

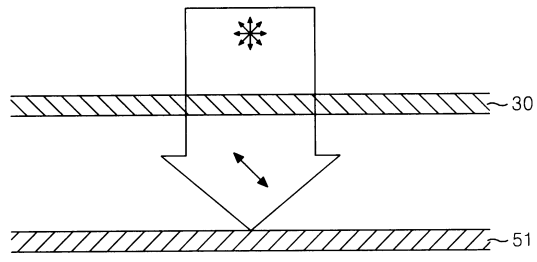

9

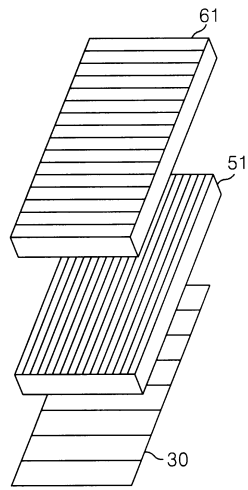

专利名称(译)	液晶显示器		
公开(公告)号	<a href="#">KR1020020058710A</a>	公开(公告)日	2002-07-12
申请号	KR1020000086840	申请日	2000-12-30
[标]申请(专利权)人(译)	乐金显示有限公司		
申请(专利权)人(译)	LG显示器有限公司		
当前申请(专利权)人(译)	LG显示器有限公司		
[标]发明人	PARK SEOUNG JIN 박성진 LEE HYUNG SUK 이형석		
发明人	박성진 이형석		
IPC分类号	G02F1/1335		
其他公开文献	KR100807791B1		
外部链接	<a href="#">Espacenet</a>		

摘要(译)

液晶显示装置技术领域本发明涉及一种液晶显示装置，其中通过使用用于修复的偏振片去除亮点。本发明涉及一种用于修复的偏振板，其与缺陷像素的位置相对应地附接到上板和下板中的至少一个以点燃缺陷像素，和。根据本发明，通过在与下偏振片的方向不同的方向上形成用于修复的偏振片的吸收轴，可以去除亮点以使像素变暗。 8

