



US 20120236228A1

(19) **United States**

(12) **Patent Application Publication**
Tang

(10) **Pub. No.: US 2012/0236228 A1**

(43) **Pub. Date: Sep. 20, 2012**

(54) **BACK LIGHT MODULE AND LIQUID CRYSTAL DISPLAY THEREOF**

Publication Classification

(75) Inventor: **Guofu Tang, Shenzhen (CN)**

(51) **Int. Cl.**
G02F 1/1335 (2006.01)
G09F 13/04 (2006.01)

(73) Assignee: **Shenzhen China Star Optoelectronic Technology Co. Ltd., Shenzhen (CN)**

(52) **U.S. Cl.** **349/61; 362/612**

(21) Appl. No.: **13/145,523**

(57) **ABSTRACT**

(22) PCT Filed: **Mar. 14, 2011**

(86) PCT No.: **PCT/CN11/74321**

§ 371 (c)(1),
(2), (4) Date: **Jul. 21, 2011**

This invention relates to a back light module and a liquid crystal display thereof. The back light module includes a rear panel, an LGP, a PCB, a plurality of LEDs and at least an elastic clamping fastener. The rear panel includes a base plate and at least a sidewall. The LGP is positioned on the base plate. The PCB opposite to the LGP is positioned on the sidewall of the rear panel. The LEDs are positioned on the PCB. At least an elastic clamping fastener successively passes through the rear panel and the PCB to fasten the rear panel and the PCB. In addition, the top of the elastic clamping fastener is higher than the surface of the LEDs. The back light module and the liquid crystal display thereof in this invention are simple in structure, convenient in assembly, and low in cost.

(30) **Foreign Application Priority Data**

Mar. 14, 2011 (CN) 201110060407.X

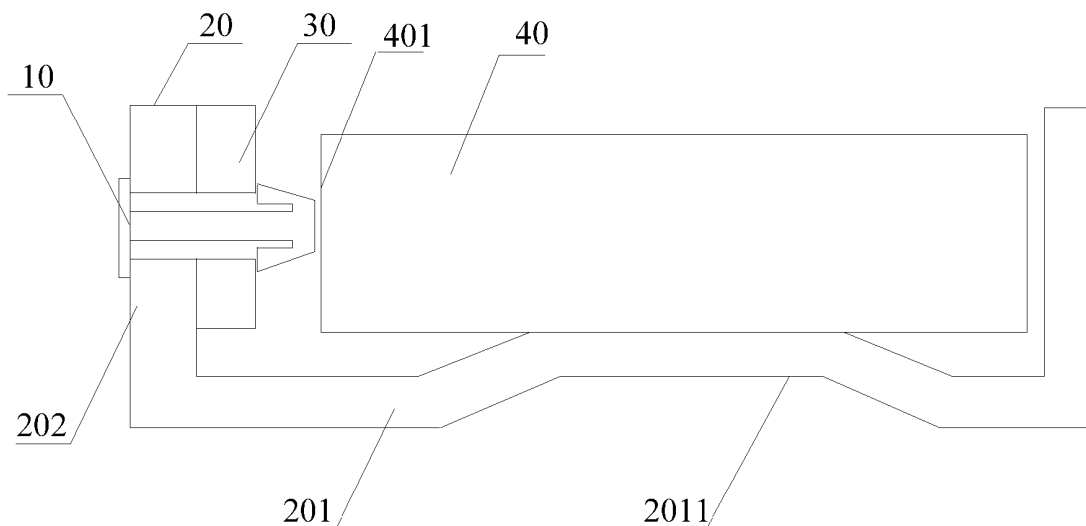

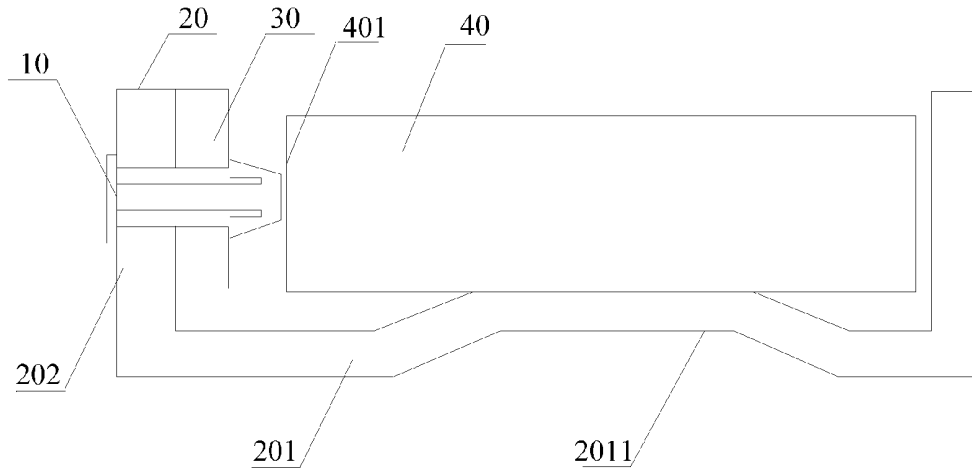

Figure 1

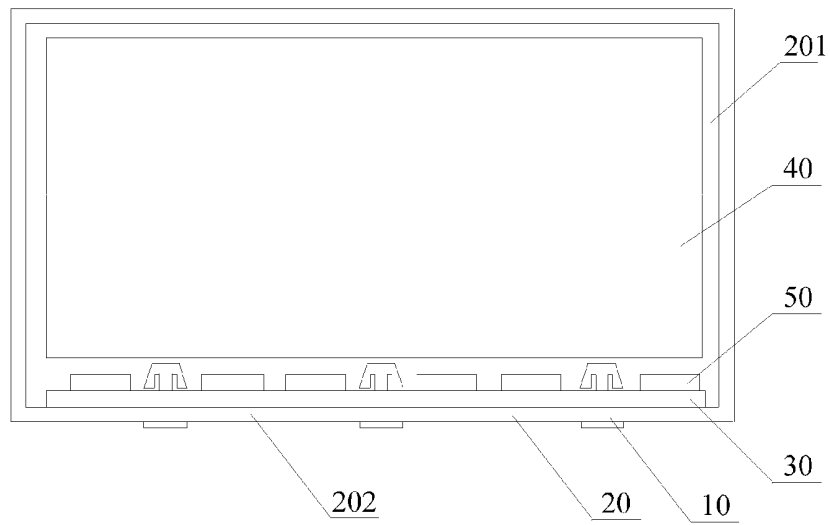

Figure 2

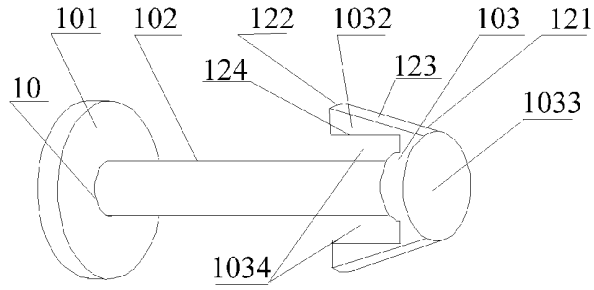

Figure 3

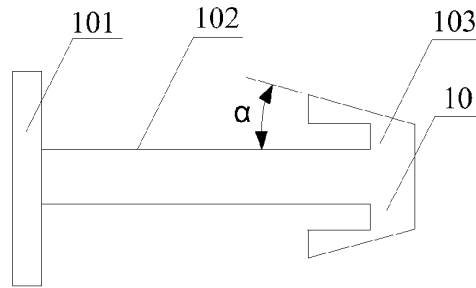

Figure 4

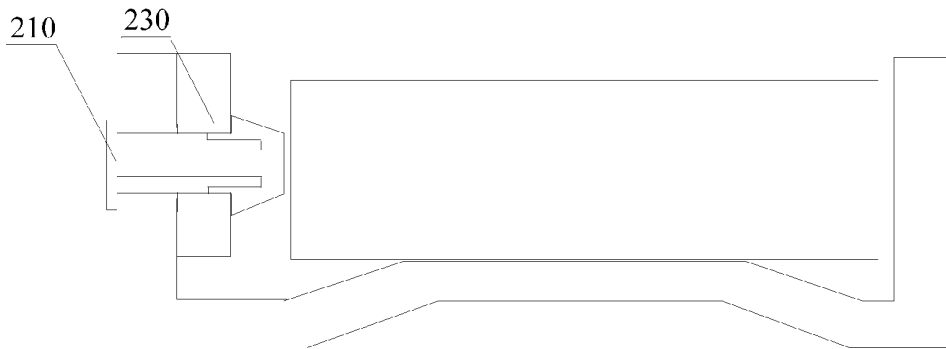

Figure 5

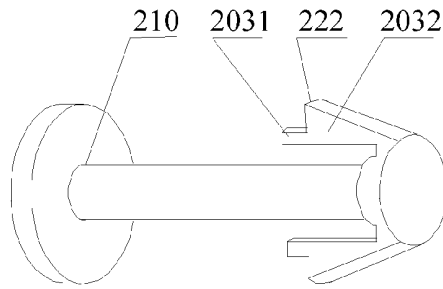

Figure 6

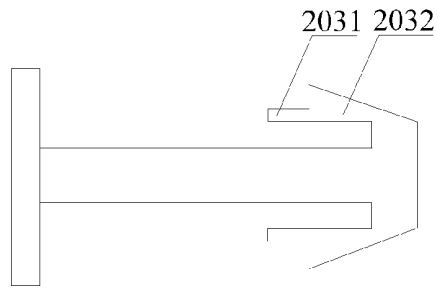

Figure 7

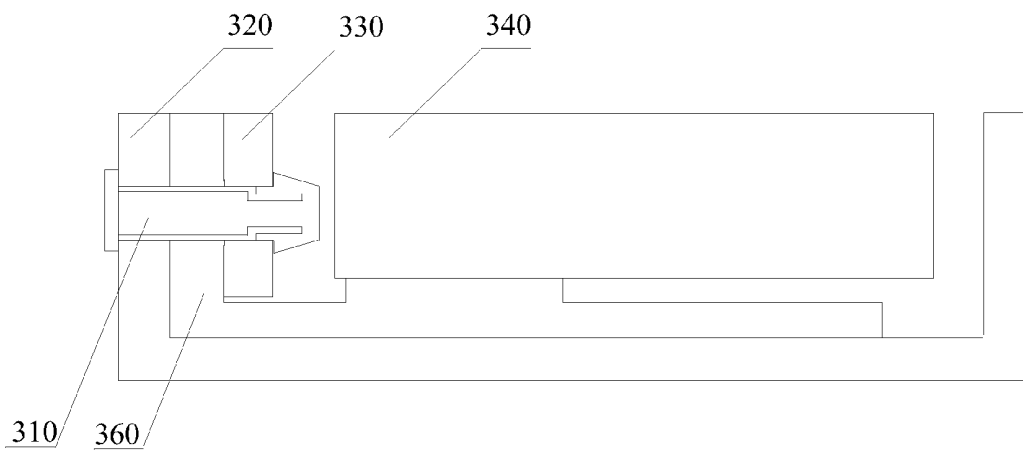

Figure 8

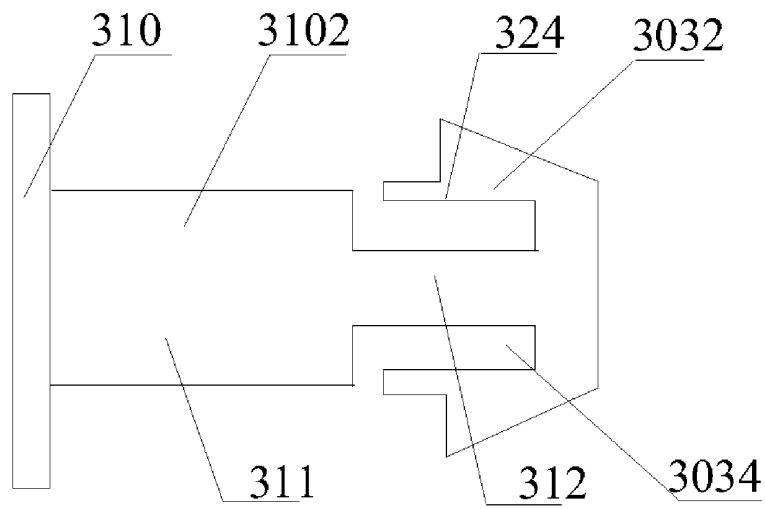

Figure 9

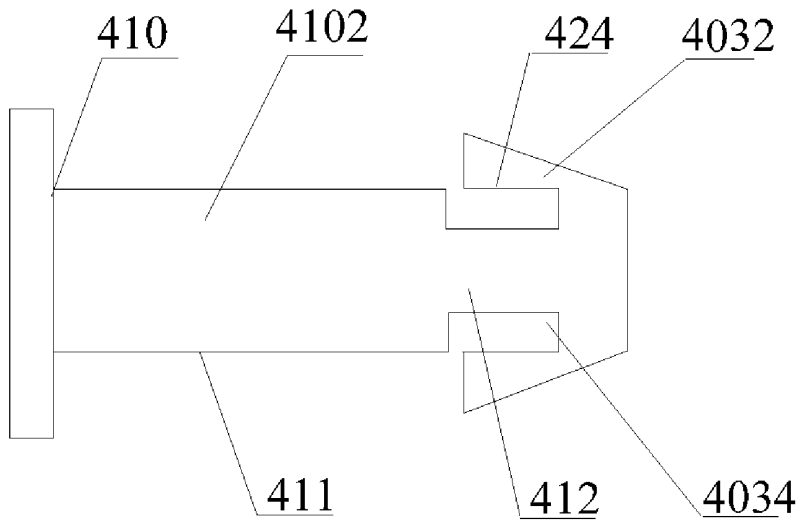

Figure 10

BACK LIGHT MODULE AND LIQUID CRYSTAL DISPLAY THEREOF

FIELD OF THE INVENTION

[0001] This invention relates to a back light module and an LCD thereof, in particular to a side-light type back light module and an LCD comprising the side-light type back light module.

BACKGROUND OF THE INVENTION

[0002] The existing back light module usually includes a light guide plate (LGP), a rear panel, a PCB (Printed Circuit Board), and a plurality of LEDs (Light Emitting Diodes) fixed on the PCB. Generally, there are two following kinds of fixed modes of the PCB: a, a heat conductive adhesive tape is pasted between the PCB and the rear panel; b, a screw is used to lock and attach the PCB and the rear panel. Wherein, the advantage of mode a is that the heat conductive adhesive tape can fill in the gap between the two interfaces, but the cost of the heat conductive adhesive tape is high. The mode b can reach the close contact of the two interfaces. The cost of the screw is lower than that of the heat conductive adhesive tape. However, the PCB is generally narrow and the adopted screw is relatively small, and thereby causing difficulties on locking and attaching task.

[0003] Besides, in the known side-light type back light module, the LGP usually positions left and right ends only by the rear panel to ensure a distance between the LGP and the LED surface. After the LGP is heated and expands, the swell capacity of the LGP in the central position of the module is the maximum, making a light input surface of the LGP directly support the LED surface. Since the surface temperature of the LED is extremely high, the LGP is easily melted.

[0004] Therefore, the technical problems including assembling difficulty, high cost, and easily melting of the LGP exist in the back light module of the prior art.

SUMMARY OF THE INVENTION

[0005] The main purpose of this invention lies in providing a back light module with convenient assembly, low cost, and the resistance of the LGP melting by the LED; this invention also provides an LED comprising the back light module.

[0006] A back light module includes a rear panel, an LGP, a PCB, and a plurality of LEDs. The rear panel includes a base plate and at least a sidewall. The LGP is positioned on the base plate. The LGP opposite to the PCB is positioned on the sidewall of the rear panel. The LEDs are positioned on the PCB. The back light module further includes at least an elastic clamping fastener. The elastic clamping fastener successively passes through the rear panel and the PCB to fasten the rear panel and the PCB. Besides, the top of the elastic clamping fastener is higher than the LED surface.

[0007] Preferably, the sidewall of the rear panel is equipped with at least a first through-hole. The PCB is equipped with at least a second through-hole opposite to the first through-hole. The elastic clamping fastener successively passes through the first through-hole and the second through-hole to fasten the rear panel and the PCB.

[0008] Preferably, the elastic clamping fastener includes a base plate, a fastener, and a long rod connecting the base plate and the fastener. The base plate is positioned on one side of the sidewall of the rear panel. The long rod is positioned in the

first through-hole and the second through-hole of the PCB. The fastener is positioned on one side of the PCB.

[0009] Preferably, the LGP includes a light input surface. The fastener includes a top. The surface of the top, a flat surface parallel to the light input surface of the LGP, is higher than the LED surface.

[0010] Preferably, the fastener further includes at least an elastic wedge-shaped protuberance. A first end of the elastic wedge-shaped protuberance connects the top and a second end is an elastic and bent free end. Preferably, the quantity of the elastic wedge-shaped protuberance is two and the two elastic wedge-shaped protuberances are symmetrical on the top.

[0011] Preferably, the outside surface of the elastic wedge-shaped protuberance is an inclined plane. The inclined plane and the long rod form an acute angle. There is a gap between the inside surface of the elastic wedge-shaped protuberance and the long rod. The gap is used to provide a bent space for the elastic wedge-shaped protuberance.

[0012] Preferably, the second end of the elastic wedge-shaped protuberance extends to form a bulge with the second through-hole of the PCB.

[0013] Preferably, the long rod includes a first part and a second part with unequal diameters. The diameter of the first part is equal to the diameter of the first through-hole and the second through-hole. The diameter of the second part is less than the diameter of the first part.

[0014] Preferably, under the state that the second end bends to the maximum, the outside surface of the elastic wedge-shaped protuberance is a flat surface parallel to the long rod. The distance between the two outside surfaces of elastic and bent wedge-shaped protuberance is equal to the diameter of the first through-hole and the second through-hole.

[0015] Preferably, the distance between the outsides of the bulges of the two elastic wedge-shaped protuberances is greater than the diameter of the second through-hole of the PCB.

[0016] Preferably, the elastic clamping fastener is equipped by intervals with the two LEDs.

[0017] Preferably, the base plate of the rear panel is equipped with a bulge to support the LGP. The bulge is used to make the LGP positioned in the height opposite to the LED.

[0018] Preferably, a cooling fin is equipped between the PCB and the rear panel. The elastic clamping fastener successively passes through the rear panel, the cooling fin, and the PCB to fasten the PCB and the rear panel.

[0019] Preferably, the base plate of the rear panel is a surface plate. The corresponding position of the base plate of the cooling fin is equipped with the protuberance to support the LGP in order to make the LGP positioned in the height opposite to the LED.

[0020] An LED includes a LED panel and a back light module. The back light module includes a rear panel, an LGP, a PCB, and a plurality of LEDs. The rear panel includes a base plate and at least a sidewall. The LGP is positioned on the base plate. The LGP opposite to the PCB is equipped on the sidewall of the rear panel. A plurality of LEDs are equipped on the PCB, which is characterized in that the back light module further includes at least an elastic clamping fastener. The at least one elastic clamping fastener successively passes through the rear panel and the PCB to fasten the rear panel and the PCB. Besides, the top of the elastic clamping fastener is higher than the LED surface.

[0021] Preferably, the sidewall of the rear panel is equipped at least a first through-hole. The PCB is equipped with at least a second through-hole opposite to the first through-hole. The elastic clamping fastener successively passes through the first through-hole and the second through-hole to fasten the rear panel and the PCB.

[0022] Preferably, the elastic clamping fastener includes a base plate, a fastener, and a long rod connecting the base plate and the fastener. The base plate is positioned on one side of the sidewall of the rear panel. The long rod is positioned in the first through-hole and the second through-hole of the PCB. The fastener is positioned on one side of the PCB.

[0023] Preferably, the LGP includes a light input surface. The fastener includes a top. The surface of the top, a flat surface parallel to the light input surface of the LGP, is higher than the LED surface.

[0024] Preferably, the fastener further includes at least an elastic wedge-shaped protuberance. A first end of the at least one elastic wedge-shaped protuberance connects the top; a second end is an elastic and bent free end.

[0025] Compared with the prior art, this invention provides the back light module and the LED thereof, and adopts the elastic clamping fastener to fasten the PCB and the rear panel. At the same time, since the elastic clamping fastener is higher than the LED surface, the LGP firstly contacts the top of the elastic clamping fastener and the top supports the LGP when the LGP deforms due to reasons such as thermal expansion or assembling allowance etc., which avoids that the LGP is melted when touching the high-temperature surface of the LED. With low cost, the back light module of this invention is easily assembled and can prevent the LGP from melting.

DESCRIPTION OF ATTACHED DRAWINGS

[0026] FIG. 1 is the section view enlarged drawing of the first embodiment of the back light module of this invention;

[0027] FIG. 2 is the top view of the back light module shown in FIG. 1;

[0028] FIG. 3 is the solid enlarged drawing of the elastic clamping fastener in the first embodiment of the back light module of this invention;

[0029] FIG. 4 is the main view enlarged drawing of the elastic clamping fastener shown in FIG. 3;

[0030] FIG. 5 is the section view enlarged drawing of the second embodiment of the back light module of this invention;

[0031] FIG. 6 is the solid enlarged drawing of the elastic clamping fastener in the second embodiment of the back light module of this invention;

[0032] FIG. 7 is the main view enlarged drawing of the elastic clamping fastener shown in FIG. 6;

[0033] FIG. 8 is the section view enlarged drawing of the third embodiment of the back light module of this invention;

[0034] FIG. 9 is the main view enlarged drawing of the elastic clamping fastener in the third embodiment of the back light module of this invention;

[0035] FIG. 10 is the main view enlarged drawing of the elastic clamping fastener in the fourth embodiment of the back light module of this invention; and

[0036] The purpose realization, functional characteristics, and advantages of this invention will combine the embodiments and be further stated referring to the figures.

DETAILED DESCRIPTION OF THE EMBODIMENTS

[0037] As shown in FIG. 1 and FIG. 2, the back light module of an embodiment of this invention includes: an LGP 40, a PCB 30, a rear panel 20, a plurality of LEDs 50 and at least a elastic clamping fastener 10. Wherein, the rear panel 20 includes a base plate 201 and a sidewall 202. The LGP 40 is positioned on the base plate 201. The LGP 40 includes a light input surface 401, a bottom surface (not labeled) and a light output surface (not labeled) opposite to the bottom surface. The PCB 30 is positioned in the internal surface of the sidewall 202 of the rear panel 20. The PCB 30 is opposite to the light input surface 401 of the LGP 40.

[0038] A plurality of LEDs 50 is arranged on the PCB 30, which is opposite to the light input surface 401 of the LGP 40. The base plate 201 of the rear panel 20 is equipped with a bulge 2011 supporting the LGP 40 to make the LGP 40 be positioned in the height opposite to the LED 50. The elastic clamping fastener 10 is equipped by intervals with every two LEDs 50. The material of the elastic clamping fastener 10 can be plastic materials or metal materials.

[0039] The sidewall 202 of the rear panel 20 is equipped with a plurality of first through-holes (not labeled). The PCB 30 is equipped with a plurality of second through-holes (not labeled) opposite to the first through-holes; the elastic clamping fastener 10 successively passes through the first through-hole of the rear panel 10 and the second through-hole of the PCB 30 to fasten the rear panel 10 and the PCB 30. The first through-hole and the second through-hole are round through-holes with the same semi diameter.

[0040] Specifically, please refer to FIG. 3 and FIG. 4 together. The elastic clamping fastener 10 of the first embodiment includes a base plate 101, a fastener 103, and a long rod 102 connecting the base plate 101 and the fastener 103. The base plate 101 is positioned on an outside surface of the sidewall 202 of the rear panel 20; the long rod 102 is positioned in the first through-hole of the sidewall 202 and the second through-hole of the PCB 30; the fastener 103 is positioned on the surface of the PCB 30. The long rod 102 is a cylinder with the semi diameter less than the first through-hole and the second through-hole.

[0041] The fastener 103 includes a top 1033 and two elastic wedge-shaped protuberances 1032. The top 1033 is approximately a circular disk shape. The surface (not labeled) of the top 1033 is a flat surface parallel to the light input surface 401 of the LGP 40, and higher than the surface of the LED 50 to press the LGP 40 while the LGP is expanding, which will not damage the light input surface 401 thereof either. The two elastic wedge-shaped protuberances 1032 are symmetrical on the top. A first end 121 of the elastic wedge-shaped protuberances 1032 connects the top 1033 and a second end 122 is an elastic and bent free end. Under the natural state, the outside surface 123 of the elastic wedge-shaped protuberances 1032 is an inclined plane. The inclined plane and the long rod 102 form an acute angle α . There is a gap 1034 between the inside surface 124 of the elastic wedge-shaped protuberances 1032 and the long rod 102. The gap 1034 is used to provide an elastic and bent space for the elastic wedge-shaped protuber-

ances **1032**. Therefore, the elastic wedge-shaped protuberances **1032** can pass through the first through-hole and the second through-hole.

[0042] Under the state that the second end **122** bends to the maximum, the outside surface **123** of the elastic wedge-shaped protuberances **1032** is approximately a flat surface parallel to the long rod **102**. At this moment, the distance of the outside surface **123** between the two elastic and bent wedge-shaped protuberances **1032** is approximately equal to the diameter of the first through-hole and the second through-hole.

[0043] Compared with the prior art, the back light module of this invention fastens the PCB **30** and the rear panel **20** through the elastic clamping fastener **10**. At the same time, since the top **1033** of the elastic clamping fastener **10** is higher than the surface of the LED **50**, the LGP **40** first touches the top **1033** of the elastic clamping fastener **10** and the top **1033** resists against the LGP **40** when the LGP **40** deforms due to reasons such as thermal expansion or assembling allowance et al., which can avoid that the LGP **40** is melted when touching the high-temperature surface of the LED **50**. With low cost, the back light module of this invention is easily assembled and can prevent the LGP **40** from melting.

[0044] Please refer to FIG. 5, FIG. 6 and FIG. 7. The back light module of the second embodiment in this invention is similar to the above first embodiment. The difference is that the elastic clamping fastener **210** structures are different. The elastic clamping fastener **210** of the embodiment is similar to the elastic clamping fastener **10** of the first embodiment. The difference is that the second end **222** of the elastic wedge-shaped protuberance **2032** is extended to form a bump **2031**. The distance between the exterior sides of the two bumps **2031** of the two elastic wedge-shaped protuberances **2032** is slightly larger than the diameter of the second through-hole (not numbered) of the PCB **230**, so that the bump **2031** is clamped in the internal of the second through-hole (not numbered) to play a better role in positioning.

[0045] Please refer to FIG. 8. The back light module of the third embodiment in this invention is similar to that of the first embodiment. The difference is that the back light module further arranges a cooling fin **360** between the PCB **330** and the rear panel **320**. The elastic clamping fastener **310** successively passes through the rear panel **320**, the cooling fin **360** and the PCB **330** and fixes the PCB **330** and the rear panel **320**. The bottom board of the rear panel **320** is flat. A protuberance to support the LGP **340** is arranged in the corresponding position on the bottom of the cooling fin **360** to position the LGP **340** in the height relative to the LED.

[0046] Please refer to FIG. 9. The elastic clamping fastener **310** of the back light module of the third embodiment in this invention is similar to the elastic clamping fastener **210** of the second embodiment. The difference is that the long rod **3102** includes a first part **311** and a second first part **312** with different diameters. The first part **311** is positioned in the first through-hole of the sidewall (not labeled) of the rear panel **320** and the second through-hole (not labeled) of the PCB **330**. The diameter of the first part **311** basically equals to that of the first through-hole and the second through-hole, so that the elastic clamping fastener can fix the rear panel **320** and the PCB **330** more firmly. The second part **312** is positioned on one side of the PCB **330** and the diameter of the second part **312** is smaller than that of the first part **311**, so that a space **3034** for the elastic wedge-shaped protuberance **3032** to bend

can be formed between the second part **312** and the interior surface **324** of the elastic wedge-shaped protuberance **3032**.

[0047] Please refer to FIG. 10. The elastic clamping fastener **410** of the back light module of the fourth embodiment in this invention is similar to the elastic clamping fastener **10** of the first embodiment. The difference is that the long rod **4102** includes a first part **411** and a second part **412** with different diameters. The first part **411** is positioned in the first through-hole (not shown in the figure) of the sidewall of the rear panel (not shown in the figure) and the second through-hole (not shown in the figure) of the PCB (not shown in the figure). The diameter of the first part **411** basically equals to that of the first through-hole and the second through-hole, so that the elastic clamping fastener **410** can fix the rear panel and the PCB more firmly. The second part **412** is positioned on one side of the PCB and the diameter of the second part **412** is smaller than that of the first part **411**, so that a space **4034** for the elastic wedge-shaped protuberance **4032** to bend can be formed between the interior surfaces of the second part **412** and the elastic wedge-shaped protuberance **4032**.

[0048] The back light module of this invention is not limited to the above embodiments. For example, the elastic clamping fastener of every embodiment can be applied in the back light module of the third embodiment; in the above embodiments, the base plate **101** can be round as well as quadrate, rectangular and polyilateral, etc.

[0049] In the above embodiments, the number of the elastic wedge-shaped protuberances **1032**, **2032**, **3032** and **4032** can be one or more than 3. The long rod **102** of the elastic clamping fastener **10** of the first embodiment can also be cuboids, etc., correspondingly, the first through-hole of the sidewall **202** of the rear panel **20** and the second through-hole of the PCB **30** can also be rectangular, etc.

[0050] Furthermore, this invention also puts forward one kind of the liquid crystal display, which includes a liquid crystal panel and the back light module of the above embodiments. Here, we will not go further on them.

[0051] The embodiments mentioned as above are only the preferential embodiments of this invention, and can not limit the patent claim. The equivalent structure or flow change formed by using the description of this invention and contents of drawings, or direct or indirect application to other relevant technical fields, are all included in the extent of patent protection of this invention.

What is claimed is:

1. A back light module comprising a rear panel, an LGP, a PCB and a plurality of LEDs, the rear panel comprising a base plate and at least one sidewall, the LGP being positioned on the base plate, the PCB being positioned on the sidewall of the rear panel, and the LEDs being positioned on the PCB, wherein the back light module further comprises at least one elastic clamping fastener which successively passes through the rear panel and the PCB to fasten the rear panel and the PCB, the top of the elastic clamping fastener is higher than the surface of the LEDs.

2. The back light module as claimed in claim 1, wherein at least one first through-hole is arranged on the sidewall of the rear panel, at least one second through-hole corresponding to the first through-hole is arranged on the PCB, and the elastic clamping fastener successively passes through the first through-hole and the second through-hole to fasten the rear panel and the PCB.

3. The back light module as claimed in claim 2, wherein the elastic clamping fastener comprises a base plate, a fastener

and a long rod connecting the base plate and the fastener, the base plate is positioned on one side of the sidewall of the rear panel, the long rod is positioned in the first through-hole and the second through-hole of the PCB, and the fastener is positioned on one side of the PCB.

4. The back light module as claimed in claim **3**, wherein the LGP comprises a light input surface, the fastener comprises a top, and the surface of the top is higher than that of the LED and is parallel to the light input surface of the LGP.

5. The back light module as claimed in claim **4**, wherein the fastener further comprises at least one elastic wedge-shaped protuberance, the first end of which is connected to the top, and the second end is a free end which can be bent elastically.

6. The back light module as claimed in claim **5**, wherein there are two elastic wedge-shaped protuberances, which are symmetrical centered on the top.

7. The back light module as claimed in claim **5**, wherein the surface of the exterior side of the elastic wedge-shaped protuberance is a slope, an acute angle is formed between the slope and the long rod, a gap is formed between the surface of the interior side of the elastic wedge-shaped protuberance and the long rod, and the gap is used to provide a bent space for the elastic wedge-shaped protuberance.

8. The back light module as claimed in claim **5**, wherein the second end of the elastic wedge-shaped protuberance is extended to form a bump which is clamped in the second through-hole of the PCB.

9. The back light module as claimed in claims **8**, wherein the long rod comprises a first part and a second part with different diameters, the diameter of the first part equals to that of the first through-hole and the second through-hole, and the diameter of the second part is smaller than that of the first part.

10. The back light module as claimed in claim **8**, wherein in the status that the second end is bent to the greatest extent, the surface of the exterior side of the elastic wedge-shaped protuberance is a flat surface parallel to the long rod, and a distance between the surfaces of the exterior side of the two bent elastic wedge-shaped protuberances equals to diameters of the first through-hole and the second through-hole.

11. The back light module as claimed in claim **10**, wherein the distance between exterior sides of the bumps of the two elastic wedge-shaped protuberances is larger than the diameter of the second through-hole of the PCB.

12. The back light module as claimed in claim **1**, wherein the elastic clamping fastener is equipped by intervals with the two LEDs.

13. The back light module as claimed in claim **1**, wherein the protuberance to support the LGP is arranged on the base plate of the rear panel, which is used to position the LGP in the height relative to the LED.

14. The back light module as claimed in claim **1**, wherein a cooling fin is arranged between the PCB and the rear panel, and the elastic clamping fastener successively passes through the rear panel, the cooling fin and the PCB to fasten the PCB and the rear panel.

15. The back light module as claimed in claim **14**, wherein the base plate of the rear panel is flat, and a protuberance to support the LGP is arranged in the corresponding position of the base of the cooling fin so as to position the LGP in the height relative to the LED.

16. A liquid crystal display, comprising a liquid crystal display board and a back light module, the back light module comprising a rear panel, an LGP, a PCB and a plurality of LEDs, the rear panel comprising a base plate and at least a sidewall, the LGP being positioned on the base plate, the PCB being arranged on the sidewall of the rear panel, and the LEDs being arranged on the PCB, wherein the back light module further comprises at least an elastic clamping fastener, which successively passes through the rear panel and the PCB to fasten the rear panel and the PCB, the top of the elastic clamping fastener is higher than the surface of the LEDs.

17. The liquid crystal display as claimed in claim **16**, wherein at least a first through-hole is arranged on the sidewall of the rear panel, at least a second through-hole is arranged on the PCB corresponding to the first through-hole, and the elastic clamping fastener successively passes through the first through-hole and the second through-hole to fasten the rear panel and the PCB.

18. The liquid crystal display as claimed in claim **17**, wherein the elastic clamping fastener comprises a base plate, a fastener and a long rod connecting the base plate and the fastener, the base plate is positioned on one side of the sidewall of the rear panel, the long rod is positioned in the first through-hole and the second through-hole of the PCB, and the fastener is positioned on one side of the PCB.

19. The liquid crystal display as claimed in claim **18**, wherein the LGP comprises a light input surface, and the fastener comprises a top, the surface of which is higher than that of the LED and is a surface parallel to the light input surface of the LGP.

20. The liquid crystal display as claimed in claim **19**, wherein the fastener further comprises at least an elastic wedge-shaped protuberance, the first end of which is connected to the top and the second end is a free end which can be bent elastically.

* * * * *

专利名称(译)	背光模块及其液晶显示器		
公开(公告)号	US20120236228A1	公开(公告)日	2012-09-20
申请号	US13/145523	申请日	2011-03-14
[标]申请(专利权)人(译)	深圳市中国星OPTOELECTRONICSE TECH		
申请(专利权)人(译)	深圳市中国星OPTOELECTRONICE TECHNOLOGY CO.LTD.		
当前申请(专利权)人(译)	深圳市中国星OPTOELECTRONICE TECHNOLOGY CO.LTD.		
[标]发明人	TANG GUOFU		
发明人	TANG, GUOFU		
IPC分类号	G02F1/1335 G09F13/04		
CPC分类号	F21S8/00 F21V17/16 G02F1/1335 G02F1/133615 G02B6/009 G02F2001/133612 G02F2201/465 G02B6/0088 G09F13/04		
优先权	201110060407.X 2011-03-14 CN		
其他公开文献	US8520162		
外部链接	Espacenet USPTO		

摘要(译)

背光模块及其液晶显示器本发明涉及一种背光模块及其液晶显示器。背光模块包括后面板，LGP，PCB，多个LED和至少一个弹性夹紧紧固件。后面板包括底板和至少一个侧壁。LGP位于底板上。与LGP相对的PCB位于后面板的侧壁上。LED位于PCB上。至少一个弹性夹紧紧固件连续穿过后面板和PCB，以紧固后面板和PCB。另外，弹性夹紧紧固件的顶部高于LED的表面。本发明的背光模块及其液晶显示器结构简单，组装方便，成本低廉。

