



US 20060092112A1

(19) **United States**

(12) **Patent Application Publication**
Moon

(10) **Pub. No.: US 2006/0092112 A1**

(43) **Pub. Date: May 4, 2006**

(54) **LIQUID CRYSTAL DISPLAY APPARATUS
AND METHOD FOR DRIVING THE SAME**

Publication Classification

(75) Inventor: **Seung-Hwan Moon, Seoul (KR)**

(51) **Int. Cl.**
G09G 3/36 (2006.01)

(52) **U.S. Cl.** **345/87**

Correspondence Address:
F. CHAU & ASSOCIATES, LLC
130 WOODBURY ROAD
WOODBURY, NY 11797 (US)

(57) **ABSTRACT**

A liquid crystal display is provided. The display includes: a data driver for outputting image signals; a gate driver for sequentially outputting scanning signals; a liquid crystal panel including a switching element for controlling the image signal in response to the scanning signal, a liquid crystal capacitor driven by a voltage difference between the image signal and a common electrode voltage, and a storage capacitor for accumulating the charge of image signal when the switching element is on, and applying the accumulated image signal to the liquid crystal capacitor when the switching element is turned off; a distortion detector for detecting the common electrode voltage applied to the liquid crystal capacitor and outputting a common electrode distortion voltage; and an offset voltage generator for outputting an offset voltage to increase a rate of charge of the storage capacitor based on the common electrode distortion voltage.

(73) Assignee: **Samsung Electronics Co., Ltd.**

(21) Appl. No.: **11/300,148**

(22) Filed: **Dec. 14, 2005**

Related U.S. Application Data

(63) Continuation of application No. 10/107,716, filed on Mar. 27, 2002, now Pat. No. 7,015,890.

(30) **Foreign Application Priority Data**

Sep. 25, 2001 (KR) 2001-59319

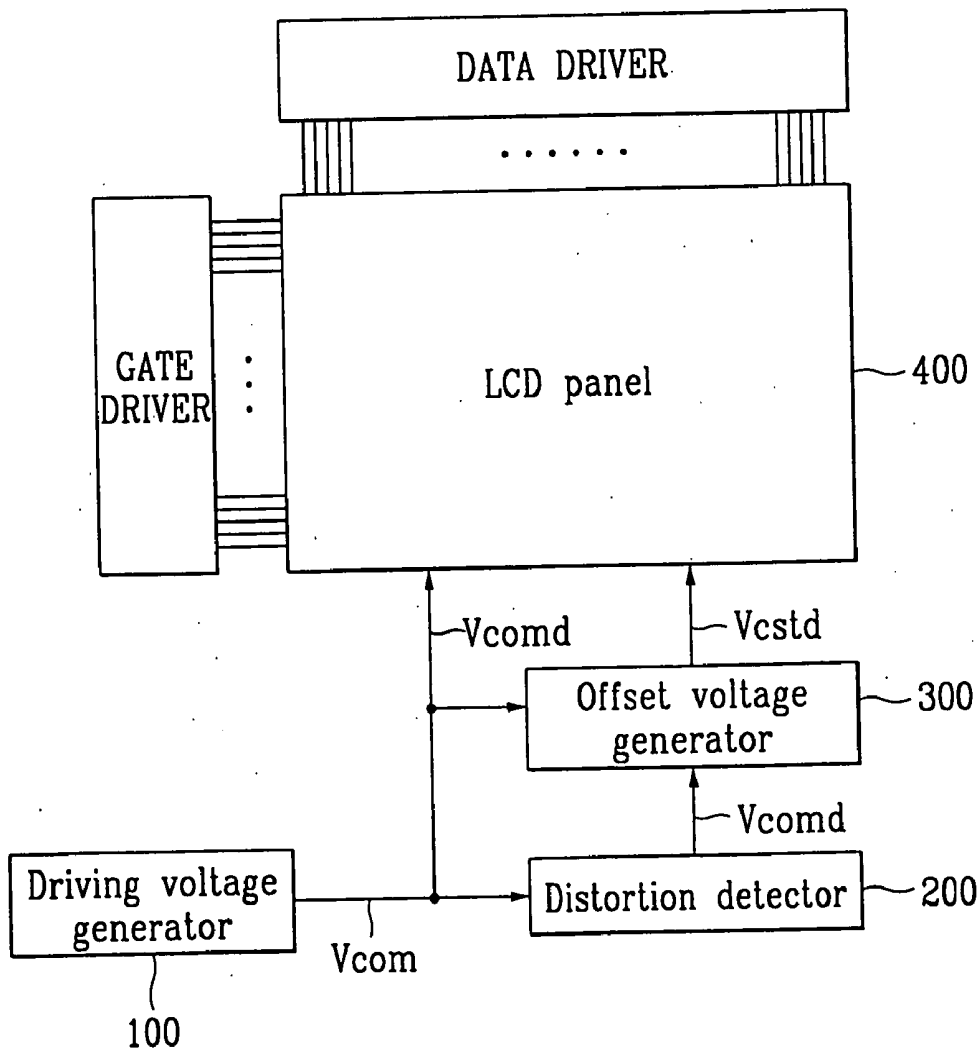

FIG.1

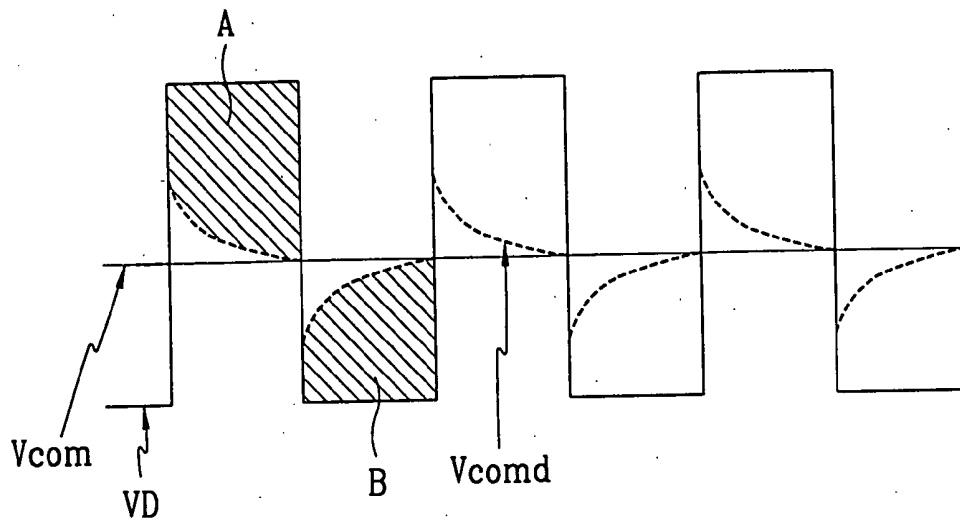

FIG.2

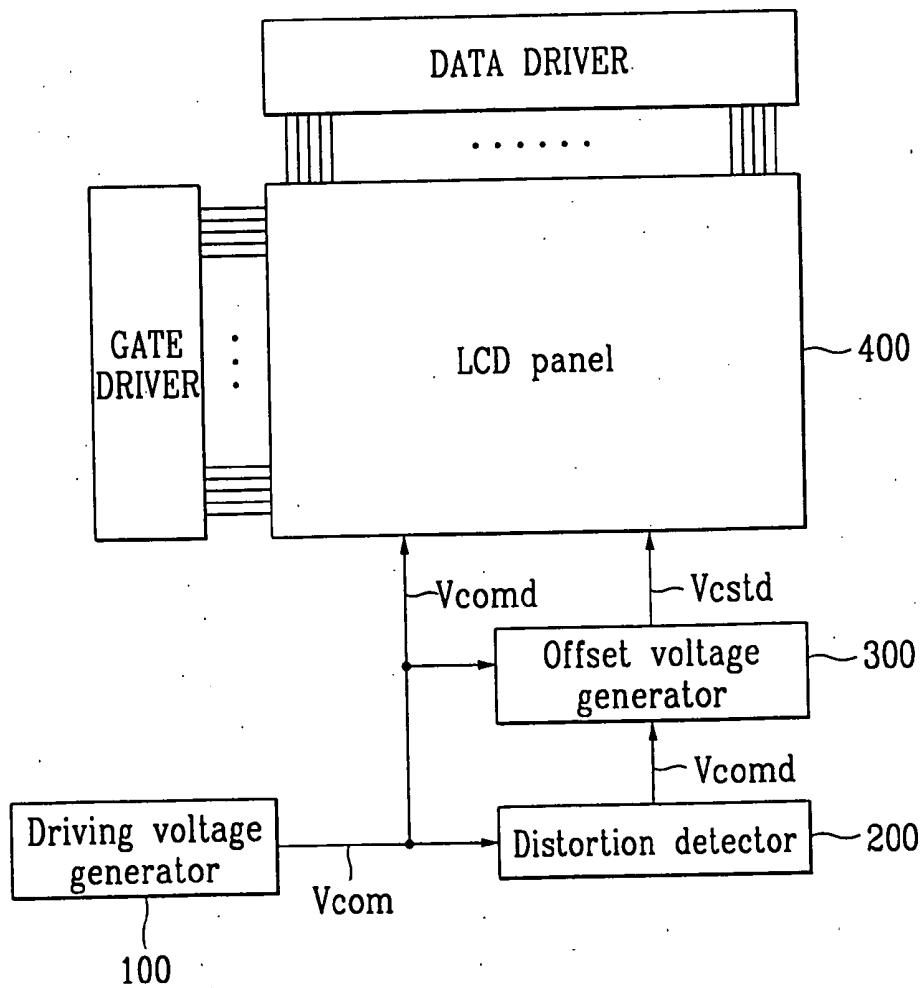

FIG. 3

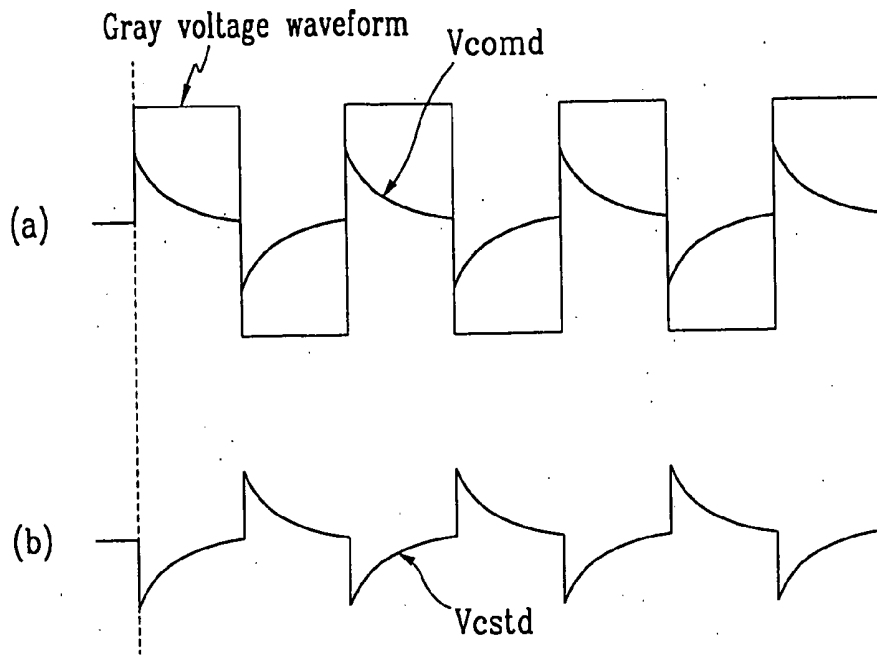

FIG. 4

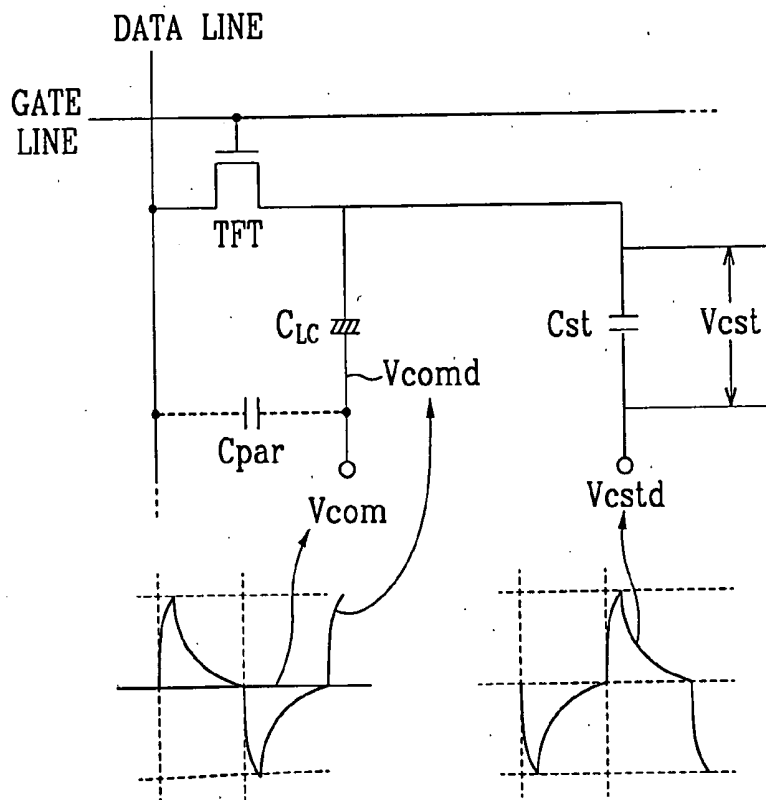

FIG.5A

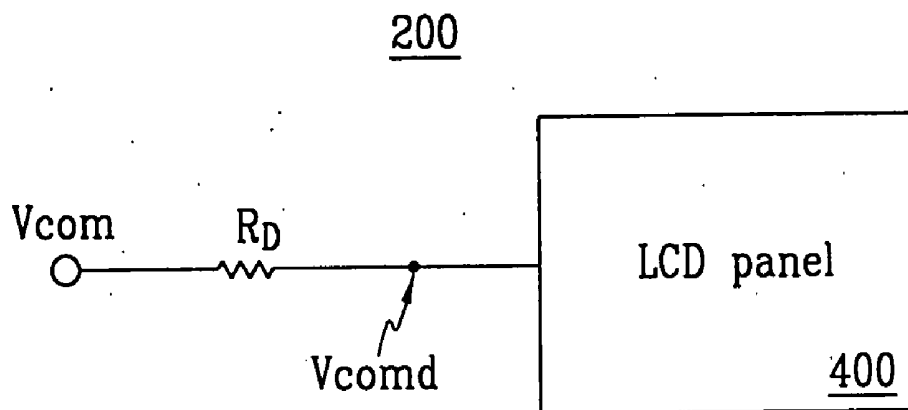

FIG.5B

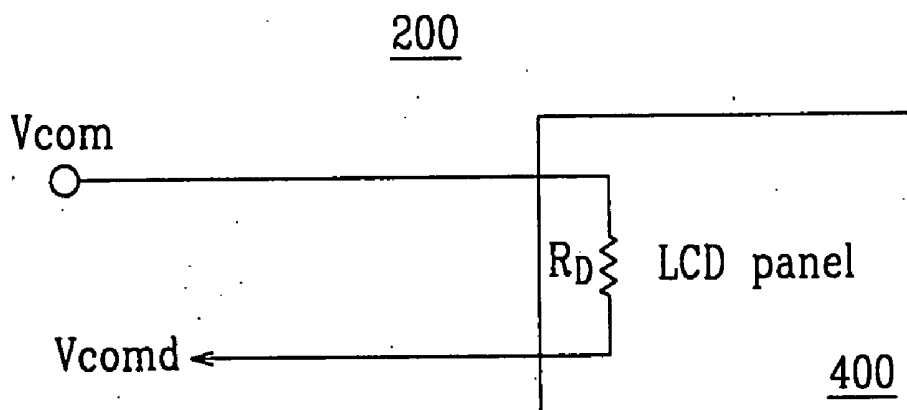

FIG. 6A

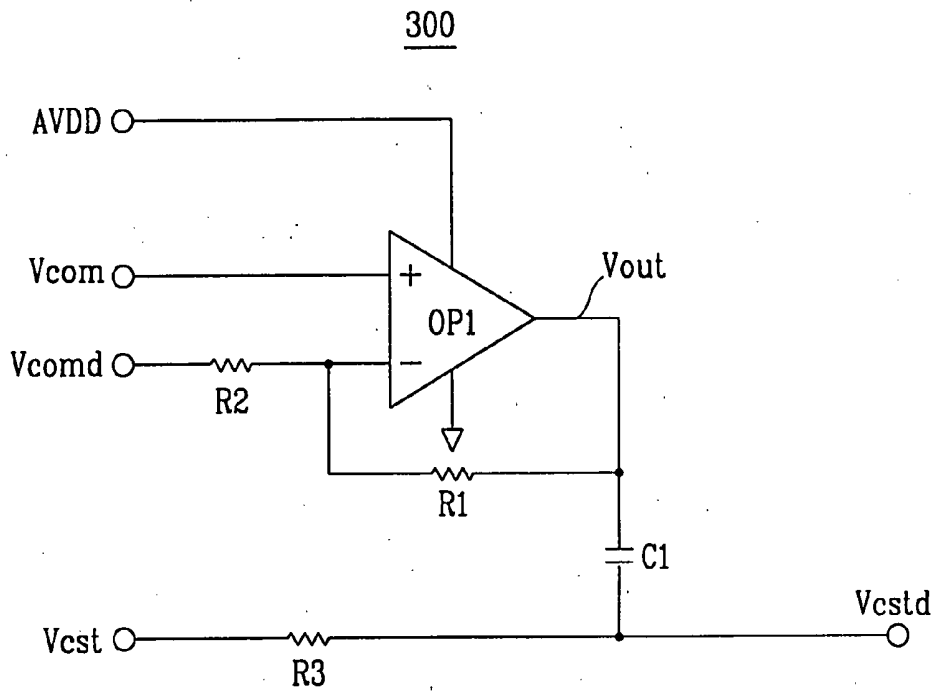

FIG. 6B

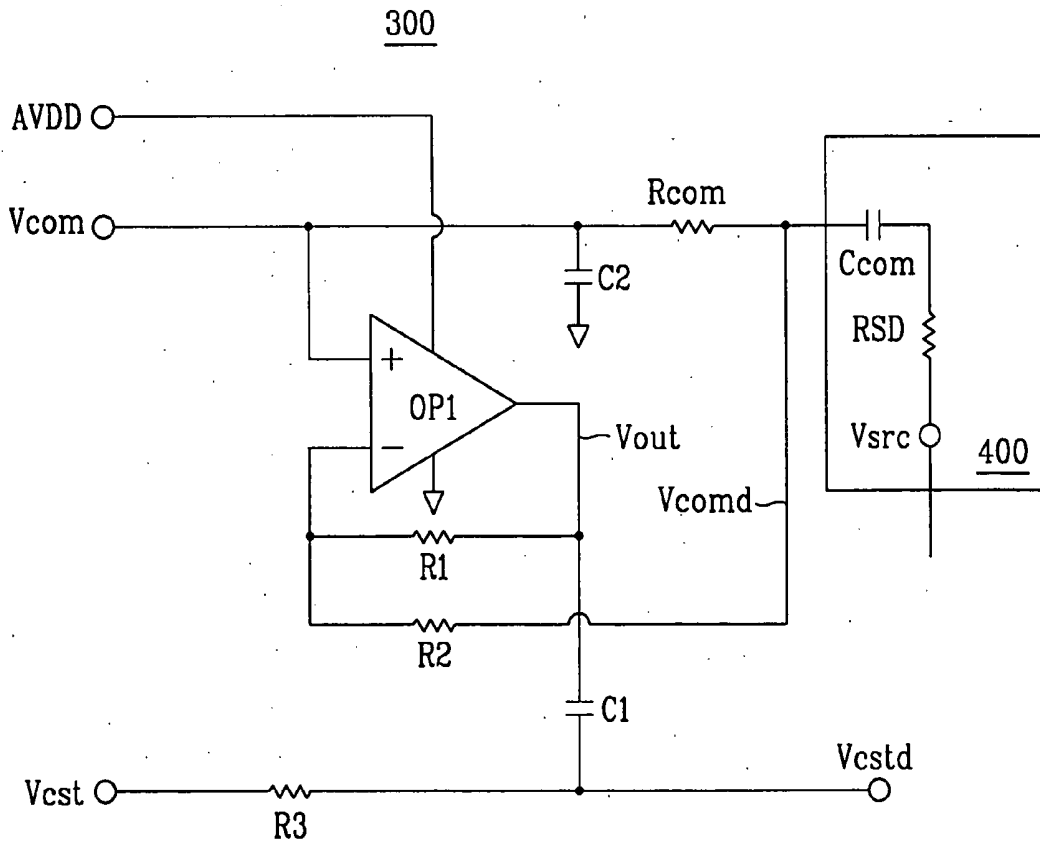
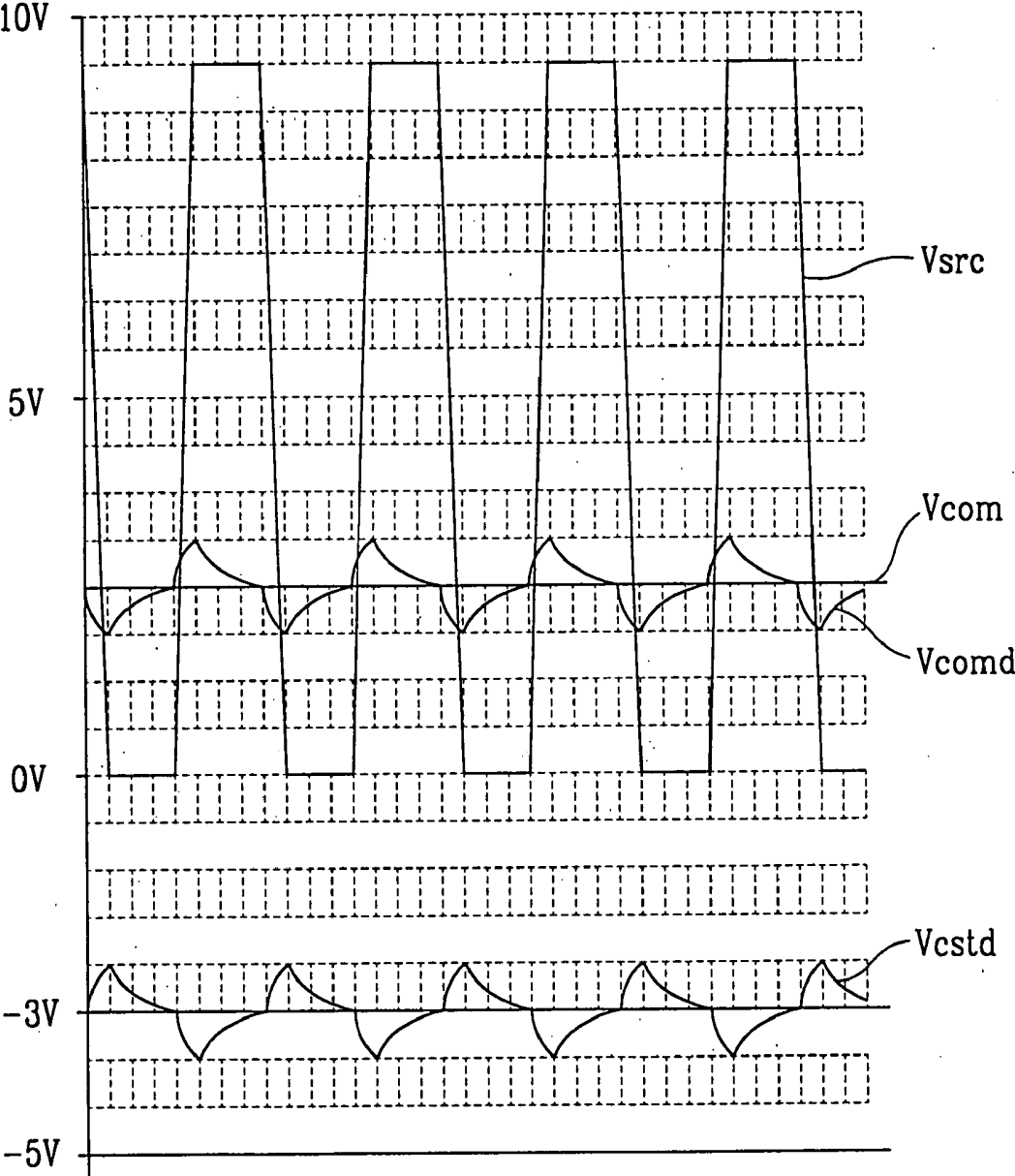

FIG. 7



LIQUID CRYSTAL DISPLAY APPARATUS AND METHOD FOR DRIVING THE SAME

CROSS-REFERENCE TO RELATED APPLICATIONS

[0001] This application is a continuation of application Ser. No. 10/107,716 filed Mar. 27, 2002, which claims priority to Korean Patent Application No. 2001-59319 filed Sep. 25, 2001, the disclosure of which in its entirety is incorporated by reference herein.

BACKGROUND OF THE INVENTION

[0002] (a) Field of the Invention

[0003] The present invention relates to a liquid crystal display apparatus and a method for driving the same, and more specifically, an apparatus and a method for driving the liquid crystal display with reduced crosstalk and distortion.

[0004] (b) Description of the Related Art

[0005] Liquid crystal display is widely used for flat panel display devices in many applications. Generally, the liquid crystal display has two substrates with electrodes, and a liquid crystal layer interposed between the two substrates. Each of the two substrates is sealed by a sealer while being spaced apart from each other by spacers. A voltage is applied to the electrodes so that the liquid crystal molecules in the liquid crystal layer are re-oriented to thereby control an amount of light transmission through the liquid crystal layer. Thin film transistors are provided at one of the substrates to control the signals transmitted to the electrodes.

[0006] It is known that the operations of a liquid crystal display depend at least in part on the turning on and off of electric fields applied to liquid crystals. Crosstalk is the interfering effect from signals or noise generated by the turning on and off of the electric field or transmitted signals.

[0007] In a liquid crystal display, crosstalk is also generated from the charging and discharging of pixels, which is proportional to the difference between an input gray voltage at a data line and a common electrode voltage. The distortion of the common electrode voltage may prevent pixels from reducing a desired gray voltage.

[0008] The distortion of the common electrode voltage is usually caused by a parasitic capacitance between a data line (horizontal resolution \times 3) in the liquid crystal display and a common electrode in the upper liquid crystal display panel. More specifically, the distortion typically occurs when the gray voltage at the data line rises or falls and the common electrode voltage is coupled to the rising or falling voltage. Uncontrolled crosstalk or distortion adversely affects the picture quality of the liquid crystal display. **FIG. 1** shows a waveform of a signal having crosstalk. Referring to **FIG. 1**, the pixel charging state is determined in proportion to the area related to the difference between the gray voltage level and the common electrode voltage level, with area A having larger amplitude of the gray voltage waveform as compared to area B. This difference in areas A and B causes variations in the charging rate, such as in the intermediate gray voltage. Accordingly, a need exists for a liquid crystal display having an anti-crosstalk function to thereby secure a constant charging rate of a pixel of the liquid crystal display.

SUMMARY OF THE INVENTION

[0009] A liquid crystal display is provided, which includes: a data driver for outputting an image signal; a gate driver for sequentially outputting a scanning signal; a liquid crystal display panel including a plurality of pixels for displaying an image, the plurality of pixel having a switching element for controlling the image signal in response to the scanning signal, a liquid crystal capacitor driven by a voltage difference between the image signal received at one terminal thereof and a common electrode voltage received at another terminal thereof, and a storage capacitor for accumulating the charge of image signal received at the one terminal thereof when the switching element is turned on, and applying the accumulated image signal to the liquid crystal capacitor via the one terminal thereof when the switching element is turned off; a distortion detector for detecting the common electrode voltage applied to the other terminal of the liquid crystal capacitor and outputting a common electrode distortion voltage; and an offset voltage generator for outputting an offset voltage to change a rate of charge of the storage capacitor based on the common electrode distortion voltage.

[0010] According to an embodiment of the present invention, the distortion detector includes a detection resistor for detecting the common electrode voltage and outputting the common electrode distortion voltage. The distortion detector detects a potential difference between both terminals of the detection resistor. The distortion detector detects a potential difference between both terminals of an internal resistor of the liquid crystal panel applied to the common electrode voltage and outputs the common electrode distortion voltage. The offset voltage generator receives the common electrode voltage at a non-inverting terminal thereof and the common electrode distortion voltage at an inverting terminal thereof, and outputs the offset voltage at an output terminal thereof.

[0011] According to an embodiment of the present invention, the offset voltage generator includes: an OP amplifier for receiving the common electrode voltage at a non-inverting terminal thereof and the common electrode distortion voltage at an inverting terminal thereof, and outputting an output voltage at an output terminal thereof to a DC component remover; and a DC component remover for removing a DC component of the output voltage and outputting an AC offset voltage. The offset voltage is in antiphase with respect to the common electrode distortion voltage. The offset voltage is generated at a capacitance ratio of the liquid crystal capacitor to the storage capacitor. The offset voltage generator for outputting the offset voltage increases a rate of charge of the storage capacitor based on the common electrode distortion voltage.

[0012] An apparatus for driving a liquid crystal display is provided, which includes a liquid crystal display panel that has a switching element formed in an area adjacent a gate line and a data line and is connected to the gate line and the data line, a liquid crystal capacitor for providing current to the switching element for controlling an image signal based on a pixel voltage in proportion to a common electrode voltage and a voltage potential of the data line, and a storage capacitor for accumulating the data voltage when the switching element is turned on, and applying the accumulated data voltage to the liquid crystal capacitor when the switching

element is turned off. The apparatus includes: a distortion detector for detecting a distortion of the common electrode voltage applied to the liquid crystal capacitor and outputting a common electrode distortion voltage to the offset voltage generator; and an offset voltage generator for increasing a rate of charge of the storage capacitor based on the common electrode distortion voltage and outputting an offset voltage for overcharging the storage capacitor.

[0013] A method for driving a liquid crystal display is also provided, which includes a switching element connected to a gate line and a data line, a liquid crystal capacitor passing a light based on a pixel voltage in proportion to a common electrode voltage and a data voltage according to a turn-on operation of the switching element, and a storage capacitor having one terminal thereof connected to one terminal of the liquid crystal capacitor for accumulating the data voltage when the switching element is turned on, and which applies the accumulated data voltage to the liquid crystal capacitor when the switching element is turned off. The method includes the steps of: applying the data voltage to the data line; applying a scanning signal to the gate line for accumulating the data voltage applied to the data line via the terminals of the liquid crystal capacitor and the storage capacitor; applying the common electrode voltage to another terminal of the liquid crystal capacitor; detecting the common electrode voltage and outputting a common electrode distortion voltage proportional to a distorted portion of the common electrode voltage; generating an offset voltage for offsetting the distortion of the common electrode distortion voltage; and applying the offset voltage to the terminal of the storage capacitor.

[0014] According to an embodiment of the present invention, the offset voltage is in antiphase with respect to the common electrode distortion voltage. The offset voltage is proportional to a capacitance ratio of the liquid crystal capacitor to the storage capacitor.

BRIEF DESCRIPTION OF THE DRAWINGS

[0015] The above objects and advantages of the present invention will become more apparent by describing in detail preferred embodiments thereof with reference to the attached drawings in which:

[0016] **FIG. 1** is a waveform diagram of signals having crosstalk;

[0017] **FIG. 2** illustrates a block diagram of a liquid crystal display according to an embodiment of the present invention;

[0018] **FIG. 3** illustrates waveform diagrams of a common electrode voltage generally applied and an offset voltage applied according to the present invention, respectively;

[0019] **FIG. 4** is an equivalent circuit of a pixel in a liquid crystal display panel according to the present invention;

[0020] **FIG. 5A** illustrates a distortion detector usable in the system of **FIG. 2**;

[0021] **FIG. 5B** is another distortion detector usable in the system of **FIG. 2**;

[0022] **FIG. 6A** illustrates an offset voltage generator shown in **FIG. 2**;

[0023] **FIG. 6B** is an equivalent circuit of the offset voltage generator in the liquid crystal display according to an embodiment of the present invention; and

[0024] **FIG. 7** is a waveform diagram for the results of the simulation of the circuit shown in **FIG. 6B**.

DETAILED DESCRIPTION OF PREFERRED EMBODIMENTS

[0025] The features and advantages of the present invention will become more apparent from the detailed description of preferred embodiments with reference to the accompanying drawings, like reference numerals are used for description of like or equivalent parts or portions for simplicity of illustration and explanation.

[0026] **FIG. 2** illustrates a block diagram of a liquid crystal display according to an embodiment of the present invention. **FIG. 3** illustrates waveform diagrams of a generally applied common electrode voltage and an offset voltage applied according to an embodiment of the present invention, respectively.

[0027] Referring to **FIG. 2**, the liquid crystal display according to an embodiment of the present invention includes a driving voltage generator **100**, a distortion detector **200**, an offset voltage generator **300**, a liquid crystal display panel **400**, a data driver for supplying an image signal to the liquid crystal display panel **400**, and a gate driver for sequentially outputting a scanning signal to the liquid crystal display panel **400**. The driving voltage generator **100** outputs a common electrode voltage V_{com} as a reference of the data voltage difference to the distortion detector **200**, the offset voltage generator **300**, and the liquid crystal display panel **400**. The distortion detector **200** receives the common electrode voltage V_{com} from the driving voltage generator **100** to detect a distortion level of the common electrode voltage and sends a common electrode distortion voltage V_{comd} to the offset voltage generator **300**. The offset voltage generator **300** receives the common electrode voltage V_{com} from the driving voltage generator **100** and the common electrode distortion voltage V_{comd} from the distortion detector **200**, and sends an offset voltage V_{cstd} to the liquid crystal display panel **400**. The liquid crystal display panel **400**, including a plurality of pixels in a matrix format, receives the common electrode voltage V_{com} from the driving voltage generator **100** and the offset voltage V_{cstd} from the offset voltage generator **300**. The common electrode distortion voltage V_{comd} is applied to a common electrode line (not shown) of the liquid crystal display panel as shown in **FIG. 3(a)**, the offset voltage V_{cstd} is output to the common electrode line to compensate for a deficient charging rate of a liquid crystal capacitor (not shown in **FIG. 3**) as shown in **FIG. 3(b)**, thereby reducing crosstalk.

[0028] Now, a detailed description will be given to the common electrode voltage V_{com} generally applied to the liquid crystal display panel **400**, and to the offset voltage V_{cstd} applied to compensate for the distortion of the common electrode voltage V_{com} according to the present invention.

[0029] **FIG. 4** illustrates the common electrode voltage and the offset voltage applied to a pixel of the liquid crystal panel according to an embodiment of the present invention. The illustrative pixel of the liquid crystal display panel **400**

is formed in the area surrounded by a gate line and a data line, and includes a switching element TFT, a liquid crystal capacitor C_{LC} , and a storage capacitor C_{st} . The switching element TFT is connected to the gate line and the data line. The liquid crystal capacitor C_{LC} charges and discharges a pixel voltage that is proportional to the common electrode voltage V_{com} and the voltage from the data line to turn on/off the switching element TFT to thereby control the amount of light to output. The storage capacitor C_{st} accumulates the data voltage when the switching element TFT is turned on, and applies the accumulated data voltage to the liquid crystal capacitor C_{LC} when the switching element is turned off, thereby forming a picture.

[0030] It is preferred that the common electrode voltage V_{com} is used as a reference of the positive data voltage and the negative data voltage applied to the liquid crystal capacitor C_{LC} . In practice, the common electrode voltage V_{com} is distorted by a parasitic capacitor C_{par} that exists between the data line and the liquid crystal capacitor C_{LC} . The parasitic capacitor C_{par} causes a common electrode distortion voltage V_{comd} to be applied to the liquid crystal capacitor C_{LC} . The existence of the common electrode distortion voltage V_{comd} reduces the pixel charging rate in proportion to the difference between an input gray voltage at the data line and the common electrode voltage, and thereby causes crosstalk. According to an embodiment of the present invention, a predetermined offset voltage V_{cstd} is supplied to the storage capacitor C_{st} to compensate for the common electrode voltage distortion voltage V_{comd} . Preferably, the storage capacitor C_{st} is overcharged to compensate for a deficient charging rate of the liquid crystal capacitor C_{LC} caused by the common electrode voltage distortion voltage V_{comd} . As a result, a difference in charging rate between the two capacitors C_{LC} and C_{st} for a pixel offsets the deficient charging rate of the liquid crystal capacitor C_{LC} . Preferably, the voltage applied to the data line which is a representation of gray and the resulting distortion level of the common electrode voltage V_{com} are out-of-phase (antiphase). The combined voltage is applied to the storage capacitor C_{st} . The combined distortion voltage applied to the storage capacitor C_{st} is dependent on the capacitance ratio of the liquid crystal capacitor C_{LC} to the storage capacitor C_{st} . For example, when the capacitance ratio of the liquid crystal capacitor C_{LC} to the storage capacitor C_{st} is 1:1, an offset voltage V_{cstd} having the same level as the common electrode distortion voltage V_{comd} and being in antiphase with respect to the common electrode distortion voltage V_{comd} is applied to the storage capacitor C_{st} . When the capacitance ratio of the liquid crystal capacitor C_{LC} and the storage capacitor C_{st} is 2:1, an offset voltage V_{cstd} of 0.5 of the common electrode distortion voltage V_{comd} and being in antiphase with respect to the common electrode distortion voltage V_{comd} is applied to the storage capacitor C_{st} .

[0031] Now, the effect of the present invention thus obtained will be described in further detail.

[0032] Assuming an ideal state in which there is no distortion of the common electrode voltage V_{com} , the charge Q_0 charged in one pixel is given by Equation 1:

$$Q_0 = C_{LC} \cdot (V_s - V_{com}) + C_{st} \cdot (V_s - V_{cst}) \quad [\text{Equation 1}]$$

where C_{LC} is the capacitance of the liquid crystal capacitor, V_s is a data voltage applied to the data line during one hour (or one horizontal hour), V_{com} is the common electrode

voltage without distortion, C_{st} is the capacitance of the storage capacitor, and V_{cst} is a voltage applied to the storage capacitor C_{st} .

[0033] If distortion of the common electrode voltage occurs, the charge Q_1 accumulated in one pixel is given by Equation 2:

$$Q_1 = C_{LC} \cdot (V_s - V_{comd}) + C_{st} \cdot (V_s - V_{cst}) \quad [\text{Equation 2}]$$

where V_{comd} is the common electrode distortion voltage during one hour (or one horizontal hour)

[0034] Accordingly, the difference between the charge Q_0 in the pixel without distortion and the charge Q_1 in the pixel with distortion can be calculated based on the Equations 1 and 2, and it is given by Equation 3:

$$Q_0 - Q_1 = C_{LC} \cdot (V_{comd} - V_{com}) \quad [\text{Equation 3}]$$

[0035] As shown in Equation 3, there occurs crosstalk in proportion to the difference in charging rates.

[0036] However, when the offset voltage V_{cstd} is applied to the storage capacitor C_{st} instead of the common electrode distortion voltage V_{cst} according to the present invention, the charge Q_2 accumulated in one pixel is given by Equation 4:

$$Q_2 = C_{LC} \cdot (V_s - V_{comd}) + C_{st} \cdot (V_s - V_{cstd}) \quad [\text{Equation 4}]$$

where

$$V_{cstd} = \frac{C_{LC}}{C_{st}} \cdot (V_{comd} - V_{com}) + V_{cst}$$

Accordingly, the difference between the charge Q_0 in the pixel without distortion and the charge Q_2 of the present invention is given by Equation 5:

$$Q_0 - Q_2 = C_{LC} \cdot (V_{comd} - V_{com}) + C_{st} \cdot (V_{cstd} - V_{cst}) = 0 \quad [\text{Equation 5}]$$

[0037] As shown in Equation 5, the net charge is zero. Advantageously, the crosstalk which occurs in the common electrode voltage is offset and no distortion is seen at the liquid crystal capacitor C_{st} .

[0038] FIGS. 5A and 5B illustrate examples of the distortion detector according to a preferred embodiment of the present invention.

[0039] Referring to FIGS. 2 and 5A, before the common electrode voltage V_{com} generated from the driving voltage generator 100 is applied to the liquid crystal display panel 400, a defined detection resistor R_D is provided to detect a distortion level of the common electrode voltage V_{com} with the potential difference between both terminals of the detection resistor R_D . And the defined detection resistor R_D outputs the common electrode distortion voltage V_{comd} to the offset voltage generator 300.

[0040] Referring to FIGS. 2 and 5B, after the common electrode voltage V_{com} generated from the driving voltage generator 100 is applied to the liquid crystal display panel 400, a defined detection resistor R_D is provided as an internal resistor of the liquid crystal display panel 400 to detect a distortion level of the common electrode voltage V_{com} with the potential difference between both terminals of the detection resistor R_D . And a defined detection resistor R_D outputs the common electrode distortion voltage V_{comd} to the offset voltage generator 300.

[0041] FIG. 6A illustrates an offset voltage generator 300 according to an embodiment of the present invention, which includes a first OP amplifier OP₁ driven by a power voltage AV_{DD}, first, second, and third resistors R₁, R₂, and R₃, and a first capacitor C₁. The first OP amplifier OP₁ preferably has a non-inverting input connected to the common electrode voltage V_{com} and an inverting input connected to the first resistor R₁ and the second resistor R₂ connected in parallel with the first resistor R₁. The first resistor R₁ serves as a feedback resistor connected to an output of the first OP amplifier OP₁. The second resistor R₂ is connected to the common electrode distortion voltage V_{comd}.

[0042] In operation, the common electrode distortion voltage V_{comd} is fed into the inverting input of the first OP amplifier OP₁ via the second resistor R₂, and an output voltage V_{out} is output at the output of the first OP amplifier OP₁. A DC component of the output voltage V_{out} is removed via the first capacitor C₁ and only an AC component of the output voltage V_{out} is transferred, so that the offset voltage V_{csd} is output to the other terminal of the storage capacitor C_{st} (in FIG. 4).

[0043] Next, the operation of the offset voltage generator shown in FIG. 6A will be described by way of the following equations.

[0044] The characteristic of the first OP amplifier OP₁ shown in FIG. 6A can be defined as Equation 6:

$$V_{out} = -\left(\frac{R_1}{R_2}\right) \cdot V_{comd} + \left(1 + \frac{R_1}{R_2}\right) \cdot V_{com} \quad [\text{Equation 6}]$$

[0045] The common electrode distortion voltage V_{comd}, which includes AC and DC components, can be defined as Equation 7:

$$V_{comd} = V_{comd}(AC) + V_{comd}(DC) = V_{comd}(AC) + V_{com} \quad [\text{Equation 7}]$$

[0046] Accordingly, Equation 6 can be rewritten based on Equation 7 and gives the output voltage V_{out} from the first OP amplifier OP₁ as Equation 8:

$$V_{out} = -\left(\frac{R_1}{R_2}\right) [V_{comd}(AC) + V_{com}] + \left(1 + \frac{R_1}{R_2}\right) V_{com} \quad [\text{Equation 8}]$$

$$V_{com} = -\left(\frac{R_1}{R_2}\right) \cdot V_{comd}(AC) + V_{com}$$

where the term

$$-\frac{R_1}{R_2} \cdot V_{comd}(AC)$$

is the AC component and the term “V_{com}” is the DC component. But, since the output voltage V_{out} passes through the first capacitor C₁, only the AC component, i.e.,

$$-\frac{R_1}{R_2} \cdot V_{comd}(AC)$$

is transferred to a level shift circuit (to the first capacitor C₁) as the charging voltage V_{csd} of the storage capacitor caused by the first capacitor C₁ and the third resistor R₃. One skilled in the art can really appreciate that when applying the charging voltage V_{csd} of the storage capacitor having the same level as the common electrode voltage V_{com} to the storage capacitor C_{st} (in FIG. 4), the output voltage V_{out} can be directly applied to the other terminal of the storage capacitor C_{st} (in FIG. 4) without filtering out the DC component.

[0047] An equivalent circuit of the circuit of FIG. 6A is shown in FIG. 6B. Referring to FIG. 6B, a data voltage V_{src} in the liquid crystal display panel 400 is an output voltage of the data driver (in FIG. 2) applied to the data line (in FIG. 4), and it is coupled to the common electrode voltage V_{com} via a parasitic capacitor C_{com}. This causes a distortion of the common electrode voltage V_{com}, which is the DC component, as the common electrode distortion voltage V_{comd}. The common electrode distortion voltage V_{comd} is inverted and amplified at a predetermined ratio R₁/R₂ and only the distorted AC component is transferred to the charging voltage V_{csd} of the storage capacitor via the first capacitor C₁. The role of the first capacitor C₁ is the same as FIG. 6A. In this way, the common electrode distortion voltage V_{csd} is added to the offset voltage V_{csd} based on the charging voltage V_{csd} of the storage capacitor to generate a crosstalk-compensating voltage.

[0048] FIG. 7 is a waveform diagram showing simulation results of the circuit of FIG. 6B in a case wherein the first resistor R₁ is equal to the second resistor R₂. That is, the capacitance of the liquid crystal capacitor C_{LC} (in FIG. 4) is assumed to be equal to that of the storage capacitor C_{st} (in FIG. 4).

[0049] Referring to FIGS. 6B and 7, the common electrode voltage V_{com} coupled to the waveform of the data voltage V_{src} applied to the data line (in FIG. 4) is distorted, and there occurs a waveform of the offset voltage V_{csd} that is in antiphase with respect to the AC component of the common electrode distortion voltage V_{comd}, the offset voltage V_{csd} is applied to the storage capacitor C_{st}.

[0050] If the capacitance of the liquid crystal capacitor C_{LC} is set to be different from that of the storage capacitor C_{st}, an optimum compensating waveform can be formed by setting the ratio of the first resistor R₁ to the second resistor R₂ as the capacitance ratio of the liquid crystal capacitor C_{LC} to the storage capacitor C_{st}.

[0051] As described above, the present invention enables a constant charging rate of the pixel voltage even with a different distortion level of the common electrode voltage applied to the liquid crystal capacitor. In particular, the present invention overcharges the storage capacitor to compensate for a deficient rate of charge of the liquid crystal capacitor caused by a distortion of the common electrode voltage. Preferably, the charging rate difference between the liquid crystal capacitor and the storage capacitor compensates for the lack of the charging rate of the liquid crystal

capacitor in the pixel. Accordingly, a constant rate of charge of the pixel voltage can be maintained despite variations in distortion level of the common electrode voltage, to thereby preventing crosstalk.

[0052] While this invention has been described in connection with what is presently considered to be the most practical and preferred embodiment, it is to be understood that the invention is not limited to the disclosed embodiments, but is intended to cover modifications and equivalent arrangements within the spirit and scope of the appended claims.

What is claimed is:

1. A liquid crystal display, comprising:
 - a data driver for outputting an image signal;
 - a gate driver for sequentially outputting a scanning signal;
 - a liquid crystal display panel coupled to the data and gate drivers and including a plurality of pixels, a plurality of switching elements, a common electrode, and a storage capacitor;
 - a distortion detector for detecting a voltage applied to the common electrode and outputting a common electrode distortion voltage in response to the detected voltage; and
 - an offset voltage generator for outputting an offset voltage based on the common electrode distortion voltage to change an amount of charging of the storage capacitor, wherein the offset voltage is out of phase with respect to the common electrode distortion voltage.
2. The liquid crystal display of claim 1, wherein a difference phase between the offset voltage and the common electrode distortion voltage is about 180°.
3. The liquid crystal display of 2, wherein the offset voltage generator comprises:
 - an OP amplifier for receiving the common electrode voltage at its non-inverting terminal and the common electrode distortion voltage at its inverting terminal and outputting an output voltage at its output terminal; and
 - a DC component remover for removing a DC component of the output voltage and outputting an AC offset voltage.
4. The liquid crystal display of claim 1, wherein the distortion detector comprises a detection resistor to detect the common electrode voltage and outputting the common electrode distortion voltage.

5. The liquid crystal display of claim 1, wherein the distortion detector detects a voltage across two terminals of the detection resistor.

6. The liquid crystal display of claim 1, wherein the offset voltage generator receives the common electrode voltage at its non-inverting terminal and the common electrode distortion voltage at its inverting terminal, and outputting the offset voltage at its output terminal.

7. The liquid crystal display of claim 1, wherein the offset voltage generator increases an amount of charging of the storage capacitor based on the common electrode distortion voltage.

8. An apparatus for driving a liquid crystal display, comprising:

- a distortion detector for detecting a voltage applied to the common electrode and outputting a common electrode distortion voltage in response to the detected voltage; and

- an offset voltage generator for outputting an offset voltage based on the common electrode distortion voltage to change an amount of charging of the storage capacitor,

wherein the offset voltage is out of phase with respect to the common electrode distortion voltage.

9. The apparatus of claim 8, wherein a phase difference between the offset voltage and the common electrode distortion voltage is about 180°.

10. The apparatus of claim 9, wherein the offset voltage generator comprises:

- an OP amplifier for receiving the common electrode voltage at its non-inverting terminal and the common electrode distortion voltage at its inverting terminal and outputting an output voltage at its output terminal; and

- a DC component remover for removing a DC component of the output voltage and outputting an AC offset voltage.

11. The apparatus of claim 8, wherein the distortion detector comprises a detection resistor for detecting the common electrode voltage and outputting the common electrode distortion voltage.

12. The apparatus of claim 8, wherein the offset voltage generator receives the common electrode voltage at its non-inverting terminal and the common electrode distortion voltage at its inverting terminal, and outputs the offset voltage at its output terminal.

* * * * *

专利名称(译)	液晶显示装置及其驱动方法		
公开(公告)号	US20060092112A1	公开(公告)日	2006-05-04
申请号	US11/300148	申请日	2005-12-14
[标]申请(专利权)人(译)	三星电子株式会社		
申请(专利权)人(译)	SAMSUNG ELECTRONICS CO. , LTD.		
当前申请(专利权)人(译)	三星DISPLAY CO. , LTD.		
[标]发明人	MOON SEUNG HWAN		
发明人	MOON, SEUNG-HWAN		
IPC分类号	G09G3/36 G02F1/133 G09G3/20		
CPC分类号	G09G3/3655 G09G2300/0876 G09G2310/06 G09G2320/0204 G09G2320/0209		
优先权	1020010059319 2001-09-25 KR		
其他公开文献	US7619603		
外部链接	Espacenet USPTO		

摘要(译)

提供一种液晶显示器。该显示器包括：用于输出图像信号的数据驱动器；用于顺序输出扫描信号的栅极驱动器；液晶面板，包括用于响应扫描信号控制图像信号的开关元件，由图像信号和公共电极电压之间的电压差驱动的液晶电容器，以及用于累积图像信号电荷的存储电容器当开关元件接通时，当开关元件断开时，将累积的图像信号施加到液晶电容器；失真检测器，用于检测施加到液晶电容器的公共电极电压并输出公共电极失真电压；偏移电压发生器，用于输出偏移电压，以基于公共电极畸变电压增加存储电容器的充电速率。

