



US 20050018115A1

(19) **United States**

(12) **Patent Application Publication** (10) **Pub. No.: US 2005/0018115 A1**

Liao et al.

(43) **Pub. Date: Jan. 27, 2005**

(54) **TRANSFLECTIVE DISPLAY DEVICE WITH DIFFERENT PRETILT ANGLES AND FABRICATION METHOD FOR THEREOF**

(30) **Foreign Application Priority Data**

Dec. 17, 2002 (TW)..... TW91136410

(75) Inventors: **Chih-Chang Liao**, Tainan (TW);
Yichun Wong, Tainan (TW);
Kang-Hung Liu, Hsinchu (TW);
Yang-Yi Fan, Taichung (TW)

Publication Classification

(51) **Int. Cl.⁷** **G02F 1/1335**

(52) **U.S. Cl.** **349/114**

Correspondence Address:
QUINTERO LAW OFFICE
1617 BROADWAY, 3RD FLOOR
SANTA MONICA, CA 90404 (US)

(57) **ABSTRACT**

A transflective display device has a single cell gap in which a liquid crystal molecule has at least two pretilt angles. A transparent electrode is formed on the inner surface of the lower substrate, and a reflective electrode is formed on a portion of the transparent electrode. Thus, creating a reflective region over the reflective electrode, and a transmissive region over the transparent electrode which is not covered by the reflective electrode. Using a photo-alignment process to form at least two alignment domains on each of the two alignment layers sandwiching a liquid crystal layer, the pretilt angle of the liquid crystal molecule in the reflective region is different from the pretilt angle of the liquid crystal molecule in the transmissive region, the reflective region and the transmissive region have the same phase retardation, and the light path passing through the reflective region is twice the light path passing through the transmissive region.

(73) Assignee: **INDUSTRIAL TECHNOLOGY RESEARCH INSTITUTE, HSINCHU (TW)**

(21) Appl. No.: **10/923,586**

(22) Filed: **Aug. 20, 2004**

Related U.S. Application Data

(62) Division of application No. 10/437,495, filed on May 14, 2003.

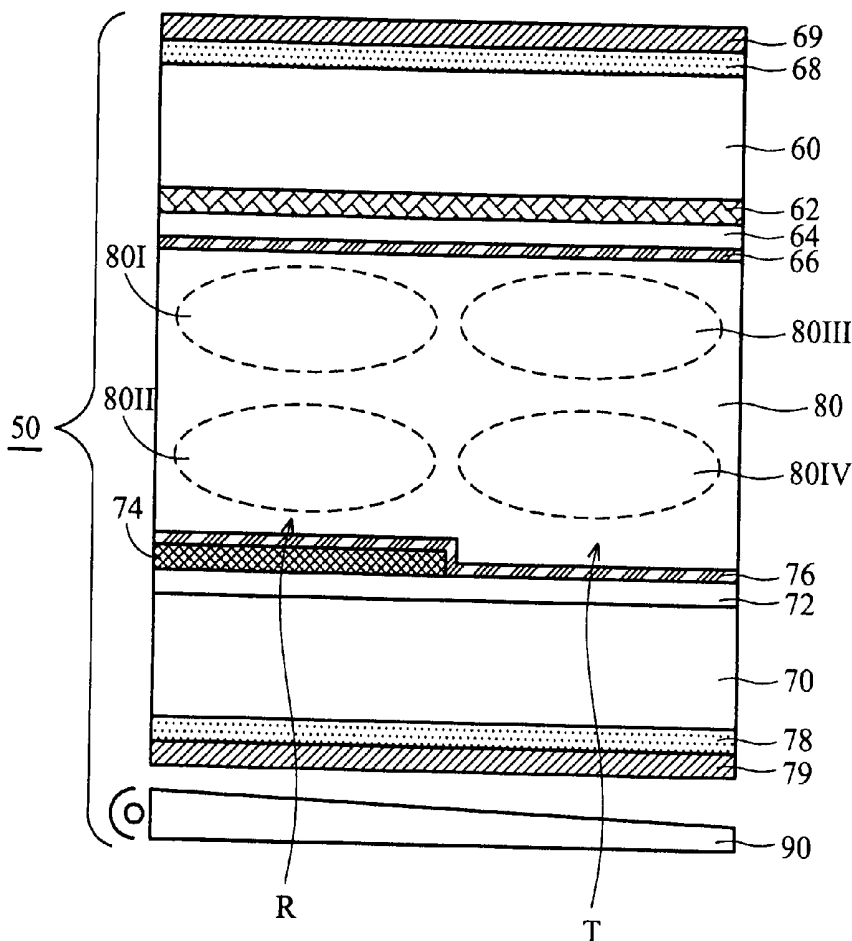

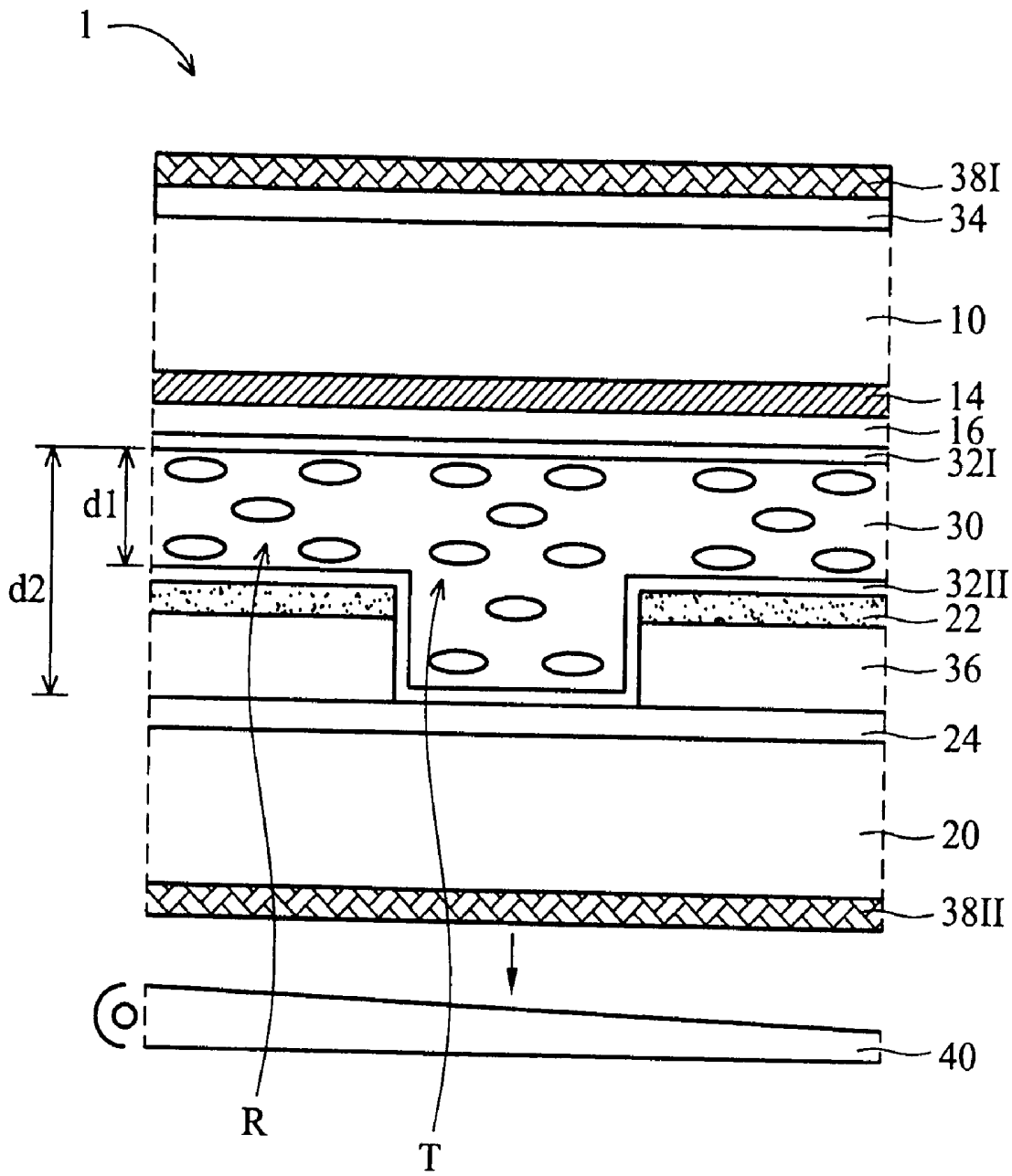

FIG. 1B (PRIOR ART)

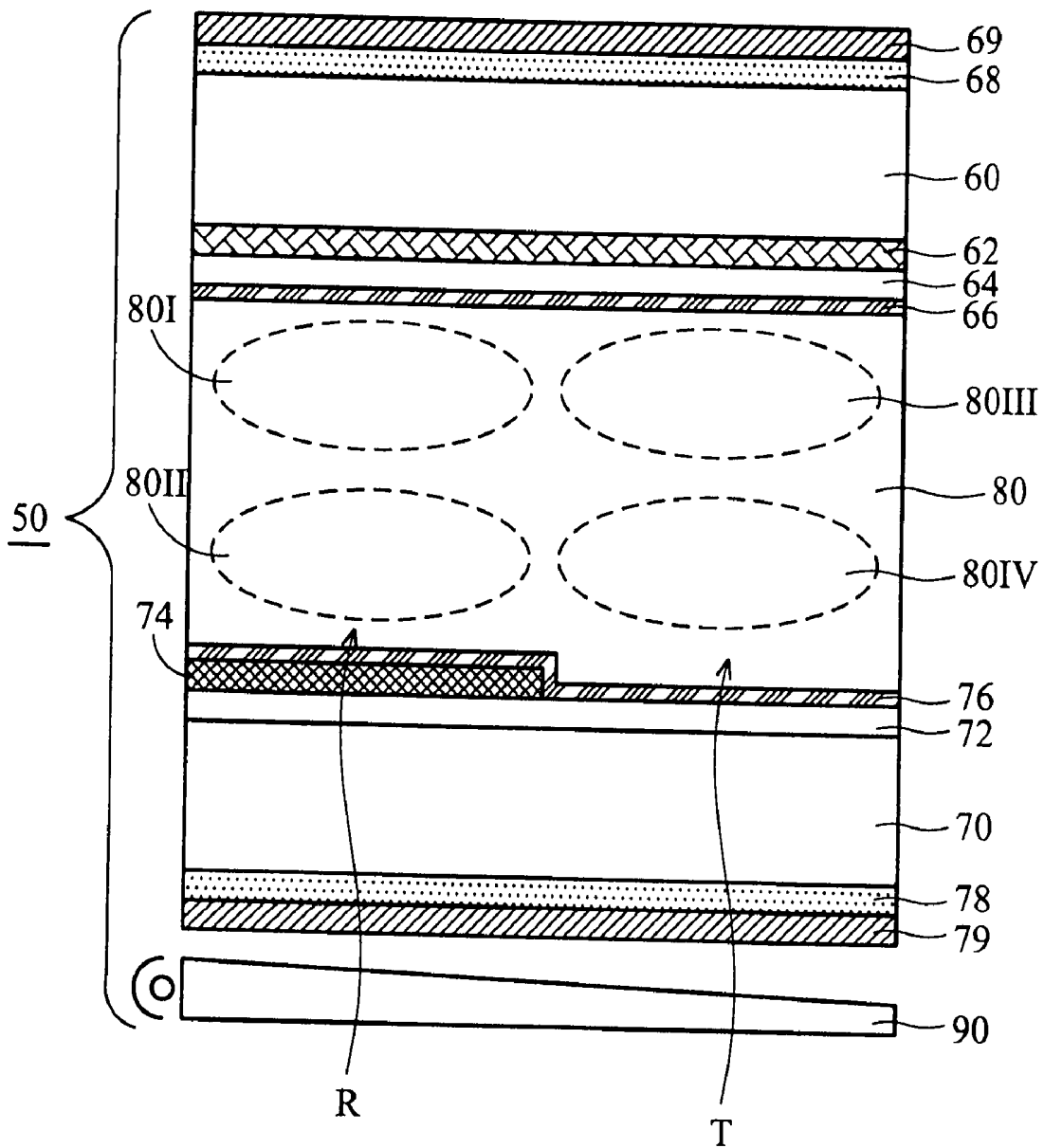

FIG. 2

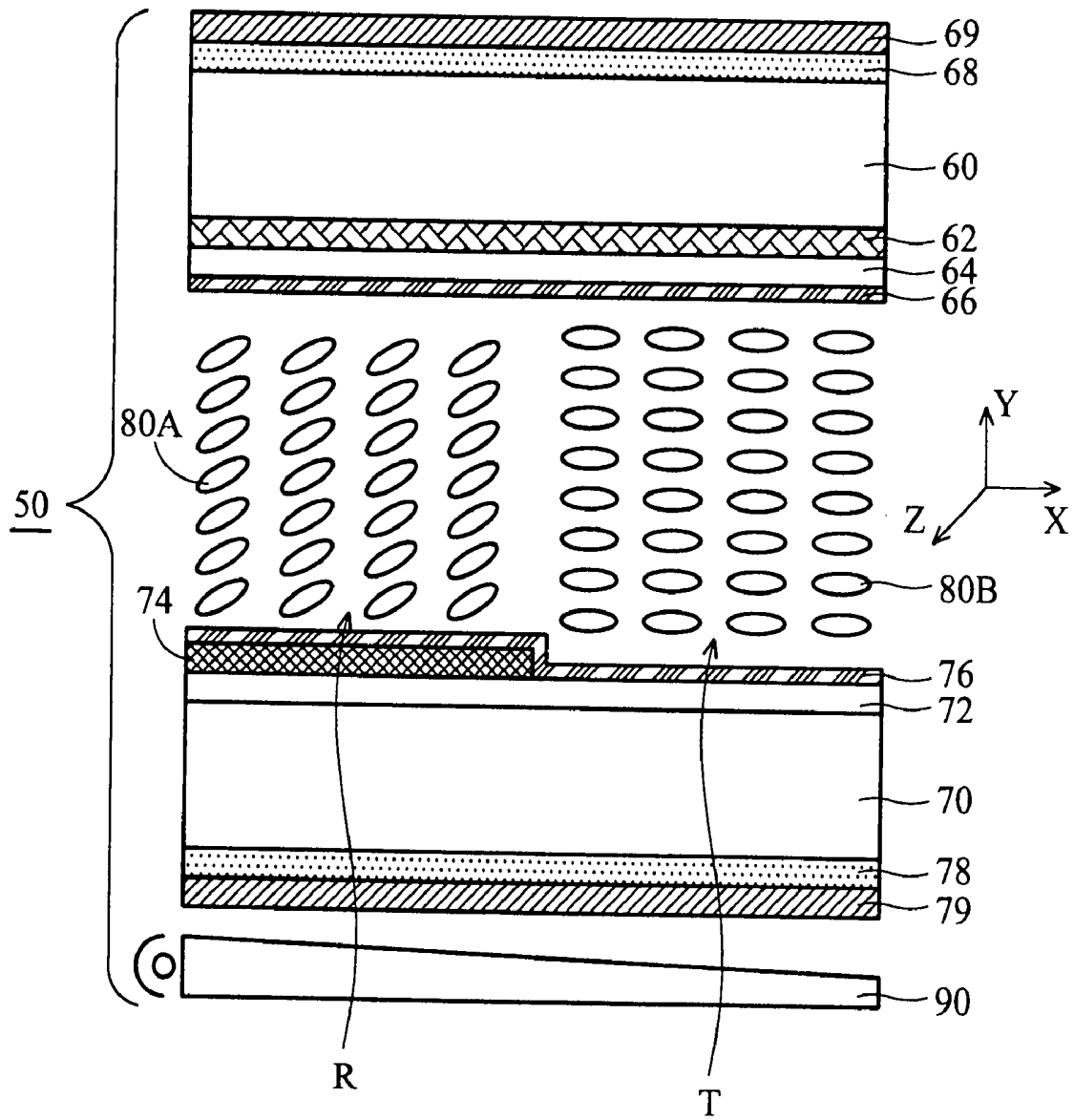

FIG. 3A

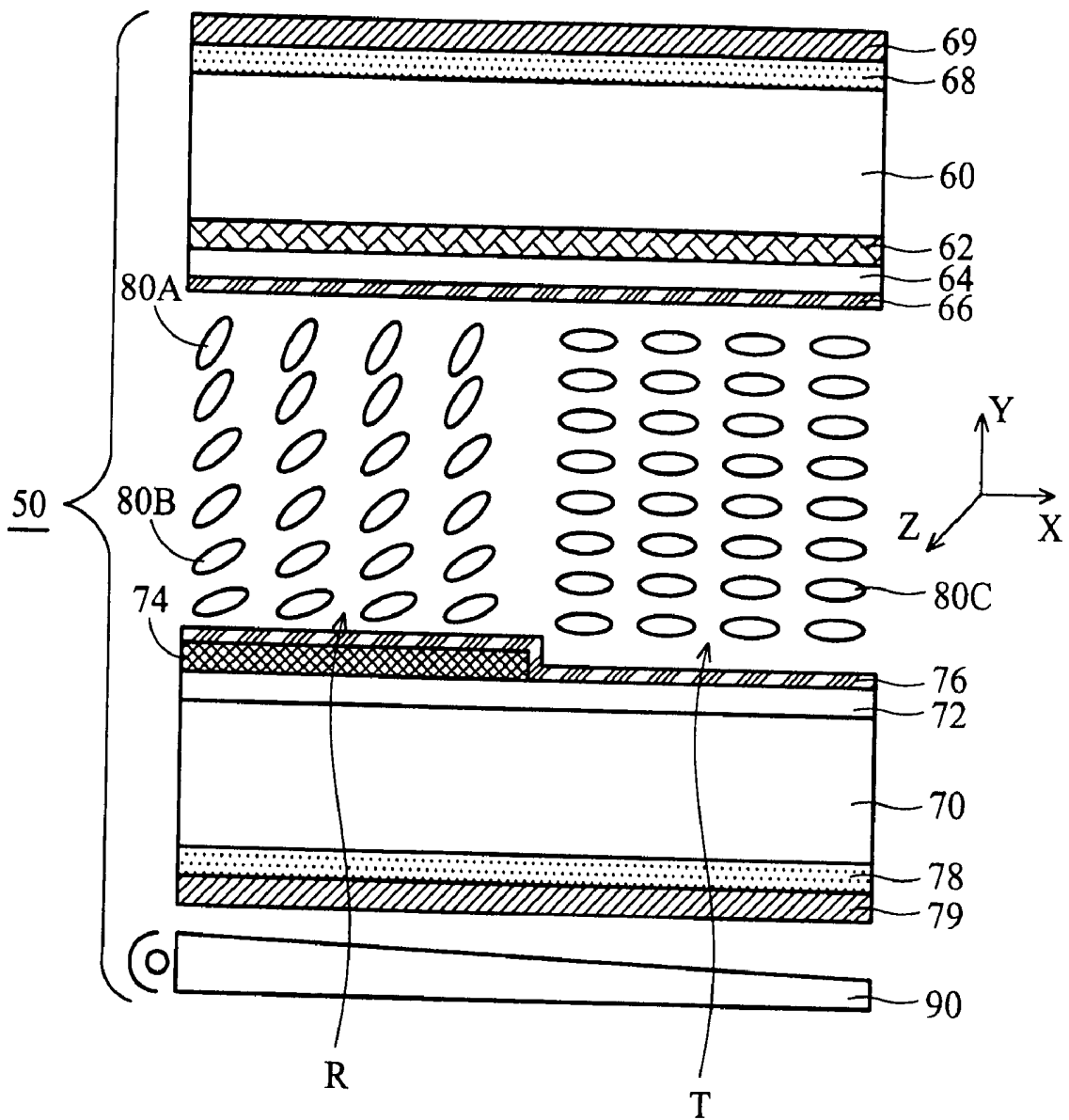

FIG. 3B

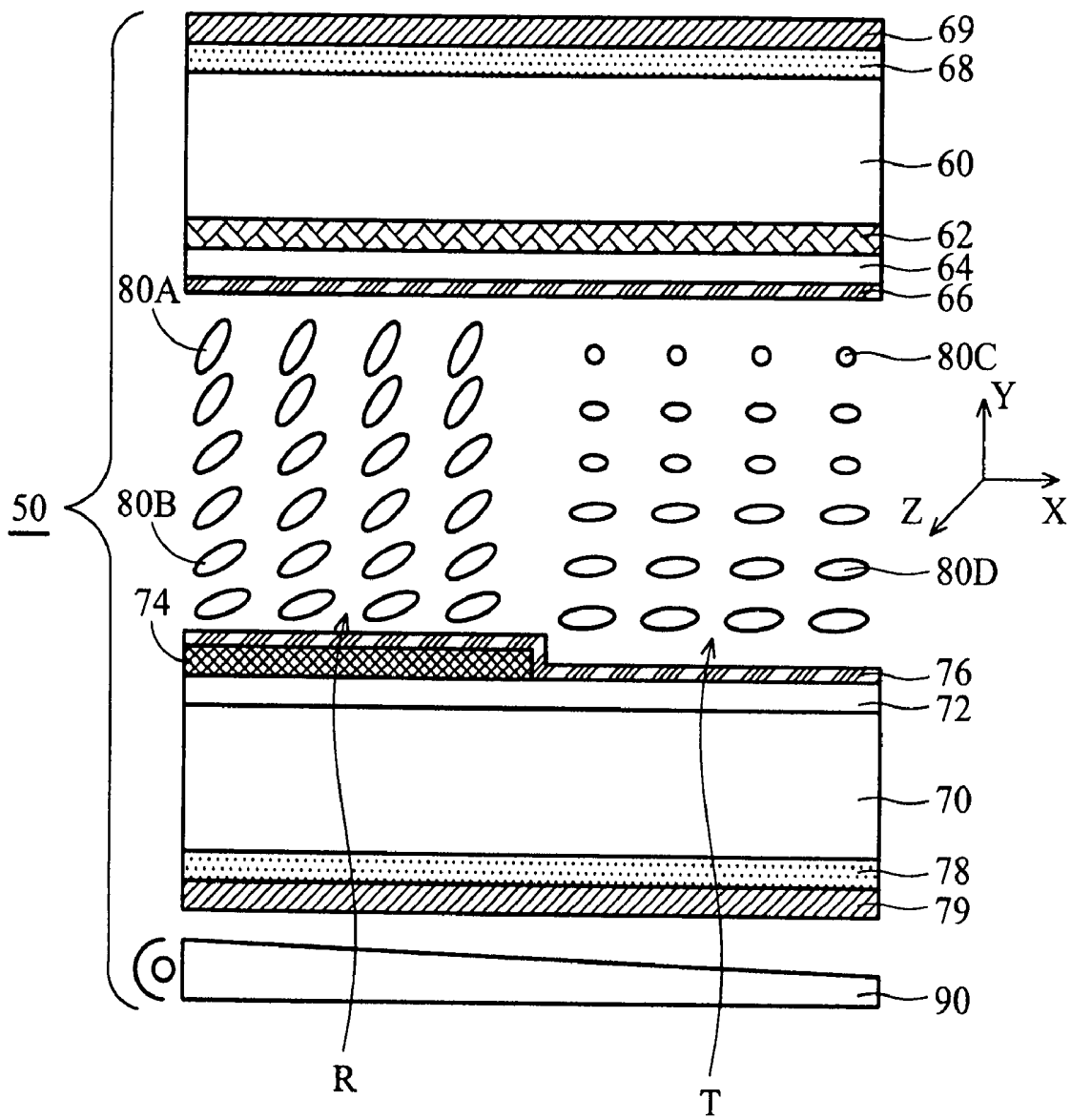

FIG. 3C

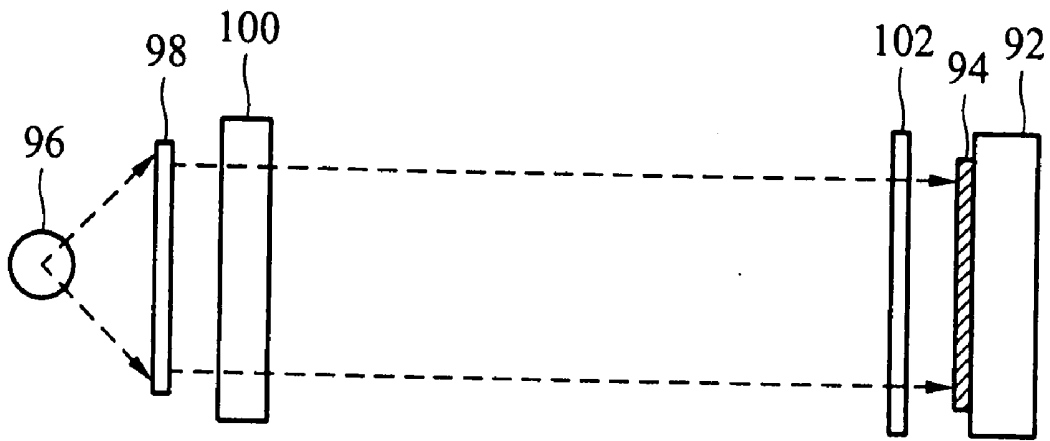

FIG. 4

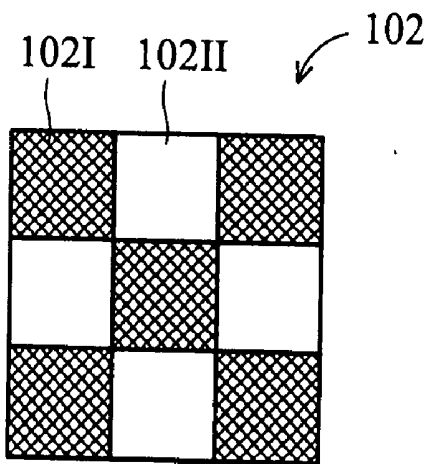

FIG. 5A

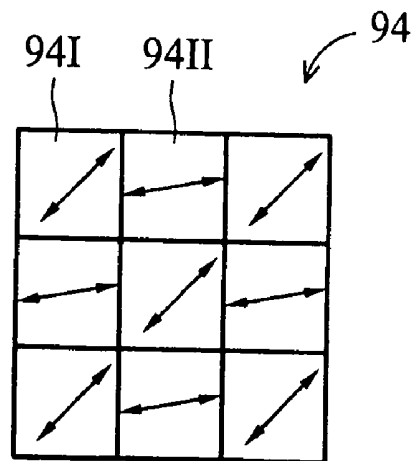

FIG. 5B

**TRANSFLECTIVE DISPLAY DEVICE WITH
DIFFERENT PRETILT ANGLES AND
FABRICATION METHOD FOR THEREOF**

BACKGROUND OF THE INVENTION

[0001] 1. Field of the Invention

[0002] The invention relates to a transfective display device, and more particularly to a transfective display device that employs a photo-alignment process to make liquid crystal molecules have at least two pretilt angles within a single cell gap.

[0003] 2. Description of the Related Art

[0004] Liquid crystal display (LCD) devices are usually classified into transmission type and reflection type according to the difference in their display light source. The transmission type LCD device uses a back light module, in which the light is incident to an LC layer and is absorbed or passes through the LC layer, thus disadvantages of faded color and reduced contrast ratio are found under a natural light source or an exterior artificial light source. On the contrary, the reflection type LCD device uses an ambient light incident from an exterior light source, resulting in superior performance and high contrast ratio under outdoor sunlight. Also, because of its low power consumption, the reflection type LCD device is focused on portable display products. However, the reflection type LCD device is useless when the weather or exterior light source is dark, and it is comparatively difficult to achieve high resolution for a full color display.

[0005] Accordingly, transfective LCD devices have developed to compensate for the reflection type LCD device and possess the advantages found in the transmission type LCD device and the reflection type LCD device. The transfective LCD device can use well known active driving processes, such as amorphous silicon thin film transistor (a-Si TFT) or low temperature polysilicon (LTPS) TFT, and is applied to information products of low power consumption. U.S. patent application Publication No.2002/0003596A1 discloses a transfective LCD device that designs an LC cell as dual cell gaps and has a retardation film.

[0006] FIG. 1A is an exploded perspective view illustrating a typical transfective LCD device. FIG. 1B is a cross-sectional view illustrating dual cell gaps of the transfective LCD device shown in FIG. 1A.

[0007] In FIG. 1A, a transfective LCD device 1 includes an upper substrate 10 and a lower substrate 20 opposing each other, and an LC layer 30 is interposed therebetween. For the upper substrate 10, on an inner surface opposing the lower substrate 20, a black matrix 12 and a color filter layer 14 that includes a plurality of red (R), green (G), and blue (B) color elements are formed, and a common electrode 16 is formed to cover the color filter layer 14 and the black matrix 12.

[0008] For the lower substrate 20, on an inner surface opposing the upper substrate 10, a plurality of crossing gate lines 26 and data lines 28 are formed to define a plurality of pixel regions P arranged in a matrix and corresponding to the color filter layer 14, and a plurality of TFTs, serving as switching devices, is located near each cross point of the adjacent gate line 26 and data line 28. Also, a plurality of

reflective electrodes 22 and a plurality of transparent electrodes 24 are formed on the pixel areas P, respectively. Each of the reflective electrodes 22 has a through hole to expose a transparent electrode 24 disposed there below. Thus, the exposed portion of the transparent electrode 24 serves as a transmissive region T, and the electrode portion outside the through hole serves as a reflective region R.

[0009] In FIG. 1B, the lower substrate 20 comprises a protection layer 36 sandwiched between the reflective electrode 22 and the transparent electrode 24, and the through hole passes through the reflective layer 22 and the protection layer 36 to define the transmissive region T and the reflective region R. Furthermore, an upper alignment layer 32I is formed on the common electrode 16, a lower alignment layer 32II is formed on the reflective electrode 22 and exposed portion of the transparent electrode 24. A half wave plate (HWP) 34 and an upper polarizer 38I are sequentially disposed on the exterior surface of the upper substrate 10, and a lower polarizer 38II and a back light 40 are disposed on the exterior surface of the lower substrate 20. The HWP 34 is employed to involve a phase difference of $\lambda/2$ for incident lights.

[0010] Accordingly, in the pixel area P, the LC layer 30 has a first cell gap d_1 over the reflective electrode 22 within the reflective region R, and a second cell gap d_2 over the transparent electrode 24 within the transmissive region T. The second cell gap d_2 is twice beneficial as the first cell gap d_1 . Thus, a light achieves a phase difference of $\lambda/4$ after passing through the first cell gap d_1 , and a light achieves a phase difference of $\lambda/2$ after passing through the second cell gap d_2 . After passing through the HWP 34, the light achieves the additional phase difference of $\lambda/2$. The phase retardation in the transmissive region T is twice the phase retardation in the reflective region R.

[0011] Nevertheless, for patterning dual cell gaps in the LC layer 30, the process becomes more complicated. Also, the transfective film, such as the HWP 34, adhered to the exterior surface of the upper substrate 10 cannot achieve superior performance. Accordingly, a transfective LCD device based on a single cell gap design to achieve optical demands for both the transfective region and the reflective region is called for.

SUMMARY OF THE INVENTION

[0012] The present invention is a transfective display device based on a single cell gap design that employs a photo-alignment process to make liquid crystal molecules have at least two pretilt angles within the single cell gap, thus achieving optical demands for both the transfective region and the reflective region.

[0013] Accordingly, the present invention provides a transfective display device with different pretilt angles. An upper substrate and a lower substrate are opposed with each other and separated by a space, in which the space comprises a transmissive region and a reflective region. A first alignment layer is formed on the inner surface of the upper substrate. A transparent electrode is formed on the inner surface of the lower substrate, and a reflective electrode is formed on a portion of the transparent electrode. The reflective region is over the reflective electrode, and the transmissive region is over the transparent electrode which is not covered by the reflective electrode. A second alignment layer

is formed on the reflective electrode and the exposed surface of the transparent electrode. A liquid crystal layer is formed in the space between the upper substrate and the lower substrate and sandwiched between the first alignment layer and the second alignment layer to serve as a single cell gap. The liquid crystal layer comprises a first pretilt-angle region in the reflective region and adjacent to the first alignment layer, a second pretilt-angle region in the reflective region and adjacent to the second alignment layer, a third pretilt-angle region in the transmissive region and adjacent to the first alignment layer, and a fourth pretilt-angle region in the transmissive region and adjacent to the second alignment layer. The liquid crystal molecules have at least two pretilt angles in the first pretilt-angle region, the second pretilt-angle region, the third pretilt-angle region and the fourth pretilt-angle region.

[0014] Preferably, the pretilt angle of the liquid crystal molecule in the reflective region is different from the pretilt angle of the liquid crystal molecule in the transmissive region, the reflective region and the transmissive region have the same phase retardation, and the light path passing through the reflective region is twice the light path passing through the transmissive region.

DESCRIPTION OF THE DRAWINGS

[0015] For a better understanding of the present invention, reference is made to a detailed description to be read in conjunction with the accompanying drawings.

[0016] FIG. 1A is an exploded perspective view illustrating a typical transfective LCD device.

[0017] FIG. 1B is a cross-sectional view illustrating dual cell gaps of the transfective LCD device shown in FIG. 1A.

[0018] FIG. 2 is a cross-sectional view illustrating a transfective LCD device with different pretilt angles according to the present invention.

[0019] FIG. 3A is a cross-sectional view illustrating a transfective LCD device with a dual pretilt-angle structure according to the present invention.

[0020] FIG. 3B is a cross-sectional view illustrating a transfective LCD device with a triple pretilt-angle structure according to the present invention.

[0021] FIG. 3C is a cross-sectional view illustrating a transfective LCD device with a quadruple pretilt-angle structure according to the present invention.

[0022] FIG. 4 is a cross-sectional view illustrating a photo-alignment method.

[0023] FIG. 5A is a plane view of a pattern on a multi-domain photo mask of FIG. 4.

[0024] FIG. 5B is a plane view of a pattern on an alignment layer of FIG. 4.

DETAILED DESCRIPTION OF THE INVENTION

[0025] The present invention provides a transfective display device with a single cell gap design, in which liquid crystal molecules have different pretilt angles within the single cell gap. Due to the different pretilt angles in a transmissive region and a reflective region, the phase retardation of the transmissive region is identical to the phase retardation of the reflective region. One light path passing through the reflective region is twice the other light path passing through the transmissive region. In order to achieve the different pretilt angles in the liquid crystal layer, an alignment layer with a specific pattern can be provided by photo alignment, rubbing, ion beam or slanting deposition. The liquid crystal molecules are of dielectric anisotropic, twisted nematic (TN) or super twisted nematic (STN) type. Preferably, the combination of the alignment layer and the liquid crystal layer must be able to control the pretilt angle of the liquid, crystal molecules.

[0026] FIG. 2 is a cross-sectional view illustrating a transfective LCD device with different pretilt angles according to the present invention. A transfective LCD device 50 includes an upper substrate 60 and a lower substrate 70 that are opposed with each other, and an LC layer 80 is interposed therebetween. For the upper substrate 60, on an inner surface opposing the LC layer 80, a color filter layer 62 including a black matrix layer and a plurality of red (R), green (G), and blue (B) color elements, a common electrode 64 and a first alignment layer 66 are sequentially formed. Also, a first phase retardation plate 68 and a first polarizer 69 are sequentially disposed on the exterior surface of the upper substrate 60. The first phase retardation plate 68 is employed to involve a phase difference of 90° (or $\pi/2$) for incident light.

[0027] For the lower substrate 70, on an inner surface opposing the LC layer 80, a plurality of crossing gate lines and data lines are formed to define a plurality of pixel regions arranged in a matrix, and a plurality of TFTs are located near each cross point of two adjacent gate lines and data lines. Also, each of the pixel areas comprises a transparent electrode 72 formed on the lower substrate 70, a reflective electrode 74 patterned on the transparent electrode 72, and a second alignment layer 76 formed on the exposed surface of the transparent electrode 72 and the reflective electrode 74. Preferably, the area of the reflective electrode 74 is smaller than the area of the transparent electrode 72, thus the reflective electrode 74 covers a portion of the transparent electrode 74. The LC layer 80 over the exposed portion of the transparent electrode 72 serves as a transmissive region T, and the LC layer 80 over the reflective electrode 74 serves as a reflective region R. Moreover, a second phase retardation plate 78, a second polarizer 79 and a back light 90 are sequentially disposed on the exterior surface of the lower substrate 70. The second phase retardation plate 78 is employed to involve a phase difference of 90° (or $\pi/2$) for incident light.

[0028] Generally, the LC layer 80 of approximately $4 \mu\text{m}$ in thickness is much thicker than the reflective electrode 74 of approximately $0.1 \mu\text{m}$ in thickness, thus the LC layer 80 is certainly viewed as a single cell gap within each pixel area. According to the different pretilt angles of liquid crystal molecules, the LC layer 80 provides a first pretilt-angle region 80I and a second pretilt-angle region 80II within the reflective region R, and a third pretilt-angle region 80III and a fourth pretilt-angle region 80IV within the transmissive region R. Also, the first pretilt-angle region 80I and third pretilt-angle region 80III are adjacent to the first alignment layer 66, and the second pretilt-angle region 80II and the fourth pretilt-angle region 80IV are adjacent to the second alignment layer 76.

[0029] The present invention uses a photo-alignment process to adjust patterns on the alignment layers **66** and **76** so as to control the pretilt-angle difference between the four pretilt-angle regions **80I**, **80II**, **80III** and **80IV**. Preferably, the LC layer **80** provides at least two pretilt angles to make the phase retardation of the transmissive region T identical to the phase retardation of the reflective region R. Thus, one light path passing through the reflective region R is twice the other light path passing through the transmissive region T.

[0030] According to the photo-alignment process and the pattern design for the alignment layers **66** and **76**, the LC layer **80** may serve as a quadruple pretilt-angle structure, a triple pretilt-angle structure or a dual pretilt-angle structure. Various modes of the multi pretilt-angle structure are described hereinafter with references in **FIG. 3A**, **3B** and **3C**.

[0031] **FIG. 3A** is a cross-sectional view illustrating a transmissive LCD device with a dual pretilt-angle structure according to the present invention. For the reflective region R, a first LC molecule **80A**, within the first pretilt-angle region **80I** and the second pretilt-angle region **80II**, tilts steeply to have a first pretilt angle (an included angle between X axis and the long axis of LC molecule) of 40° ~ 45° . Meanwhile, for the transmissive region T, a second LC molecule **80B**, within the third pretilt-angle region **80III** and the fourth pretilt-angle region **80IV**, tilts gradually to have a second pretilt angle (an included angle between X axis and the long axis of LC molecule) of 0° ~ 7° . Proved by experimental simulation, the first LC molecule **80A** and the second LC molecule **80B** have different pretilt angles that effectively compensate for the difference of phase retardation between the reflective region R and the transmissive region T. Compared with the conventional dual cell gaps with the single pretilt-angle structure, the present invention develops the dual pretilt-angle structure within the single cell gap to prevent complicated processes and achieve a superior display result.

[0032] **FIG. 3B** is a cross-sectional view illustrating a transmissive LCD device with a triple pretilt-angle structure according to the present invention. For the reflective region R, a first LC molecule **80A** within the first pretilt-angle region **80I** tilts more steeply to have a first pretilt angle (an included angle between X axis and the long axis of LC molecule) of 60° ~ 85° , and a second LC molecule **80B** within the second pretilt-angle region **80II** tilts steeply to have a second pretilt angle (an included angle between X axis and the long axis of LC molecule) of 40° ~ 45° . Meanwhile, for the transmissive region T, a third LC molecule **80C**, within the third pretilt-angle region **80III** and the fourth pretilt-angle region **80IV**, tilts gradually to have a third pretilt angle (an included angle between the X axis and the long axis of LC molecule) of 0° ~ 7° . Proved by experimental simulation, the first LC molecule **80A**, the second LC molecule **80B** and the third LC molecule **80C** have three pretilt angles that effectively compensate for the difference of phase retardation between the reflective region R and the transmissive region T.

[0033] **FIG. 3C** is a cross-sectional view illustrating a transmissive LCD device with a quadruple pretilt-angle structure according to the present invention. For the reflective region R, a first LC molecule **80A** within the first pretilt-angle region **80I** tilts more steeply to have a first

pretilt angle (an included angle between X axis and the long axis of LC molecule) of 60° ~ 85° , and a second LC molecule **80B** within the second pretilt-angle region **80II** tilts steeply to have a second pretilt angle (an included angle between X axis and the long axis of LC molecule) of 40° ~ 45° . Meanwhile, for the transmissive region T, a third LC molecule **80C** within the third pretilt-angle region **80III** tilts to make its long axis parallel to the Z axis, and a fourth LC molecule **80D** within the fourth pretilt-angle region **80IV** tilts gradually to have a third pretilt angle (an included angle between X axis and the long axis of LC molecule) of 0° ~ 7° . Proved by experimental simulation, the first LC molecule **80A**, the second LC molecule **80B**, the third LC molecule **80C** and the fourth LC molecule **80D** have four pretilt angles that effectively compensate for the difference of phase retardation between the reflective region R and the transmissive region T.

[0034] In addition, in photo-alignment processing for designing the pattern of the alignment layers **66** and **76**, a UV aligner with a multi-domain photo mask is employed to dominate exposure levels on a photosensitive polymer based alignment material, thus modulates the patterns on the alignment layers **66** and **76** to benefit the multi pretilt-angle structures. The photo-alignment process is described as follows.

[0035] **FIG. 4** is a cross-sectional view illustrating a photo-alignment method. **FIG. 5A** is a plane view of a pattern on a multi-domain photo mask of **FIG. 4**. **FIG. 5B** is a plane view of a pattern on an alignment layer of **FIG. 4**. First, a substrate **92** is provided with a photo-alignment film **94** formed thereon. Then, a light source **96** is provided and the radiated light (as shown by the dotted lines) passes through a polarizer **98**, a condenser **100** and a multi-domain photo mask **102**. The multi-domain photo mask **102** comprises a plurality of first regions **102I** that permit the incident light toward a first direction to pass through, and a plurality of second regions **102II** that permits the incident light toward a second direction to pass through. By modulating the exposure level, a plurality of first alignment domains **94I** corresponding to the first regions **102I** is transferred to the photo-alignment film **94**, thus the LC molecules over the first alignment domains **94I** have a first pretilt angle (as shown by an arrow in the first alignment domain **94I**). In the meanwhile, and a plurality of second alignment domains **94II** corresponding to the second regions **102II** is transferred to the photo-alignment film **94**, thus the LC molecules over the second alignment domains **94II** have a second pretilt angle (as shown by an arrow in the second alignment domain **94II**).

[0036] By modifying the pattern on the multi-domain photo mask **102** and modulating the exposure levels, the above-described photo-alignment process is also applied to the triple pretilt-angle structure and the quadruple pretilt-angle structure.

[0037] While the invention has been described by way of example and in terms of the preferred embodiments, it is to be understood that the invention is not limited to the disclosed embodiments. To the contrary, it is intended to cover various modifications and similar arrangements (as would be apparent to those skilled in the art). Therefore, the scope of the appended claims should be accorded the broadest interpretation so as to encompass all such modifications and similar arrangements.

1-15. (cancelled)

16. A fabrication method for a transfective display device with different pretilt angles, comprising steps of:

providing an upper substrate and a lower substrate opposed to each other and separated by a space;

forming a transparent electrode on the inner surface of the lower substrate;

forming a reflective electrode on a portion of the transparent electrode, in which a reflective region is defined over the reflective electrode, and a transmissive region is defined over the transparent electrode which is not covered by the reflective electrode;

forming a first alignment layer on the inner surface of the upper substrate, in which the first alignment layer comprises at least two alignment domains;

forming a second alignment layer formed on the reflective electrode and the exposed surface of the transparent electrode, in which the second alignment layer comprises at least two alignment domains;

forming a liquid crystal layer in the space between the upper substrate and the lower substrate and sandwiched between the first alignment layer and the second alignment layer, in which the liquid crystal layer serves as a single cell gap;

wherein, the liquid crystal layer comprises a first pretilt-angle region in the reflective region and adjacent to the first alignment layer;

wherein, the liquid crystal layer comprises a second pretilt-angle region in the reflective region and adjacent to the second alignment layer;

wherein, the liquid crystal layer comprises a third pretilt-angle region in the transmissive region and adjacent to the first alignment layer;

wherein, the liquid crystal layer comprises a fourth pretilt-angle region in the transmissive region and adjacent to the second alignment layer; and

wherein, the liquid crystal molecules have at least two pretilt angles in the first pretilt-angle region, the second pretilt-angle region, the third pretilt-angle region, and the fourth pretilt-angle region.

17. The fabrication method for a transfective display device with different pretilt angles of claim 16, wherein the pretilt angle of the liquid crystal molecule in the reflective region is different from the pretilt angle of the liquid crystal molecule in the transmissive region, the reflective region and the transmissive region have the same phase retardation, and the light path passing through the reflective region is twice the light path passing through the transmissive region.

18. The fabrication method for a transfective display device with different pretilt angles of claim 16, wherein the method of forming the first alignment layer and the second alignment layer comprises steps of:

providing a photo-alignment film;

providing a multi-domain photo mask, in which a plurality of first regions permits an incident light toward a first direction to pass through, and a plurality of second regions permits an incident light toward a second direction to pass through;

providing a light source which radiates light to pass through the multi-domain photo mask to reach the photo-alignment film; and

controlling exposure level to form a plurality of alignment domains on the photo-alignment film.

19. The fabrication method for a transfective display device with different pretilt angles of claim 16, wherein the method of forming the first alignment layer and the second alignment layer employs a photo alignment process, rubbing, an ion-beam process or slanting deposition.

20. The fabrication method for a transfective display device with different pretilt angles of claim 16, further comprising steps of:

forming a color filter layer on the inner surface of the upper substrate; and

forming a common electrode formed on the color filter layer;

wherein, the color filter layer and the common electrode are sandwiched between the upper substrate and the first alignment layer.

21. The fabrication method for a transfective display device with different pretilt angles of claim 16, further comprising steps of:

forming a first phase retardation plate on the exterior surface of the upper substrate; and

forming a first polarizer disposed on the first phase retardation;

wherein, the first phase retardation plate involves a phase difference of 90° or $\pi/2$ for incident light.

22. The fabrication method for a transfective display device with different pretilt angles of claim 16, further comprising:

forming a second phase retardation plate on the exterior surface of the lower substrate; and

forming a second polarizer on the second phase retardation;

wherein, the second phase retardation plate involves a phase difference of 90° or $\pi/2$ for incident light.

23. The fabrication method for a transfective display device with different pretilt angles of claim 16, further comprising a step of:

providing a back light on the exterior surface of the lower substrate.

* * * * *

专利名称(译)	具有不同预倾角的半透射显示装置及其制造方法		
公开(公告)号	US20050018115A1	公开(公告)日	2005-01-27
申请号	US10/923586	申请日	2004-08-20
[标]申请(专利权)人(译)	财团法人工业技术研究院		
申请(专利权)人(译)	工业技术研究院		
当前申请(专利权)人(译)	群创光电		
[标]发明人	LIAO CHIH CHANG WONG YICHUN LIU KANG HUNG FAN YANG YI		
发明人	LIAO, CHIH-CHANG WONG, YICHUN LIU, KANG-HUNG FAN, YANG-YI		
IPC分类号	G02F1/137 G02F1/1335 G02F1/1337 G09F9/30 G09F9/35		
CPC分类号	G02F1/133753		
优先权	091136410 2002-12-17 TW		
其他公开文献	US6961107		
外部链接	Espacenet USPTO		

摘要(译)

透反射显示装置具有单个单元间隙，其中液晶分子具有至少两个预倾角。透明电极形成在下基板的内表面上，反射电极形成在透明电极的一部分上。因此，在反射电极上方形成反射区域，在透明电极上方形成未被反射电极覆盖的透射区域。利用光取向工艺在夹着液晶层的两个取向层中的每一个上形成至少两个取向区域，液晶分子在反射区域中的预倾角不同于液晶分子的预倾角。透射区域，反射区域和透射区域具有相同的相位延迟，并且穿过反射区域的光路是穿过透射区域的光路的两倍。

