



US007738050B2

(12) **United States Patent**  
**Yamazaki et al.**

(10) **Patent No.:** **US 7,738,050 B2**  
(45) **Date of Patent:** **Jun. 15, 2010**

(54) **LIQUID CRYSTAL DISPLAY DEVICE**

(75) Inventors: **Shunpei Yamazaki**, Setagaya (JP);  
**Yukie Suzuki**, Atsugi (JP); **Hideaki**  
**Kuwabara**, Isehara (JP); **Hajime**  
**Kimura**, Atsugi (JP)

5,514,879 A 5/1996 Yamazaki  
5,614,732 A 3/1997 Yamazaki  
5,648,662 A 7/1997 Zhang et al.  
5,701,167 A 12/1997 Yamazaki  
5,766,989 A 6/1998 Maegawa et al.

(Continued)

(73) Assignee: **Semiconductor Energy Laboratory**  
**Co., Ltd.**, Atsugi-shi, Kanagawa-ken

**FOREIGN PATENT DOCUMENTS**

EP 1505174 2/2005

(Continued)

(\*) Notice: Subject to any disclaimer, the term of this  
patent is extended or adjusted under 35  
U.S.C. 154(b) by 158 days.

**OTHER PUBLICATIONS**

Arai, T et al., "41.2: Micro Silicon Technology for Active Matrix  
OLED Display", SID Digest 07: SID International Symposium  
Digest of Technical Papers, pp. 1370-1373.

(Continued)

(21) Appl. No.: **12/213,729**

(22) Filed: **Jun. 24, 2008**

**Prior Publication Data**

US 2009/0009677 A1 Jan. 8, 2009

*Primary Examiner*—Brian M Healy  
(74) *Attorney, Agent, or Firm*—Eric J. Robinson; Robinson  
Intellectual Property Law Office, P.C.

**Foreign Application Priority Data**

Jul. 6, 2007 (JP) ..... 2007-179092

(57) **ABSTRACT**

(51) **Int. Cl.**  
**G02F 1/136** (2006.01)  
**H01L 27/14** (2006.01)

(52) **U.S. Cl.** ..... **349/43**; 349/42; 349/56;  
349/138; 349/139; 349/147; 257/59; 257/72

(58) **Field of Classification Search** ..... 349/43,  
349/56, 42, 138, 142, 143, 147; 257/66,  
257/72, 59, 29, E21.001, E33.001

See application file for complete search history.

A method of manufacturing, with high mass productivity,  
liquid crystal display devices having highly reliable thin film  
transistors with excellent electric characteristics is provided.  
In a liquid crystal display device having an inverted staggered  
thin film transistor, the inverted staggered thin film transistor  
is formed as follows: a gate insulating film is formed over a  
gate electrode; a microcrystalline semiconductor film which  
functions as a channel formation region is formed over the  
gate insulating film; a buffer layer is formed over the micro-  
crystalline semiconductor film; a pair of source and drain  
regions are formed over the buffer layer; and a pair of source  
and drain electrodes are formed in contact with the source and  
drain regions so as to expose a part of the source and drain  
regions.

(56) **References Cited**

**U.S. PATENT DOCUMENTS**

4,409,134 A 10/1983 Yamazaki  
5,453,858 A 9/1995 Yamazaki

**26 Claims, 37 Drawing Sheets**

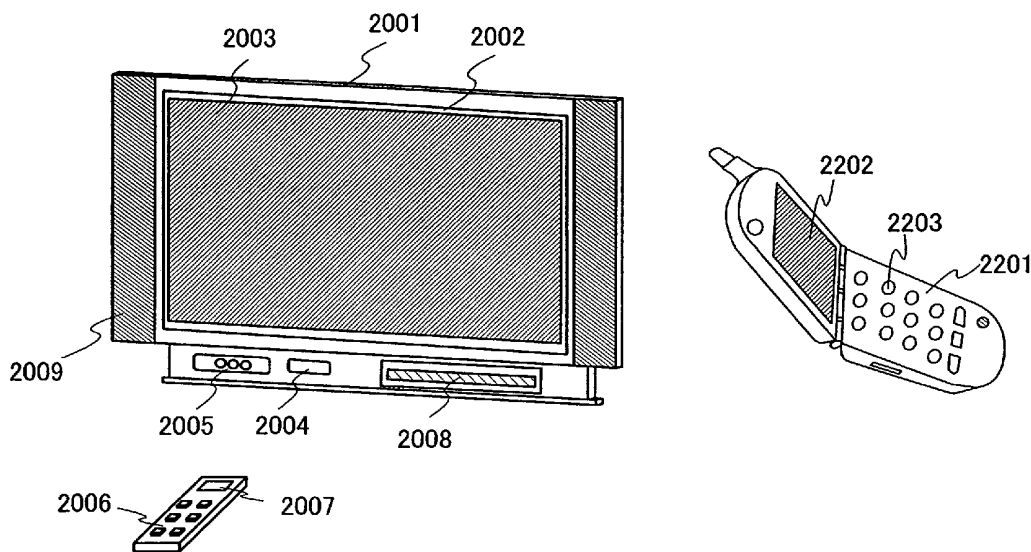

U.S. PATENT DOCUMENTS

5,849,601	A	12/1998	Yamazaki	
5,859,445	A	1/1999	Yamazaki	
5,932,302	A	8/1999	Yamazaki et al.	
6,011,277	A	1/2000	Yamazaki	
6,023,075	A	2/2000	Yamazaki	
6,171,674	B1	1/2001	Yamazaki et al.	
6,183,816	B1	2/2001	Yamazaki et al.	
6,252,249	B1	6/2001	Yamazaki	
6,281,520	B1	8/2001	Yamazaki	
6,306,213	B1	10/2001	Yamazaki	
6,468,617	B1	10/2002	Yamazaki et al.	
6,737,676	B2	5/2004	Yamazaki	
6,756,258	B2	6/2004	Zhang et al.	
6,835,523	B1	12/2004	Yamazaki et al.	
7,067,844	B2	6/2006	Yamazaki	
7,098,479	B1	8/2006	Yamazaki	
7,115,902	B1	10/2006	Yamazaki	
7,199,846	B2	4/2007	Lim	
7,417,249	B2 *	8/2008	Akimoto et al.	257/59
2005/0012097	A1	1/2005	Yamazaki	
2005/0022864	A1	2/2005	Fujioka et al.	
2005/0089648	A1	4/2005	Yamazaki et al.	
2006/0186413	A1 *	8/2006	Sakakura et al.	257/72
2006/0261336	A1 *	11/2006	Ohnuma et al.	257/59
2007/0018165	A1	1/2007	Yamazaki	
2007/0132903	A1	6/2007	Lim	

2009/0002591	A1 *	1/2009	Yamazaki et al.	349/43
2009/0039351	A1 *	2/2009	Kobayashi et al.	257/59

FOREIGN PATENT DOCUMENTS

JP	62-062073	12/1987
JP	02-053941	11/1990
JP	04-242724	8/1992
JP	2000-277439	10/2000
JP	2001-007024	1/2001
JP	2004-014958	1/2004
JP	2005-049832	2/2005
JP	2005-050905	2/2005
JP	2005-167051	6/2005

OTHER PUBLICATIONS

C. W. Kim et al., "42.1: A Novel Four-Mask-Count Process Architecture for TFT-LCDs", SID Digest 00: SID International Symposium Digest of Technical Papers, pp. 1006-1009.

Jean H. Song et al., "34.1: Advanced Four-Mask Process Architecture for the a-Si TFT Array Manufacturing Method", SID Digest 02: SID International Symposium Digest of Technical Papers, pp. 1038-1041.

Seungjin Choi et al., "P-16: Novel Four-Mask Process in the FFS TFT-LCD with Optimum Multiple-Slit Design Applied by the use of a Gray-Tone Mask", SID Digest 05: SID International Symposium Digest of Technical Papers, pp. 284-287.

\* cited by examiner

FIG. 1A

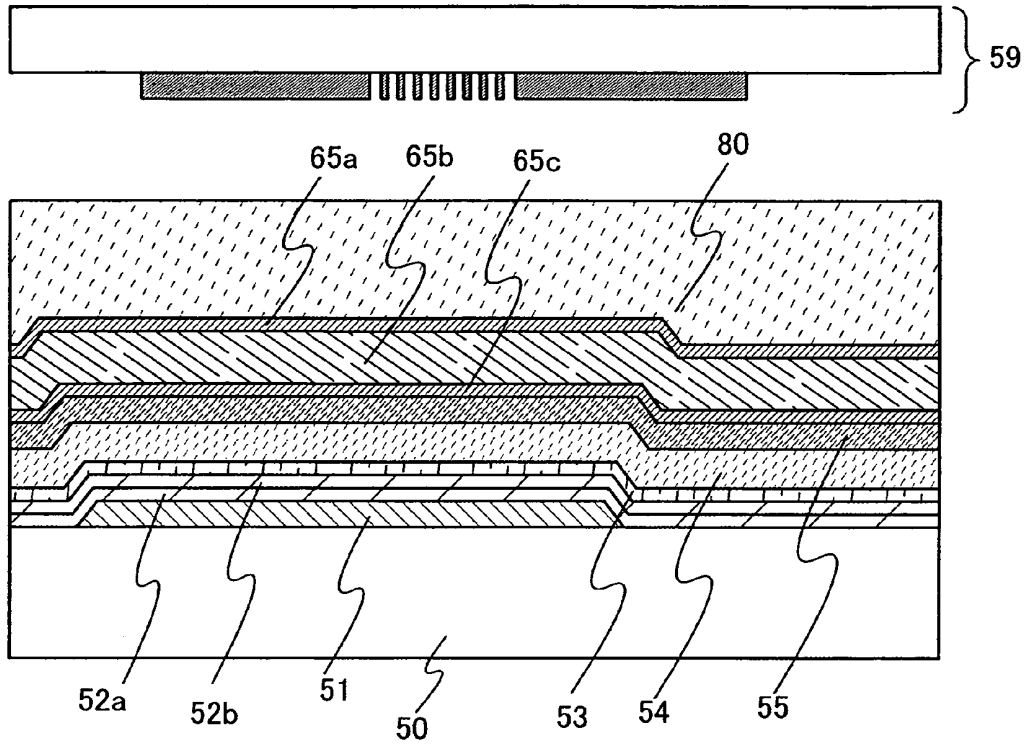

FIG. 1B

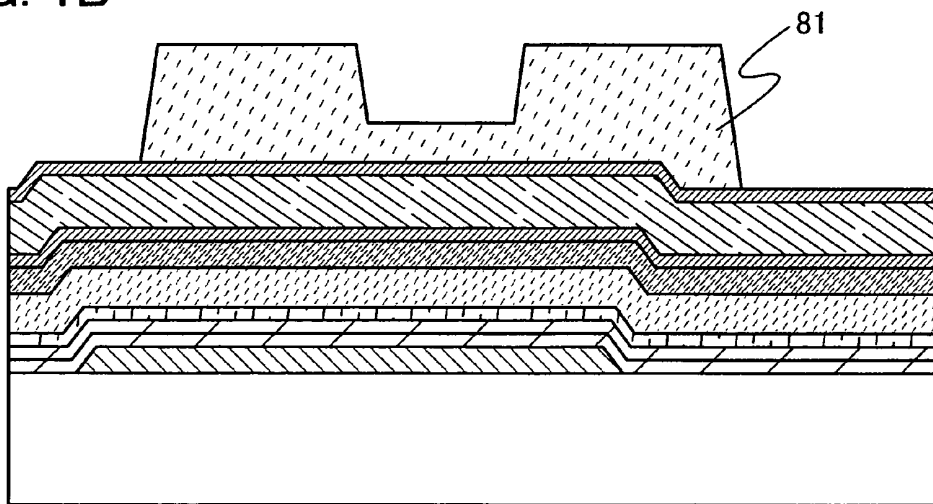

FIG. 2A

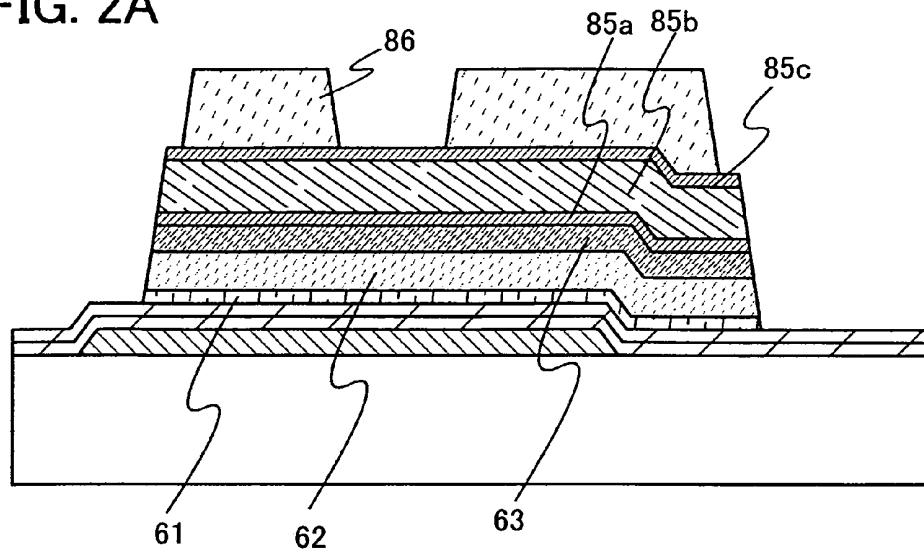

FIG. 2B

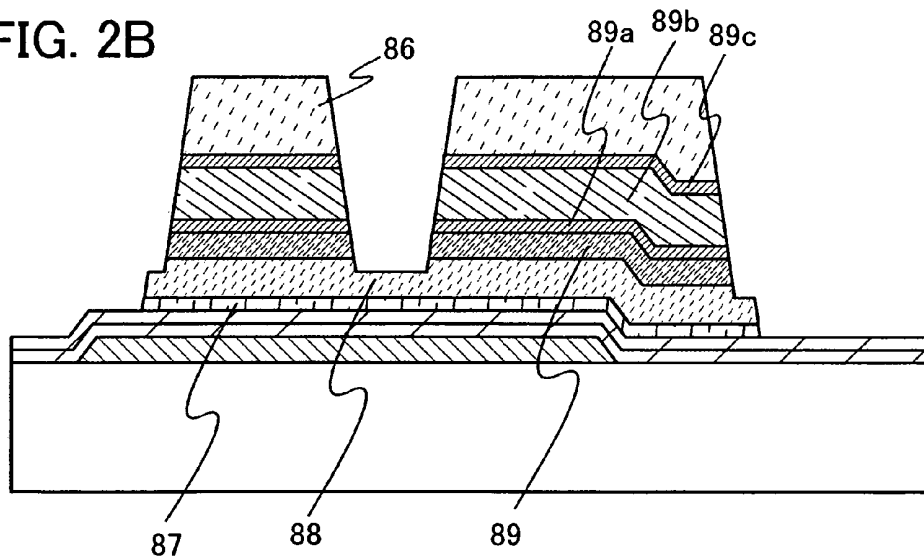

FIG. 2C

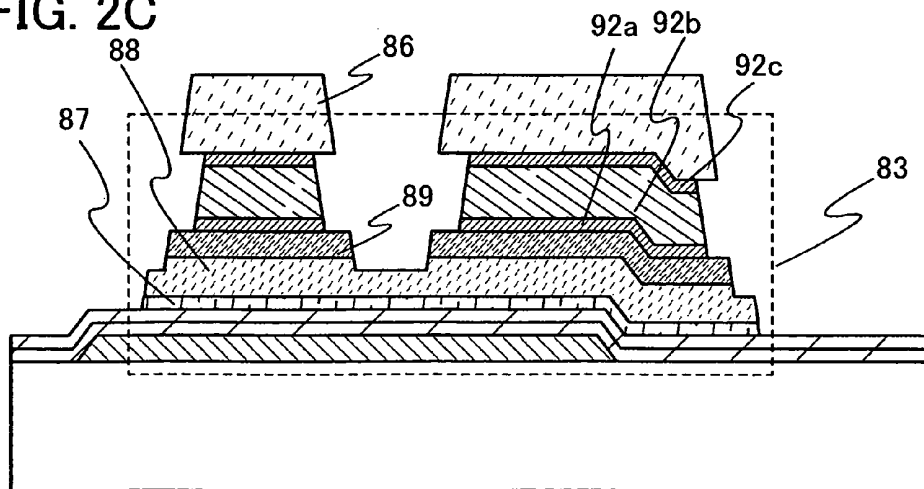

FIG. 3A

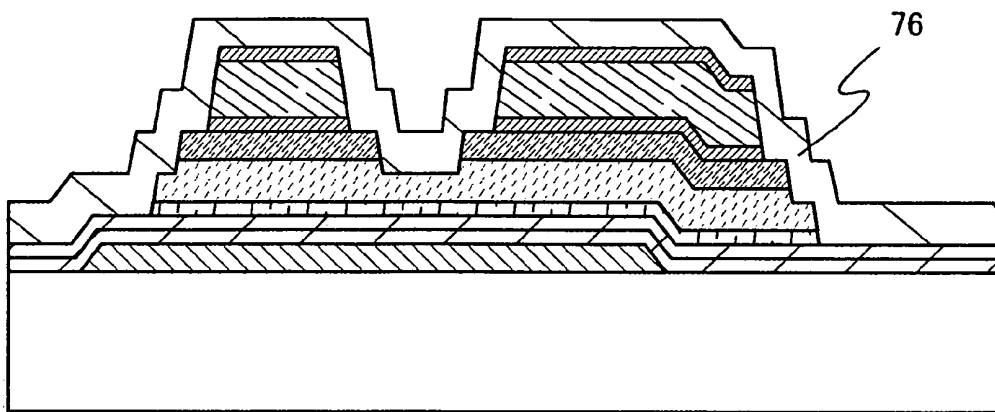

FIG. 3B

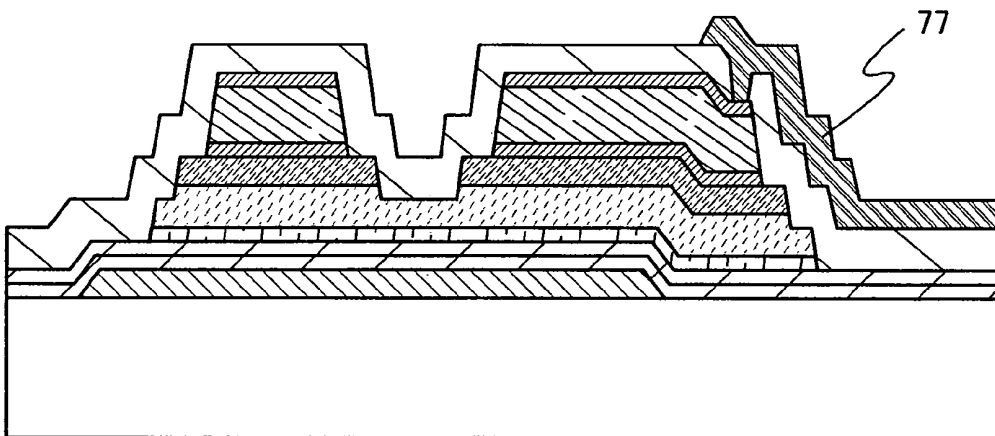

FIG. 4A

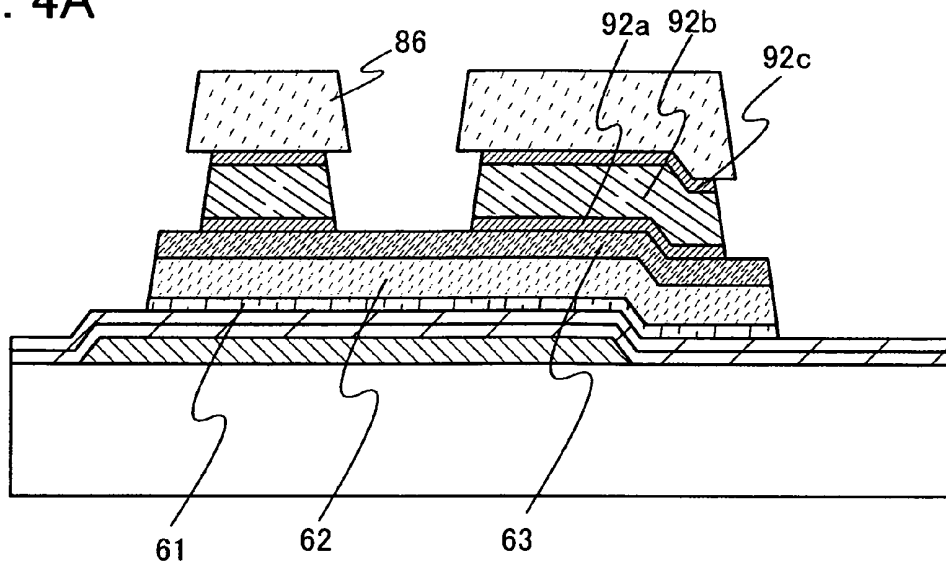

FIG. 4B

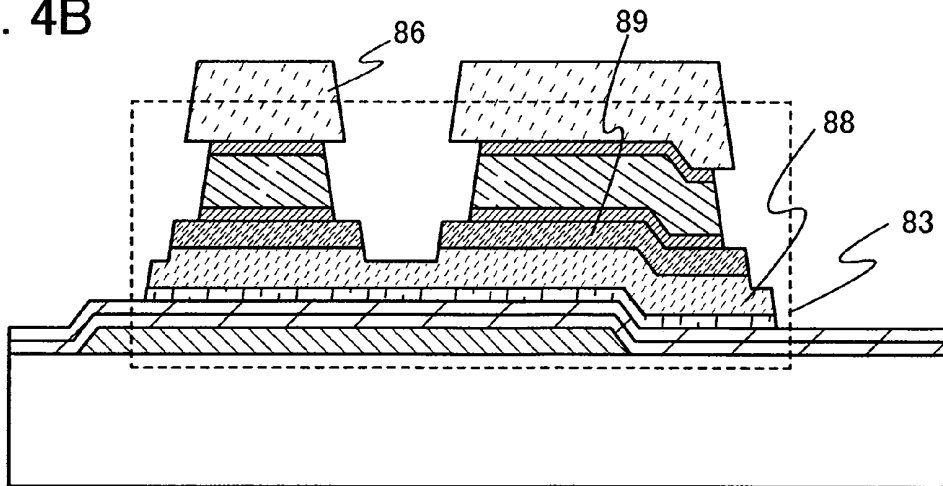

FIG. 5B

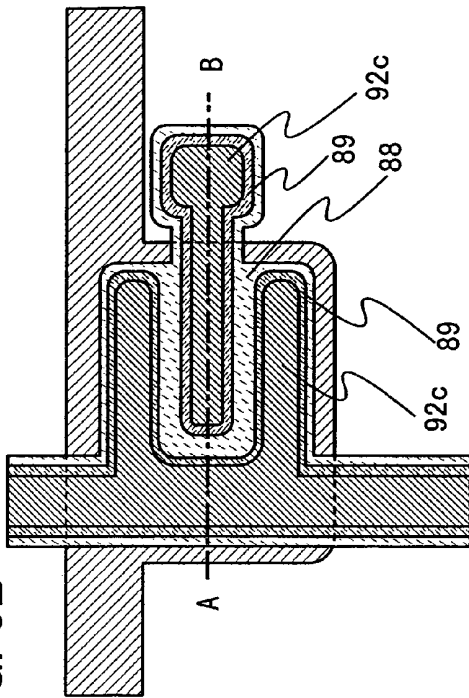

FIG. 5A

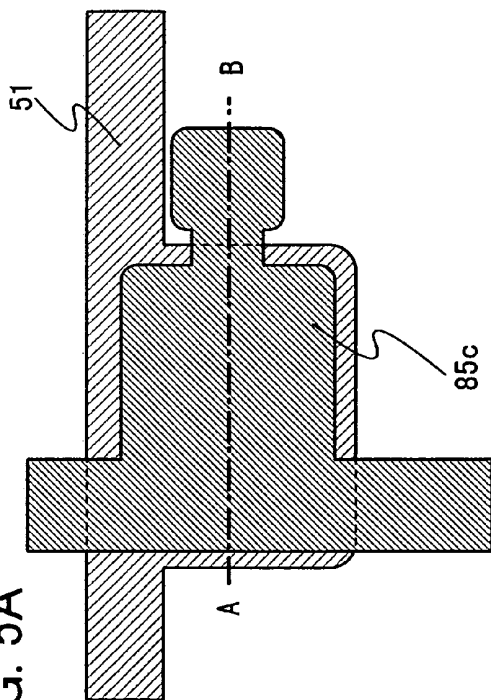

FIG. 5C

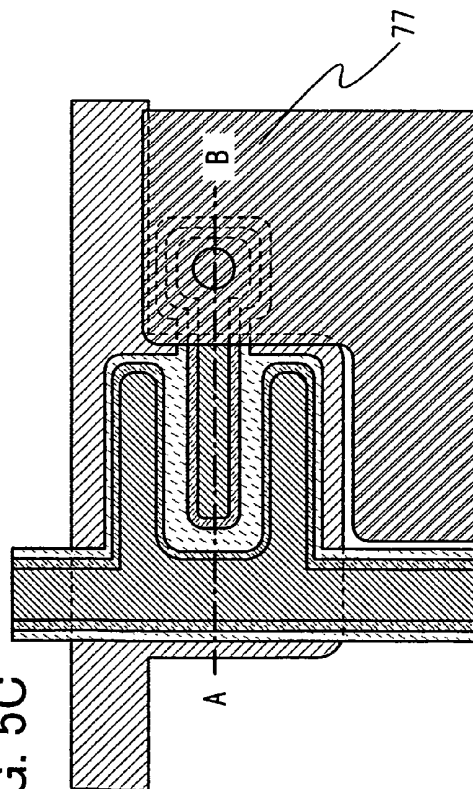

FIG. 6A

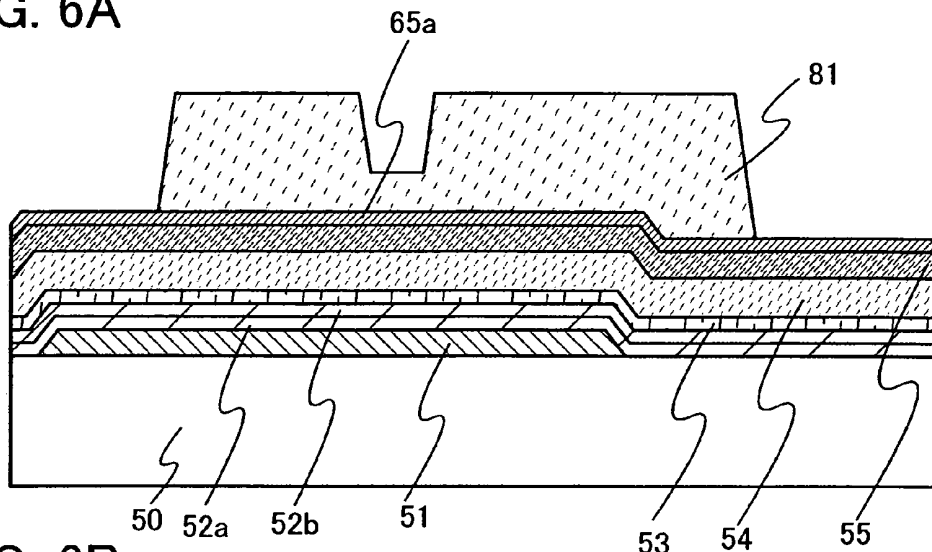

FIG. 6B

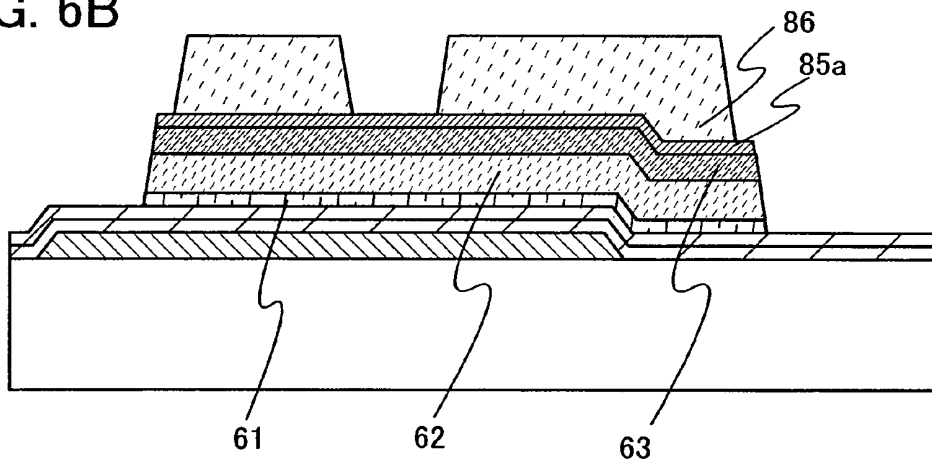

FIG. 6C

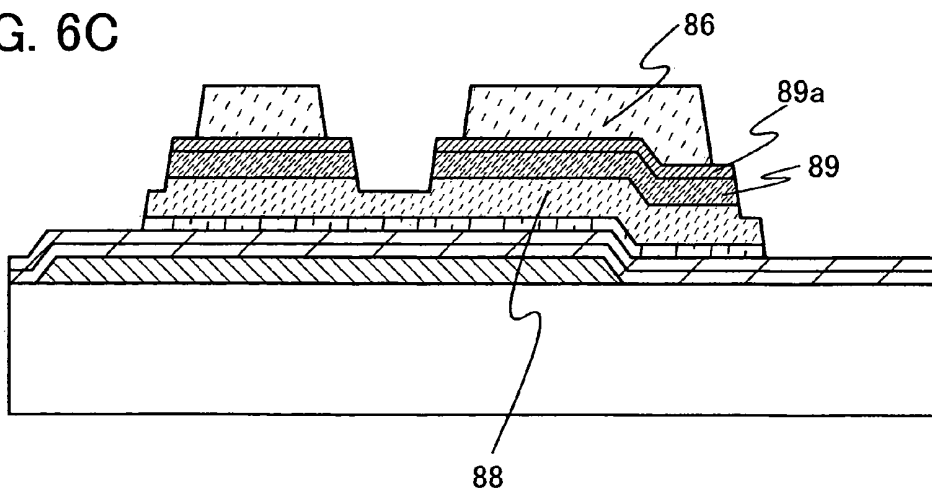

FIG. 7A

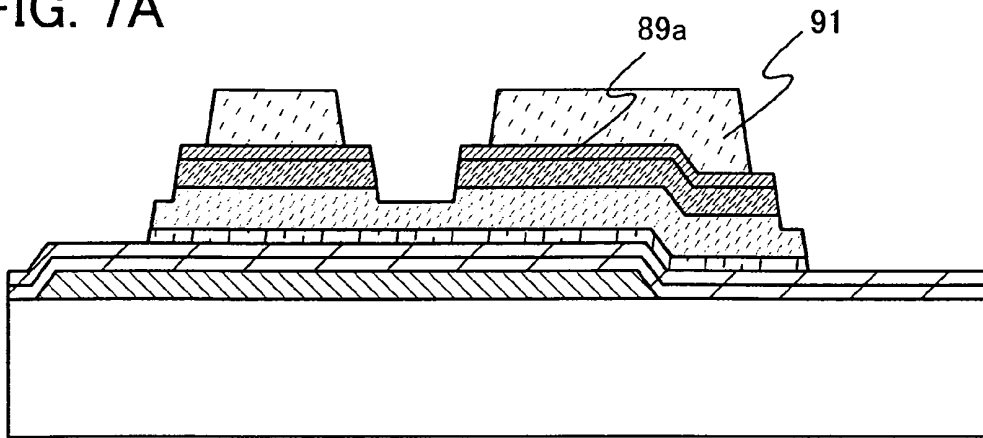

FIG. 7B

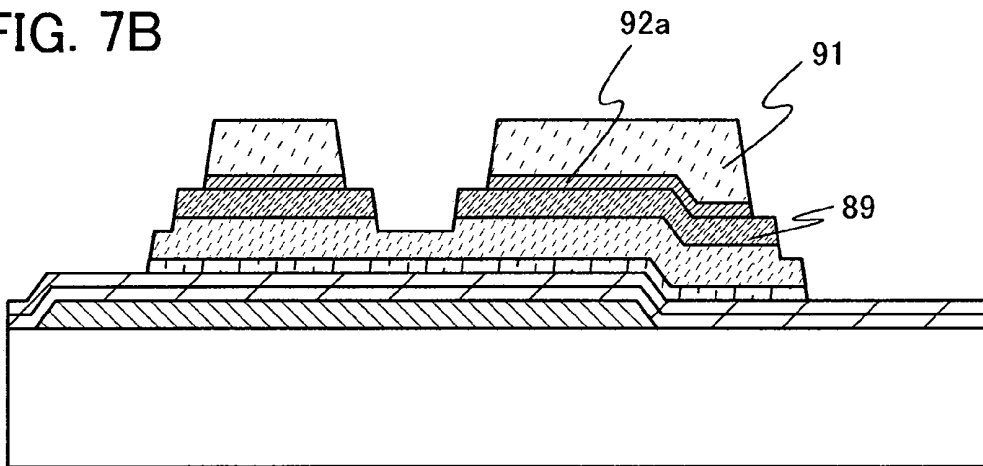

FIG. 7C

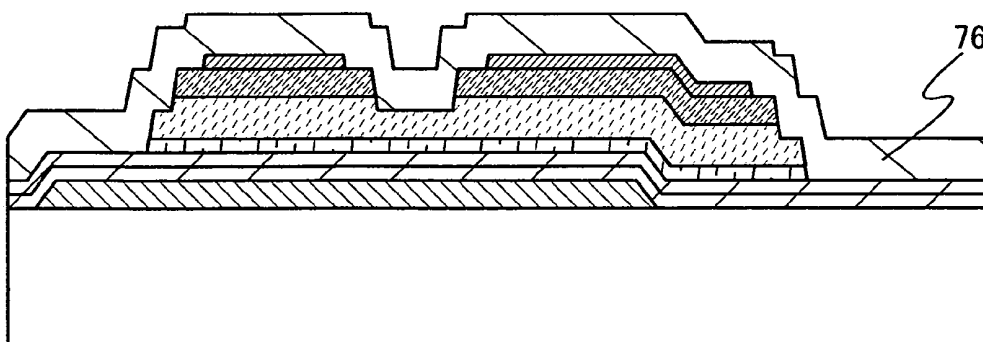

FIG. 8A

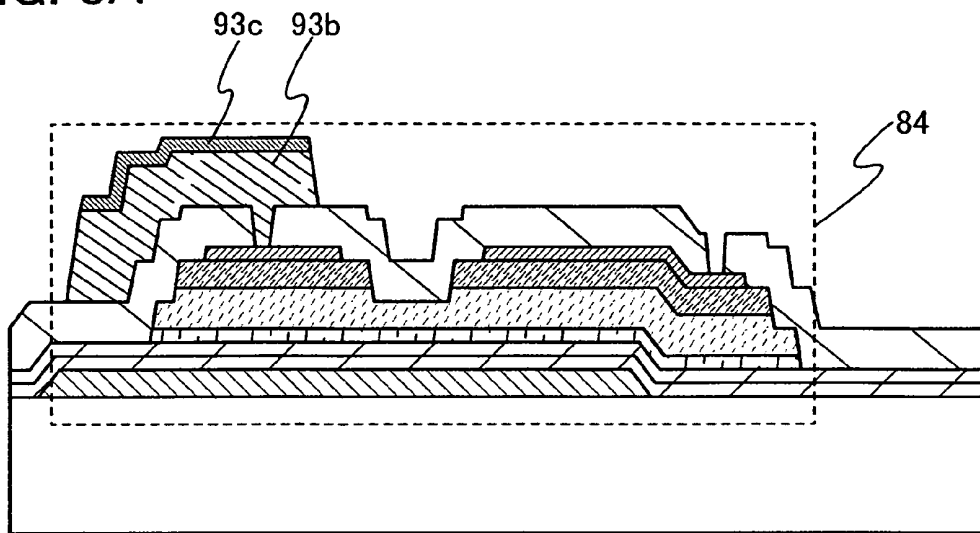

FIG. 8B

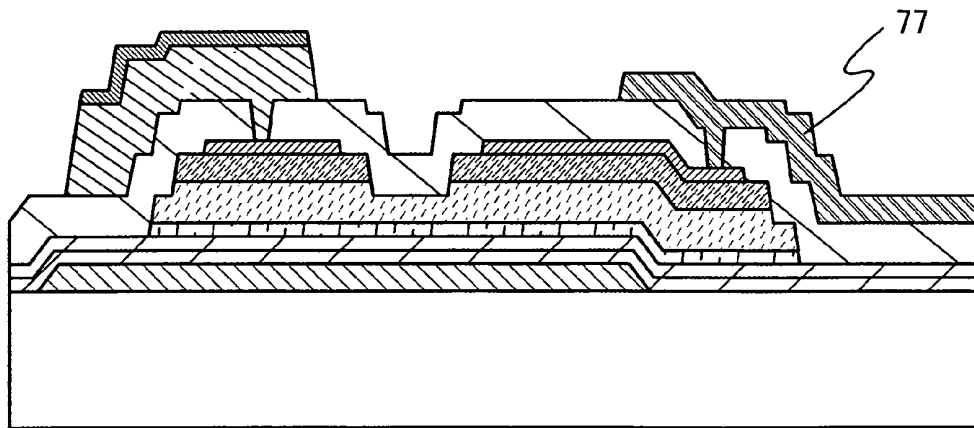

FIG. 9A

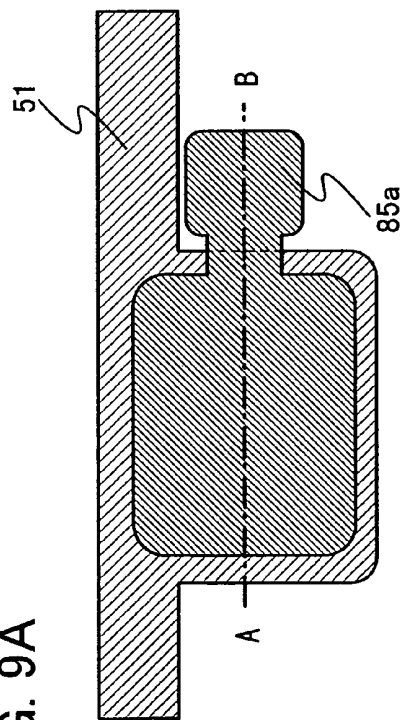

FIG. 9B

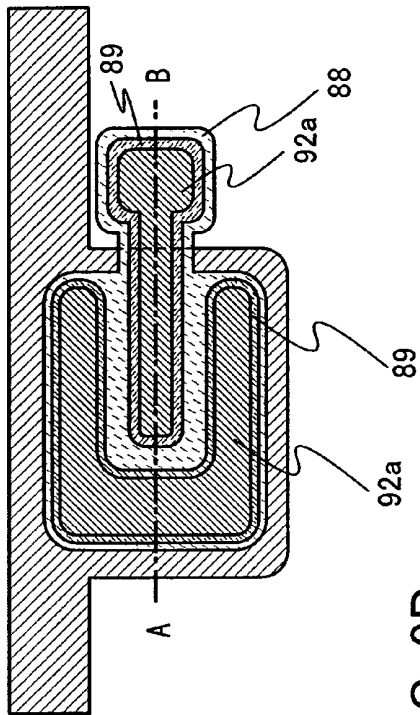

FIG. 9C

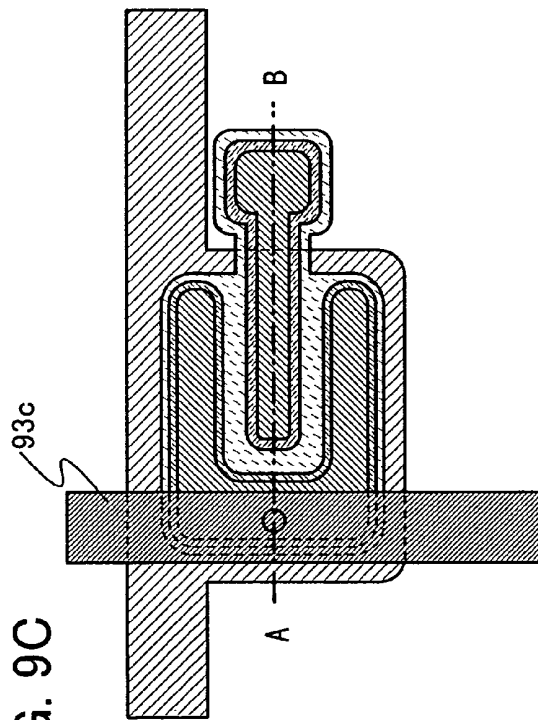

FIG. 9D

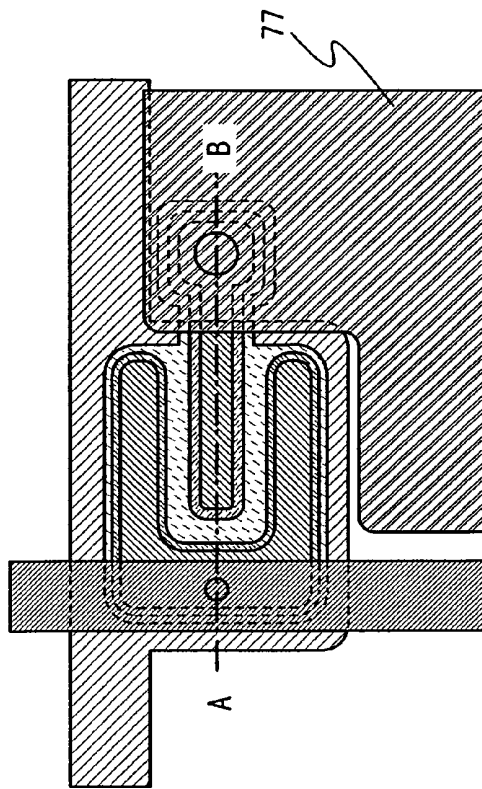

FIG. 10

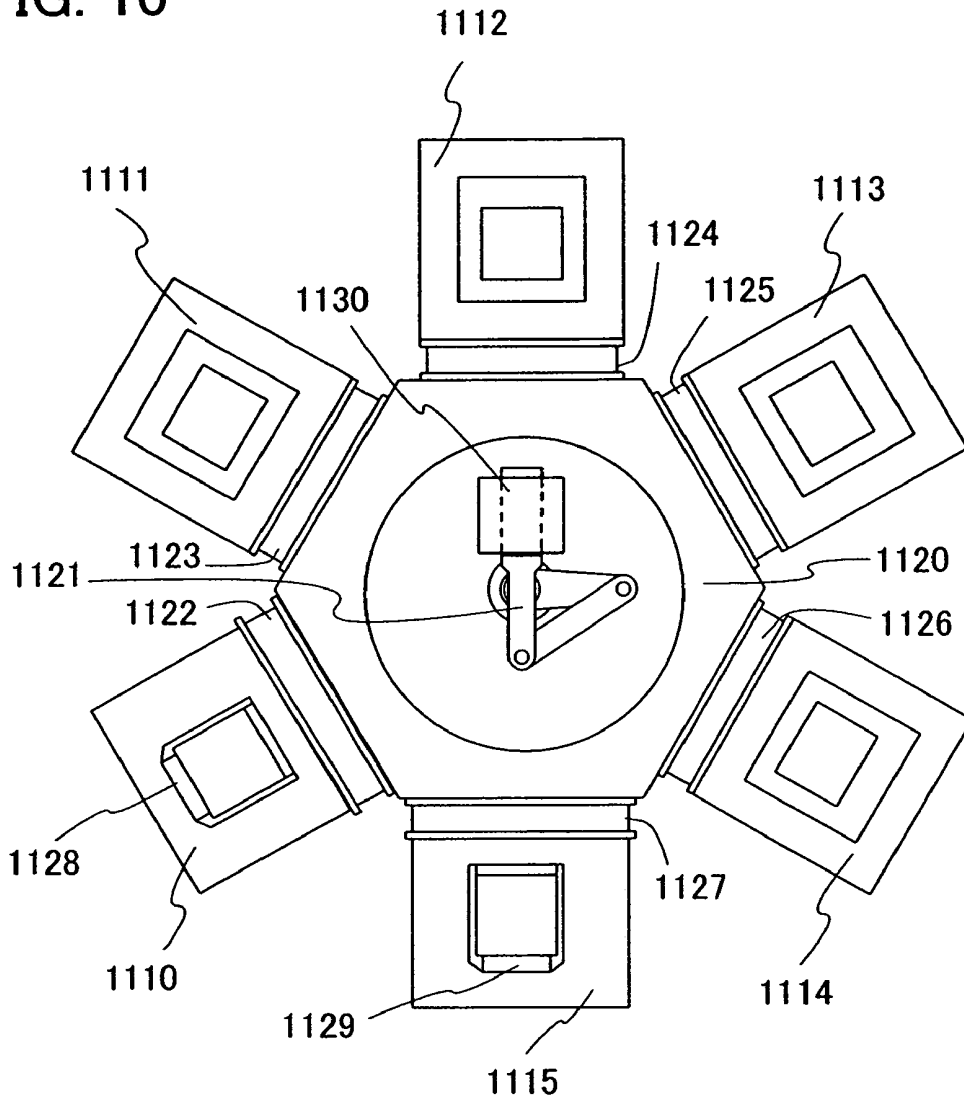

FIG. 11A

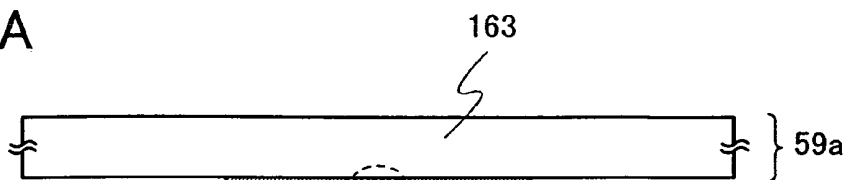
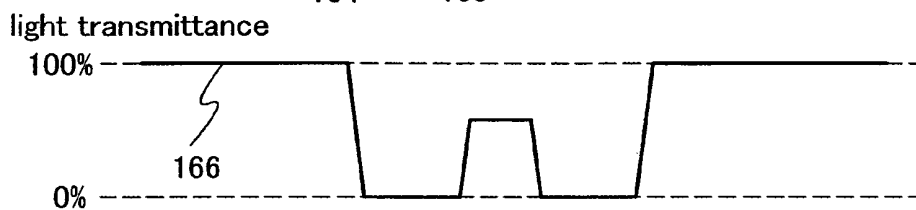

FIG. 11B



164 165

FIG. 11C

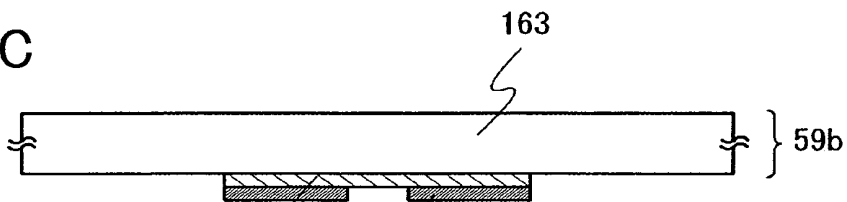
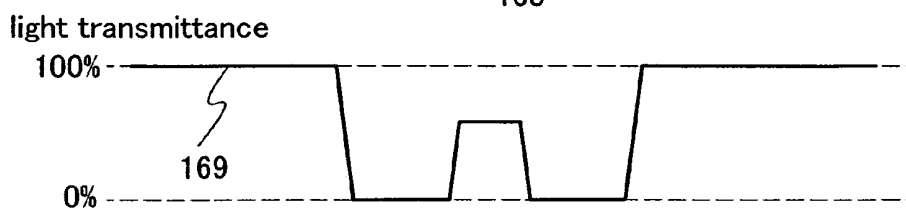

FIG. 11D



167 168

FIG. 12A

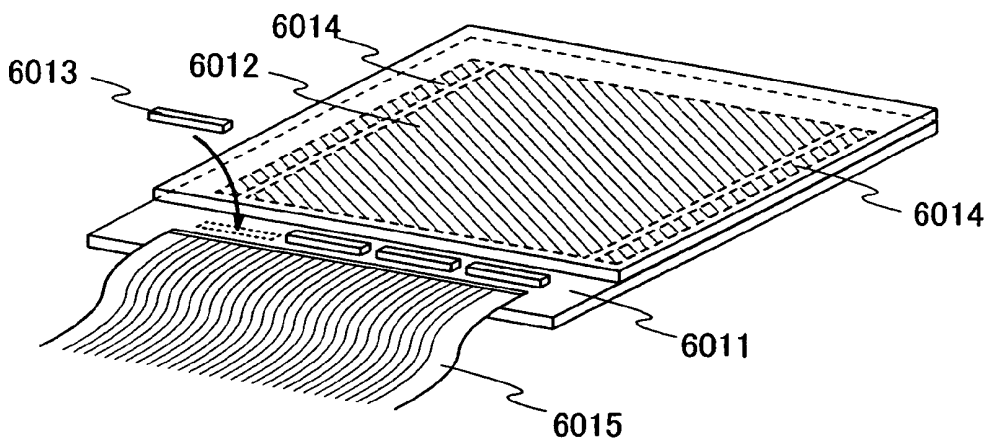

FIG. 12B

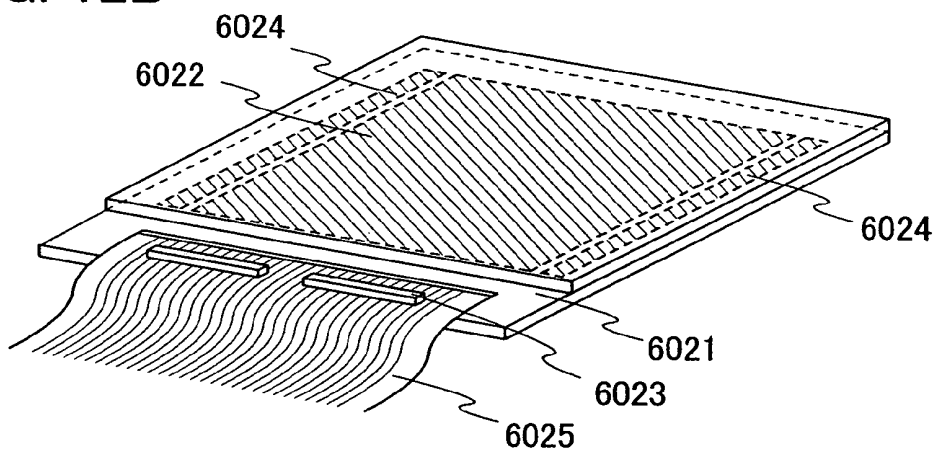

FIG. 12C

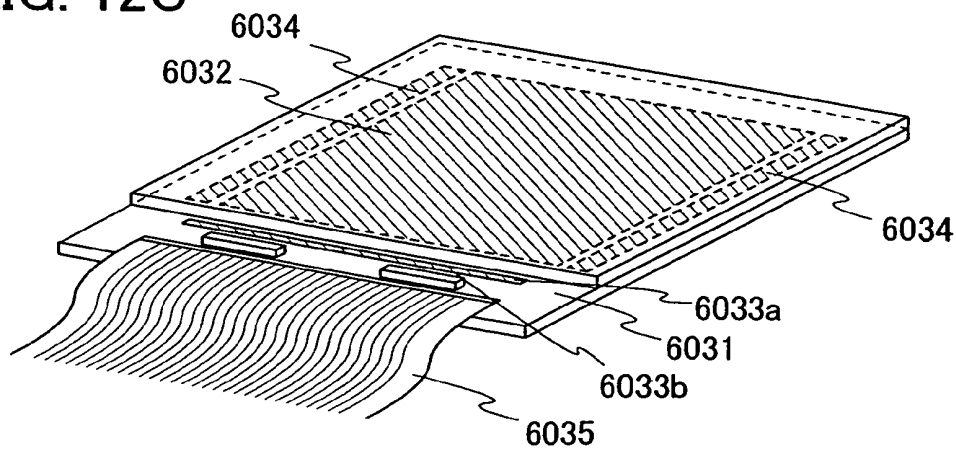

FIG. 13A

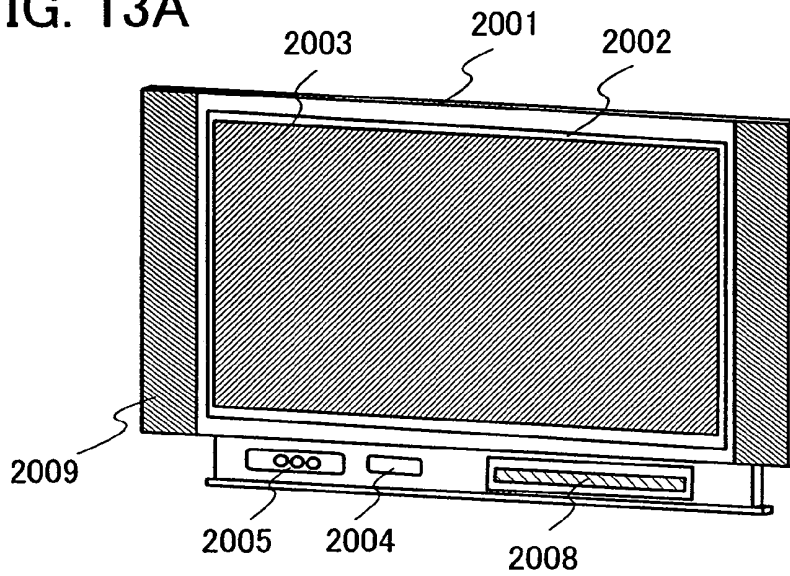

FIG. 13B

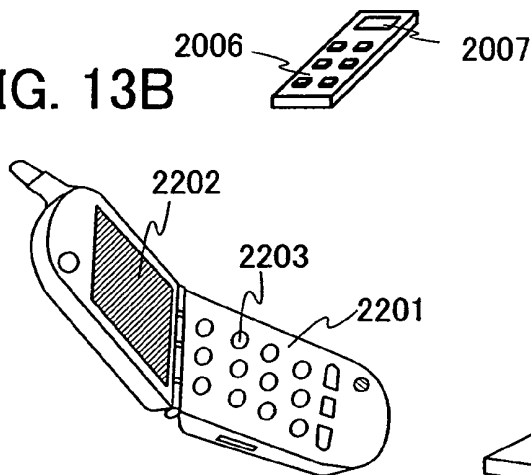

FIG. 13C

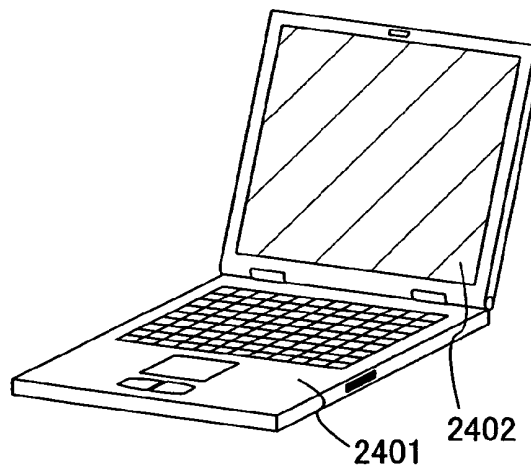

FIG. 14

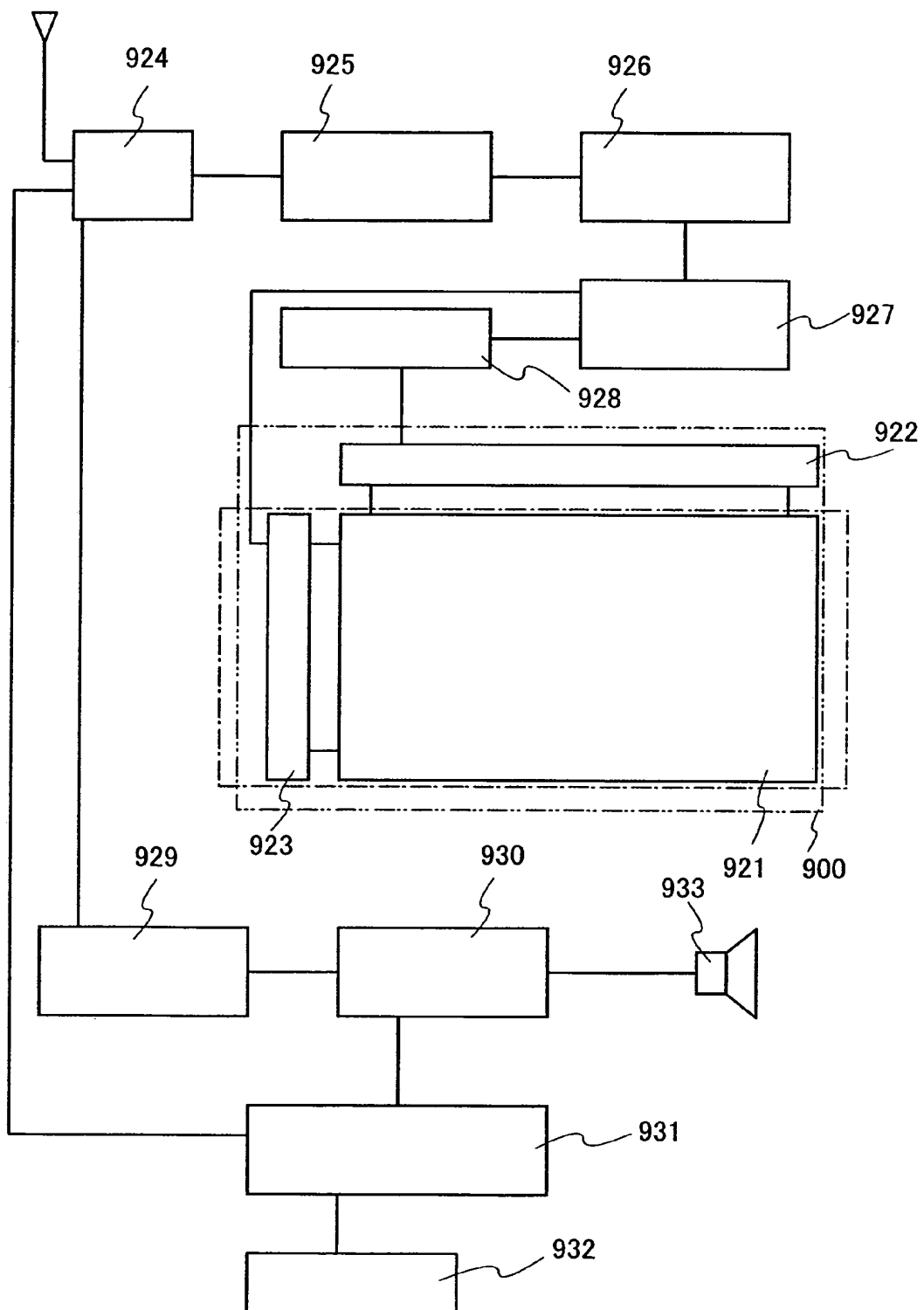

FIG. 15

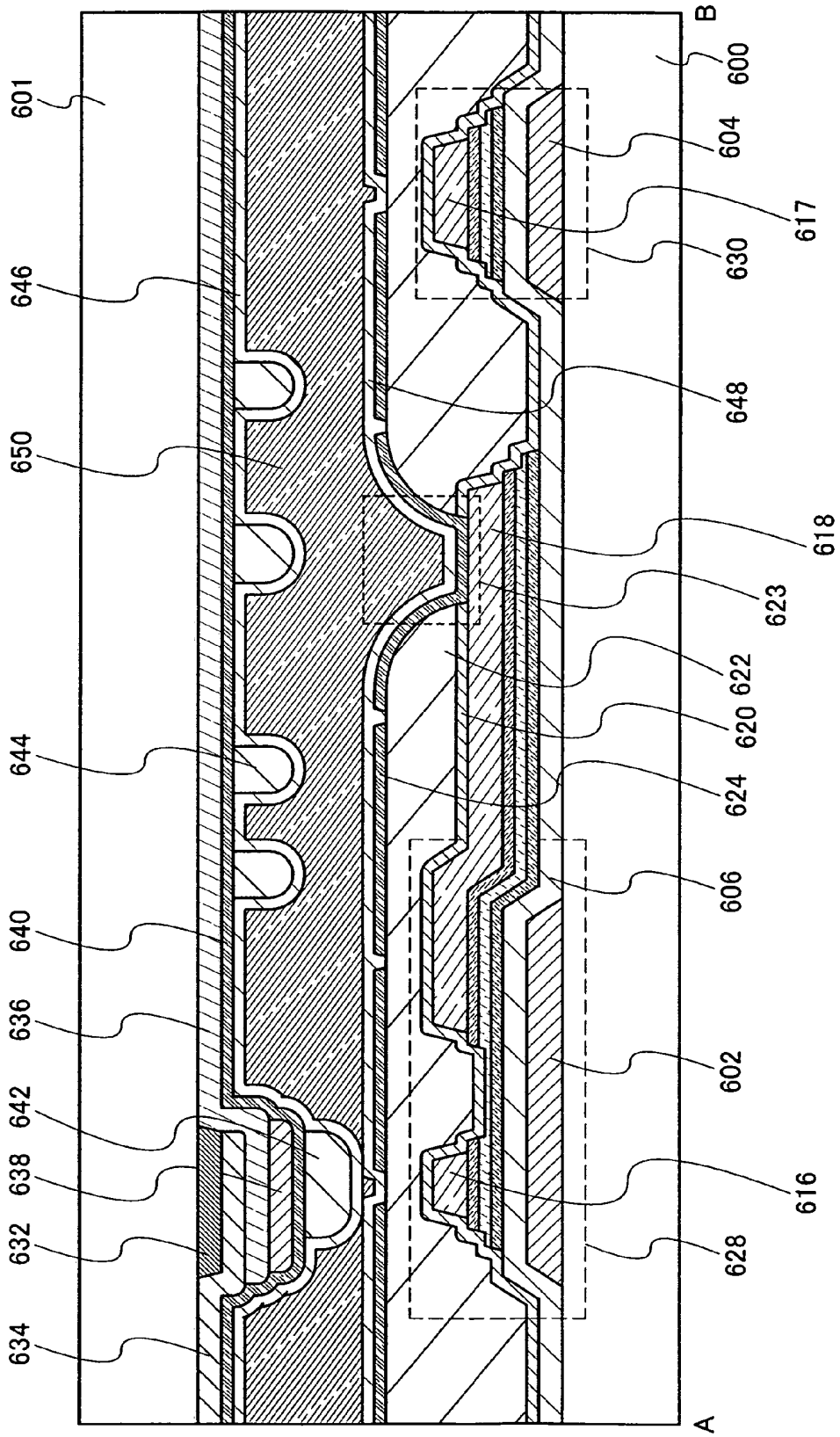

FIG. 16

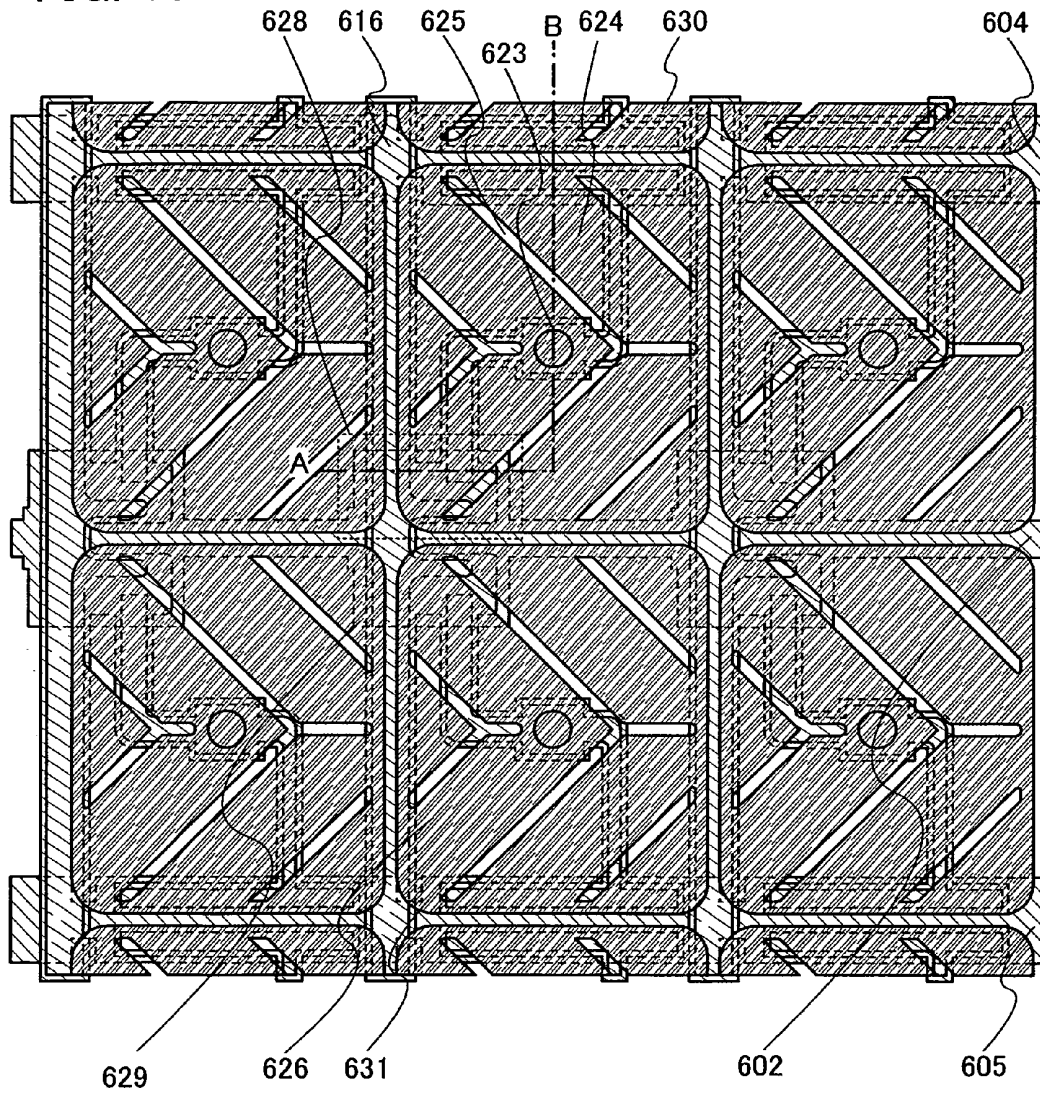

FIG. 17

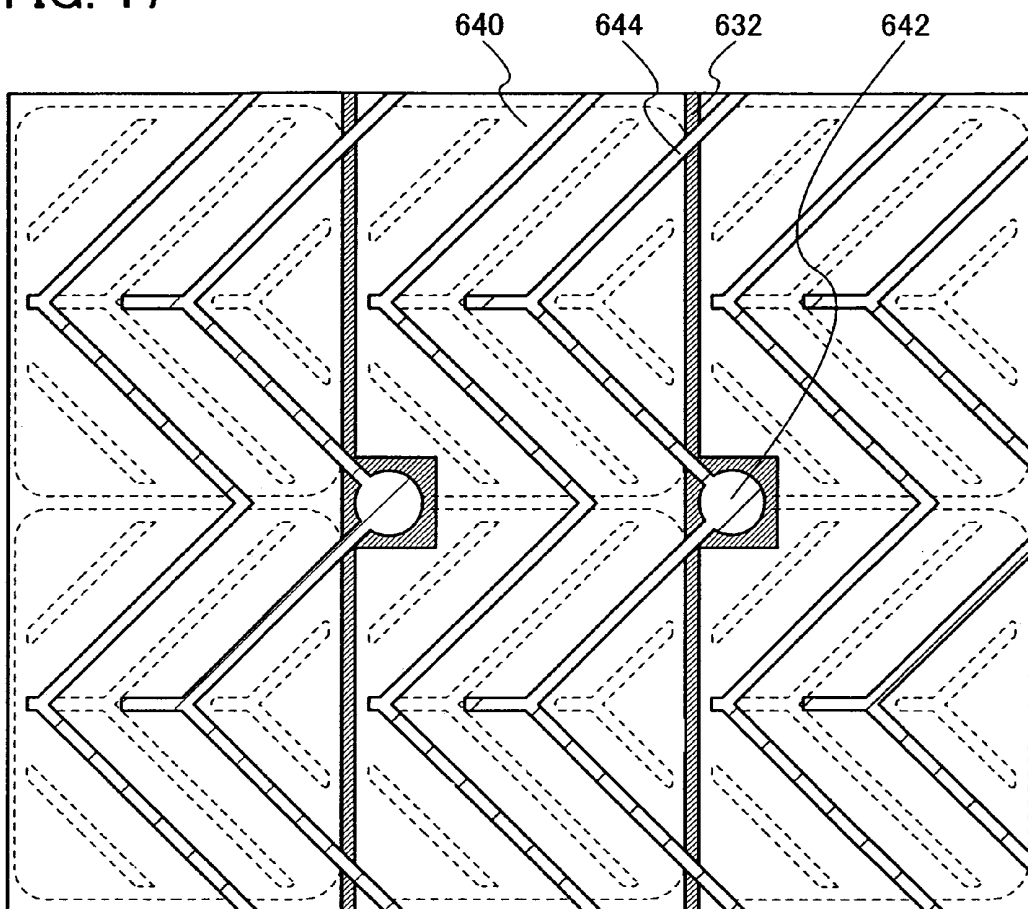

FIG. 18

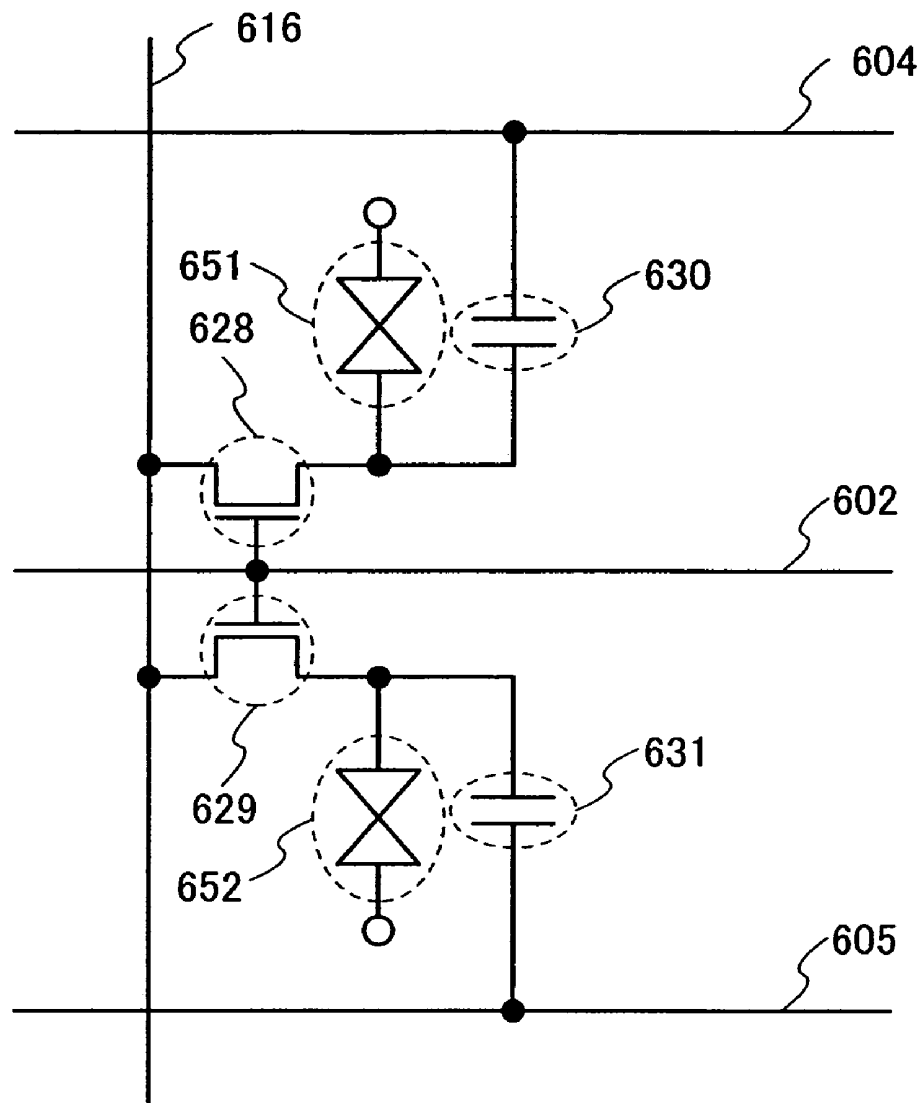

FIG. 19

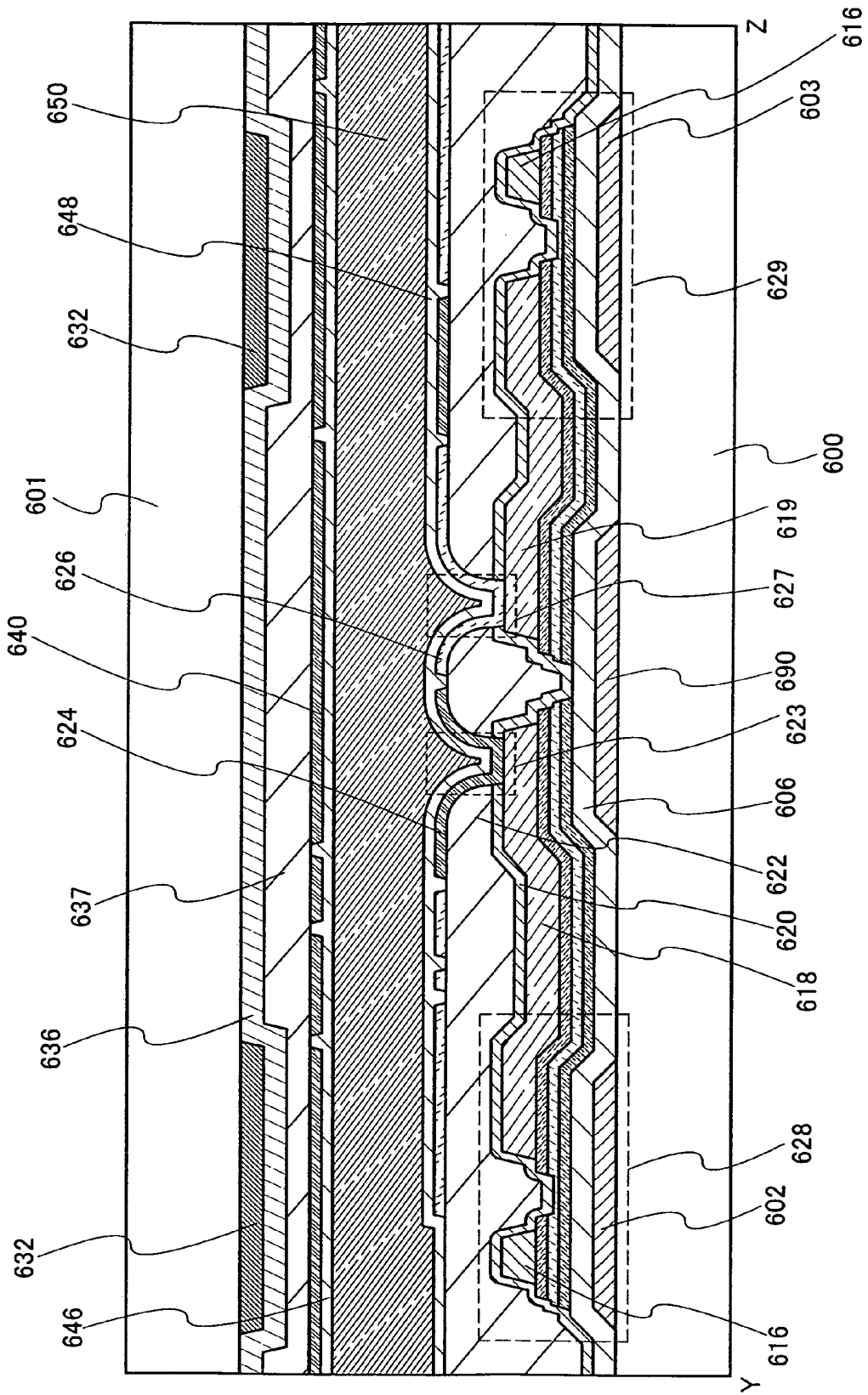

FIG. 20

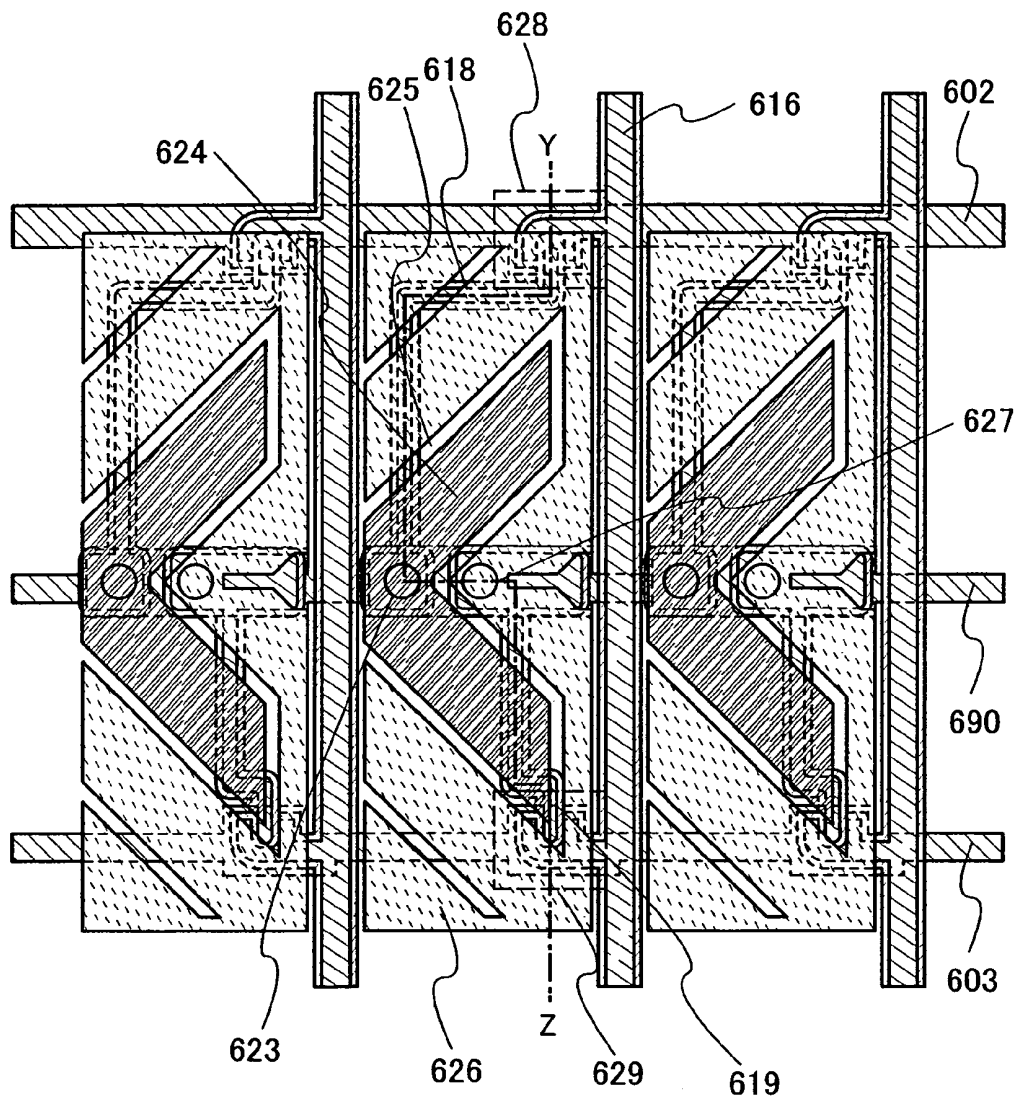

FIG. 21

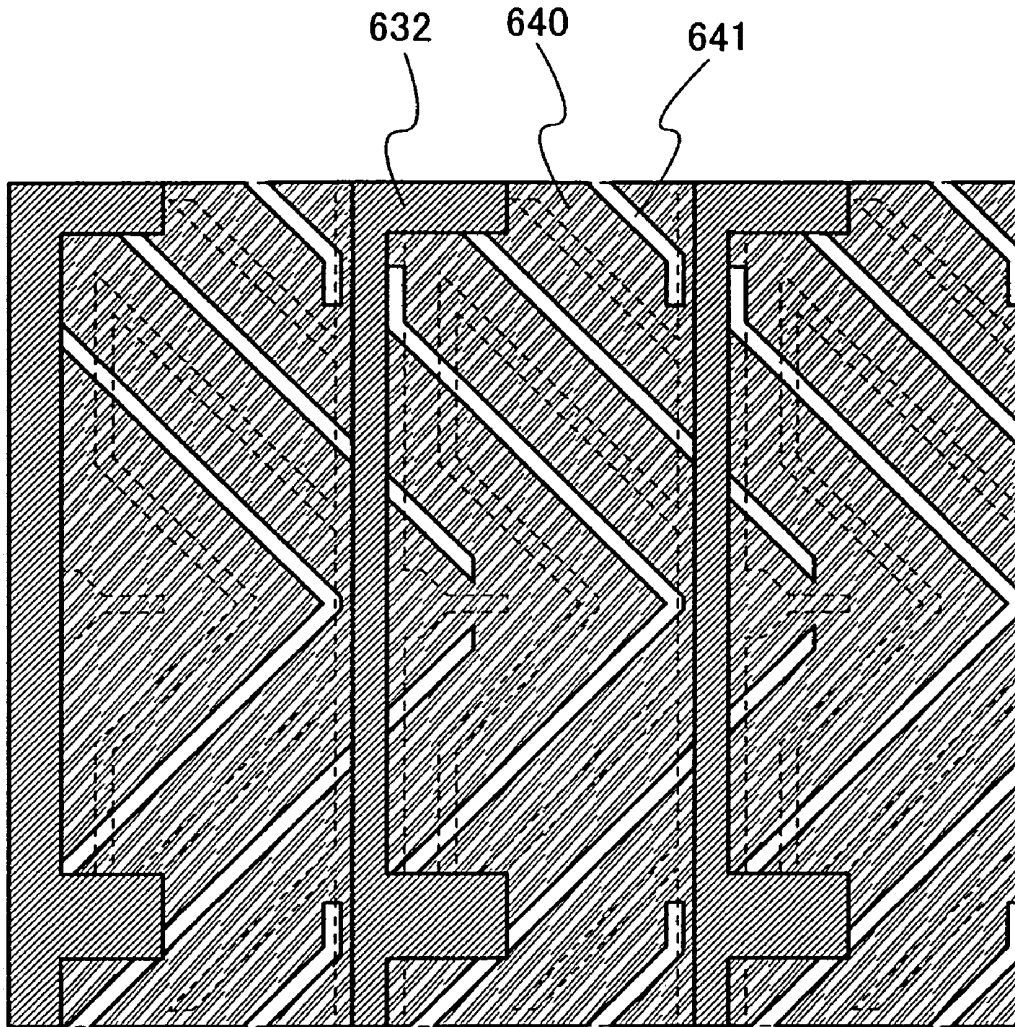

FIG. 22

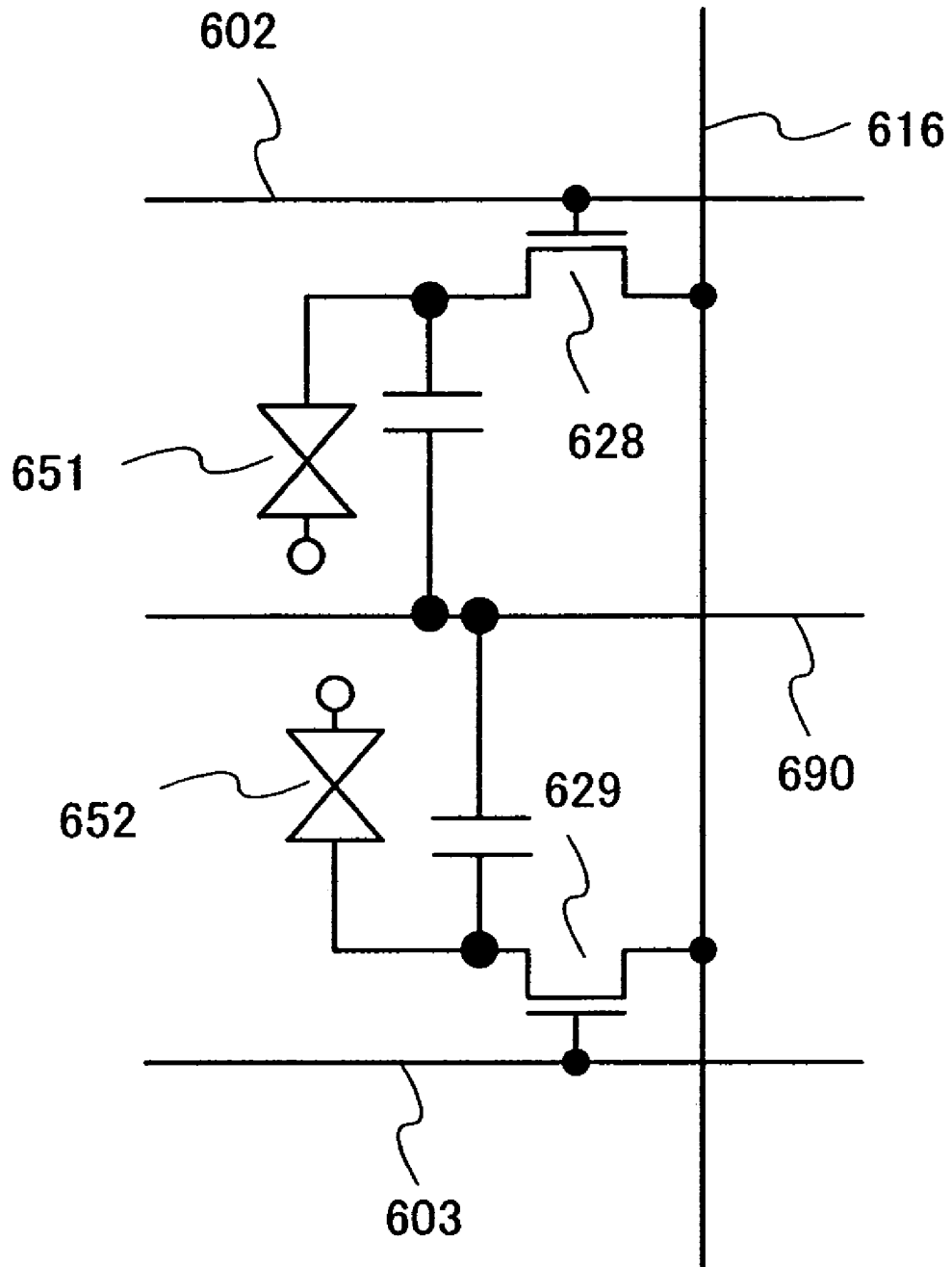

FIG. 23

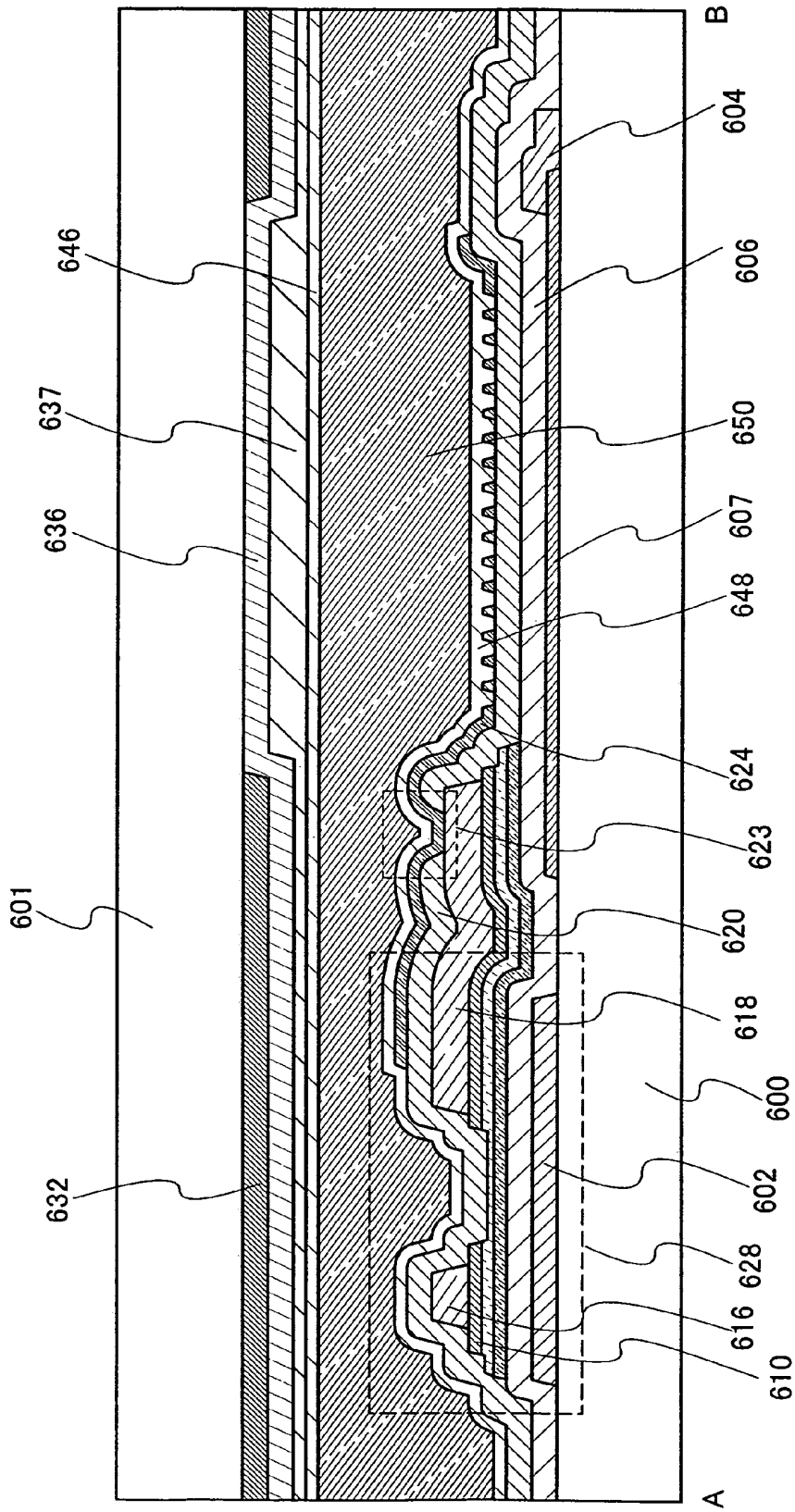

FIG. 24

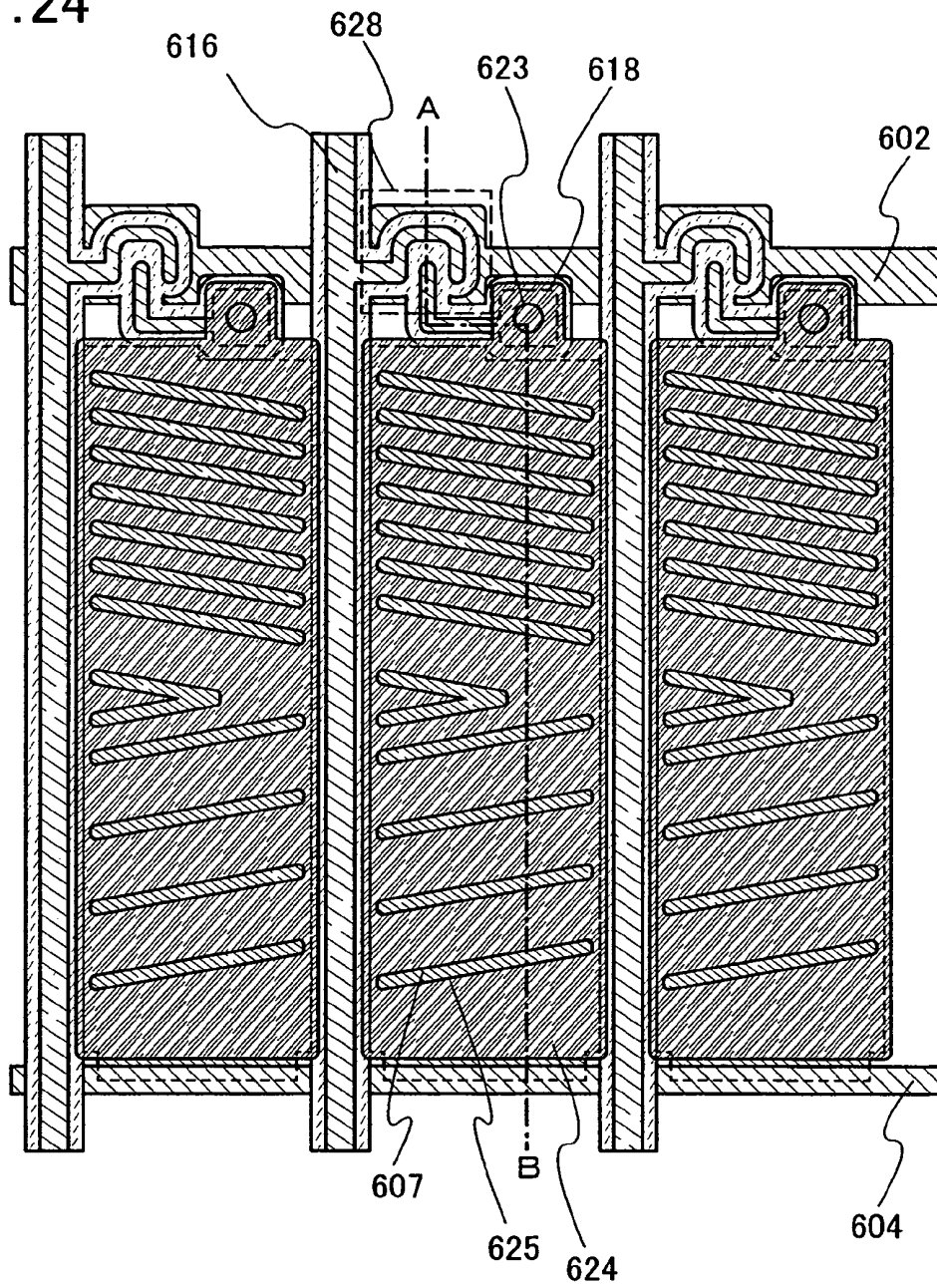

FIG. 25

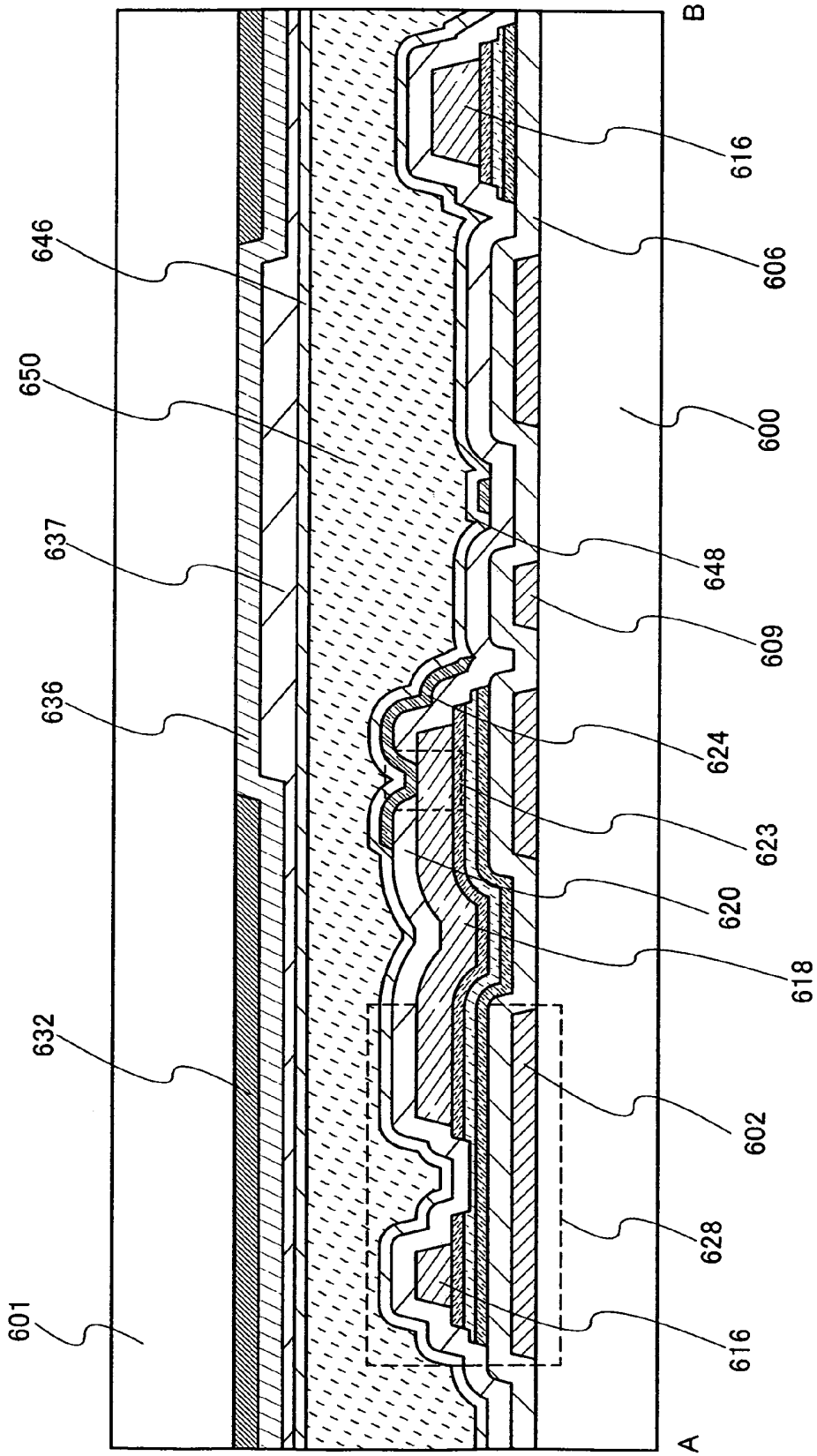

FIG. 26

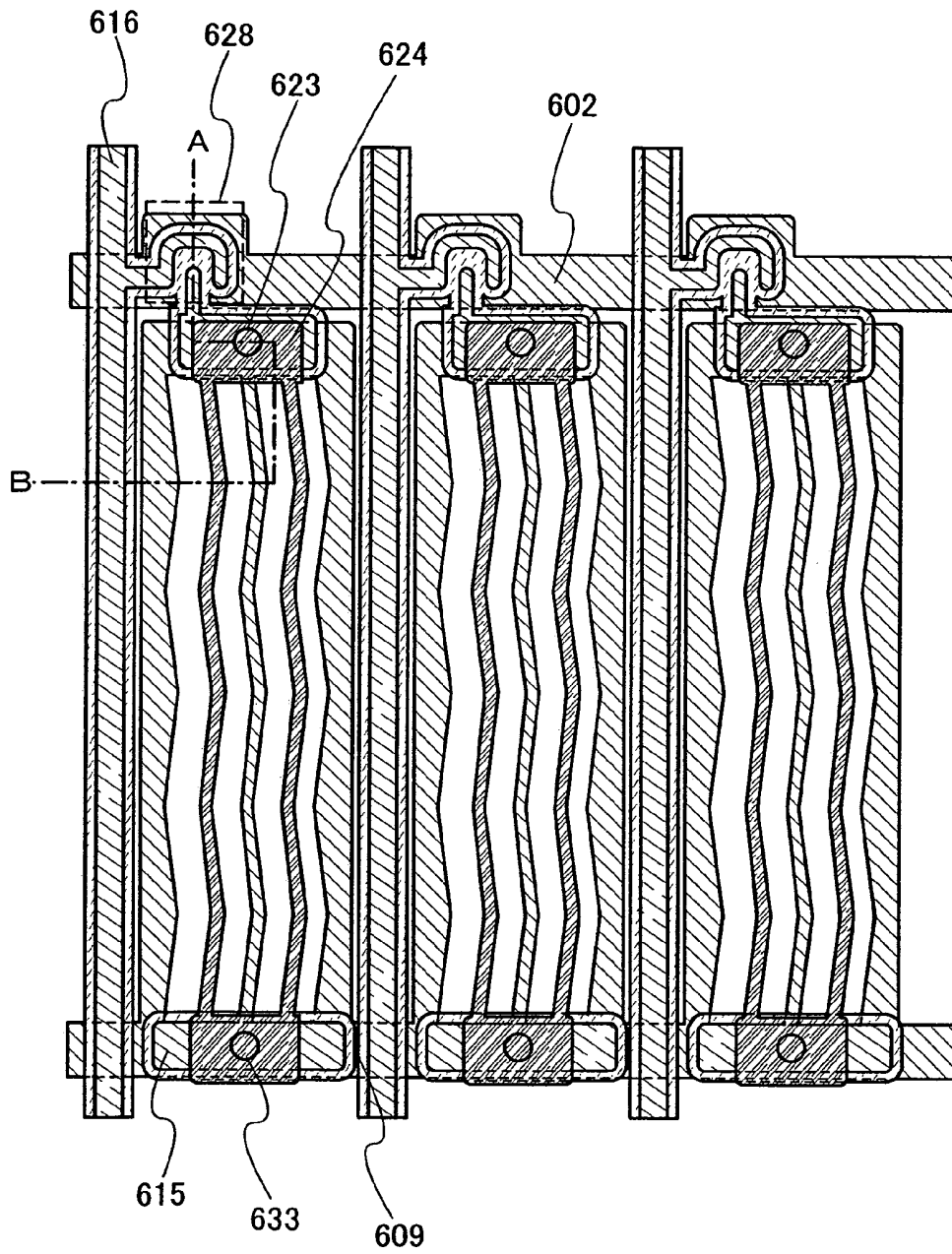

FIG. 27

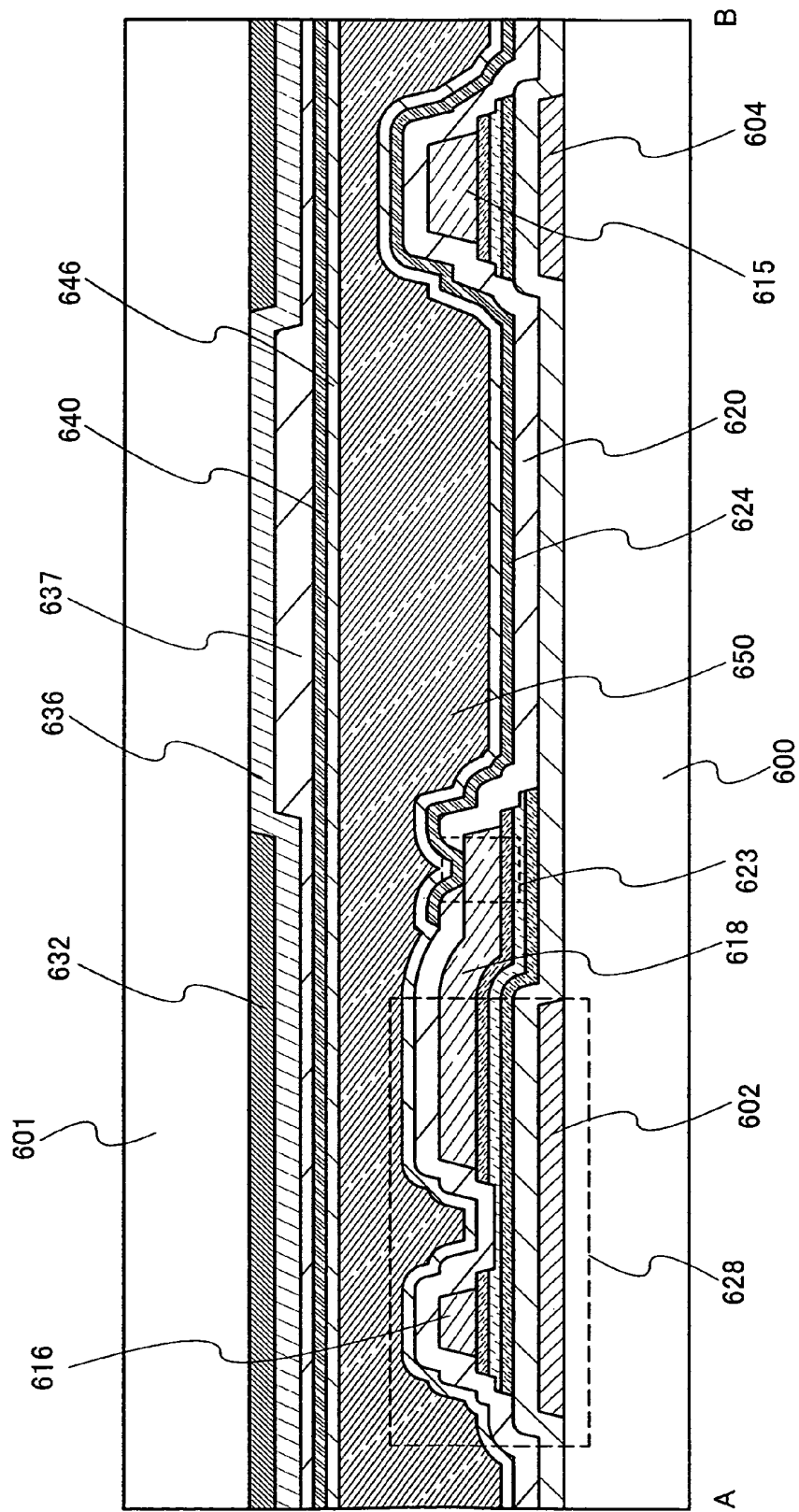

FIG. 28

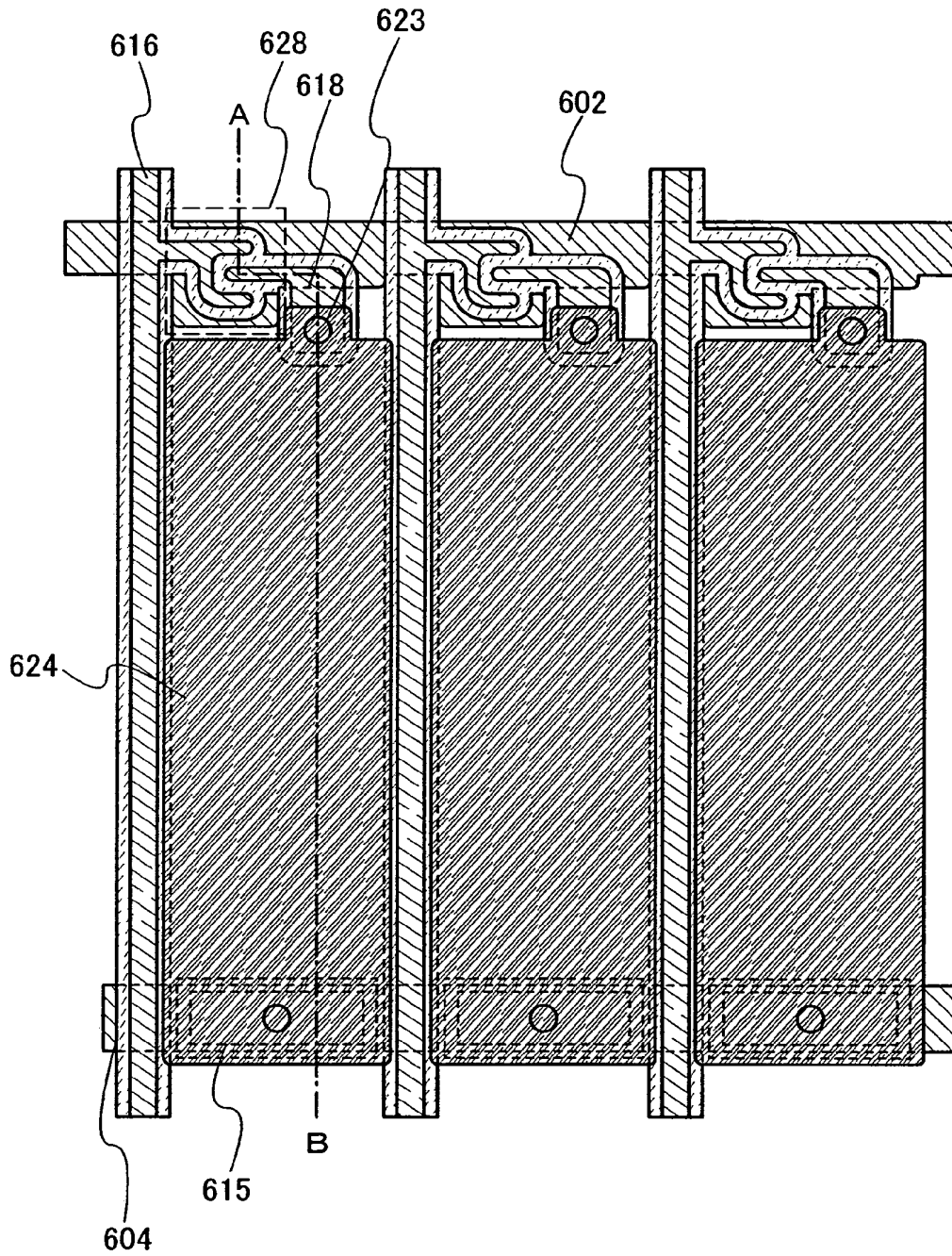

FIG. 29A

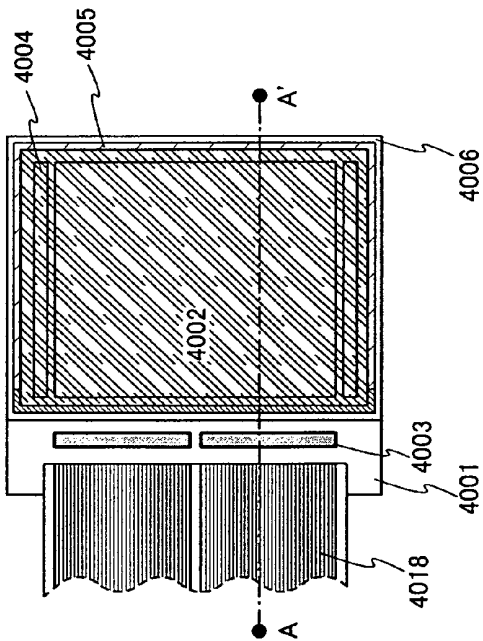

FIG. 29B

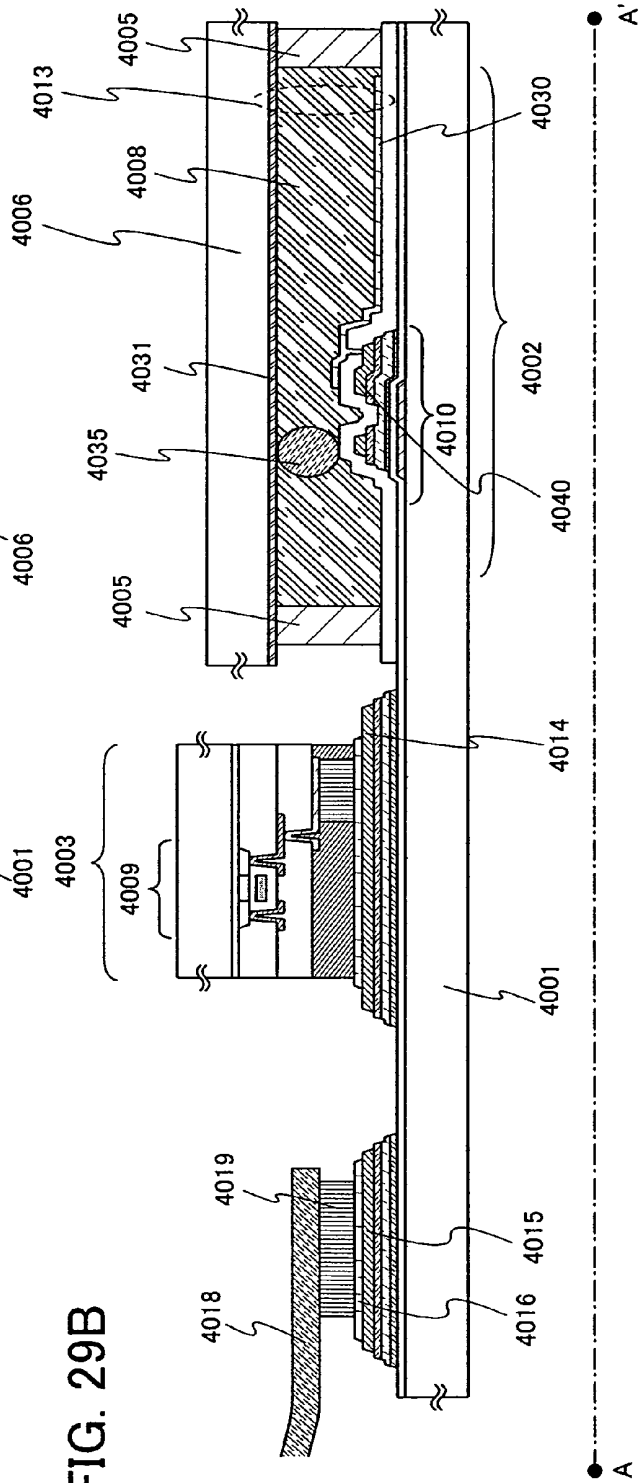

FIG. 30

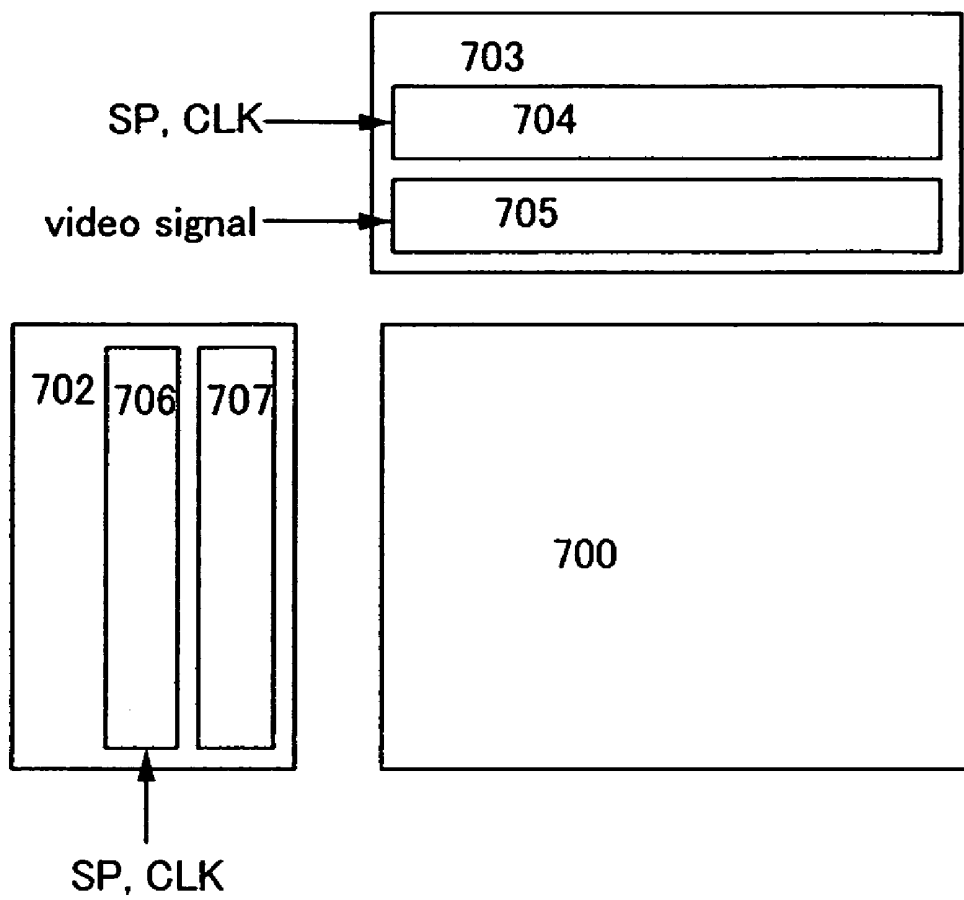

FIG. 31

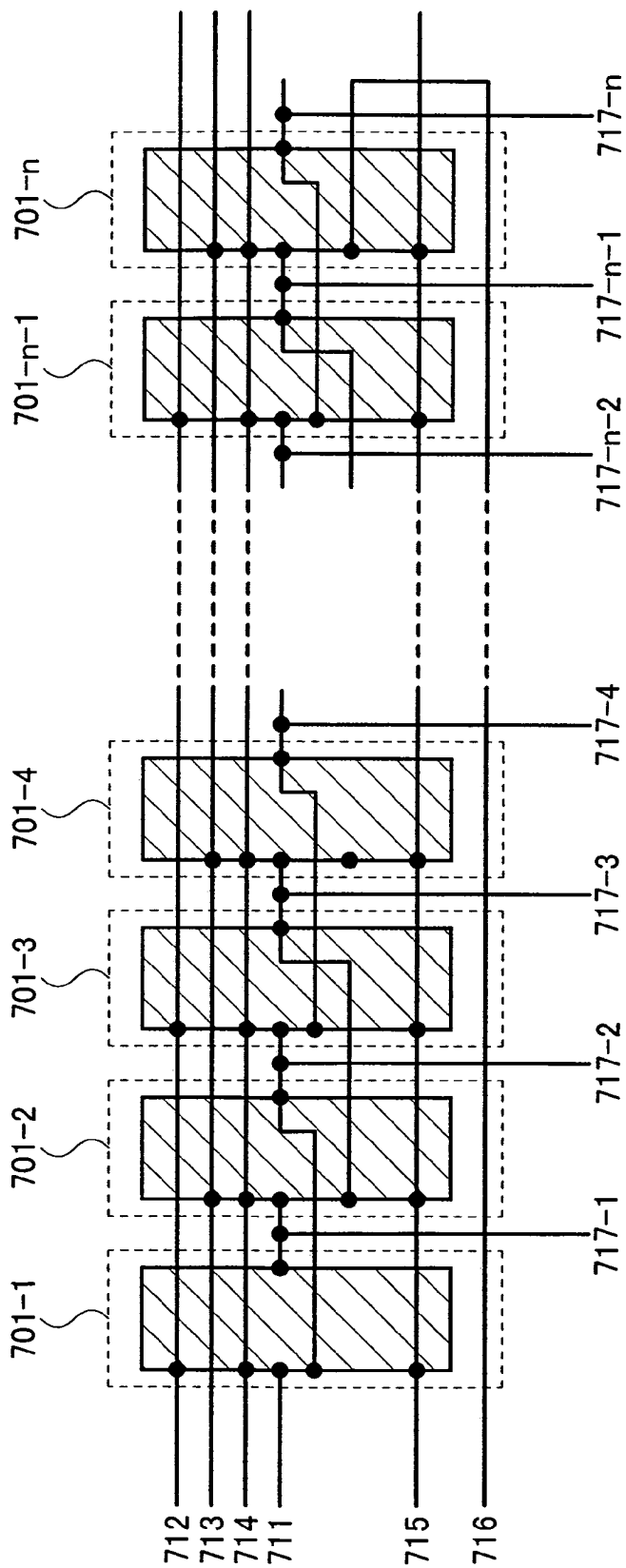
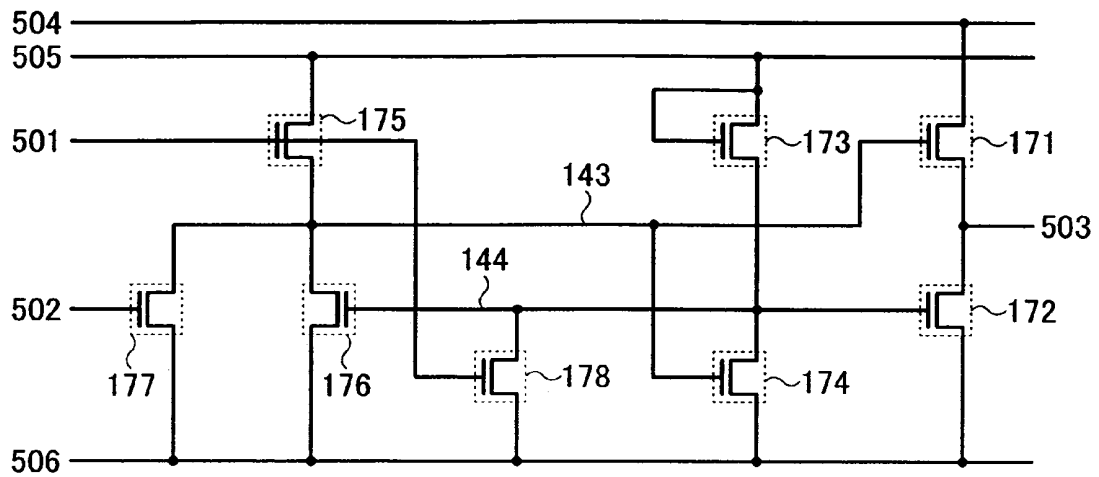

FIG. 32



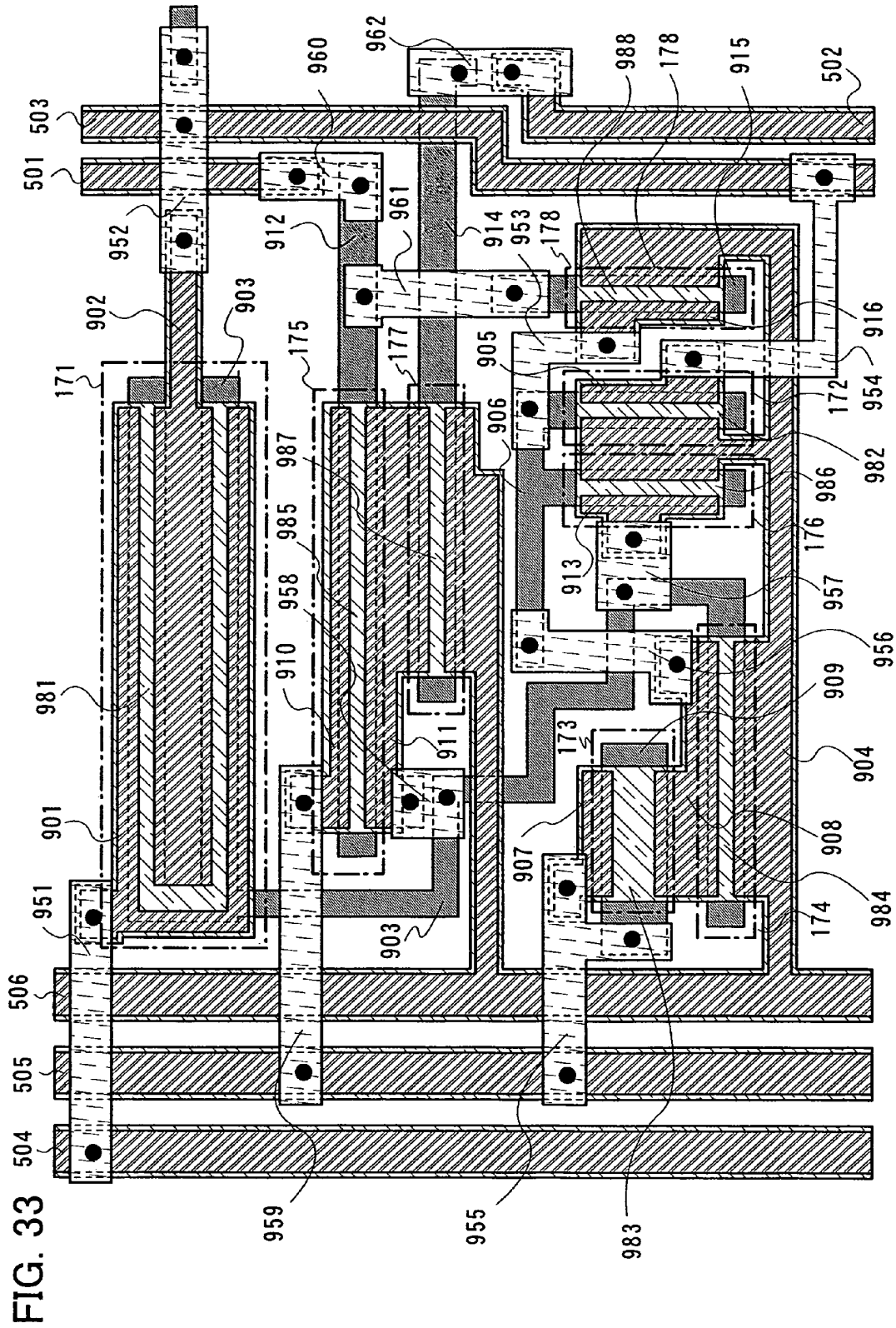

FIG. 34A

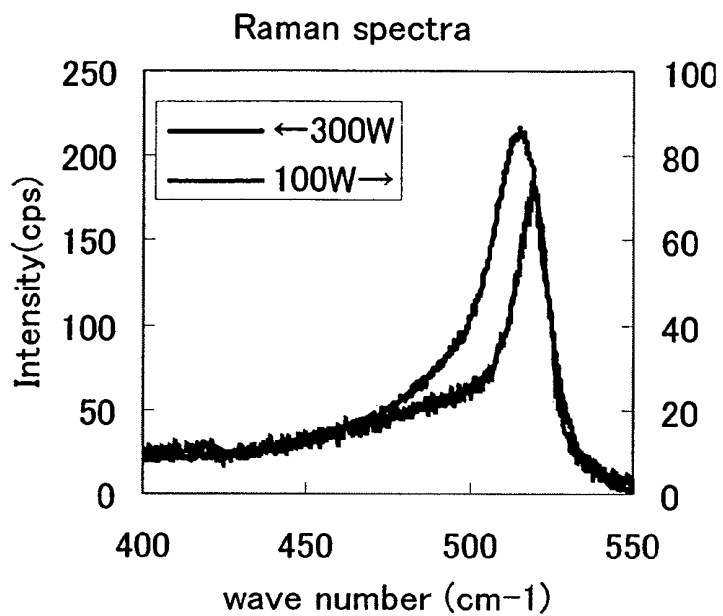

FIG. 34B

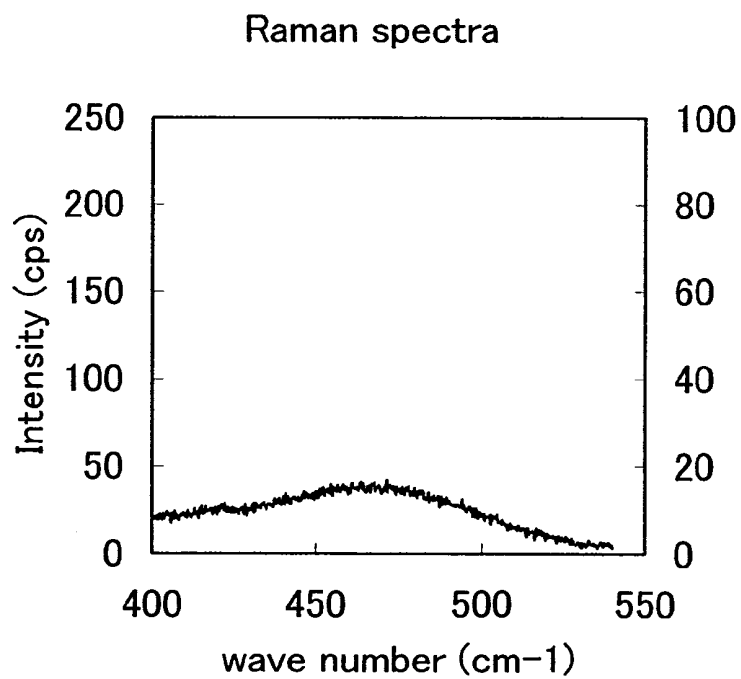

FIG. 35

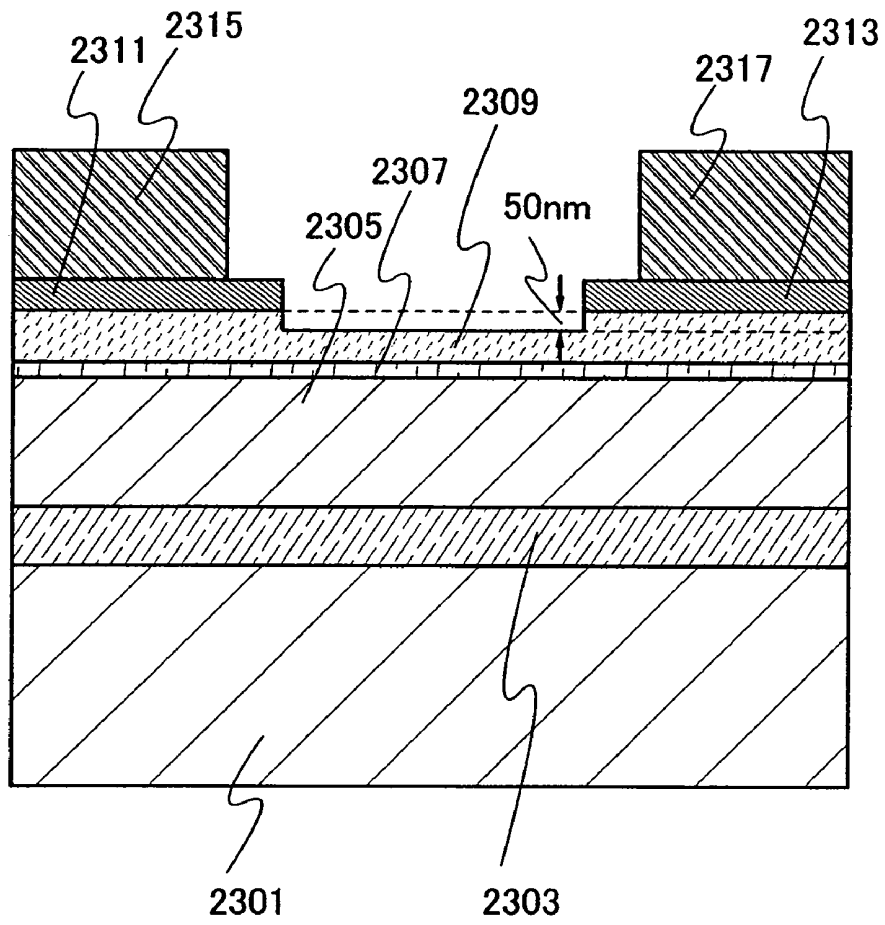

FIG. 36

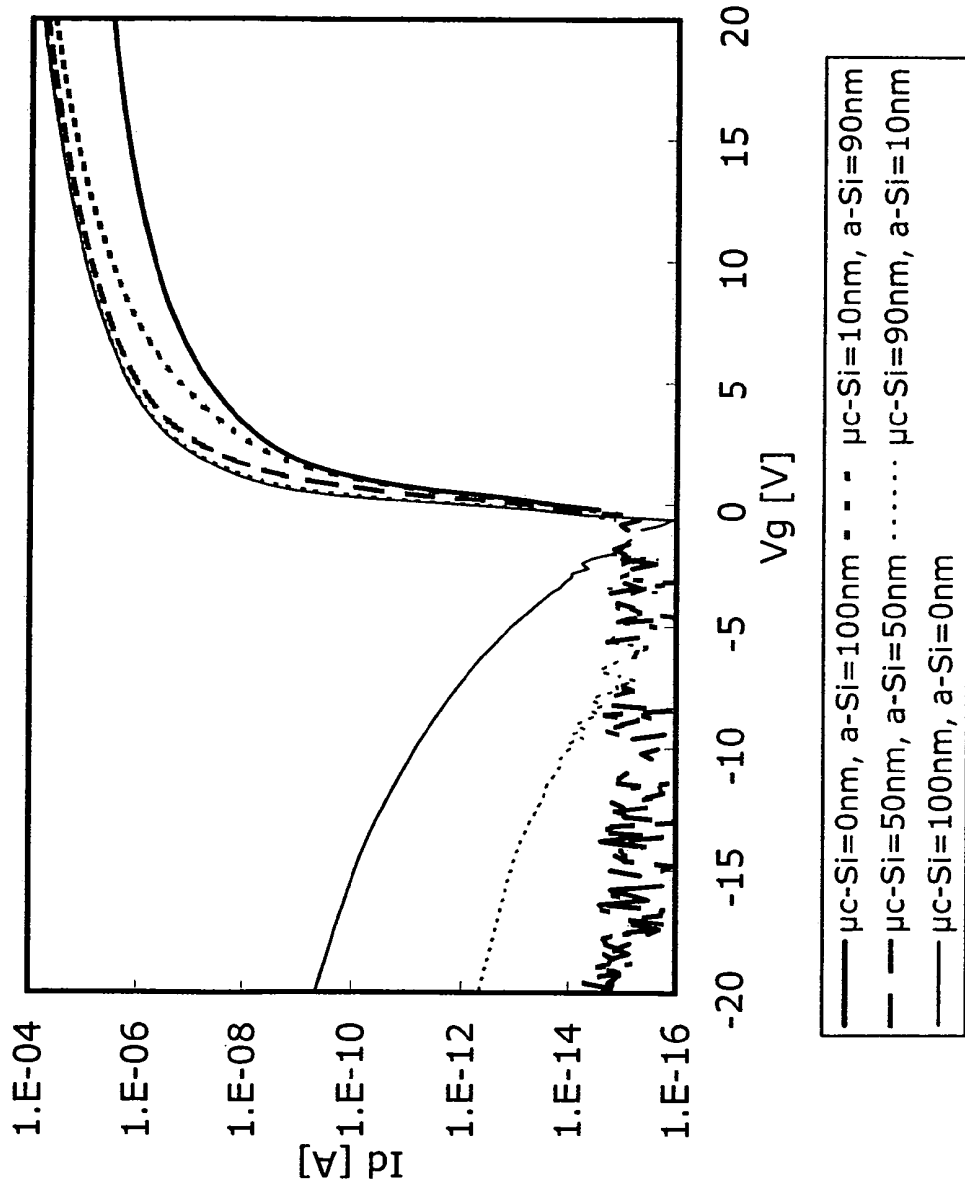

FIG. 37A

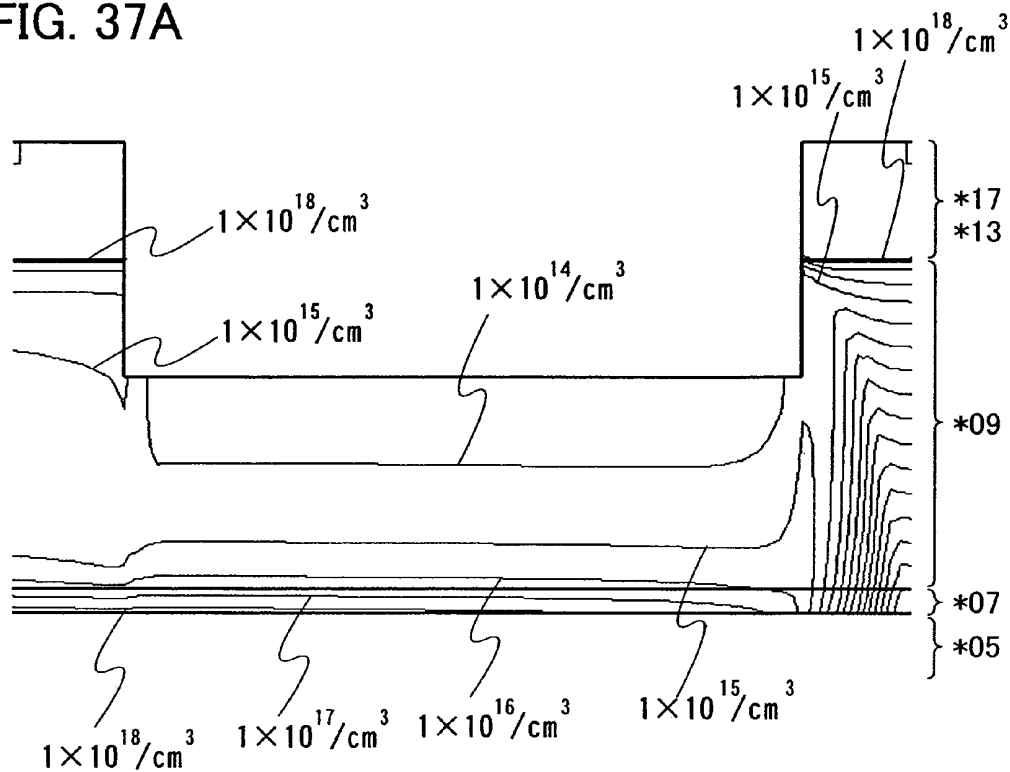
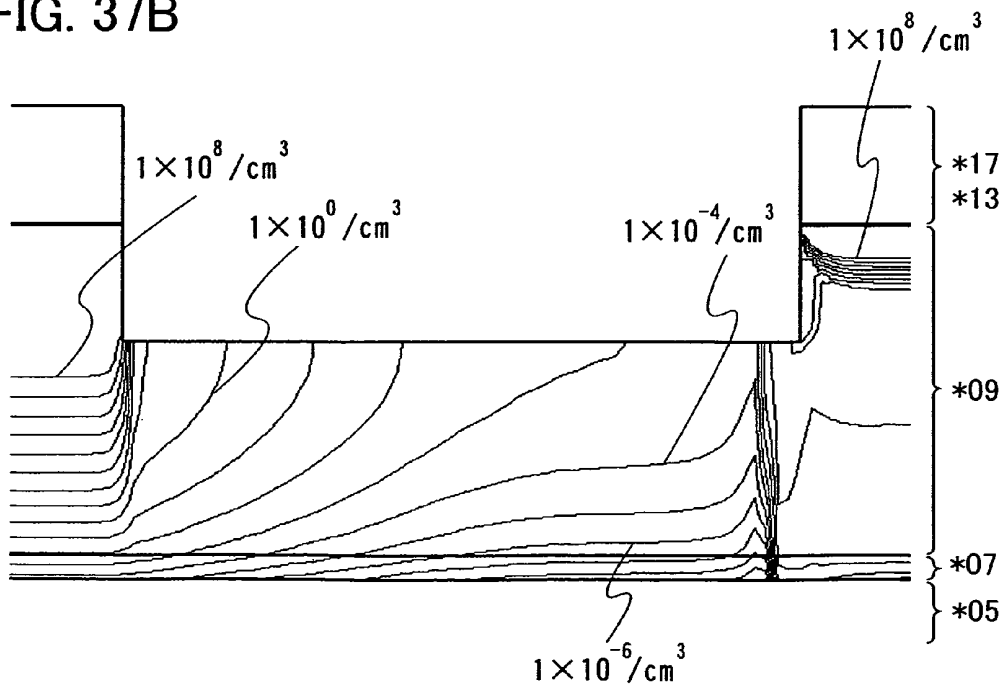

FIG. 37B



## LIQUID CRYSTAL DISPLAY DEVICE

## BACKGROUND OF THE INVENTION

## 1. Field of the Invention

The present invention relates to a liquid crystal display device using a thin film transistor at least in a pixel portion.

## 2. Description of the Related Art

In recent years, techniques to form thin film transistors using, for a channel formation region, a semiconductor thin film (with a thickness of approximately several tens to several hundreds of nanometers) which is formed over a substrate having an insulating surface have attracted attention. Thin film transistors are widely used in electronic devices such as ICs and electro-optical devices, and their development especially as switching elements for image display devices has been accelerated.

As a switching element of an image display device, a thin film transistor using an amorphous semiconductor film for a channel formation region, a thin film transistor using a polycrystalline semiconductor film for a channel formation region, and the like are known. As a method of forming a polycrystalline semiconductor film, there is known a technique in which a pulsed excimer laser beam is shaped into a linear laser beam by an optical system and an amorphous silicon film is crystallized by being irradiated while being scanned with the linear laser beam.

As a switching element of an image display device, a thin film transistor using a microcrystalline semiconductor film for a channel formation region is also used (see References 1 and 2).

[Reference 1] Japanese Published Patent Application No. H4-242724

[Reference 2] Japanese Published Patent Application No. 2005-49832

## SUMMARY OF THE INVENTION

A thin film transistor using a polycrystalline semiconductor film for a channel formation region has advantages in that its field-effect mobility is two or more orders of magnitude greater than that of a thin film transistor using an amorphous semiconductor film for a channel formation region and a pixel portion of a semiconductor display device and peripheral driver circuits thereof can be formed over the same substrate. However, the process of the thin film transistor using a polycrystalline semiconductor film for a channel formation region is more complex than a thin film transistor using an amorphous semiconductor film for a channel formation region, because crystallization of a semiconductor film provided over a glass substrate is added; accordingly, there are problems in that yield is decreased and cost is increased.

There is also a problem in that surfaces of crystal grains of a microcrystalline semiconductor film are easily oxidized. Therefore, when crystal grains in a channel formation region are oxidized, oxide films are formed on the surfaces of the crystal grains and the oxide films become obstacles to carrier transfer, which causes a problem in that electric characteristics of a thin film transistor are impaired.

In view of the above-mentioned problems, it is an object of the present invention to provide liquid crystal display devices having highly reliable thin film transistors with good electric characteristics and a method for manufacturing the liquid crystal display devices with high mass productivity.

In a liquid crystal display device having an inverted staggered thin film transistor, the inverted staggered thin film

transistor is formed as follows: a gate insulating film is formed over a gate electrode; a microcrystalline semiconductor film (also referred to as a semi-amorphous semiconductor film) which functions as a channel formation region is formed over the gate insulating film; a buffer layer is formed over the microcrystalline semiconductor film; a pair of source and drain regions are formed over the buffer layer; and a pair of source and drain electrodes are formed in contact with the source and drain regions so as to expose parts of the source and drain regions. Thus, the source and drain regions include regions that are in contact with the source and drain electrodes and regions that are not in contact with the source and drain electrodes. Outside the source and drain electrodes, parts of the source and drain regions and a part of the buffer layer are exposed. The source and drain electrodes are not overlapped with end portions of the microcrystalline semiconductor film and the source and drain regions. Outside end portions of the source and drain electrodes, end portions of the source and drain regions and the buffer layer are formed.

Due to misalignment of the end portions of the source and drain electrodes with the end portions of the source and drain regions, and due to formation of the end portions of the source and drain regions outside the end portions of the source and drain electrodes, the end portions of the source and drain electrodes are apart from each other; accordingly, leakage current and short circuit between the source and drain electrodes can be prevented. In addition, an electric field can be prevented from being concentrated on the end portions of the source and drain electrodes and the source and drain regions, and leakage current between the gate electrode and the source and drain electrodes can be prevented.

The buffer layer has a concave portion in its part, and the side of the concave portion is aligned with the end portions of the source and drain regions. Because the buffer layer has a concave in its part, the length between the source and drain regions is long, and thus the length of a path of carriers transfer is long, leakage current between the source and drain regions can be reduced.

Between the microcrystalline semiconductor film and the source and drain regions, the buffer layer is formed. The microcrystalline semiconductor film functions as a channel formation region. The buffer layer functions as a high-resistance region as well as preventing the microcrystalline semiconductor film from being oxidized. Because the buffer layer is formed using an amorphous semiconductor film having high resistance between the microcrystalline semiconductor film and the source and drain regions, field-effect mobility of a thin film transistor of the present invention is high, leakage current is low, and drain withstand voltage is high in the case of an off state (when a negative voltage is applied to a gate electrode).

As the buffer layer, an amorphous semiconductor film can be used, and moreover, it is preferable that the buffer layer be an amorphous semiconductor film containing at least any one of nitrogen, hydrogen, and halogen. When an amorphous semiconductor film is made to contain any one of nitrogen, hydrogen, and halogen, crystal grains contained in the microcrystalline semiconductor film can be further prevented from being oxidized.

The buffer layer can be formed by a plasma CVD method, a sputtering method, or the like. In addition, after an amorphous semiconductor film is formed, the amorphous semiconductor film was subjected to nitrogen plasma, hydrogen plasma, or halogen plasma so that the amorphous semiconductor film can be nitrided, hydrogenated or halogenated.

By provision of the buffer layer over the surface of the microcrystalline semiconductor film, oxidation of crystal

grains contained in the microcrystalline semiconductor film can be reduced. Accordingly, the degree of degradation of electric characteristics of a thin film transistor can be lowered.

Unlike a polycrystalline semiconductor film, a microcrystalline semiconductor film can be directly formed over a substrate as a microcrystalline semiconductor film. Specifically, a microcrystalline semiconductor film can be formed using silicon hydride as a source gas and using a plasma CVD apparatus. The microcrystalline semiconductor film manufactured by the above method includes a microcrystalline semiconductor film which contains crystal grains of 0.5 nm to 20 nm in an amorphous semiconductor. Thus, unlike in the case of using a polycrystalline semiconductor film, there is no need to conduct a crystallization process after formation of a semiconductor film. The number of steps in manufacture of a thin film transistor can be reduced; yield of a liquid crystal display device can be increased; and cost can be lowered. Plasma using a microwave with a frequency of 1 GHz or more has high electron density, which facilitates dissociation of silicon hydride that is a source gas. Therefore, compared to a microwave plasma CVD method with a frequency of several tens to several hundreds of megahertz, the microcrystalline semiconductor film can be formed more easily and deposition rate can be increased, by a plasma CVD method using a microwave with a frequency of 1 GHz or higher. Thus, the mass productivity of liquid crystal display devices can be increased.

In addition, thin film transistors (TFTs) are formed using a microcrystalline semiconductor film, and a liquid crystal display device is manufactured using the thin film transistors in a pixel portion and also in driver circuits. Because thin film transistors using a microcrystalline semiconductor film each have a field-effect mobility of  $1 \text{ cm}^2/\text{V}\cdot\text{sec}$  to  $20 \text{ cm}^2/\text{V}\cdot\text{sec}$ , which is 2 to 20 times greater than that of a thin film transistor using an amorphous semiconductor film for its channel forming region, some of or all of the driver circuits can be formed over the same substrate as the pixel portion to form a system-on-panel display.

In addition, a liquid crystal display device includes a liquid crystal element. Further, a liquid crystal display device includes a panel in which a liquid crystal is sealed, and a module in which an IC or the like including a controller is mounted to the panel. Moreover, the present invention relates to an element substrate which is a mode before completion of a liquid crystal element in a manufacturing process of the liquid crystal display device, and the element substrate includes a means for supplying voltage to a liquid crystal element in each of plural pixels. The element substrate may be specifically in a state where only a pixel electrode of a liquid crystal element is formed or in a state after a conductive film to be a pixel electrode is formed and before the conductive film is etched into a pixel electrode, and any mode is possible.

Note that the term "liquid crystal display device" in this specification refer to image display devices, the liquid crystal display devices and light sources (including lighting devices). In addition, liquid crystal display devices include all of the following modules: modules provided with a connector, for example, a flexible printed circuit (FPC), a tape automated bonding (TAB) tape, or a tape carrier package (TCP); modules provided with a printed wiring board at the end of a TAB tape or a TCP; and modules where an integrated circuit (IC) is directly mounted on a liquid crystal element by a chip-on-glass (COG) method.

According to the present invention, it is possible to manufacture, with high mass productivity, liquid crystal display devices having highly reliable thin film transistors with good electric characteristics.

## BRIEF DESCRIPTION OF THE DRAWINGS

FIGS. 1A and 1B are cross-sectional views showing a method for manufacturing a liquid crystal display device according to an aspect of the present invention;

FIGS. 2A to 2C are cross-sectional views showing a method for manufacturing a liquid crystal display device according to an aspect of the present invention;

FIGS. 3A and 3B are cross-sectional views showing a method for manufacturing a liquid crystal display device according to an aspect of the present invention;

FIGS. 4A and 4B are cross-sectional views showing a method for manufacturing a liquid crystal display device according to an aspect of the present invention;

FIGS. 5A to 5C are top views showing a method for manufacturing a liquid crystal display device according to an aspect of the present invention;

FIGS. 6A to 6C are cross-sectional views showing a method for manufacturing a liquid crystal display device according to an aspect of the present invention;

FIGS. 7A to 7C are cross-sectional views showing a method for manufacturing a liquid crystal display device according to an aspect of the present invention;

FIGS. 8A and 8B are cross-sectional views showing a method for manufacturing a liquid crystal display device according to an aspect of the present invention;

FIGS. 9A to 9D are top views showing a method for manufacturing a liquid crystal display device according to an aspect of the present invention;

FIG. 10 is a top view showing a microwave plasma CVD apparatus according to an aspect of the present invention;

FIGS. 11A to 11D are cross-sectional views showing multi-tone masks which can be applied to the present invention;

FIGS. 12A to 12C are perspective views showing liquid crystal display panels according to an aspect of the present invention;

FIGS. 13A to 13C are perspective views showing electronic devices each using a liquid crystal display device according to an aspect of the present invention;

FIG. 14 is a diagram showing an electronic device using a liquid crystal display device according to an aspect of the present invention;

FIG. 15 is a diagram showing a liquid crystal display device according to an aspect of the present invention;

FIG. 16 is a diagram showing a liquid crystal display device according to an aspect of the present invention;

FIG. 17 is a diagram showing a liquid crystal display device according to an aspect of the present invention;

FIG. 18 is a diagram showing a liquid crystal display device according to an aspect of the present invention;

FIG. 19 is a diagram showing a liquid crystal display device according to an aspect of the present invention;

FIG. 20 is a diagram showing a liquid crystal display device according to an aspect of the present invention;

FIG. 21 is a diagram showing a liquid crystal display device according to an aspect of the present invention;

FIG. 22 is a diagram showing a liquid crystal display device according to an aspect of the present invention;

FIG. 23 is a diagram showing a liquid crystal display device according to an aspect of the present invention;

FIG. 24 is a diagram showing a liquid crystal display device according to an aspect of the present invention;

FIG. 25 is a diagram showing a liquid crystal display device according to an aspect of the present invention;

FIG. 26 is a diagram showing a liquid crystal display device according to an aspect of the present invention;

FIG. 27 is a diagram showing a liquid crystal display device according to an aspect of the present invention;

FIG. 28 is a diagram showing a liquid crystal display device according to an aspect of the present invention;

FIGS. 29A and 29B are a top view and a cross-sectional view showing a liquid crystal display panel according to an aspect of the present invention, respectively;

FIG. 30 is a block diagram showing a structure of a liquid crystal display device according to an aspect of the present invention;

FIG. 31 is an equivalent circuit diagram showing a structure of a driver circuit of a liquid crystal display device according to an aspect of the present invention;

FIG. 32 is an equivalent circuit diagram showing a structure of a driver circuit of a liquid crystal display device according to an aspect of the present invention;

FIG. 33 is a top view showing a layout of a driver circuit of a liquid crystal display device according to an aspect of the present invention;

FIGS. 34A and 34B are diagrams showing results of measurement of a microcrystalline semiconductor film by Raman spectroscopy;

FIG. 35 is a model diagram showing a device structure used for device simulation;

FIG. 36 is a graph showing current-voltage characteristics by device simulation; and

FIGS. 37A and 37B are diagrams each showing an electron concentration distribution of a thin film transistor obtained by device simulation.

#### DETAILED DESCRIPTION OF THE INVENTION

Embodiment modes of the present invention will be hereinafter described with reference to the drawings. However, the present invention can be carried out in many different modes, and it is easily understood by those skilled in the art that the mode and detail of the present invention can be modified in various ways without departing from the spirit and scope thereof. Therefore, the present invention should not be interpreted as being limited to the description in the following embodiment modes.

##### Embodiment Mode 1

In this embodiment mode, manufacturing processes of thin film transistors used for a liquid crystal display device are described with reference to FIGS. 1A, 1B, FIGS. 2A to 2C, FIGS. 3A, 3B, FIGS. 4A, 4B, FIGS. 5A to 5C, FIGS. 6A to 6C, FIGS. 7A to 7C, FIGS. 8A, 8B, FIGS. 9A to 9D, FIG. 10, FIGS. 11A to 11D, and FIGS. 12A to 12C. FIGS. 1A, 1B, FIGS. 2A to 2C, FIGS. 3A, 3B, and FIGS. 4A, 4B and FIGS. 6A to 6C, FIGS. 8A, 8B are cross-sectional views showing manufacturing processes of thin film transistors, and FIGS. 5A to 5C and FIGS. 9A to 9D are top views each showing a connection region of a thin film transistor and a pixel electrode in a single pixel.

An n-channel thin film transistor having a microcrystalline semiconductor film is more suitable for use in a driver circuit than that of a p-channel thin film transistor having a microcrystalline semiconductor film, because the n-channel one has a higher field-effect mobility. It is desired that all thin film transistors formed over the same substrate have the same polarity, in order to reduce the number of steps. Here, description is made using an n-channel thin film transistor.

As illustrated in FIG. 1A, a gate electrode 51 is formed over a substrate 50. As the substrate 50, any of the following substrates can be used: non-alkaline glass substrates made of

barium borosilicate glass, aluminoborosilicate glass, aluminosilicate glass, and the like by a fusion method or a float method; ceramic substrates; plastic substrates having heat resistance enough to withstand a process temperature of this manufacturing process; and the like. Alternatively, metal substrates of a stainless alloy and the like with the surface provided with an insulating film may be employed. When the substrate 50 is mother glass, the substrate may have any of the following sizes: the first generation (320 mm×400 mm), the second generation (400 mm×500 mm), the third generation (550 mm×650 mm), the fourth generation (680 mm×880 mm, or 730 mm×920 mm), the fifth generation (1000 mm×1200 mm, or 1100 mm×1250 mm), the sixth generation (1500 mm×1800 mm), the seventh generation (1900 mm×2200 mm), the eighth generation (2160 mm×2460 mm), the ninth generation (2400 mm×2800 mm, or 2450 mm×3050 mm), the tenth generation (2950 mm×3400 mm), and the like.

The gate electrode 51 is formed using a metal material such as titanium, molybdenum, chromium, tantalum, tungsten, or aluminum or an alloy material thereof. The gate electrode 51 can be formed in such a manner that a conductive film is formed over the substrate 50 by a sputtering method or a vacuum evaporation method; a mask is formed over the conductive film by a photolithography technique or an inkjet method; and the conductive film is etched using the mask. Note that, as barrier metal which increases adhesion of the gate electrode 51 and prevents diffusion to a base, a nitride film of the above-mentioned metal material may be provided between the substrate 50 and the gate electrode 51. Here, the gate electrode 51 is formed by etching of the conductive film formed over the substrate 50 with use of a resist mask formed using a first photomask.

Note that, because an insulating film, a semiconductor film, a wiring and the like are to be formed over the gate electrode 51, it is desired that the gate electrode 51 be processed so as to have tapered end portions in order to prevent disconnection. In addition, although not shown, in this step, a wiring connected to the gate electrode can also be formed at the same time.

Next, over the gate electrode 51, gate insulating films 52a and 52b, a microcrystalline semiconductor film 53, a buffer layer 54, a semiconductor film 55 to which an impurity element imparting one conductivity type is added, and conductive films 65a to 65c are formed in this order. Then, a resist 80 is applied over the conductive film 65c. Note that it is preferable that at least the gate insulating films 52a and 52b, the microcrystalline semiconductor film 53, and the buffer layer 54 be formed successively. It is further preferable that the gate insulating films 52a and 52b, the microcrystalline semiconductor film 53, the buffer layer 54, and the semiconductor film 55 to which an impurity element imparting one conductivity type is added be formed successively. By successive formation of at least the gate insulating films 52a and 52b, the microcrystalline semiconductor film 53, and the buffer layer 54 without any exposure to the atmosphere, each interface between stacked layers can be formed without being contaminated by an atmospheric constituent or a contaminant impurity element floating in the atmosphere. Thus, variations in characteristics of thin film transistors can be reduced.

The gate insulating films 52a and 52b can each be formed by a CVD method, a sputtering method, or the like using a silicon oxide film, a silicon nitride film, a silicon oxynitride film, or a silicon nitride oxide film. Here, a mode is described in which a silicon oxide film or a silicon oxynitride film, and a silicon nitride film or a silicon nitride oxide film are stacked in this order as the gate insulating films 52a and 52b. Note that the gate insulating film can be formed by stacking not two

layers but three layers of a silicon nitride film or a silicon nitride oxide film, a silicon oxide film or a silicon oxynitride film, and a silicon nitride film or a silicon nitride oxide film in this order from the substrate side. Alternatively, the gate insulating film can be formed of a single layer of a silicon oxide film, a silicon nitride film, a silicon oxynitride film, or a silicon nitride oxide film.

Note that a silicon oxynitride film means a film that contains more oxygen than nitrogen and, in the case where measurements are performed using Rutherford backscattering spectrometry (RBS) and hydrogen forward scattering (HFS), includes oxygen, nitrogen, silicon, and hydrogen at concentrations ranging from 50 at. % to 70 at. %, 0.5 at. % to 15 at. %, 25 at. % to 35 at. %, and 0.1 at. % to 10 at. %, respectively. Further, a silicon nitride oxide film means a film that contains more nitrogen than oxygen and, in the case where measurements are performed using RBS and HFS, includes oxygen, nitrogen, silicon, and hydrogen at concentrations ranging from 5 at. % to 30 at. %, 20 at. % to 55 at. %, 25 at. % to 35 at. %, and 10 at. % to 30 at. %, respectively. Note that percentages of nitrogen, oxygen, silicon, and hydrogen fall within the ranges given above, where the total number of atoms contained in the silicon oxynitride film or the silicon nitride oxide film is defined as 100 at. %.

The microcrystalline semiconductor film **53** is a film which contains a semiconductor having an intermediate structure between amorphous and crystalline structures (including a single crystal and a polycrystal). This semiconductor is a semiconductor which has a third state that is stable in terms of free energy, and is a crystalline semiconductor which has short-range order and lattice distortion, and column-like or needle-like crystals with its grains with a size of 0.5 nm to 20 nm grown in the direction of a normal line with respect to the surface of the substrate. In addition, a microcrystalline semiconductor and an amorphous semiconductor are mixed. Microcrystalline silicon, which is a typical example of a microcrystalline semiconductor, has a Raman spectrum which is shifted to a lower wave number side than  $521\text{ cm}^{-1}$  that is a feature of single crystalline silicon. That is, the peak of a Raman spectrum of microcrystalline silicon is within the range from  $481\text{ cm}^{-1}$  to  $521\text{ cm}^{-1}$ , which features of amorphous silicon and single crystalline silicon respectively. In addition, microcrystalline silicon is made to contain hydrogen or halogen of at least 1 at. % or more for termination of dangling bonds. Moreover, microcrystalline silicon is made to contain a rare gas element such as helium, argon, krypton, or neon to further enhance its lattice distortion, whereby stability is increased and a favorable microcrystalline semiconductor film can be obtained. Such a microcrystalline semiconductor film is disclosed in, for example, U.S. Pat. No. 4,409,134.

The microcrystalline semiconductor film can be formed by a high-frequency plasma CVD method with a frequency of several tens to several hundreds of megahertz or a microwave plasma CVD apparatus with a frequency of 1 GHz or more. The microcrystalline semiconductor film can be typically formed using silicon hydride, such as  $\text{SiH}_4$  or  $\text{Si}_2\text{H}_6$ , which is diluted with hydrogen. With a dilution with one or plural kinds of rare gas elements of helium, argon, krypton, and neon in addition to silicon hydride and hydrogen, the microcrystalline semiconductor film can be formed. In that case, the flow rate ratio of hydrogen to silicon hydride is set to be 50:1 to 1000:1, preferably, 50:1 to 200:1, more preferably, 100:1. Note that, in place of silicon hydride,  $\text{SiH}_2\text{Cl}_2$ ,  $\text{SiHCl}_3$ ,  $\text{SiCl}_4$ ,  $\text{SiF}_4$ , or the like can be used.

A microcrystalline semiconductor film exhibits weak n-type conductivity when an impurity element for valence

control is not intentionally added. Thus, threshold control of a microcrystalline semiconductor film which functions as a channel formation region of a thin film transistor can be done by addition of an impurity element which imparts p-type conductivity at the same time as or after the film formation. A typical example of an impurity element which imparts p-type conductivity is boron, and an impurity gas such as  $\text{B}_2\text{H}_6$  or  $\text{BF}_3$  may be mixed into silicon hydride at a proportion of 1 ppm to 1000 ppm, preferably, 1 ppm to 100 ppm. The concentration of boron may be set to be, for example,  $1 \times 10^{14}$  atoms/ $\text{cm}^3$  to  $6 \times 10^{16}$  atoms/ $\text{cm}^3$ .

In addition, the oxygen concentration of the microcrystalline semiconductor film is preferably  $5 \times 10^{19}\text{ cm}^{-3}$  or less, more preferably,  $1 \times 10^{19}\text{ cm}^{-3}$  or less and each of the nitrogen concentration and the carbon concentration is preferably  $3 \times 10^{18}\text{ cm}^{-3}$  or less. By decreases in concentrations of oxygen, nitrogen, and carbon mixed into the microcrystalline semiconductor film, the microcrystalline semiconductor film can be prevented from being changed into an n type.

The microcrystalline semiconductor film **53** is formed to a thickness of greater than 0 nm and less than or equal to 200 nm, preferably, from 1 nm to 100 nm, more preferably, from 5 nm to 50 nm. The microcrystalline semiconductor film **53** functions as a channel formation region of a thin film transistor to be formed later. When the thickness of the microcrystalline semiconductor film **53** is within the range from 5 nm to 50 nm, inclusive, the thin film transistor to be formed later is to be a fully depleted type. In addition, because the deposition rate of the microcrystalline semiconductor film **53** is low, i.e., a tenth to a thousandth of the deposition rate of an amorphous semiconductor film, a decrease of thickness leads to an increase of throughput. Furthermore, because the microcrystalline semiconductor film contains microcrystals, it has a lower resistance than an amorphous semiconductor film. Therefore, a thin film transistor using the microcrystalline semiconductor film for its channel formation region has current-voltage characteristics represented by a curve with a steep slope in a rising portion, has an excellent response as a switching element, and can be operated at high speed. With the use of the microcrystalline semiconductor film in a channel formation region of a thin film transistor, fluctuation of a threshold voltage of a thin film transistor can be suppressed. Therefore, a liquid crystal display device with less variation of electrical characteristics can be manufactured.

The microcrystalline semiconductor film has a higher mobility than an amorphous semiconductor film. Thus, with use of a thin film transistor, a channel formation region of which is formed of the microcrystalline semiconductor film, for switching of a liquid crystal element, the area of the channel formation region, that is, the area of the thin film transistor can be decreased. Accordingly, the area occupied by the thin film transistor in a single pixel is decreased, and an aperture ratio of the pixel can be increased. As a result of this, a liquid crystal display device with high resolution can be manufactured.

The buffer layer **54** can be formed by a plasma CVD method using silicon hydride such as  $\text{SiH}_4$  or  $\text{Si}_2\text{H}_6$ . Alternatively, with a dilution of silicon hydride mentioned above with one or plural kinds of rare gas elements selected from helium, argon, krypton, and neon, an amorphous semiconductor film can be formed. With use of hydrogen at a flow rate which is 1 to 20 times, preferably, 1 to 10 times, more preferably, 1 to 5 times higher than that of silicon hydride, a hydrogen-containing amorphous semiconductor film can be formed. With the use of silicon hydride mentioned above and nitrogen or ammonia, a nitrogen-containing amorphous semiconductor film can be formed. With use of silicon

hydride mentioned above and a gas containing fluorine, chlorine, bromine, or iodine (F<sub>2</sub>, Cl<sub>2</sub>, Br<sub>2</sub>, I<sub>2</sub>, HF, HCl, HBr, HI, or the like), an amorphous semiconductor film containing fluorine, chlorine, bromine, or iodine can be formed. Note that, in place of silicon hydride, SiH<sub>2</sub>Cl<sub>2</sub>, SiHCl<sub>3</sub>, SiCl<sub>4</sub>, SiF<sub>4</sub>, or the like can be used.

Alternatively, as the buffer layer **54**, an amorphous semiconductor film can be formed by sputtering with hydrogen or a rare gas using an amorphous semiconductor as a target. In this case, by inclusion of ammonia, nitrogen, or N<sub>2</sub>O in an atmosphere, a nitrogen-containing amorphous semiconductor film can be formed. Alternatively, by inclusion of a gas including fluorine, chlorine, bromine, or iodine (F<sub>2</sub>, Cl<sub>2</sub>, Br<sub>2</sub>, I<sub>2</sub>, HF, HCl, HBr, HI, or the like) in an atmosphere, an amorphous semiconductor film containing fluorine, chlorine, bromine, or iodine can be formed.

Still alternatively, the buffer layer **54** may be formed by formation of an amorphous semiconductor film on the surface of the microcrystalline semiconductor film **53** by a plasma CVD method or a sputtering method and then by hydrogenation, nitridation, or halogenation of the surface of the amorphous semiconductor film through processing of the surface of the amorphous semiconductor film with hydrogen plasma, nitrogen plasma, or halogen plasma. Yet alternatively, the surface of the amorphous semiconductor film may be processed with helium plasma, neon plasma, argon plasma, krypton plasma, or the like.

The buffer layer **54** is preferably formed using an amorphous semiconductor film which does not contain crystal grains. Therefore, when the buffer layer **54** is formed by a high-frequency plasma CVD method or a microwave plasma CVD method with a frequency of several tens to several hundreds of megahertz, formation conditions are preferably controlled such that an amorphous semiconductor film does not contain crystal grains.

The buffer layer **54** is partly etched in a later formation process of a source region and a drain region in some cases, and in that case, the buffer layer **54** is preferably formed at such a thickness that a part of the buffer layer **54** is left after the etching. Typically, the thickness of the buffer layer is preferably from 150 nm to 400 nm, inclusive. In a liquid crystal display device in which application voltage to a thin film transistor is high (e.g., approximately 15 V), by setting the thickness of the buffer layer **54** within the above range, the withstand voltage is enhanced, and even when a high voltage is applied to a thin film transistor, the thin film transistor can be prevented from deteriorating.

Note that it is preferable that an impurity element imparting one conductivity type such as phosphorus or boron be not added to the buffer layer **54**. In particular, it is preferable that boron contained in the microcrystalline semiconductor film for threshold control or phosphorus contained in the semiconductor film to which an impurity element imparting one conductivity type is added be not mixed into the buffer layer **54**. As a result of this, by elimination of a region where leakage current is generated due to a PN junction, leakage current can be decreased. By formation of an amorphous semiconductor film, to which an impurity element imparting one conductivity type such as phosphorus or boron is not added, between the semiconductor film to which an impurity element imparting one conductivity type is added and the microcrystalline semiconductor film, the diffusion of the impurity contained in each of the microcrystalline semiconductor film and source and drain regions can be prevented.

By formation of an amorphous semiconductor film, moreover, an amorphous semiconductor film containing hydrogen, nitrogen, or halogen on the surface of the microcrystalline

semiconductor film **53**, surfaces of crystal grains contained in the microcrystalline semiconductor film **53** can be prevented from being oxidized naturally. In particular, in a region where an amorphous semiconductor is in contact with microcrystal grains, a crack is likely to be caused due to distortion of crystal lattice. When this crack is exposed to oxygen, the crystal grains are oxidized, whereby silicon oxide is formed. However, by formation of the buffer layer on the surface of the microcrystalline semiconductor film **53**, the microcrystal grains can be prevented from being oxidized. Furthermore, by formation of the buffer layer, the microcrystalline semiconductor film can be prevented from being mixed with an etching residue which is generated in forming source and drain regions later.

The buffer layer **54** is formed using an amorphous semiconductor film or an amorphous semiconductor film containing hydrogen, nitrogen, or halogen. An amorphous semiconductor film has a larger energy gap than the microcrystalline semiconductor film (the energy gap of the amorphous semiconductor film is 1.1 eV to 1.5 eV and the energy gap of the microcrystalline semiconductor film is 1.6 eV to 1.8 eV) and has a higher resistance, and has a lower mobility, i.e., a fifth to a tenth of that of the microcrystalline semiconductor film. Therefore, in a thin film transistor to be formed later, the buffer layer formed between source and drain regions and the microcrystalline semiconductor film functions as a high-resistant region and the microcrystalline semiconductor film functions as a channel formation region. Accordingly, the off current of the thin film transistor can be reduced. When the thin film transistor is used as a switching element of a liquid crystal display device, the contrast of the liquid crystal display device can be improved.

As for the semiconductor film **55** to which an impurity element imparting one conductivity type is added, in the case where an n-channel thin film transistor is to be formed, phosphorus may be added as a typical impurity element, and an impurity gas such as PH<sub>3</sub> may be added to silicon hydride. In the case where a p-channel thin film transistor is to be formed, boron may be added as a typical impurity element, and an impurity gas such as B<sub>2</sub>H<sub>6</sub> may be added to silicon hydride. The semiconductor film **55** to which an impurity element imparting one conductivity type is added can be formed of a microcrystalline semiconductor or an amorphous semiconductor. Further, the semiconductor film **55** to which an impurity element imparting one conductivity type is added may be a multilayer in which an amorphous semiconductor film to which an impurity element imparting one conductivity type is added and a microcrystalline semiconductor film to which an impurity element imparting one conductivity type is added are stacked. An amorphous semiconductor film to which an impurity element imparting one conductivity type is added is formed on the buffer layer **54** side and a microcrystalline semiconductor film to which an impurity element imparting one conductivity type is added are stacked thereover, so that resistance varies gradually, and thus carriers easily move and the mobility can be enhanced. The semiconductor film **55** to which an impurity element imparting one conductivity type is added is formed to a thickness of from 2 nm to 50 nm, inclusive. By formation of the semiconductor film to which an impurity element imparting one conductivity type is added to a small thickness, throughput can be improved.

Here, a plasma CVD apparatus, with which from the gate insulating films **52a** and **52b** to the semiconductor film **55** to which an impurity element imparting one conductivity type is added can be formed successively, is described with reference to FIG. 10. FIG. 10 is a schematic diagram showing an upper cross-sectional view of a plasma CVD apparatus, which has a

structure where a loading chamber 1110, an unloading chamber 1115, and reaction chambers (1) 1111 to (4) 1114 are provided around a common chamber 1120. Between the common chamber 1120 and the other chambers, gate valves 1122 to 1127 are provided so that processes performed in the chambers do not interface with each other. Substrates are loaded into a cassette 1128 in the loading chamber 1110 and a cassette 1129 in the unloading chamber 1115 and carried to the reaction chambers (1) 1111 to (4) 1114 with a transport means 1121 of the common chamber 1120. In this apparatus, a reaction chamber can be allocated for each of different kinds of deposition films, and a plurality of different films can be formed successively without any exposure to the atmosphere.

In each of the reaction chambers (1) to (4), the gate insulating films 52a and 52b, the microcrystalline semiconductor film 53, the buffer layer 54, and the semiconductor film 55 to which an impurity element imparting one conductivity type is added are stacked. In this case, a plurality of films of different kinds can be stacked successively by change of source gases. In this case, after the gate insulating films are formed, silicon hydride such as silane is introduced into the reaction chamber, residual oxygen and silicon hydride are reacted with each other, and the reactant is exhausted from the reaction chamber, whereby the concentration of residual oxygen in the reaction chamber can be decreased. Accordingly, the concentration of oxygen to be contained in the microcrystalline semiconductor film can be decreased. In addition, crystal grains contained in the microcrystalline semiconductor film can be prevented from being oxidized.

Alternatively, the gate insulating films 52a and 52b, the microcrystalline semiconductor film 53, and the buffer layer 54 are formed in each of the reaction chambers (1) and (3), and the semiconductor film 55 to which an impurity element imparting one conductivity type is added is formed in each of the reaction chambers (2) and (4). By formation of a film with an impurity element imparting one conductivity type alone, the impurity imparting one conductivity type which remains in the chamber can be prevented from being mixed into another film.

In this manner, with a microwave plasma CVD apparatus where a plurality of chambers is connected, the gate insulating films 52a and 52b, the microcrystalline semiconductor film 53, the buffer layer 54, and the semiconductor film 55 to which an impurity element imparting one conductivity type is added can be formed at the same time. Thus, mass productivity can be improved. In addition, even when maintenance or cleaning is performed in one of reaction chambers, film formation processes can be performed in the other reaction chambers, whereby cycle time for film formation can be shortened. Furthermore, each interface between stacked layers can be formed without being contaminated by an atmospheric constituent or a contaminant impurity element floating in the atmosphere. Thus, variations in characteristics of thin film transistors can be reduced.

Alternatively, it is possible that the gate insulating films 52a and 52b are formed in the reaction chamber (1), the microcrystalline semiconductor film 53 and the buffer layer 54 are formed in the reaction chamber (2), and the semiconductor film 55 to which an impurity element imparting one conductivity type is added is formed in the reaction chamber (3). Still alternatively, in the case where the gate insulating film 52a is to be formed of a silicon oxide film or a silicon oxynitride film and the gate insulating film 52b is to be formed of a silicon nitride film or a silicon nitride oxide film, five reaction chambers may be provided. A silicon oxide film or a silicon oxynitride film may be formed as the gate insulating film 52a in a reaction chamber (1); a silicon nitride film

or a silicon nitride oxide film may be formed as the gate insulating film 52b in a reaction chamber (2); a microcrystalline semiconductor film may be formed in a reaction chamber (3); a buffer layer may be formed in a reaction chamber (4); and a semiconductor film to which an impurity element imparting one conductivity type is added may be formed in a reaction chamber (5). The deposition rate of a microcrystalline semiconductor film is low; thus, microcrystalline semiconductor films may be formed in a plurality of reaction chambers. For example, the gate insulating films 52a and 52b may be formed in a reaction chamber (1); the microcrystalline semiconductor films 53 may be formed in reaction chambers (2) and (3); the buffer layer 54 may be formed in a reaction chamber (4); and the semiconductor film 55 to which an impurity element imparting one conductivity type is added may be formed in a reaction chamber (5). In this manner, by formation of the microcrystalline semiconductor films 53 in a plurality of reaction chambers at the same time, throughput can be improved. In this case, it is preferable that the inner wall of each reaction chamber be coated with a film of the same kind as a film to be formed therein.

With use of a microwave plasma CVD apparatus having such a structure as described above, films of similar kinds or a film of one kind can be formed in each reaction chamber and can be formed successively without any exposure to the atmosphere. Therefore, each interface between stacked layers can be formed without being contaminated by a residue of the previously formed film or an impurity element floating in the atmosphere.

Note that the microwave plasma CVD apparatus shown in FIG. 10 is provided with the loading chamber and the unloading chamber separately, which may be a single loading/unloading chamber. In addition, the plasma CVD apparatus may be provided with a spare chamber. By preheating of a substrate in the spare chamber, heating time needed before film formation in each reaction chamber can be shortened; thus, throughput can be improved.

Film formation processes are described below. In each film formation process, a gas to be supplied from a gas supply portion may be selected depending on the purpose.

Here, a method is given as an example, in which a silicon oxynitride film is formed as the gate insulating film 52a and a silicon nitride oxide film is formed as the gate insulating film 52b.

First, inside of a processing container in a reaction chamber of the microwave plasma CVD apparatus is cleaned with fluorine radicals. Note that the inside of the reaction chamber can be cleaned by introduction of fluorine radicals into the reaction chamber, which are generated by introduction of carbon fluoride, nitrogen fluoride, or fluorine into a plasma generator provided outside of the reaction chamber and by dissociation thereof.

After cleaning with fluorine radicals, a large amount of hydrogen is introduced into the reaction chamber, whereby residual fluorine inside the reaction chamber can be reacted with hydrogen, so that the concentration of residual fluorine can be decreased. Accordingly, the amount of fluorine to be mixed into a protective film that is to be deposited later on the inner wall of the reaction chamber can be decreased, and the thickness of the protective film can be decreased.

Next, on the surface of the inner wall of the processing container in the reaction chamber, or the like, an oxynitride film is deposited as the protection film. Here, the pressure in the processing container is set to be 1 Pa to 200 Pa, preferably, 1 Pa to 100 Pa, and one or more kinds of rare gases such as helium, argon, xenon, and krypton is introduced as a plasma ignition gas. Furthermore, hydrogen and any one kind of rare

gases are introduced. In particular, it is preferable that helium, moreover, helium and hydrogen be used as a plasma ignition gas.

Although helium has a high ionization energy of 24.5 eV, it has a metastable state at about 20 eV. Therefore, helium can be ionized at about 4 eV during discharge. Thus, discharge starting voltage is low and discharge can be maintained easily. Accordingly, uniform plasma can be maintained, and power saving can be achieved.

Alternatively, as the plasma ignition gas, an oxygen gas and one or more kinds of rare gases such as helium, argon, xenon, and krypton may be introduced. By introduction of an oxygen gas together with a rare gas into the processing container, plasma ignition can be facilitated.

Next, a power supply apparatus is turned on and the output of the power supply apparatus is set to be 500 W to 6000 W, preferably, 4000 W to 6000 W to generate plasma. Then, a source gas is introduced into the processing container through a gas pipe. Specifically, by introduction of dinitrogen monoxide, a rare gas, and silane as a source gas, a silicon oxynitride film is formed as the protective film on the inner wall of the processing container. The flow rate of silicon hydride at this time is set to be 50 sccm to 300 sccm and that of dinitrogen monoxide is set to be 500 sccm to 6000 sccm, and the thickness of the protective film is set to be 500 nm to 2000 nm.

Then, the supply of the source gas is stopped, the pressure in the processing container is decreased, and the power supply apparatus is turned off. After that, a substrate is introduced onto the supporting base in the processing container.

Next, through a similar process to that of the protective film, a silicon oxynitride film is deposited over the substrate as the gate insulating film **52a**.

After the silicon oxynitride film is deposited to a predetermined thickness, the supply of the source gas is stopped, the pressure in the processing container is decreased, and the power supply apparatus is turned off.

Next, the pressure in the processing container is set to be 1 Pa to 200 Pa, preferably, 1 Pa to 100 Pa, and one or more kinds of rare gases such as helium, argon, xenon, and krypton which is a plasma ignition gas and silane, dinitrogen monoxide, and ammonia which are a source gas are introduced. Note that, as the source gas, nitrogen may be introduced instead of ammonia. Then, the power supply apparatus is turned on, and the output of the power supply apparatus is set to be 500 W to 6000 W, preferably, 4000 W to 6000 W to generate plasma. Next, the source gas is introduced into the processing container through the gas pipe, and a silicon nitride oxide film is formed as the gate insulating film over the silicon oxynitride film over the substrate **1130**. Then, the supply of the source gas is stopped, the pressure in the processing container is decreased, the power supply apparatus is turned off, and the film formation process is completed.

Through the above-described process, the silicon oxynitride film is formed as the protective film on the inner wall of the reaction chamber, and the silicon oxynitride film and the silicon nitride oxide film are successively formed over the substrate, whereby mixture of an impurity such as silicon oxide into the silicon nitride oxide film on the upper layer side can be suppressed. By formation of the above-mentioned films by a microwave plasma CVD method using a power supply apparatus which can generate a microwave as a power supply apparatus, plasma density can be made to be high and the films can be formed to have high withstand voltage. With use of the films as a gate insulating film, variations in threshold voltages of transistors can be suppressed. In addition, BT characteristics can be improved. Moreover, resistance to static electricity is increased, and a transistor which is not

easily destroyed even when high voltage is applied can be manufactured. Furthermore, a transistor which is less destroyed over time can be manufactured. In addition, a transistor with less hot carrier damage can be manufactured.

In the case where a gate insulating film is a single layer of a silicon oxynitride film which is formed using the microwave plasma CVD apparatus, the above-described formation method of the protective film and the formation method of the silicon oxynitride film are used. In particular, when the flow rate ratio of dinitrogen monoxide to silane is set to be 50:1 to 300:1, preferably, 50:1 to 250:1, the silicon oxynitride film can be formed to have high withstand voltage.

Next, a film formation process is described, in which a microcrystalline semiconductor film and an amorphous semiconductor film as a buffer layer are successively formed by a plasma CVD method. First, in a similar manner to the gate insulating films, the inside of the reaction chamber is cleaned. Next, a silicon film is deposited as a protective film inside the processing container. Here, the pressure in the processing container is set to be 1 Pa to 200 Pa, preferably, 1 Pa to 100 Pa, and one or more kinds of rare gases such as helium, argon, xenon, and krypton is introduced as a plasma ignition gas. Note that hydrogen may be introduced together with the rare gas.

Then, the power supply apparatus is turned on, and the output of the power supply apparatus is set to be 500 W to 6000 W, preferably, 4000 W to 6000 W to generate plasma. Next, a source gas is introduced into the processing container through the gas pipe. Specifically, by introduction of a silicon hydride gas and a hydrogen gas as a source gas, a microcrystalline silicon film is formed as a protective film on the inner wall of the processing container. Alternatively, a microcrystalline semiconductor film can be formed from a dilution of a silicon hydride gas and a hydrogen gas with one or more kinds of rare gas elements selected from helium, argon, krypton, and neon. The flow rate ratio of hydrogen to silicon hydride at this time is set to be 5:1 to 1000:1, preferably, 50:1 to 200:1, more preferably, 100:1 to 150:1. In addition, the thickness of the protective film at this time is set to be 500 nm to 2000 nm. Note that, before the power supply apparatus is turned on, a silicon hydride gas and a hydrogen gas in addition to the above-mentioned rare gas may be introduced into the processing container.

Alternatively, an amorphous semiconductor film can be formed as the protective film from a dilution of a silicon hydride gas and a hydrogen gas with one or more kinds of rare gas elements selected from helium, argon, krypton, and neon.

Then, the supply of the source gas is stopped, the pressure in the processing container is decreased, and the power supply apparatus is turned off. After that, the substrate is introduced onto the support base in the processing container.

Next, the surface of the gate insulating film **52b** formed over the substrate may be processed with hydrogen plasma. By processing with hydrogen plasma before the microcrystalline semiconductor film is formed, lattice distortion at the interface between the gate insulating film and the microcrystalline semiconductor film can be decreased, and interface characteristics of the gate insulating film and the microcrystalline semiconductor film can be improved. Accordingly, electric characteristics of a thin film transistor to be formed later can be improved.

In the hydrogen plasma processing, the amorphous semiconductor film or the microcrystalline semiconductor film which is formed as the protective film inside the processing container is also processed with hydrogen plasma, whereby the protective film is etched and a slight amount of semiconductor is deposited on the surface of the gate insulating film

**52b.** The semiconductor serves as a nucleus of crystal growth, and with the nucleus, a microcrystalline semiconductor film is deposited. As a result, lattice distortion at the interface between the gate insulating film and the microcrystalline semiconductor film can be decreased, and interface characteristics of the gate insulating film and the microcrystalline semiconductor film can be improved. Accordingly, electric characteristics of a thin film transistor to be formed later can be improved.

Next, in a similar process to the protective film, a microcrystalline silicon film is deposited over the substrate. The thickness of the microcrystalline silicon film is set to be greater than 0 nm and less than or equal to 50 nm, preferably, greater than 0 nm and less than or equal to 20 nm.

After the microcrystalline silicon film is deposited to a predetermined thickness, the supply of the source gas is stopped, the pressure in the processing container is decreased, the power supply apparatus is turned off, and the film formation process for the microcrystalline semiconductor film is completed.

Next, the pressure in the processing container is decreased, and the flow rate of the source gas is adjusted. Specifically, the flow rate of a hydrogen gas is significantly decreased compared to that under film formation conditions for the microcrystalline semiconductor film. Typically, a hydrogen gas is introduced at a flow rate which is 1 to 20 times, preferably, 1 to 10 times, more preferably, 1 to 5 times higher than the flow rate of silicon hydride. Alternatively, a silicon hydride gas is introduced without any hydrogen gas being introduced into the processing container. By such a decrease in flow rate of hydrogen to silicon hydride, the deposition rate of an amorphous semiconductor film as the buffer layer can be increased. Alternatively, a silicon hydride gas is diluted with one or more kinds of rare gas elements selected from helium, argon, krypton, and neon. Next, the power supply apparatus is turned on and the output of the power supply apparatus is set to be 500 W to 6000 W, preferably, 4000 W to 6000 W to generate plasma **200**, whereby an amorphous semiconductor film can be formed. Because the deposition rate of an amorphous semiconductor film is higher than that of a microcrystalline semiconductor film, the pressure in the processing container can be set to be low. The thickness of the amorphous semiconductor film at this time is set to be 200 nm to 400 nm.

After the amorphous semiconductor film is deposited to a predetermined thickness, the supply of the source gas is stopped, the pressure in the processing container is decreased, the power supply apparatus is turned off, and the film formation process for the amorphous semiconductor film is completed.

Note that the microcrystalline semiconductor film **53** and the amorphous semiconductor film which is the buffer layer **54** may be formed while plasma is ignited. Specifically, while the flow rate ratio of hydrogen to silicon hydride which are the source gas used to form the microcrystalline semiconductor film **53** is gradually decreased, the microcrystalline semiconductor film **53** and the amorphous semiconductor film which is the buffer layer **54** are stacked. By such a method, an impurity is not deposited at the interface between the microcrystalline semiconductor film **53** and the buffer layer **54**; interface with less distortion can be formed; and electric characteristics of a thin film transistor to be formed later can be improved.

In the case where the microcrystalline semiconductor film **53** is formed, a microwave plasma CVD apparatus with a frequency of 1 GHz or more is preferably used. Microwave plasma has high electron density, and a large number of radicals are formed from a source gas and supplied to the

substrate **1130**. Thus, reaction of radicals at the surface of the substrate is promoted, and the deposition rate of microcrystalline silicon can be increased. By a plasma CVD method with a high frequency of 1 MHz to 20 MHz, typically 13.56 MHz, or a high frequency in VHF band, from 20 MHz to about 120 MHz, typically, 27.12 MHz or 60 MHz, the microcrystalline semiconductor film can be formed.

Note that, in each of the manufacturing processes of the gate insulating film and the semiconductor film, in the case where a protective film of 500 nm to 2000 nm is formed on the inner wall of the reaction chamber, the cleaning process and the formation process of the protective film can be omitted.

The conductive films **65a** to **65c** are formed over the semiconductor film **55** to which an impurity element imparting one conductivity type is added, using a single layer or a stacked layer of aluminum, copper or an aluminum alloy to which an element to improve heat resistance or an element to prevent a hillock, e. g., silicon, titanium, neodymium, scandium, or molybdenum, is added. Alternatively, the conductive film may have a stacked-layer structure where a film on the side in contact with the semiconductor film to which an impurity element imparting one conductivity type is added is formed of titanium, tantalum, molybdenum, tungsten, or nitride of any of these elements and an aluminum film or an aluminum alloy film is formed thereover. Still alternatively, the conductive film may have a stacked-layer structure where an aluminum film or an aluminum alloy film is sandwiched between upper and lower films of titanium, tantalum, molybdenum, tungsten, or nitride of any of these elements. Here, as the conductive film, a conductive film with a three-layer structure where conductive films **65a** to **65c** are stacked is described. A stacked-layer conductive film where molybdenum films are used as the conductive films **65a** and **65c** and an aluminum film is used as the conductive film **65b** or a stacked-layer conductive film where titanium films are used as the conductive films **65a** and **65c** and an aluminum film is used as the conductive film **65b** can be given. The conductive films **65a** to **65c** are formed by a sputtering method or a vacuum evaporation method.

A resist **80** can be a positive type resist or a negative type resist. In this case, a positive type resist is used.

Next, the resist **80** is irradiated with light using a multi-tone photomask **59** as a second photomask to expose the resist **80** to light.

Now light exposure using the multi-tone photomask **59** is described with reference to FIGS. **11A** to **11D**.

A multi-tone photomask can achieve three levels of light exposure, an exposed portion, a half-exposed portion, and an unexposed portion; one-time exposure and development process allows a resist mask with regions of plural thicknesses (typically, two kinds of thicknesses) to be formed. The use of a multi-tone photomask allows the number of photomasks to be reduced.

Typical examples of a multi-tone photomask include a gray-tone mask **59a** as illustrated in FIG. **11A**, and a half-tone mask **59b** as illustrated in FIG. **11C**.

As illustrated in FIG. **11A**, the gray-tone mask **59a** includes a substrate **163** having a light-transmitting property, and a light-blocking portion **164** and a diffraction grating **165** that are formed thereon. The light transmittance of the light-blocking portion **164** is 0%. The diffraction grating **165** has a light-transmitting portion in a slit form, a dot form, a mesh form, or the like with intervals which are less than or equal to the resolution limit for light used for the exposure; thus, the light transmittance can be controlled. The diffraction grating **165** can have regularly-arranged slits, dots, or meshes form, or irregularly-arranged slits, dots, or meshes.

For the substrate **163** having a light-transmitting property, a substrate having a light-transmitting property, such as a quartz substrate, can be used. The light-blocking portion **164** and the diffraction grating **165** can be formed using a light-blocking material such as chromium or chromium oxide, which absorbs light.

When the gray-tone mask **59a** is irradiated with light for exposure, the light transmittance **166** of the light-blocking portion **164** is 0% and that of a region where neither the light-blocking portion **164** nor the diffraction grating **165** are provided is 100%, as illustrated in FIG. **11B**. The light transmittance of the diffraction grating **165** can be controlled in a range of 10% to 70%. The light transmittance of the diffraction grating **165** can be controlled by adjusting an interval or a pitch between slits, dots, or meshes of the diffraction grating **165**.

As illustrated in FIG. **11C**, the half-tone mask **59b** includes the substrate **163** having a light-transmitting property, and a semi-transmissive portion **167** and a light-blocking portion **168** that are formed thereon. The semi-transmissive portion **167** can be formed using MoSiN, MoSi, MoSiO, MoSiON, CrSi, or the like. The light-blocking portion **168** can be formed using a light-blocking material such as chromium or chromium oxide, which absorbs light.

When the half-tone mask **59b** is irradiated with light for exposure, the light transmittance **169** of the light-blocking portion **168** is 0% and that of a region where neither the light-blocking portion **168** nor the semi-transmissive portion **167** is provided is 100%, as illustrated in FIG. **11D**. The light transmittance of the semi-transmissive portion **167** can be controlled in a range of 10% to 70%. The light transmittance of the semi-transmissive portion **167** can be controlled depending on a material of the semi-transmissive portion **167**.

After the light exposure using the multi-tone photomask is done, development is carried out, whereby the resist mask **81** having regions with different thicknesses can be formed, as illustrated in FIG. **1B**.

Next, with the resist mask **81**, the microcrystalline semiconductor film **53**, the buffer layer **54**, the semiconductor film **55** to which an impurity element imparting one conductivity type is added, and the conductive films **65a** to **65c** are etched for separation. As a result, a microcrystalline semiconductor film **61**, a buffer layer **62**, a semiconductor film **63** to which an impurity element imparting one conductivity type is added, and conductive films **85a** to **85c** can be formed, as illustrated in FIG. **2A**. Note that FIG. **2A** corresponds to a cross-sectional view taken along the line A-B in FIG. **5A** (excluding a resist mask **86**).

The side faces in the end portions of the microcrystalline semiconductor film **61** and the buffer layer **62** are inclined, so that leakage current can be prevented from flowing between the source and drain regions formed over the buffer layer **62** and the microcrystalline semiconductor film **61**. In addition, leakage current between the source and drain electrodes and the microcrystalline semiconductor film **61** can also be prevented. The inclination angle of the side faces in the end portions of the microcrystalline semiconductor film **61** and the buffer layer **62** is from 30° to 90°, preferably from 45° to 80°. By adopting such an angle, disconnection of the source electrode or the drain electrode due to the step can be prevented.

Next, ashing is conducted on the resist mask **81**. As a result, the area and the thickness of the resist are reduced. At this time, the resist in a region with a small thickness (a region overlapping with part of the gate electrode **51**) is removed to form separated resist masks **86**, as illustrated in FIG. **6B**.

Next, using the resist mask **86**, the semiconductor film **63** to which an impurity element imparting one conductivity type is added and the conductive films **85a** to **85c** are etched for separation. At this time, dry etching is conducted to separate the conductive films **85a** to **85c**. As a result, a pair of conductive films **89a** to **89c** and a pair of source and drain regions **89** can be formed, as illustrated in FIG. **2B**. In this etching process, a part of the buffer layer **62** is also etched. The buffer layer which is partly etched is referred to as a buffer layer **88**. The source and drain regions and the concave portion of the buffer layer can be formed in the same process. The buffer layer **88** has end portions protruding outside conductive films **85a** to **85c** because the buffer layer **88** is partly etched using the resist mask **86** with a reduced area.

Next, as illustrated in FIG. **2C**, the conductive films **89a** to **89c** are partly etched to form source and drain electrodes **92a** to **92c**. Here, by wet etching of the conductive films **89a** to **89c** with use of the resist mask **86**, the end portions of the conductive films **89a** to **89c** are selectively etched. As a result, the source and drain electrodes **92a** to **92c** having smaller areas than the resist mask **86** and the conductive films **89a** to **89c** can be formed. The end portions of the source and drain electrodes **92a** to **92c** are not aligned with the end portions of the source and drain regions **89**, and the end portions of the source and drain regions **89** are formed outside the end portions of the source and drain electrodes **92a** to **92c**. After that, the resist mask **86** is removed.

Note that FIG. **2C** corresponds to a cross-sectional view taken along the line A-B of FIG. **5B**. As illustrated in FIG. **5B**, it can be seen that the end portions of the source and drain regions **89** are located outside of the end portions of the source and drain electrodes **92c**. In addition, the end portions of the buffer layer **88** are located outside the end portions of the source and drain electrodes **92c** and the source and drain regions **89**. Further, one of the source and drain electrodes has a shape in which the one electrode partially surrounds the other of the source and drain regions (specifically, a U shape or a C shape). Thus, an area in which carriers can move can be increased, and thus the amount of current can be increased and an area for a thin film transistor can be reduced. In the inner portion of the gate electrode, the microcrystalline semiconductor film **87** and the source and drain electrodes **92c** are overlapped, and thus influence by unevenness at the end portions of the gate electrode is small and reduction of coverage and generation of leakage current can be suppressed. Note that one of the source and drain electrodes also functions as a source or drain wiring.

With such a shape as illustrated in FIG. **2C** in which the end portions of the source and drain electrodes **92a** to **92c** are not aligned with the end portions of the source and drain regions **89**, the end portions of the source and drain electrodes **92a** to **92c** are apart from each other; therefore, leakage current and short circuit between the source and drain electrodes can be prevented. Accordingly, a thin film transistor with high reliability and high withstand voltage can be manufactured.

Through the above-described process, a channel-etch thin film transistor **83** can be formed. In addition, the thin film transistor can be formed using two photomasks.

In the thin film transistor described in this embodiment mode, the gate insulating film, the microcrystalline semiconductor film, the buffer layer, the source and drain regions, and the source and drain electrodes are stacked over the gate electrode, and the buffer layer covers the surface of the microcrystalline semiconductor film which functions as a channel formation region. In addition, a concave portion (a groove) is formed in a part of the buffer layer, and regions other than the concave portion are covered with the source and drain

regions. That is, due to the concave formed in the buffer layer, the length of a path for carriers the source and drain regions is long; thus, leakage current between the source and drain regions can be reduced. In addition, because the concave is formed by etching of a part of the buffer layer, an etching residue which is generated in the formation step of the source and drain regions can be removed. Accordingly, leakage current (parasitic channel) can be prevented from being generated between the source and drain regions through the residue.

The buffer layer is formed between the microcrystalline semiconductor film which functions as a channel formation region and the source and drain regions. In addition, the buffer layer covers the surface of the microcrystalline semiconductor film. Because the buffer layer, which is formed to have high resistance, is extended to regions between the microcrystalline semiconductor film and the source and drain regions, leakage current generated in the case where the thin film transistor is turned off (i.e., the case where a negative voltage is applied to the gate electrode) can be reduced, and deterioration due to application of high voltage can be suppressed. Moreover, because the amorphous semiconductor film, the surface of which is subjected to termination by hydrogen, is formed as the buffer layer on the surface of the microcrystalline semiconductor film, the microcrystalline semiconductor film can be prevented from being oxidized, and an etching residue which is generated in the formation step of the source and drain regions can be prevented from being mixed into the microcrystalline semiconductor film. Accordingly, the thin film transistor has high electric characteristics and excellent drain withstand voltage.

Because the end portions of the source and drain electrodes are apart from each other due to the shape where the end portions of the source and drain electrodes are not aligned with the end portions of the source and drain regions, leakage current and short circuit between the source and drain electrodes can be prevented.

Next, as illustrated in FIG. 3A, an insulating film 76 is formed over the source and drain electrodes 92a to 92c, the source and drain regions 89, the buffer layer 88, the microcrystalline semiconductor film 87, and the gate insulating film 52b. The insulating film 76 can be formed in a similar manner to the gate insulating films 52a and 52b. Note that the insulating film 76 is provided to prevent entry of a contaminant impurity such as an organic substance, a metal substance, or moisture floating in the atmosphere and is preferably a dense film. By use of a silicon nitride film as the insulating film 76, the oxygen concentration in the buffer layer 88 can be made to be  $5 \times 10^{19}$  atoms/cm<sup>3</sup> or less, preferably,  $1 \times 10^{19}$  atoms/cm<sup>3</sup> or less.

Next, a contact hole is formed in the insulating film 76, and a pixel electrode 77 is formed in the contact hole to be in contact with the source or drain electrode 92c. Note that FIG. 3B corresponds to a cross-sectional view taken along a line A-B of FIG. 5C.

The pixel electrode 77 can be formed using a light-transmitting conductive material such as indium oxide containing tungsten oxide, indium zinc oxide containing tungsten oxide, indium oxide containing titanium oxide, indium tin oxide containing titanium oxide, indium tin oxide (hereinafter referred to as ITO), indium zinc oxide, or indium tin oxide to which silicon oxide is added.

Alternatively, the pixel electrode 77 can be formed using a conductive composition containing a conductive high-molecular compound (also referred to as a conductive polymer). It is preferable that the pixel electrode formed using the conductive composition have a sheet resistance of 10000

$\Omega$ /square or less and a light transmittance of 70% or more at a wavelength of 550 nm. In addition, it is preferable that the resistivity of the conductive high-molecular compound contained in the conductive composition be 0.1  $\Omega$ -cm or less.

As the conductive high-molecular compound, a so-called  $\pi$  electron conjugated conductive high-molecular compound can be used. Examples include polyaniline and its derivatives, polypyrrole and its derivatives, polythiophene and its derivatives, copolymers of two or more kinds of them, and the like.

Through the above process, an element substrate which can be used for a liquid crystal display device can be formed.

As illustrated in FIG. 2A, the microcrystalline semiconductor film 61, the buffer layer 62, the semiconductor film 63 to which an impurity element imparting one conductivity type is added, and the conductive films 85a to 85c are formed, and then as illustrated in FIG. 4A, the conductive films 85a to 85c are etched using the resist mask 86. In this case, the conductive films 85a to 85c are etched isotropically using the resist mask 86, so that the exposed portions and vicinity portions thereof of the conductive film 85a to 85c are selectively etched. As a result, the source and drain electrodes 92a to 92c having smaller regions than the resist mask 86 can be formed.

Next, as illustrated in FIG. 4B, the semiconductor film 63 to which an impurity element imparting one conductivity type is added is etched using the resist mask 86. In this case, the semiconductor film 63 to which an impurity element imparting one conductivity type is added is anisotropically etched by dry etching, so that the source and drain regions 89 having almost the same area as the resist mask 86 can be formed.

With such a shape in which the end portions of the source and drain electrodes 92a to 92c and the end portions of the source and drain regions 89 are not aligned, the end portions of the source and drain electrodes 92a to 92c are apart from each other; therefore, leakage current and short circuit between the source and drain electrodes can be prevented. Accordingly, a thin film transistor with high reliability and high withstand voltage can be manufactured.

As illustrated in FIGS. 1A and 1B, FIGS. 2A to 2C, FIGS. 3A and 3B, and FIGS. 4A and 4B, the conductive film is etched by wet etching, and the semiconductor film to which an impurity element imparting one conductivity type is added is etched by dry etching, so that a structure in which the end portions of the source and drain electrodes and the end portions of the source and drain regions are not aligned and are different be obtained with a small number of photomasks.

Next, a method for manufacturing a thin film transistor, which is different from that in the above mode, is described with reference to FIGS. 6A to 6C, FIGS. 7A to 7C, FIGS. 8A and 8B, and FIGS. 9A to 9D. Here, a structure is described, in which a source or drain electrode is separated from a source or drain wiring.

As illustrated in FIG. 6A, a gate electrode 51 is formed over a substrate 50. Next, over the gate electrode 51, gate insulating films 52a and 52b, a microcrystalline semiconductor film 53, a buffer layer 54, a semiconductor film 55 to which an impurity element imparting one conductivity type is added, and a conductive film 65a are sequentially formed. Then, over the conductive film 65a, resist is applied, and a resist mask 81 having regions with different thicknesses is formed using a multi-tone mask illustrated in FIG. 1A.

Next, the microcrystalline semiconductor film 53, the buffer layer 54, the semiconductor film 55 to which an impurity element imparting one conductivity type is added, and the conductive film 65a is etched using the resist mask 81 for separation. As a result, as illustrated in FIG. 6B, a microcrystalline semiconductor film 61, a buffer layer 62, a semiconductor film 63 to which an impurity element imparting one

conductivity type is added, and a conductive film **85a** can be formed. Note that FIG. 6B corresponds to a cross-sectional view taken along the line A-B of FIG. 9A (excluding the resist mask **86**).

Next, ashing is conducted on the resist mask **81** to form separated resist masks **86**. Then, the semiconductor film **63** to which an impurity element imparting one conductivity type is added and the conductive film **85a** are etched the resist mask **86** for separation. As a result, as illustrated in FIG. 6C, a pair of conductive films **89a** and a pair of source and drain regions **89** can be formed. Note that, in this etching step, a part of the buffer layer **62** is also etched. The partly etched buffer layer is referred to as a buffer layer **88**. Here, because a part of the buffer layer **88** is etched using the resist mask **86** with a reduced area, the buffer layer **88** has a shape where it extends outside the conductive film **85a**. As shown in this embodiment mode, the side face of the buffer layer is stepwise, and thus the coverage with an insulating film to be formed later is increased. Therefore, leakage current between a pixel electrode formed over the insulating film and a thin film transistor can be reduced.

Next, ashing is conducted on the resist mask **86**. As a result, as illustrated in FIG. 7A, the area of the resist mask is reduced, and the thickness thereof is reduced. By using the ashed resist mask **91**, the conductive film **89a** is partly etched, and as illustrated in FIG. 7B, the source and drain electrodes **92a** are formed. The end portions of the source and drain electrodes **92a** are not aligned with the end portions of the source and drain regions **89**. In this case, an exposed portion of the conductive film **89a** is anisotropically etched using the resist mask **91**. After that, the resist mask **91** is removed.

As a result, the source and drain electrodes **92a** having a smaller area than the conductive film **89a** are formed. Then, the resist mask **91** is removed. FIG. 7B corresponds to a cross-sectional view taken along the line A-B of FIG. 9B. As illustrated in FIG. 9B, it can be seen that the end portions of the source and drain regions **89** are located outside the end portions of the source and drain electrodes **92a**. In addition, the end portions of the buffer layer **88** are located outside the source and drain electrodes **92a** and the source and drain regions **89**. The source and drain electrodes **92a** are isolated from each other and not connected to an electrode formed in an adjacent pixel. In this case, by using the resist mask **91** formed by ashing of the resist mask **86**, the source and drain electrodes **92a** are formed. Alternatively, as illustrated in FIGS. 1A and 1B, FIGS. 2A to 2C, FIGS. 3A and 3B, and FIGS. 4A and 4B, wet etching using the resist mask **86** may be conducted to form the source and drain electrodes **92a** to **92c**.

As illustrated in FIG. 7B, with a shape in which the end portions of the source and drain electrode **92a** and the end portions of the source and drain region **89** are not aligned, the end portions of the source and drain electrodes **92a** are apart from each other; therefore, leakage current and short circuit between the source and drain electrodes can be prevented. Accordingly, a thin film transistor with high reliability and high withstand voltage can be manufactured.

Next, as illustrated in FIG. 7C, an insulating film **76** is formed over the source and drain electrodes **92a**, the source and drain regions **89**, the buffer layer **88**, and the gate insulating film **52b**. The insulating film **76** can be formed in a similar manner to the gate insulating films **52a** and **52b**.

Next, as illustrated in FIG. 8A, a contact hole is formed in the insulating film **76**; stacked wirings **93b** and **93c** are formed in the contact hole to be in contact with one of the source and drain electrodes **92a**. Note that FIG. 8A corresponds to a cross-sectional view taken along the line A-B of

FIG. 9C. The wirings **93b** and **93c** are wirings to be connected to a source or drain electrode formed in an adjacent pixel.

Next, a contact hole is formed in the insulating film **76**, and a pixel electrode **77** is formed in the contact hole to be in contact with the other of the source and drain electrodes **92a**, as illustrated in FIG. 8B. Note that FIG. 8B corresponds to a cross-sectional view taken along a line A-B of FIG. 9D.

Through the above-described process, a channel-etch thin film transistor **84** can be formed. This channel-etch thin film transistor requires a smaller number of manufacturing steps and can achieve cost reduction. By formation of a channel formation region with a microcrystalline semiconductor film, a field-effect mobility of  $1 \text{ cm}^2/\text{V}\cdot\text{sec}$  to  $20 \text{ cm}^2/\text{V}\cdot\text{sec}$  can be achieved. Accordingly, this thin film transistor can be used as a switching element of a pixel in a pixel portion and as an element included in a scan line (gate line) side driver circuit.

In accordance with this embodiment mode, a highly reliable thin film transistor with excellent electric characteristics can be manufactured.

#### Embodiment Mode 2

In this embodiment mode, a liquid crystal display device including a thin film transistor shown in Embodiment Mode 1 is described below.

First, a vertical alignment (VA) liquid crystal display device is described. The VA liquid crystal display device is a kind of mode in which alignment of liquid crystal molecules of a liquid crystal panel is controlled. The VA liquid crystal display device is a mode in which liquid crystal molecules are vertical to a panel surface when voltage is not applied. In particular, in this embodiment mode, it is devised that a pixel is divided into several regions (sub-pixels) so that molecules are aligned in different directions in the respective regions. This is referred to as domain multiplication or multi-domain design. In the following description, a liquid crystal display device with multi-domain design is described.

FIGS. 16 and 17 show a pixel electrode and a counter electrode, respectively. FIG. 16 is a plan view of a side of a substrate on which the pixel electrode is formed. FIG. 15 shows a cross-sectional structure taken along the line A-B in FIG. 16. FIG. 17 is a plan view of a side of a substrate on which the counter electrode is formed. Hereinafter, description is made with reference to these drawings.

FIG. 15 illustrates a state in which a substrate **600** provided with a TFT **628**, a pixel electrode **624** connected to the TFT **628**, and a storage capacitor portion **630** overlaps with a counter substrate **601** provided with a counter electrode **640** and the like, and a liquid crystal is injected therebetween.

At the position where the counter substrate **601** is provided with a spacer **642**, a light shielding film **632**, a first color film **634**, a second color film **636**, a third color film **638**, and the counter electrode **640** are formed. With this structure, the height of a projection **644** for controlling alignment of the liquid crystal and the height of the spacer **642** vary. An alignment film **648** is formed over the pixel electrode **624**. Similarly, the counter electrode **640** is provided with an alignment film **646**. A liquid crystal layer **650** is formed between the alignment films **646** and **648**.

Although a columnar spacer is used for the spacer **642** in this embodiment mode, a bead spacer may be dispersed. Further, the spacer **642** may be formed over the pixel electrode **624** provided over the substrate **600**.

The TFT **628**, the pixel electrode **624** connected to the TFT **628**, and the storage capacitor portion **630** are formed over the substrate **600**. The pixel electrode **624** is connected to a wiring **618** via a contact hole **623** which penetrates an insulating

film 620 which covers the TFT 628, the wiring, and the storage capacitor portion 630 and also penetrates an insulating film 622 which covers the insulating film 620. The thin film transistor shown in Embodiment Mode 1 can be used as the TFT 628 as appropriate. The storage capacitor portion 630 includes a first capacitor wiring 604 which is formed in a similar manner to a gate wiring 602 of the TFT 628, a gate insulating film 606, and a second capacitor wiring 617 which is formed in a similar manner to a wiring 616 and the wiring 618.

A liquid crystal element is formed by overlapping of the pixel electrode 624, the liquid crystal layer 650, and the counter electrode 640.

FIG. 16 shows a structure of the substrate 600 side. The pixel electrode 624 is formed using a material described in Embodiment Mode 1. The pixel electrode 624 is provided with a slit 625. The slit 625 is for controlling alignment of the liquid crystal.

A TFT 629, a pixel electrode 626 connected to the TFT 629, and a storage capacitor portion 631 shown in FIG. 16 can be formed in a similar manner to the TFT 628, the pixel electrode 624 and the storage capacitor portion 630, respectively. Both the TFT 628 and the TFT 629 are connected to the wiring 616. A pixel of this liquid crystal panel includes the pixel electrodes 624 and 626. Each of the pixel electrodes 624 and 626 is a sub-pixel.

FIG. 17 shows a structure of the counter substrate side. The counter electrode 640 is formed over the light shielding film 632. The counter electrode 640 is preferably formed using a material similar to the pixel electrode 624. The projection 644 for controlling alignment of the liquid crystal is formed over the counter electrode 640. Moreover, the spacer 642 is formed corresponding to the position of the light shielding film 632.

FIG. 18 shows an equivalent circuit of this pixel structure. Both the TFT 628 and the TFT 629 are connected to the gate wiring 602 and the wiring 616. In this case, when potentials of the capacitor wiring 604 and a capacitor wiring 605 are different from each other, operations of liquid crystal elements 651 and 652 can vary. That is, alignment of the liquid crystal is precisely controlled and a viewing angle is increased by individual control of potentials of the capacitor wirings 604 and 605.

When voltage is applied to the pixel electrode 624 provided with the slit 625, electric field distortion (an oblique electric field) is generated near the slit 625. The slit 625 and the projection 644 on the counter substrate 601 side are alternately arranged to be engaged with each other and thus, an oblique electric field is effectively generated to control alignment of the liquid crystal, so that a direction of alignment of the liquid crystal varies depending on location. That is, a viewing angle of the liquid crystal panel is increased by domain multiplication.

Next, another VA liquid crystal display device, which is different from the above-described device, is described with reference to FIGS. 19 to 22.

FIGS. 19 and 20 each show a pixel structure of the VA liquid crystal display device. FIG. 20 is a plan view of the substrate 600. FIG. 19 shows a cross-sectional structure along a line Y-Z in FIG. 20. Hereinafter, description is made with reference to these drawings.

In this pixel structure, a plurality of pixel electrodes is included in one pixel, and a TFT is connected to each pixel electrode. Each TFT is driven by a different gate signal. That is, a multi-domain pixel has a structure in which signals supplied to the respective pixel electrodes are individually controlled.

Via the contact hole 623, the pixel electrode 624 is connected to the TFT 628 using the wiring 618. Via a contact hole 627, the pixel electrode 626 is connected to the TFT 629 using a wiring 619. The gate wiring 602 of the TFT 628 and a gate wiring 603 of the TFT 629 are separated so that different gate signals can be given. In contrast, the wiring 616 functioning as a data line is used in common for the TFTs 628 and 629. A first capacitor is formed by a capacitor wiring 690, the gate insulating film 606 and the wiring 618. A second capacitor is formed by the capacitor wiring 690, the gate insulating film 606 and the wiring 619. As each of the TFTs 628 and 629, the thin film transistor shown in Embodiment Mode 1 can be used as appropriate.

The pixel electrodes 624 and 626 have different shapes and are separated by the slit 625. The pixel electrode 626 is formed so as to surround the external side of the pixel electrode 624 which is spread in a V-shape. Timing of voltage application is made to vary between the pixel electrodes 624 and 626 by the TFTs 628 and 629 in order to control alignment of the liquid crystal. FIG. 22 shows an equivalent circuit of this pixel structure. The TFT 628 is connected to the gate wiring 602. The TFT 629 is connected to the gate wiring 603. When different gate signals are supplied to the gate wirings 602 and 603, operation timings of the TFTs 628 and 629 can vary.

The counter substrate 601 is provided with the light shielding film 632, the second color film 636, and the counter electrode 640. Moreover, a planarization film 637 is formed between the second color film 636 and the counter electrode 640 to prevent alignment disorder of the liquid crystal. FIG. 21 shows a structure of the counter substrate side. A slit 641 is formed in the counter electrode 640, which is commonly used for different pixels. The slit 641 and the slit 625 on the pixel electrodes 624 and 626 side are alternately arranged to be engaged with each other; thus, an oblique electric field is effectively generated, and alignment of the liquid crystal can be controlled. Accordingly, a direction in which the liquid crystal is aligned can vary depending on location, and a viewing angle is increased.

A first liquid crystal element is formed by overlapping of the pixel electrode 624, the liquid crystal layer 650, and the counter electrode 640. A second liquid crystal element is formed by overlapping of the pixel electrode 626, the liquid crystal layer 650, and the counter electrode 640. This is a multi-domain structure in which the first liquid crystal element and the second liquid crystal element are included in one pixel.

Next, a horizontal electric field liquid crystal display device is described. The horizontal electric field mode is a method in which an electric field is horizontally applied to liquid crystal molecules in a cell, whereby the liquid crystal is driven to express a gray scale. By this method, a viewing angle can be increased to approximately 180 degrees. Hereinafter, a liquid crystal display device employing the horizontal electric field mode is described.

FIG. 23 illustrates a state in which the substrate 600 provided with the TFT 628 and the pixel electrode 624 connected to the TFT 628 overlaps with the counter substrate 601, and liquid crystal is injected therebetween. The counter substrate 601 is provided with the light shielding film 632, the second color film 636, the planarization film 637, and the like. Since the pixel electrode is provided on the substrate 600 side, it is not provided on the counter substrate 601 side. The liquid crystal layer 650 is formed between the substrate 600 and the counter substrate 601.

A first pixel electrode 607, the capacitor wiring 604 connected to the first pixel electrode 607, and the TFT 628 shown

in Embodiment Mode 1 are formed over the substrate **600**. The first pixel electrode **607** can be formed using a material similar to the pixel electrode **77** shown in Embodiment Mode 1. The first pixel electrode **607** is formed in a shape which is compartmentalized roughly in accordance with a pixel shape. Note that the gate insulating film **606** is formed over the first pixel electrode **607** and the capacitor wiring **604**.

The wirings **616** and **618** of the TFT **628** are formed over the gate insulating film **606**. The wiring **616** serves as a data line extending in one direction, through which a video signal is transmitted in a liquid crystal panel, and is connected to a source region **610** and serves as one of a source electrode and a drain electrode. The wiring **618** serves as the other of the source electrode and the drain electrode, and is connected to the second pixel electrode **624**.

The insulating film **620** is formed over the wirings **616** and **618**. Over the insulating film **620**, the second pixel electrode **624** connected to the wiring **618** via a contact hole **623** formed in the insulating film **620** is formed. The pixel electrode **624** is formed using a material similar to the pixel electrode **77** shown in Embodiment Mode 1.

In such a manner, the TFT **628** and the second pixel electrode **624** connected to the TFT **628** are formed over the substrate **600**. Note that a storage capacitor is formed between the first pixel electrode **607** and the second pixel electrode **624**.

FIG. **24** is a plan view illustrating a structure of the pixel electrode. The pixel electrode **624** is provided with the slit **625**. The slit **625** is for controlling alignment of the liquid crystal. In this case, an electric field is generated between the first pixel electrode **607** and the second pixel electrode **624**. The thickness of the gate insulating film **606** formed between the first pixel electrode **607** and the second pixel electrode **624** is 50 to 200 nm, which is sufficiently thin compared with the liquid crystal layer with a thickness of 2 to 10  $\mu\text{m}$ . Accordingly, an electric field is generated substantially in parallel (in a horizontal direction) to the substrate **600**. Alignment of the liquid crystal is controlled by the electric field. The liquid crystal molecules are horizontally rotated using the electric field which is approximately parallel to the substrate. In this case, since the liquid crystal molecules are parallel to the substrate in any state, there are few influences of contrast or the like depending on the angle of viewing; thus, the viewing angle is expanded. Further, since both the first pixel electrode **607** and the second pixel electrode **624** are light-transmitting electrodes, an aperture ratio can be increased.

Next, another example of a horizontal electric field liquid crystal display device is described.

FIGS. **25** and **26** each show a pixel structure of an IPS liquid crystal display device. FIG. **26** is a plan view. FIG. **25** shows a cross-sectional structure along a line A-B in FIG. **26**. Hereinafter, description is made with reference to these drawings.

FIG. **25** illustrates a state in which the substrate **600** provided with the TFT **628** and the pixel electrode **624** connected to the TFT **628** overlaps with the counter substrate **601**, and liquid crystal is injected therebetween. The counter substrate **601** is provided with the light shielding film **632**, the second color film **636**, the planarization film **637**, and the like. Since the pixel electrode is provided on the substrate **600** side, it is not provided on the counter substrate **601** side. The liquid crystal layer **650** is formed between the substrate **600** and the counter substrate **601**.

A common potential line **609** and the TFT **628** shown in Embodiment Mode 1 are formed over the substrate **600**. The common potential line **609** can be formed at the same time as the gate wiring **602** of the TFT **628**.

The wirings **616** and **618** of the TFT **628** are formed over the gate insulating film **606**. The wiring **616** serves as a data line extending in one direction, through which a video signal is transmitted in a liquid crystal panel, and is connected to the source region **610** and serves as one of a source electrode and a drain electrode. The wiring **618** serves as the other of the source electrode and the drain electrode, and is connected to the second pixel electrode **624**.

The second insulating film **620** is formed over the wirings **616** and **618**. Over the insulating film **620**, the pixel electrode **624** connected to the wiring **618** via the contact hole **623** formed in the insulating film **620** is formed. The pixel electrode **624** is formed using a material similar to the pixel electrode **77** shown in Embodiment Mode 1. Note that as shown in FIG. **26**, the pixel electrode **624** is formed so as to generate a horizontal electric field with a comb-shaped electrode which is formed at the same time as the common potential line **609**. Moreover, the pixel electrode **624** is formed so that comb-teeth portions of the pixel electrode **624** are alternately engaged with the comb-shaped electrode which is formed at the same time as the common potential line **609**.

Alignment of the liquid crystal is controlled by an electric field generated between a potential applied to the pixel electrode **624** and a potential of the common potential line **609**. The liquid crystal molecules are horizontally rotated using the electric field which is approximately parallel to the substrate. In this case, since the liquid crystal molecules are parallel to the substrate in any state, there are few influences of contrast or the like depending on the angle of viewing; thus, the viewing angle is expanded.

In such a manner, the TFT **628** and the pixel electrode **624** connected to the TFT **628** are formed over the substrate **600**. A storage capacitor is formed by the common potential line **609**, a capacitor electrode **615**, and the gate insulating film **606** provided therebetween. The capacitor electrode **615** and the pixel electrode **624** are connected via a contact hole **633**.

Next, a mode of a TN liquid crystal display device is described.

FIGS. **27** and **28** each show a pixel structure of a TN liquid crystal display device. FIG. **28** is a plan view. FIG. **27** shows a cross-sectional structure taken along the line A-B in FIG. **28**. Hereinafter, description is made with reference to these drawings.

The pixel electrode **624** is connected to the TFT **628** by the wiring **618** via the contact hole **623**. The wiring **616** functioning as a data line is connected to the TFT **628**. As the TFT **628**, any of the TFTs shown in Embodiment Mode 1 can be used.

The pixel electrode **624** is formed using the pixel electrode **77** shown in Embodiment Mode 1.

The counter substrate **601** is provided with the light shielding film **632**, the second color film **636**, and the counter electrode **640**. The planarization film **637** is formed between the second color film **636** and the counter electrode **640** to prevent alignment disorder of liquid crystal. The liquid crystal layer **650** is formed between the pixel electrode **624** and the counter electrode **640**.

A liquid crystal element is formed by overlapping of the pixel electrode **624**, the liquid crystal layer **650**, and the counter electrode **640**.

The counter electrode **640** can be formed using a material similar to the pixel electrode **624**. The liquid crystal element is formed by overlapping of the pixel electrode **624**, the liquid crystal layer **650**, and the counter electrode **640**.

In any of the liquid crystal display devices shown in FIGS. **15** to **28**, the substrate **600** or the counter substrate **601** may be provided with a color filter, a shielding film (a black matrix) for preventing disclination, or the like. Further, a polarizing

plate is attached to a surface of the substrate **600**, which is opposite to a surface of the substrate **600** on which the thin film transistor is formed. Moreover, a polarizing plate is attached to a surface of the counter substrate **601**, which is opposite to a surface of the substrate on which the counter electrode **640** is formed.

Through the above-described steps, the liquid crystal display device can be formed. Since a thin film transistor with small off current and highly-reliable electric properties is used in the liquid crystal display device of this embodiment mode, the liquid crystal display device has high contrast and high visibility. Further, since a thin film transistor in which a microcrystalline silicon film which is formed without a laser crystallization process is used for a channel formation region is used, a liquid crystal display device with high visibility can be formed with high productivity.

### Embodiment Mode 3

Next, a structure of a display panel, which is one mode of a liquid crystal display device of the present invention, is described below.

FIG. **12A** shows a mode of a display panel in which a signal line driver circuit **6013** which is separately formed is connected to a pixel portion **6012** formed over a substrate **6011**. The pixel portion **6012** and a scan line driver circuit **6014** are each formed using a thin film transistor in which a microcrystalline semiconductor film is used for a channel formation region. When the signal line driver circuit is formed using a transistor which has higher field-effect mobility compared with the thin film transistor in which the microcrystalline semiconductor film is used for the channel formation region, an operation of the signal line driver circuit which demands higher driving frequency than that of the scan line driver circuit can be stabilized. Note that the signal line driver circuit **6013** may be formed using a transistor in which a single crystalline semiconductor is used for a channel formation region, a thin film transistor in which a polycrystalline semiconductor is used for a channel formation region, or a transistor using SOI. The pixel portion **6012**, the signal line driver circuit **6013**, and the scan line driver circuit **6014** are each supplied with a potential of a power supply, a variety of signals, and the like via an FPC **6015**.

Note that both the signal line driver circuit and the scan line driver circuit may be formed over the same substrate as the pixel portion.

When a driver circuit is separately formed, a substrate over which the driver circuit is formed is not necessarily attached to a substrate over which a pixel portion is formed, and may be attached over an FPC, for example. FIG. **12B** shows a mode of a display panel in which a signal line driver circuit **6023** is separately formed and is connected to a pixel portion **6022** formed over a substrate **6021**. The pixel portion **6022** and the scan line driver circuit **6024** are each formed using a thin film transistor in which a microcrystalline semiconductor film is used for a channel formation region. The signal line driver circuit **6023** is connected to the pixel portion **6022** via an FPC **6025**. The pixel portion **6022**, the signal line driver circuit **6023**, and the scan line driver circuit **6024** are each supplied with a potential of a power supply, a variety of signals, and the like via the FPC **6025**.

Alternatively, only part of a signal line driver circuit or part of a scan line driver circuit may be formed over the same substrate as a pixel portion by using a thin film transistor in which a microcrystalline semiconductor film is used for a channel formation region, and the other part of the driver circuit may be separately formed and electrically connected

to the pixel portion. FIG. **12C** shows a mode of a display panel in which an analog switch **6033a** included in a signal line driver circuit is formed over a substrate **6031**, which is the same substrate as a pixel portion **6032** and a scan line driver circuit **6034**, and a shift register **6033b** included in the signal line driver circuit is separately formed over a different substrate and attached to the substrate **6031**. The pixel portion **6032** and the scan line driver circuit **6034** are each formed using a thin film transistor in which a microcrystalline semiconductor film is used for a channel formation region. The shift register **6033b** included in the signal line driver circuit is connected to the pixel portion **6032** via an FPC **6035**. The pixel portion **6032**, the signal line driver circuit, and the scan line driver circuit **6034** are each supplied with a potential of a power supply, a variety of signals, and the like via the FPC **6035**.

As shown in FIGS. **12A** to **12C**, in liquid crystal display devices of the present invention, all or a part of the driver circuit can be formed over the same substrate as the pixel portion, using the thin film transistor in which the microcrystalline semiconductor film is used for the channel formation region.

Note that a connection method of a substrate which is separately formed is not particularly limited, and a known COG method, wire bonding method, TAB method, or the like can be used. Further, a connection position is not limited to the positions shown in FIGS. **12A** to **12C** as long as electrical connection is possible. Moreover, a controller, a CPU, a memory, or the like may be formed separately and connected.

Note that a signal line driver circuit used in the present invention is not limited to a mode including only a shift register and an analog switch. In addition to the shift register and the analog switch, another circuit such as a buffer, a level shifter, or a source follower may be included. Moreover, the shift register and the analog switch are not necessarily provided. For example, a different circuit such as a decoder circuit by which a signal line can be selected may be used instead of the shift register, or a latch or the like may be used instead of the analog switch.

FIG. **30** is a block diagram of a liquid crystal display device of the present invention. The liquid crystal display device shown in FIG. **30** includes a pixel portion **700** including a plurality of pixels each provided with a liquid crystal element, a scan line driver circuit **702** which selects each pixel, and a signal line driver circuit **703** which controls input of a video signal to a selected pixel.

In FIG. **30**, the signal line driver circuit **703** includes a shift register **704** and an analog switch **705**. A clock signal (CLK) and a start pulse signal (SP) are input to the shift register **704**. When the clock signal (CLK) and the start pulse signal (SP) are input, a timing signal is generated in the shift register **704** and input to the analog switch **705**.

A video signal is supplied to the analog switch **705**. The analog switch **705** samples the video signal in accordance with the timing signal and supplies the resulting signal to a signal line of the next stage.

Next, a structure of the scan line driver circuit **702** is described. The scan line driver circuit **702** includes a shift register **706** and a buffer **707**. The scan line driver circuit **702** may also include a level shifter in some cases. In the scan line driver circuit **702**, when the clock signal (CLK) and the start pulse signal (SP) are input to the shift register **706**, a selection signal is generated. The generated selection signal is buffered and amplified by the buffer **707**, and the resulting signal is supplied to a corresponding scan line. Gates of transistors in pixels of one line are connected to the scan line. Further, since

the transistors in the pixels of one line should be turned on at the same time, a buffer through which large current can flow is used as the buffer 707.

In a full color liquid crystal display device, when video signals corresponding to R (red), G (green), or B (blue) are sequentially sampled and supplied to a corresponding signal line, the number of terminals for connecting the shift register 704 and the analog switch 705 corresponds to approximately  $\frac{1}{3}$  of the number of terminals for connecting the analog switch 705 and the signal line in the pixel portion 700. Accordingly, when the analog switch 705 and the pixel portion 700 are formed over the same substrate, the number of terminals used for connecting substrates which are separately formed can be suppressed compared with the case where the analog switch 705 and the pixel portion 700 are formed over different substrates; thus, occurrence probability of defective connection can be suppressed, and yield can be increased.

Note that although the scan line driver circuit 702 shown in FIG. 30 includes the shift register 706 and the buffer 707, the scan line driver circuit 702 may include the shift register 706.

Note that structures of the signal line driver circuit and the scan line driver circuit are not limited to the structures shown in FIG. 30, which are merely one mode of the liquid crystal display device of the present invention.

Next, one mode of a shift register including thin film transistors in which microcrystalline semiconductor films with the same polarity are used for channel formation regions is described with reference to FIGS. 31 and 32. FIG. 31 illustrates a structure of a shift register in this embodiment mode. The shift register shown in FIG. 31 includes a plurality of flip-flops (flip-flops 701-1 to 701-*n*). The shift register is operated by input of a first clock signal, a second clock signal, a start pulse signal, and a reset signal.

Connection relations of the shift register in FIG. 31 are described. In the *i*-th stage flip-flop 701-*i* (one of the flip-flops 701-1 to 701-*n*) in the shift register of FIG. 31, a first wiring 501 shown in FIG. 32 is connected to a seventh wiring 717-*(i-1)*; a second wiring 502 shown in FIG. 32 is connected to a seventh wiring 717-*(i+1)*; a third wiring 503 shown in FIG. 32 is connected to a seventh wiring 717-*i*; and a sixth wiring 506 shown in FIG. 32 is connected to a fifth wiring 715.

Further, a fourth wiring 504 shown in FIG. 32 is connected to a second wiring 712 in flip-flops of odd-numbered stages, and is connected to a third wiring 713 in flip-flops of even-numbered stages. A fifth wiring 505 shown in FIG. 32 is connected to a fourth wiring 714.

Note that the first wiring 501 of the first stage flip-flop 701-1 shown in FIG. 32 is connected to a first wiring 711. Moreover, the second wiring 502 of the *n*-th stage flip-flop 701-*n* shown in FIG. 32 is connected to a sixth wiring 716.

Note that the first wiring 711, the second wiring 712, the third wiring 713, and the sixth wiring 716 may be referred to as a first signal line, a second signal line, a third signal line, and a fourth signal line, respectively. The fourth wiring 714 and the fifth wiring 715 may be referred to as a first power supply line and a second power supply line, respectively.

Next, FIG. 32 shows details of the flip-flop shown in FIG. 31. A flip-flop shown in FIG. 32 includes a first thin film transistor 171, a second thin film transistor 172, a third thin film transistor 173, a fourth thin film transistor 174, a fifth thin film transistor 175, a sixth thin film transistor 176, a seventh thin film transistor 177, and an eighth thin film transistor 178. In this embodiment mode, each of the first thin film transistor 171, the second thin film transistor 172, the third thin film transistor 173, the fourth thin film transistor 174, the fifth thin film transistor 175, the sixth thin film transistor 176, the seventh thin film transistor 177, and the eighth thin film

transistor 178 is an n-channel transistor and is turned on when the gate-source voltage ( $V_{gs}$ ) exceeds the threshold voltage ( $V_{th}$ ).

Next, connection structures of the flip-flop shown in FIG. 32 are described below.

A first electrode (one of a source electrode and a drain electrode) of the first thin film transistor 171 is connected to the fourth wiring 504. A second electrode (the other of the source electrode and the drain electrode) of the first thin film transistor 171 is connected to the third wiring 503.

A first electrode of the second thin film transistor 172 is connected to the sixth wiring 506. A second electrode of the second thin film transistor 172 is connected to the third wiring 503.

A first electrode of the third thin film transistor 173 is connected to the fifth wiring 505. A second electrode of the third thin film transistor 173 is connected to a gate electrode of the second thin film transistor 172. A gate electrode of the third thin film transistor 173 is connected to the fifth wiring 505.

A first electrode of the fourth thin film transistor 174 is connected to the sixth wiring 506. A second electrode of the fourth thin film transistor 174 is connected to the gate electrode of the second thin film transistor 172. A gate electrode of the fourth thin film transistor 174 is connected to a gate electrode of the first thin film transistor 171.

A first electrode of the fifth thin film transistor 175 is connected to the fifth wiring 505. A second electrode of the fifth thin film transistor 175 is connected to the gate electrode of the first thin film transistor 171. A gate electrode of the fifth thin film transistor 175 is connected to the first wiring 501.

A first electrode of the sixth thin film transistor 176 is connected to the sixth wiring 506. A second electrode of the sixth thin film transistor 176 is connected to the gate electrode of the first thin film transistor 171. A gate electrode of the sixth thin film transistor 176 is connected to the gate electrode of the second thin film transistor 172.

A first electrode of the seventh thin film transistor 177 is connected to the sixth wiring 506. A second electrode of the seventh thin film transistor 177 is connected to the gate electrode of the first thin film transistor 171. A gate electrode of the seventh thin film transistor 177 is connected to the second wiring 502. A first electrode of the eighth thin film transistor 178 is connected to the sixth wiring 506. A second electrode of the eighth thin film transistor 178 is connected to the gate electrode of the second thin film transistor 172. A gate electrode of the eighth thin film transistor 178 is connected to the first wiring 501.

Note that the point at which the gate electrode of the first thin film transistor 171, the gate electrode of the fourth thin film transistor 174, the second electrode of the fifth thin film transistor 175, the second electrode of the sixth thin film transistor 176, and the second electrode of the seventh thin film transistor 177 are connected is referred to as a node 143. The point at which the gate electrode of the second thin film transistor 172, the second electrode of the third thin film transistor 173, the second electrode of the fourth thin film transistor 174, the gate electrode of the sixth thin film transistor 176, and the second electrode of the eighth thin film transistor 178 are connected is referred to as a node 144.

Note that the first wiring 501, the second wiring 502, the third wiring 503, and the fourth wiring 504 may be referred to as a first signal line, a second signal line, a third signal line, and a fourth signal line, respectively. The fifth wiring 505 and the sixth wiring 506 may be referred to as a first power supply line and a second power supply line, respectively.

FIG. 33 shows an example of a top plan view of the flip-flop shown in FIG. 32.

A conductive film 901 includes a portion functioning as the first electrode of the first thin film transistor 171, and is connected to the fourth wiring 504 through a wiring 951 which is formed at the same time as a pixel electrode.

A conductive film 902 includes a portion functioning as the second electrode of the first thin film transistor 171, and is connected to the third wiring 503 through a wiring 952 which is formed at the same time as the pixel electrode.

A conductive film 903 includes portions functioning as the gate electrode of the first thin film transistor 171 and the gate electrode of the fourth thin film transistor 174.

A conductive film 904 includes portions functioning as the first electrode of the second thin film transistor 172, the first electrode of the sixth thin film transistor 176, the first electrode of the fourth thin film transistor 174, and the first electrode of the eighth thin film transistor 178, and the conductive film 904 is connected to the sixth wiring 506.

A conductive film 905 includes a portion functioning as the second electrode of the second thin film transistor 172, and is connected to the third wiring 503 through a wiring 954 which is formed at the same time as the pixel electrode.

A conductive film 906 includes portions functioning as the gate electrode of the second thin film transistor 172 and the gate electrode of the sixth thin film transistor 176.

A conductive film 907 includes a portion functioning as the first electrode of the third thin film transistor 173, and is connected to the fifth wiring 505 through a wiring 955.

A conductive film 908 includes portions functioning as the second electrode of the third thin film transistor 173 and the second electrode of the fourth thin film transistor 174, and is connected to the conductive film 906 through a wiring 956 which is formed at the same time as the pixel electrode.

A conductive film 909 includes a portion functioning as the gate electrode of the third thin film transistor 173, and is connected to the fifth wiring 505 through the wiring 955.

A conductive film 910 includes a portion functioning as the first electrode of the fifth thin film transistor 175, and is connected to the fifth wiring 505 through a wiring 959 which is formed at the same time as the pixel electrode.

A conductive film 911 includes portions functioning as the second electrode of the fifth thin film transistor 175 and the second electrode of the seventh thin film transistor 177, and is connected to the conductive film 903 through a wiring 958 which is formed at the same time as the pixel electrode.

A conductive film 912 includes a portion functioning as the gate electrode of the fifth thin film transistor 175, and is connected to the first wiring 501 through a wiring 960 which is formed at the same time as the pixel electrode.

A conductive film 913 includes a portion functioning as the second electrode of the sixth thin film transistor 176, and is connected to the conductive film 903 through a wiring 957 which is formed at the same time as the pixel electrode.

A conductive film 914 includes a portion functioning as the gate electrode of the seventh thin film transistor 177, and is connected to the second wiring 502 through a wiring 962 which is formed at the same time as the pixel electrode.

A conductive film 915 includes a portion functioning as the gate electrode of the eighth thin film transistor 178, and is connected to the conductive film 912 through a wiring 961 which is formed at the same time as the pixel electrode.

A conductive film 916 includes a portion functioning as the second electrode of the eighth thin film transistor 178, and is connected to the conductive film 906 through a wiring 953 which is formed at the same time as the pixel electrode.

Note that parts of microcrystalline semiconductor films 981 to 988 function as channel formation regions of the first to eighth thin film transistors, respectively.

When the circuits as shown in FIGS. 30 to 32 include a thin film transistor in which a microcrystalline semiconductor is used for a channel formation region, the circuits can be operated at high speed. For example, in comparison of a thin film transistor in which a microcrystalline semiconductor film is used for a channel formation region with a thin film transistor in which an amorphous semiconductor film is used for a channel formation region, the field-effect mobility of the thin film transistor in which a microcrystalline semiconductor film is used for a channel formation region is higher, thus, driving frequency of a driver circuit (e.g., the shift register 706 in the scan line driver circuit 702) can be increased. Since the scan line driver circuit 702 can be operated at high speed, frame frequency can be increased or black frame insertion can be realized, for example.

When the frame frequency is increased, data for a screen is preferably generated in accordance with a direction of movement of an image. That is, motion compensation is preferably performed to interpolate data. When the frame frequency is increased and image data is interpolated in such a manner, display characteristics of moving images are improved, and smooth display can be performed. For example, when frame frequency is twice (e.g., 120 Hz or 100 Hz) or more, and preferably four times (e.g., 480 Hz or 400 Hz) or more, blurring and afterimages of moving images can be reduced. In this case, the driving frequency of the scan line driver circuit 702 is also increased to be operated; thus, the frame frequency can be increased.

When black frame insertion is performed, image data or data for black display is supplied to the pixel portion 700. Thus, such a display mode is closer to impulse driving, and afterimages can be reduced. In this case, the driving frequency of the scan line driver circuit 702 is also increased to be operated, and thus, black frame insertion can be performed.

In addition, when the channel width of the thin film transistor in the scan line driver circuit 702 is increased or a plurality of scan line driver circuits are provided, for example, higher frame frequency can be realized. For example, frame frequency can be eight times (e.g., 960 Hz or 800 Hz) or more. When a plurality of scan line driver circuits is provided, a scan line driver circuit for driving even-numbered scan lines is provided on one side and a scan line driver circuit for driving odd-numbered scan lines is provided on the opposite side; thus, increase in frame frequency can be realized. As an example, the channel width of the second thin film transistor 172 is preferably 300  $\mu\text{m}$  or more, and more preferably 1000  $\mu\text{m}$  or more.

When the circuits as shown in FIGS. 30 to 32 include a thin film transistor in which a microcrystalline semiconductor is used for a channel formation region, the layout area can be reduced. Accordingly, a frame of the liquid crystal display device can be reduced. For example, in comparison of a thin film transistor in which a microcrystalline semiconductor film is used for a channel formation region with a thin film transistor in which an amorphous semiconductor film is used for a channel formation region, the field-effect mobility of the thin film transistor in which a microcrystalline semiconductor film is used for a channel formation region is higher; thus, the channel width of the thin film transistor can be reduced. As a result, a frame of the liquid crystal display device can be narrowed. As an example, the channel width of the second thin film transistor 172 is preferably 3000  $\mu\text{m}$  or less, and more preferably 2000  $\mu\text{m}$  or less.

Note that in the second thin film transistor **172** of FIG. **32**, a period during which a low-level signal is output to the third wiring **503** is long. In this period, the second thin film transistor **172** is kept on. Therefore, extreme stress is applied to the second thin film transistor **172**, and characteristics of the transistor are likely to deteriorate. When the characteristics of the transistor deteriorate, the threshold voltage is gradually increased. Thus, a current value is decreased. In order to supply enough current even when the transistor deteriorates, the channel width of the second thin film transistor **172** is preferably large. Alternatively, compensation is preferably done so that a circuit operation is not affected even when the transistor deteriorates. For example, it is preferable that a transistor be provided in parallel with the second thin film transistor **172**, and the transistor and the second thin film transistor **172** be made to be alternately turned on, so that influence by deterioration is small.

In comparison of a thin film transistor in which a microcrystalline semiconductor film is used for a channel formation region with a thin film transistor in which an amorphous semiconductor film is used for a channel formation region, the thin film transistor in which a microcrystalline semiconductor film is used for a channel formation region is harder to deteriorate. Accordingly, when the microcrystalline semiconductor film is used for the channel formation region, the channel width of the thin film transistor can be reduced. Alternatively, the transistor can be normally operated without any circuit for compensation for deterioration. Accordingly, the layout area can be reduced.

Next, the appearance and a cross section of a liquid crystal display panel which is one mode of the liquid crystal display device of the present invention are described with reference to FIGS. **29A** and **29B**. FIG. **29A** is a top plan view of a panel. In the panel, a thin film transistor **4010** including a microcrystalline semiconductor film and a liquid crystal element **4013** which are formed over a first substrate **4001** are sealed between the first substrate **4001** and a second substrate **4006** by a sealing material **4005**. FIG. **29B** is a cross-sectional view along a line A-A' in FIG. **29A**.

The sealing material **4005** is provided so as to surround a pixel portion **4002** and a scan line driver circuit **4004** which are provided over the first substrate **4001**. The second substrate **4006** is provided over the pixel portion **4002** and the scan line driver circuit **4004**. Accordingly, the pixel portion **4002** and the scan line driver circuit **4004** are sealed together with liquid crystal **4008** by the first substrate **4001**, the sealing material **4005**, and the second substrate **4006**. Further, a signal line driver circuit **4003** formed using a polycrystalline semiconductor film over a different substrate is mounted on a region over the first substrate **4001**, which is different from the region surrounded by the sealing material **4005**. Note that in this embodiment mode, an example is described in which the signal line driver circuit including a thin film transistor in which a polycrystalline semiconductor film is used for a channel formation region is attached to the first substrate **4001**; however, a signal line driver circuit may be formed using a transistor in which a single crystalline semiconductor is used for a channel formation region and attached to a substrate. FIGS. **29A** and **29B** illustrate a thin film transistor **4009** formed using a polycrystalline semiconductor film, which is included in the signal line driver circuit **4003**.

Each of the pixel portion **4002** and the scan line driver circuit **4004** which are provided over the first substrate **4001** includes a plurality of thin film transistors. FIG. **29B** illustrates the thin film transistor **4010** included in the pixel portion **4002**. The thin film transistor **4010** corresponds to a thin

film transistor in which a microcrystalline semiconductor film is used for a channel formation region.

A pixel electrode **4030** included in the liquid crystal element **4013** is electrically connected to the thin film transistor **4010** through a wiring **4040**. A counter electrode **4031** of the liquid crystal element **4013** is formed on the second substrate **4006**. A portion where the pixel electrode **4030**, the counter electrode **4031**, and the liquid crystal **4008** overlap with each other corresponds to the liquid crystal element **4013**.

Note that for each of the first substrate **4001** and the second substrate **4006**, glass, metal (typically, stainless steel), ceramic, or plastic can be used. As plastic, a fiberglass-reinforced plastics (FRP) plate, a polyvinyl fluoride (PVF) film, a polyester film, or an acrylic resin film can be used. Moreover, a sheet in which aluminum foil is interposed between PVF films or polyester films can also be used.

A spherical spacer **4035** is provided to control a distance (a cell gap) between the pixel electrode **4030** and the counter electrode **4031**. Note that a spacer obtained by selective etching of an insulating film may be used.

A variety of signals and a potential supplied to the separately formed signal line driver circuit **4003**, the pixel portion **4002**, and the scan line driver circuit **4004** are supplied from an FPC **4018** through lead wirings **4014** and **4015**.

In this embodiment mode, a connection terminal **4016** is formed using the same conductive film as the pixel electrode **4030** included in the liquid crystal element **4013**. Further, the lead wirings **4014** and **4015** are formed using the same conductive film as the wiring **4040**.

The connection terminal **4016** is electrically connected to a terminal included in the FPC **4018** through an anisotropic conductive film **4019**.

Note that although not shown, a liquid crystal display device shown in this embodiment mode includes an alignment film and a polarizing plate, and may also include a color filter and/or a shielding film.

FIGS. **29A** and **29B** illustrate an example in which the signal line driver circuit **4003** is separately formed and attached to the first substrate **4001**; however, this embodiment mode is not limited to this structure. A scan line driver circuit may be separately formed and attached to a substrate, or only part of a signal line driver circuit or part of a scan line driver circuit may be separately formed and attached to a substrate.

This embodiment mode can be implemented in combination with any of the structures described in the other embodiment modes.

#### Embodiment Mode 4

The liquid crystal display device obtained according to the present invention can be used for an active matrix liquid crystal module. That is, the present invention can be implemented in any of electronic devices having a display portion in which such an active matrix liquid crystal module is incorporated.

Examples of such electronic devices include cameras such as a video camera and a digital camera, a head-mounted display (a goggle-type display), a car navigation system, a projector, a car stereo, a personal computer, and a portable information terminal (e.g., a mobile computer, a cellular phone, and an e-book reader). FIGS. **13A** to **13C** show examples of such electronic devices.

FIG. **13A** shows a television device. The television device can be completed by incorporating a display module into a housing as shown in FIG. **13A**. A display panel with an FPC attached is also referred to as a display module. A main screen **2003** is formed using the display module, and other accesso-

ries such as a speaker portion **2009** and an operation switch are provided. Thus, the television device can be completed.

As shown in FIG. **13A**, a display panel **2002** using a liquid crystal element is incorporated into a housing **2001**. The television device can receive general TV broadcast by a receiver **2005**, and can be connected to a wired or wireless communication network via a modem **2004** so that one-way (from a sender to a receiver) or two-way (between a sender and a receiver or between receivers) information communication can be performed. The television device can be operated by a switch incorporated into the housing or a separate remote control unit **2006**. The remote control unit may include a display portion **2007** for displaying information to be output.

Further, the television device may include a sub screen **2008** formed using a second display panel for displaying channels, sound volume, and the like, in addition to the main screen **2003**. In this structure, the main screen **2003** may be formed using a liquid crystal display panel with an excellent viewing angle, and the sub screen may be formed using a liquid crystal display panel in which display is performed with low power consumption. Alternatively, when reduction in power consumption is prioritized, a structure may be employed in which the main screen **2003** is formed using a liquid crystal display panel, the sub screen is formed using a liquid crystal display panel, and the sub screen can be turned on and off.

FIG. **14** is a block diagram of a main structure of a television device. A display panel **900** is provided with a pixel portion **921**. A signal line driver circuit **922** and a scan line driver circuit **923** may be mounted on the display panel **900** by a COG method.

As for other external circuits, the television device includes a video signal amplifier circuit **925** which amplifies a video signal among signals received by a tuner **924**; a video signal processing circuit **926** which converts a signal output from the video signal amplifier circuit **925** into a color signal corresponding to each color of red, green, and blue; a control circuit **927** which converts the video signal into an input specification of a driver IC; and the like. The control circuit **927** outputs signals to each of the scan line side and the signal line side. When digital driving is performed, a structure may be employed in which a signal dividing circuit **928** is provided on the signal line side and an input digital signal is divided into *m* signals to be supplied.

Among the signals received by the tuner **924**, an audio signal is transmitted to an audio signal amplifier circuit **929**, and an output thereof is supplied to a speaker **933** through an audio signal processing circuit **930**. A control circuit **931** receives control information on receiving station (receiving frequency) and volume from an input portion **932** and transmits a signal to the tuner **924** and the audio signal processing circuit **930**.

It is needless to say that the present invention is not limited to a television device and can be applied to a variety of uses, such as a monitor of a personal computer, a large display medium such as an information display board at the train station, the airport, or the like, or an advertisement display board on the street.

FIG. **13B** shows an example of a cellular phone **2201**. The cellular phone **2201** includes a display portion **2202**, an operation portion **2203**, and the like. When the liquid crystal display device described in the above-described embodiment mode is used for the display portion **2202**, mass productivity can be increased.

A portable computer shown in FIG. **13C** includes a main body **2401**, a display portion **2402**, and the like. When the

liquid crystal display device described in the above-described embodiment mode is used for the display portion **2402**, mass productivity can be increased.

#### Embodiment 1

A microcrystalline silicon film was formed, and results of measuring the crystallinity of the film by Raman spectroscopy are shown in FIGS. **34A** and **34B**.

The microcrystalline silicon film was formed under conditions where the RF power frequency was 13.56 MHz, the film formation temperature was 280° C., the flow rate ratio of hydrogen to a silane gas was 100:1, and the pressure was 280 Pa. FIG. **34A** shows Raman scattering spectra and shows a comparison of measurement results of a microcrystalline silicon film that was formed with the amount of power of an RF power source being 100 W and a microcrystalline silicon film with 300 W.

Note that the crystalline peak position of single crystalline silicon is at 521 cm<sup>-1</sup>. Note that, needless to say, the crystalline peak of amorphous silicon cannot be observed, and only a broad peak is measured at 480 cm<sup>-1</sup> as illustrated in FIG. **34B**. The microcrystalline silicon film of this specification refers to one whose crystalline peak position can be observed at greater than or equal to 481 cm<sup>-1</sup> and less than 520 cm<sup>-1</sup> when measured with a Raman spectrometer.

The crystalline peak position of the microcrystalline silicon film which was formed with the amount of power of an RF power source being 100 W is at 518.6 cm<sup>-1</sup>; the full width at half maximum (FWHM) is 11.9 cm<sup>-1</sup>; and the crystalline/amorphous peak intensity ratio ( $I_c/I_a$ ) is 4.1.

The crystalline peak position of the microcrystalline silicon film that was formed with the amount of power of an RF power source being 300 W is at 514.8 cm<sup>-1</sup>; the full width at half maximum (FWHM) is 18.7 cm<sup>-1</sup>; and the crystalline/amorphous peak intensity ratio ( $I_c/I_a$ ) is 4.4.

As illustrated in FIG. **34A**, there is a crystal peak shift and a large difference in full width at half maximum depending on RF power. It can be considered that this is because the grain size is likely to be small, because ion bombardment becomes significant at high power and the growth of grains is inhibited. In addition, because the power frequency of a CVD apparatus, with which the microcrystalline silicon film used for measurement of FIG. **34A** was formed, is 13.56 MHz, the crystalline/amorphous peak intensity ratio ( $I_c/I_a$ ) is 4.1 or 4.4. However, it is also confirmed that the crystalline/amorphous peak intensity ratio ( $I_c/I_a$ ) can be 6 if the RF power frequency is 27 MHz. Accordingly, the crystalline/amorphous peak intensity ratio ( $I_c/I_a$ ) can be further increased when the RF power frequency is higher than 27 MHz, for example, when the RF power frequency is 2.45 GHz.

#### Embodiment 2

In this embodiment, results of device simulation of transistor characteristics and electron density distribution of the thin film transistor of the present invention are described. For device simulation, the device simulator "ATLAS" made by Silvaco is used.

FIG. **35** shows a device structure. An insulating substrate **2301** is assumed to be a glass substrate (with a thickness of 0.5 μm) which contains silicon oxide (with a dielectric constant of 4.1) as its main component. Note that, although the thickness of the insulating substrate **2301** is often 0.5 mm, 0.7 mm, or the like in a practical manufacturing process, the thickness is defined to such a sufficient thickness that an electric field at

the lower surface of the insulating substrate **2301** does not affect thin film transistor characteristics.

Over the insulating substrate **2301**, a gate electrode **2303** formed of molybdenum (with a thickness of 150 nm) is stacked. The work function of molybdenum is 4.6 eV.

Over the gate electrode **2303**, a gate insulating film **2305** having a stacked structure of a silicon nitride film (with a dielectric constant of 7.0 and a thickness of 110 nm) and a silicon oxynitride film (with a dielectric constant of 4.1 and a thickness of 110 nm) is stacked.

Over the gate insulating film **2305**, a  $\mu\text{-Si}$  film **2307** and an a-Si film **2309** are stacked. Here, conditions are separately set for a stacked layer of the  $\mu\text{-Si}$  film **2307** with a thickness of 0 nm and the a-Si film **2309** with a thickness of 100 nm, a stacked layer of the  $\mu\text{-Si}$  film **2307** with a thickness of 10 nm and the a-Si film **2309** with a thickness of 90 nm, a stacked layer of the  $\mu\text{-Si}$  film **2307** with a thickness of 50 nm and the a-Si film **2309** with a thickness of 50 nm, a stacked layer of the  $\mu\text{-Si}$  film **2307** with a thickness of 90 nm and the a-Si film **2309** with a thickness of 10 nm, and a stacked layer of the  $\mu\text{-Si}$  film **2307** with a thickness of 100 nm and the a-Si film **2309** with a thickness of 0 nm.

In addition, each of regions of the a-Si film **2309** overlapping with a first a-Si( $n^+$ ) film **2311** and a second a-Si( $n^+$ ) film **2313** has another thickness of 50 nm in addition to the above-described thickness. That is, a part of the a-Si film **2309** in a region where the first a-Si( $n^+$ ) film **2311** and the second a-Si( $n^+$ ) film **2313** are not formed is etched by 50 nm and has a concave portion.

Over the a-Si film **2309**, the first a-Si( $n^+$ ) film **2311** (with a thickness of 50 nm) and the second a-Si( $n^+$ ) film **2313** (with a thickness of 50 nm) are stacked. In the thin film transistor shown in FIG. **35**, the distance between the first a-Si( $n^+$ ) film **2311** and the second a-Si( $n^+$ ) film **2313** corresponds to a channel length L. Here, the channel length L is 6  $\mu\text{m}$ . The channel width W is 15  $\mu\text{m}$ .

Over the first a-Si( $n^+$ ) film **2311** and the second a-Si( $n^+$ ) film **2313**, a source electrode **2315** and a drain electrode **2317**, each of which is formed of molybdenum (Mo) (with a thickness of 300 nm), are formed, respectively. A contact between the source electrode **2315** and the first a-Si( $n^+$ ) film **2311** and that between the drain electrode **2317** and the second a-Si( $n^+$ ) film **2313** are defined as ohmic contacts.

FIG. **36** shows results of DC characteristics ( $V_g$ - $I_d$  characteristics,  $V_d=14$  V) when device simulation of the thin film transistor shown in FIG. **35** is performed with the thicknesses of the  $\mu\text{-Si}$  film and the a-Si film being changed variously. FIGS. **37A** and **37B** each show electron concentration distribution in the thin film transistor when the  $\mu\text{-Si}$  film **2307** has a thickness of 10 nm and the a-Si film has a thickness of 90 nm. FIG. **37A** shows results of electron concentration distribution when the thin film transistor is in an on state ( $V_g=+10$  V,  $V_d=14$  V), and FIG. **37B** shows results of electron concentration distribution when the thin film transistor is in an off state ( $V_g=-10$  V,  $V_d=14$  V).

It can be seen from FIG. **36** that, as the thickness of the a-Si film is increased, the off current is decreased. In addition, when the thickness of the a-Si film is 50 nm or more, the drain current when  $V_g$  is  $-20$  V can be made to be lower than  $1 \times 10^{-13}$  A.

It can also be seen that, as the thickness of the  $\mu\text{-Si}$  film is increased, the on current is increased. In addition, when the thickness of the  $\mu\text{-Si}$  film is set to be 10 nm or more, the drain current when  $V_g$  is 20 V can be made to be  $1 \times 10^{-5}$  A or more.

It can be seen from FIG. **37A** that, in the on state, the  $\mu\text{-Si}$  film has a higher electron density than the a-Si film. That is, the  $\mu\text{-Si}$  film with high electric conductivity has a high

electron density; thus, it can be seen that, in the on state, electrons are easy to flow and the drain current is increased.

It can be seen from FIG. **37B** that, in the off state, the a-Si film has a higher electron density than the  $\mu\text{-Si}$  film. That is, the a-Si film with low electric conductivity has a high electron density; thus, it can be seen that, in the off state, electrons are difficult to flow and the drain current is equivalent to that of a thin film transistor in which an a-Si film is used as a channel formation region.

It can be seen from the above description that a thin film transistor as illustrated in FIG. **35**, in which a  $\mu\text{-Si}$  film is formed over a gate insulating film, an a-Si film is formed over the  $\mu\text{-Si}$  film, and source and drain regions are formed over the a-Si film, can be made to have a lower off current and a higher on current.

This application is based on Japanese Patent Applications serial nos. 2007-179092 filed with Japan Patent Office on Jul. 6, 2007, the entire contents of which are hereby incorporated by reference.

What is claimed is:

1. A liquid crystal display device comprising:

a gate electrode;  
a gate insulating film formed over the gate electrode;  
a microcrystalline semiconductor film formed over the gate insulating film;  
a buffer layer which is formed over the microcrystalline semiconductor film and has a concave portion;  
source and drain regions formed over the buffer layer; and  
source and drain electrodes in contact with the source and drain regions,  
wherein:

the source and drain electrodes are not overlapped with end portions of the microcrystalline semiconductor film and the source and drain regions; and  
end portions of the source and drain regions which are overlapped with the gate electrode are aligned with side faces of the concave portion of the buffer layer.

2. The liquid crystal display device according to claim 1, wherein the buffer layer is formed of an amorphous semiconductor film.

3. The liquid crystal display device according to claim 1, wherein the buffer layer is formed of an amorphous semiconductor film containing nitrogen.

4. The liquid crystal display device according to claim 1, wherein the buffer layer is formed of an amorphous semiconductor film containing hydrogen.

5. The liquid crystal display device according to claim 1, wherein the buffer layer is formed of an amorphous semiconductor film containing fluorine, chlorine, bromine, or iodine.

6. A liquid crystal display device comprising:

a gate electrode;  
a gate insulating film formed over the gate electrode;  
a microcrystalline semiconductor film formed over the gate insulating film;  
a buffer layer which is formed over the microcrystalline semiconductor film and has a concave portion;  
source and drain regions formed over the buffer layer; and  
source and drain electrodes in contact with the source and drain regions,  
wherein:

a part of the source and drain regions is in contact with the source and drain electrodes;

the other part of the source and drain regions is not in contact with the source and drain electrodes;

the buffer layer is exposed outside the source and drain electrodes;

the source and drain electrodes are not overlapped with end portions of the microcrystalline semiconductor film and the source and drain regions; and  
 end portions of the source and drain regions which are overlapped with the gate electrode are aligned with side faces of the concave portion of the buffer layer.

7. The liquid crystal display device according to claim 6, wherein the buffer layer is formed of an amorphous semiconductor film.

8. The liquid crystal display device according to claim 6, wherein the buffer layer is formed of an amorphous semiconductor film containing nitrogen.

9. The liquid crystal display device according to claim 6, wherein the buffer layer is formed of an amorphous semiconductor film containing hydrogen.

10. The liquid crystal display device according to claim 6, wherein the buffer layer is formed of an amorphous semiconductor film containing fluorine, chlorine, bromine, or iodine.

11. A liquid crystal display device comprising:  
 a gate electrode;  
 a gate insulating film formed over the gate electrode;  
 a microcrystalline semiconductor film formed over the gate insulating film;  
 a buffer layer which is formed over the microcrystalline semiconductor film and has a concave portion;  
 source and drain regions formed over the buffer layer;  
 source and drain electrodes in contact with the source and drain regions;  
 an insulating film in contact with the source and drain electrodes, a part of the source and drain regions, and a part of the buffer layer;  
 a pixel electrode formed over the insulating film and connected to one of the source and drain electrodes through a contact hole formed in the insulating film; and  
 a liquid crystal adjacent to the pixel electrode;  
 wherein:  
 the source and drain electrodes are not overlapped with end portions of the microcrystalline semiconductor film and the source and drain regions; and  
 end portions of the source and drain regions which are overlapped with the gate electrode are aligned with side faces of the concave portion of the buffer layer.

12. The liquid crystal display device according to claim 11, wherein the buffer layer is formed of an amorphous semiconductor film.

13. The liquid crystal display device according to claim 11, wherein the buffer layer is formed of an amorphous semiconductor film containing nitrogen.

14. The liquid crystal display device according to claim 11, wherein the buffer layer is formed of an amorphous semiconductor film containing hydrogen.

15. The liquid crystal display device according to claim 11, wherein the buffer layer is formed of an amorphous semiconductor film containing fluorine, chlorine, bromine, or iodine.

16. A liquid crystal display device comprising:  
 a gate electrode;  
 a gate insulating film formed over the gate electrode;  
 a microcrystalline semiconductor film formed over the gate insulating film;  
 a buffer layer which is formed over the microcrystalline semiconductor film and has a concave portion;  
 source and drain regions formed over the buffer layer;  
 source and drain electrodes in contact with the source and drain regions;

an insulating film in contact with the source and drain electrodes, a part of the source and drain regions, and a part of the buffer layer;  
 a pixel electrode formed over the insulating film and connected to one of the source and drain electrodes through a contact hole formed in the insulating film; and  
 a liquid crystal adjacent to the pixel electrode;  
 wherein:  
 a part of the source and drain regions is in contact with the source and drain electrodes;  
 the other part of the source and drain regions is not in contact with the source and drain electrodes;  
 the buffer layer is exposed outside of the source and drain electrodes; and  
 end portions of the source and drain regions which are formed over the gate electrode are aligned with side faces of the concave portion of the buffer layer.

17. The liquid crystal display device according to claim 16, wherein the buffer layer is formed of an amorphous semiconductor film.

18. The liquid crystal display device according to claim 16, wherein the buffer layer is formed of an amorphous semiconductor film containing nitrogen.

19. The liquid crystal display device according to claim 16, wherein the buffer layer is formed of an amorphous semiconductor film containing hydrogen.

20. The liquid crystal display device according to claim 16, wherein the buffer layer is formed of an amorphous semiconductor film containing fluorine, chlorine, bromine, or iodine.

21. A liquid crystal display device comprising:  
 a gate electrode;  
 a gate insulating film formed over the gate electrode;  
 a microcrystalline semiconductor film formed over the gate insulating film;  
 a buffer layer formed over the microcrystalline semiconductor film;  
 source and drain regions formed over the buffer layer; and  
 source and drain electrodes formed on the source and drain regions,  
 wherein:  
 the source and drain regions extend beyond outer side edges of the source and drain electrodes,  
 a portion of the buffer layer between the source and drain regions is thinned, and  
 the buffer layer extends beyond outer side edges of the source and drain regions.

22. The liquid crystal display device according to claim 21, wherein the buffer layer is formed of an amorphous semiconductor film.

23. The liquid crystal display device according to claim 21, wherein the buffer layer is formed of an amorphous semiconductor film containing nitrogen.

24. The liquid crystal display device according to claim 21, wherein the buffer layer is formed of an amorphous semiconductor film containing hydrogen.

25. The liquid crystal display device according to claim 21, wherein the buffer layer is formed of an amorphous semiconductor film containing fluorine, chlorine, bromine, or iodine.

26. The liquid crystal display device according to claim 21, wherein the portion of the buffer layer has side edges aligned with inner side edges of the source and drain regions.

专利名称(译)	液晶显示装置		
公开(公告)号	<a href="#">US7738050</a>	公开(公告)日	2010-06-15
申请号	US12/213729	申请日	2008-06-24
[标]申请(专利权)人(译)	株式会社半导体能源研究所		
申请(专利权)人(译)	半导体能源研究所有限公司.		
当前申请(专利权)人(译)	半导体能源研究所有限公司		
[标]发明人	YAMAZAKI SHUNPEI SUZUKI YUKIE KUWABARA HIDEAKI KIMURA HAJIME		
发明人	YAMAZAKI, SHUNPEI SUZUKI, YUKIE KUWABARA, HIDEAKI KIMURA, HAJIME		
IPC分类号	G02F1/136 H01L27/14		
CPC分类号	G02F1/1368 H01L27/1214 H01L29/04 H01L27/1288 H01L29/78696 G02F1/136286 G02F1/133345 H01L27/1222 H01L29/78678 H01L29/66765 H01L29/458 H01L29/4908 G02F1/1343 G02F1/136209 H01L29/41733 H01L29/78618 G02F1/1339 G02F1/134309		
优先权	2007179092 2007-07-06 JP		
其他公开文献	US20090009677A1		
外部链接	<a href="#">Espacenet</a> <a href="#">USPTO</a>		

摘要(译)

本发明提供一种制造具有高批量生产率的液晶显示装置的方法，该液晶显示装置具有高可靠性，具有优异的电特性的薄膜晶在具有反交错薄膜晶体管的液晶显示装置中，如下形成反交错薄膜晶体管：在栅电极上形成栅极绝缘膜；在栅极绝缘膜上形成用作沟道形成区的微晶半导体膜；在微晶半导体膜上形成缓冲层；在缓冲层上形成一对源区和漏区；形成与源区和漏区接触的一对源电极和漏电极，以暴露源区和漏区的一部分。

