



US 20090167972A1

(19) **United States**

(12) **Patent Application Publication**  
**Hong**

(10) **Pub. No.: US 2009/0167972 A1**

(43) **Pub. Date: Jul. 2, 2009**

(54) **LIQUID CRYSTAL DISPLAY DEVICE**

(30) **Foreign Application Priority Data**

(76) Inventor: **Jin Cheol Hong, Kumi-shi (KR)**

Mar. 28, 2003 (KR) ..... 10-2003-0019532

**Publication Classification**

Correspondence Address:  
**MCKENNA LONG & ALDRIDGE LLP**  
**1900 K STREET, NW**  
**WASHINGTON, DC 20006 (US)**

(51) **Int. Cl.**  
**G02F 1/1343** (2006.01)  
**G09G 3/36** (2006.01)

(52) **U.S. Cl.** ..... **349/37; 349/139**

(21) Appl. No.: **12/379,545**

(57) **ABSTRACT**

(22) Filed: **Feb. 24, 2009**

A liquid crystal display device for eliminating a vertical dimming phenomenon to improve a picture quality of a liquid crystal display panel is disclosed. In the device, first and second data lines are supplied with data. A first pixel electrode is spaced at a desired distance from the first data line. A second pixel electrode is spaced, by a distance different from said distance between the first data line and the first pixel electrode, from the second data line.

**Related U.S. Application Data**

(62) Division of application No. 10/811,141, filed on Mar. 29, 2004, now Pat. No. 7,511,791.

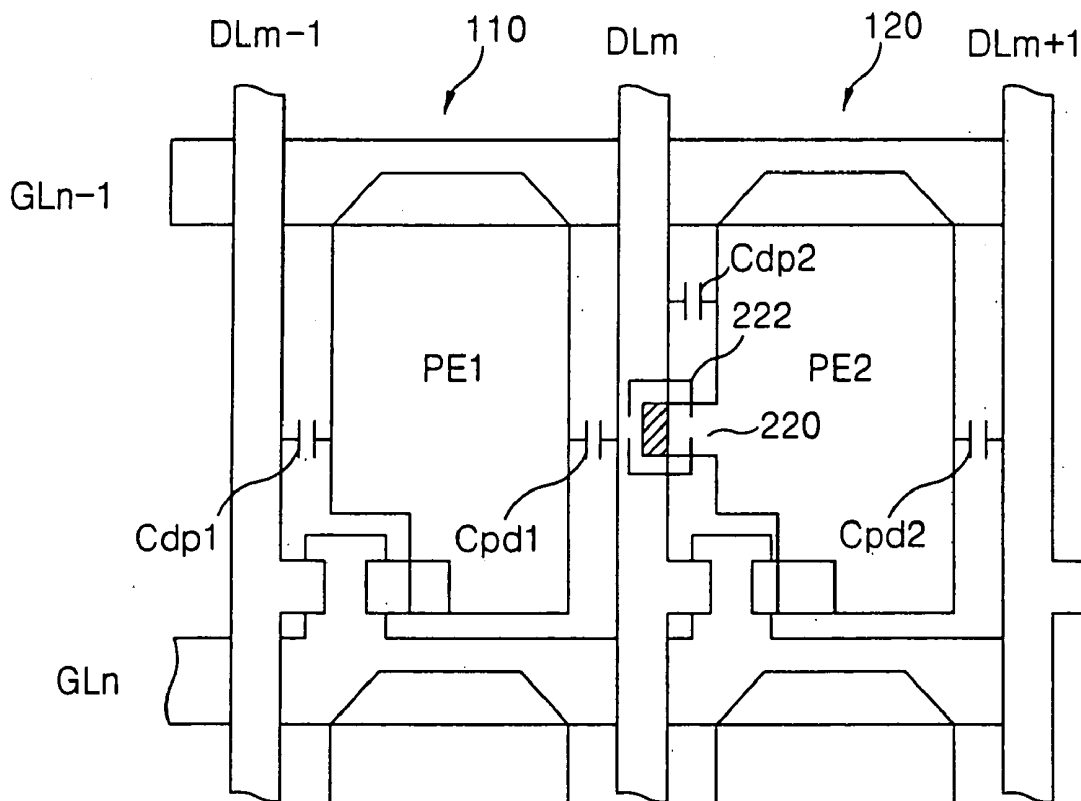

# FIG. 1A

## RELATED ART

R G B R G B R G B R G B

+	+	-	-	+	+	-	-	+	+	-	-
-	-	+	+	-	-	+	+	-	-	+	+
+	+	-	-	+	+	-	-	+	+	-	-
-	-	+	+	-	-	+	+	-	-	+	+

[ODD FRAME]

# FIG. 1B

## RELATED ART

R G B R G B R G B R G B

-	-	+	+	-	-	+	+	-	-	+	+
+	+	-	-	+	+	-	-	+	+	-	-
-	-	+	+	-	-	+	+	-	-	+	+
+	+	-	-	+	+	-	-	+	+	-	-

[EVEN FRAME]

FIG. 2  
RELATED ART

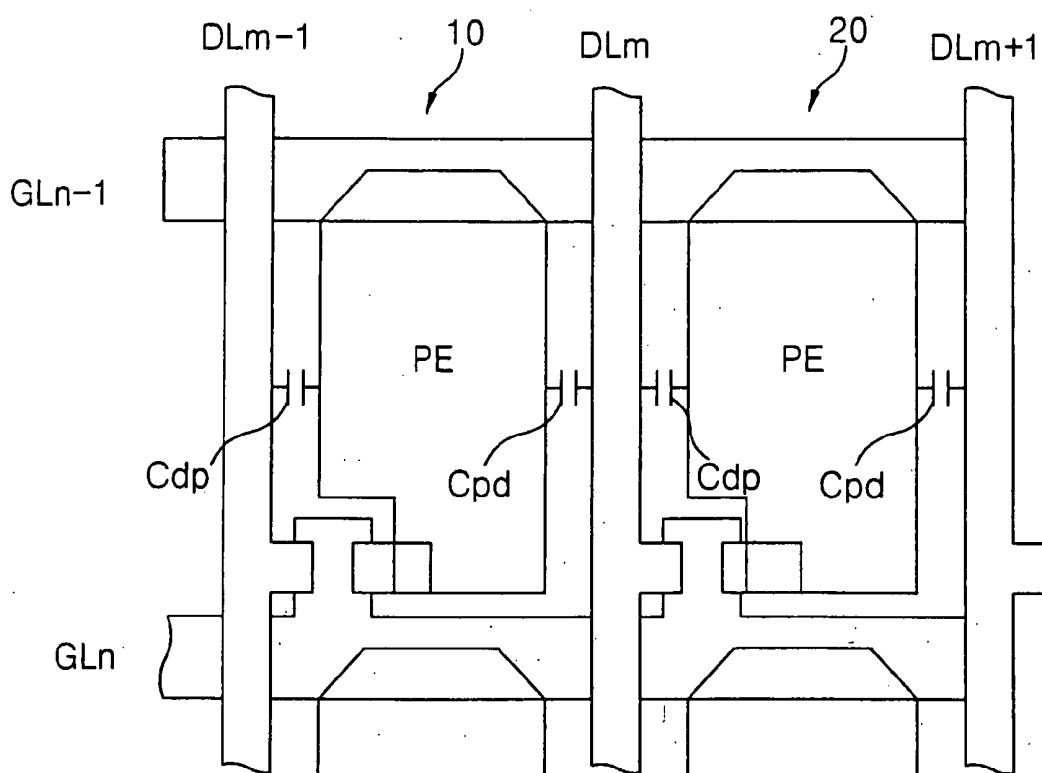

FIG. 3  
RELATED ART

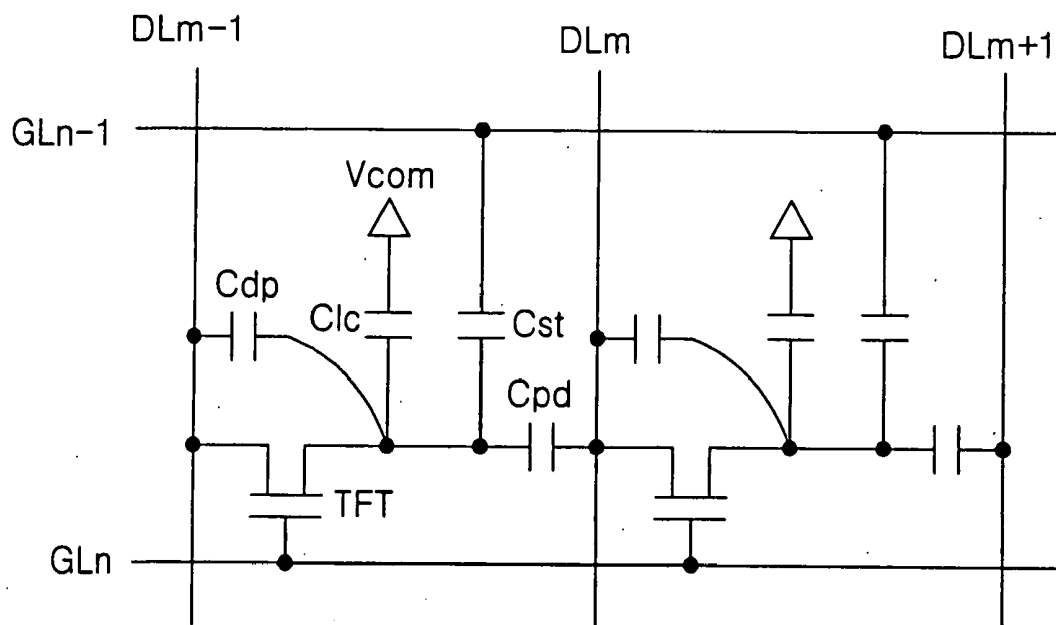
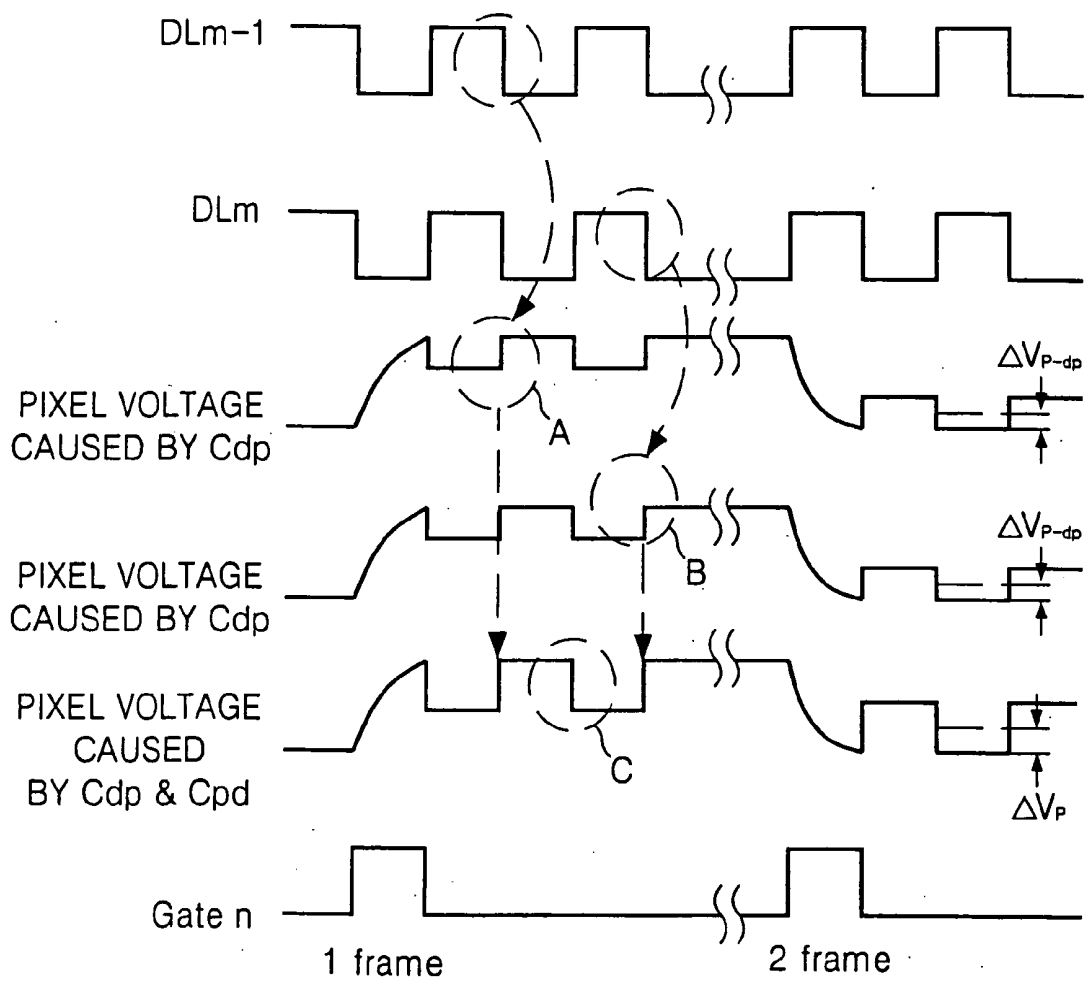

FIG. 4  
RELATED ART



# FIG. 5

RELATED ART

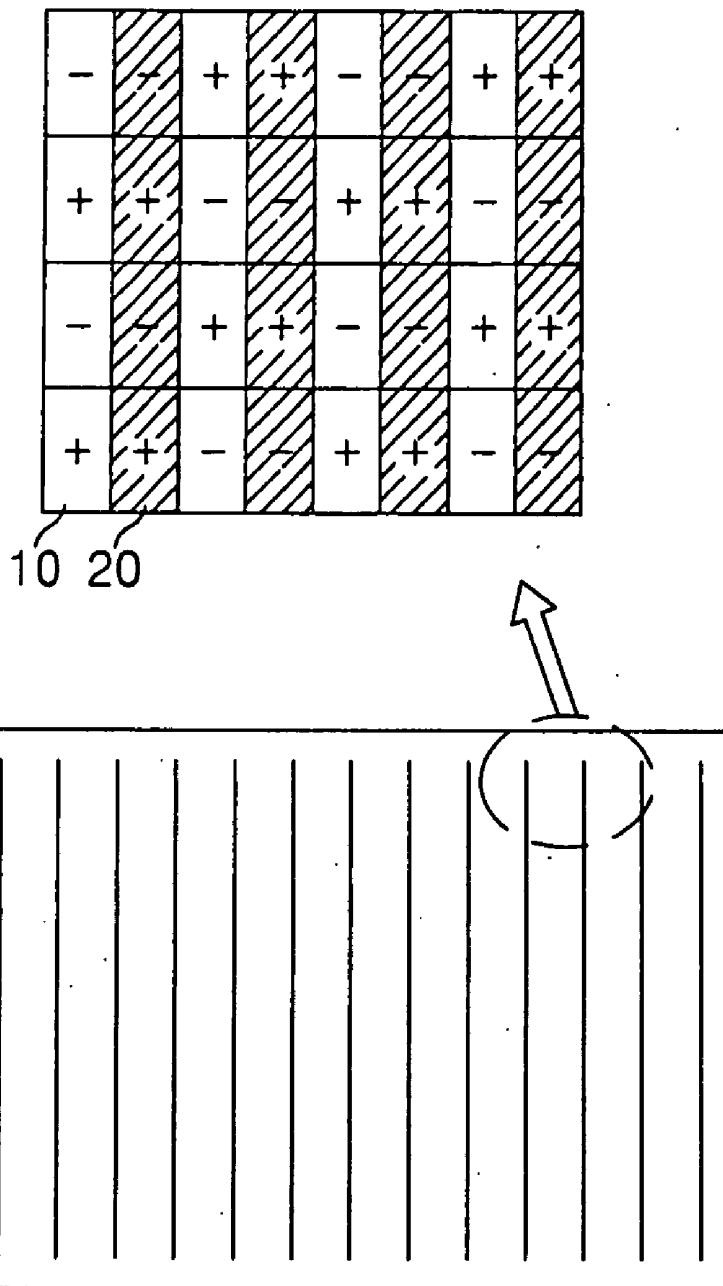

FIG. 6

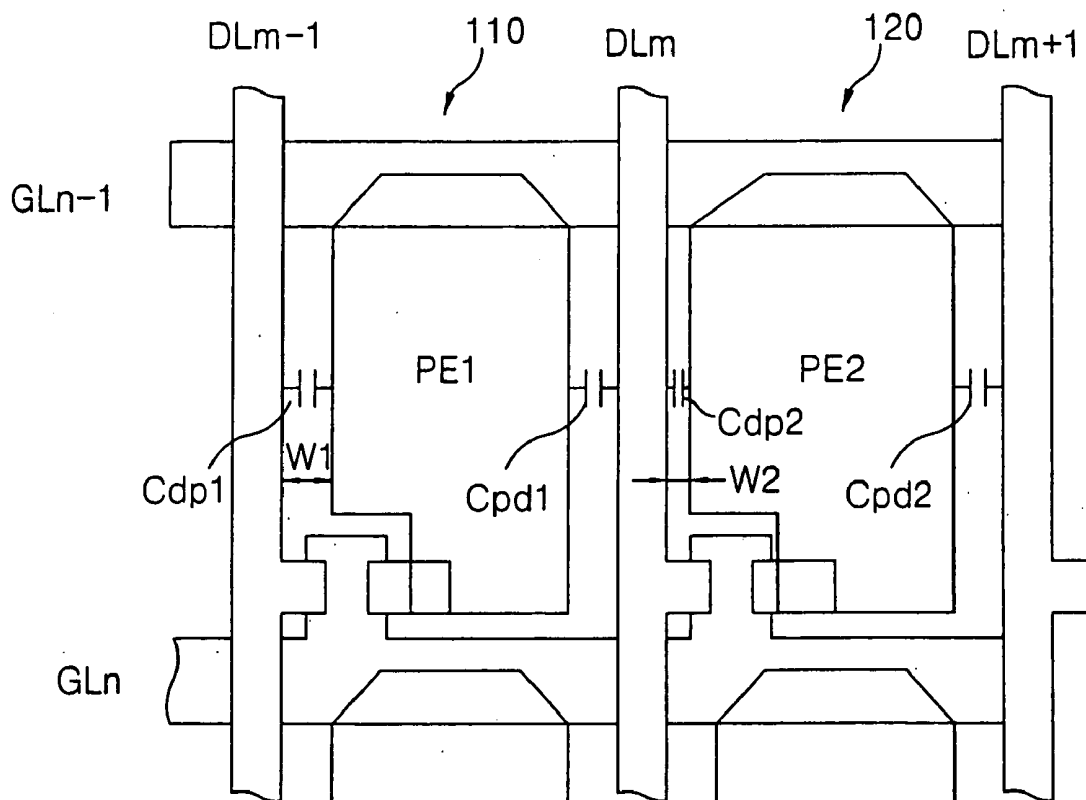

FIG. 7

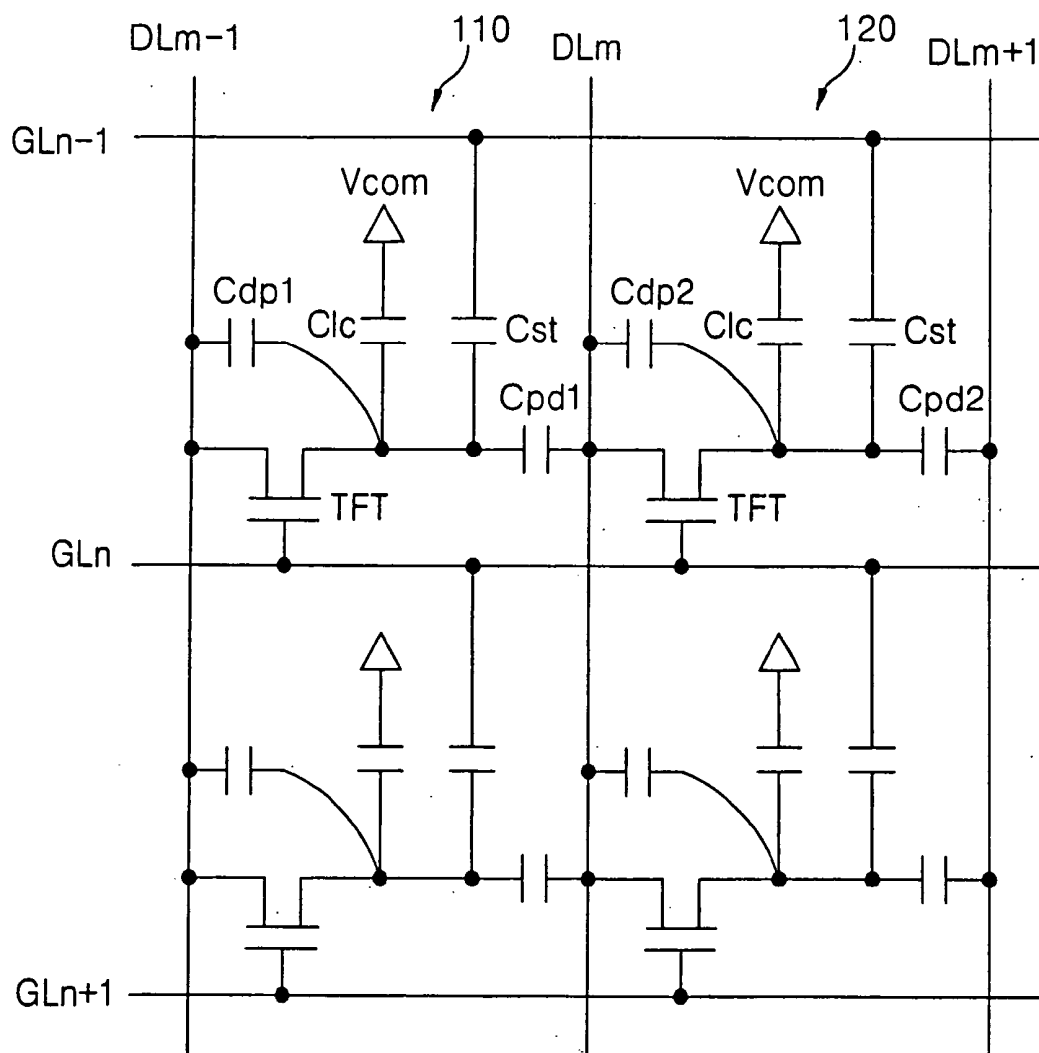



FIG. 9

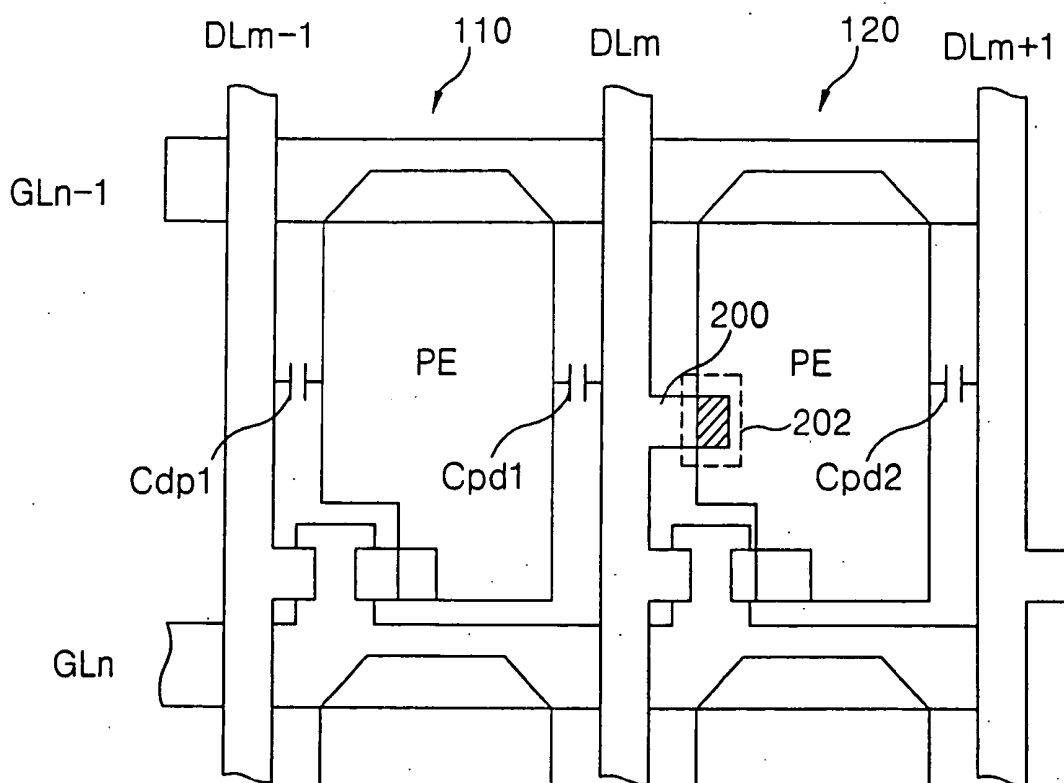
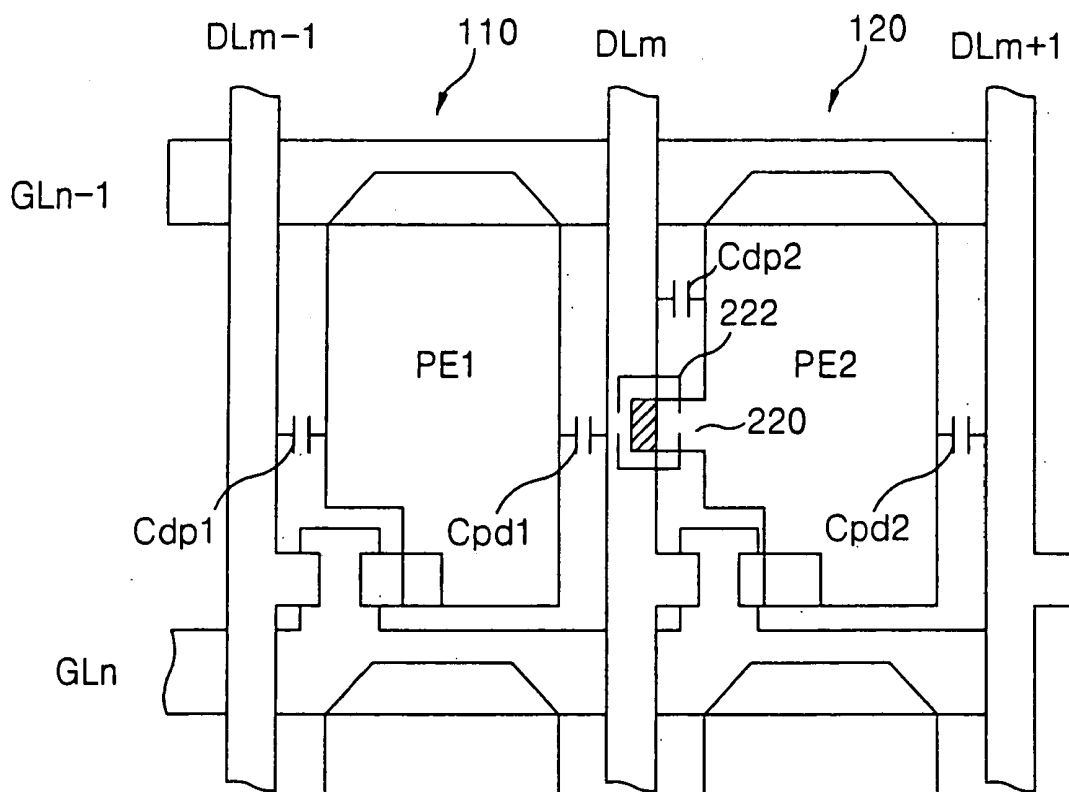

FIG. 10



## LIQUID CRYSTAL DISPLAY DEVICE

[0001] This is a Divisional Application of U.S. patent application Ser. No. 10/811,141, filed on Mar. 29, 2004; which claims priority of Korean Patent Application No. P2003-19532, filed on Mar. 28, 2003, all of which are incorporated herein by reference in their entirety.

### BACKGROUND OF THE INVENTION

[0002] 1. Field of the Invention

[0003] This invention relates to a liquid crystal display, and more particularly to a liquid crystal display that is adapted to eliminate a vertical dimming phenomenon to improve a picture quality of a liquid crystal display panel.

[0004] 2. Description of the Related Art

[0005] Generally, a liquid crystal display (LCD) controls the light transmittance of a liquid crystal using an electric field to thereby display a picture. To achieve this, the LCD includes a liquid crystal display panel having liquid crystal cells arranged in a matrix, and a driving circuit for driving the liquid crystal display panel. In the liquid crystal display panel, gate lines and data lines cross each other and liquid crystal cells are provided at areas defined by such crossings of the gate lines with the data lines. The liquid crystal display panel is provided with transparent pixel electrodes and a common electrode for applying an electric field to the liquid crystal cells. Each pixel electrode is connected, via source and drain terminals of a thin film transistor (TFT) as a switching device, to any one of the data lines. The gate terminal of the TFT is connected to any one of the gate lines. Accordingly, the LCD controls the light transmittance by an electric field applied between the pixel electrode and the common electrode in response to a data voltage signal supplied for each liquid crystal cell, to display a picture.

[0006] Such an LCD uses inversion driving schemes, such as a frame inversion system, a line (or column) inversion system and a dot inversion system, in order to drive the liquid crystal cells in the liquid crystal display panel. The frame inversion system inverts the polarities of data signals applied to the liquid crystal cells in the liquid crystal display panel whenever a frame is changed. The line inversion system inverts the polarities of data signals applied to the liquid crystal cells in accordance with the lines (or columns) on the liquid crystal display panel. The dot inversion system allows data signals having polarities contrary to that of the data signals applied to the liquid crystal cells adjacent to each other in the vertical and horizontal directions to be applied to the liquid crystal cells in the liquid crystal display panel, and allows the polarities of data signals applied to all the liquid crystal cells in the liquid crystal display panel to be inverted every frame. The dot inversion system of such inversion driving schemes provides a picture having a better picture quality than that of the frame and line inversion systems.

[0007] Typically, such an LCD is driven with a frame frequency of 60 Hz. However, a system requiring low power consumption such as a notebook personal computer requires lowering the frame frequency from 50 to 30 Hz. Since the dot inversion system capable of providing an excellent picture quality described with reference to the above-mentioned inversion systems also generates a flicker as the frame frequency decreases a liquid crystal display panel driving method having a horizontal 2-dot inversion system as shown in FIG. 1A and FIG. 1B.

[0008] Referring to FIG. 1A and FIG. 1B, there are shown data polarity patterns applied to the liquid crystal cells in the liquid crystal display panel by the liquid crystal display panel driving method employing the horizontal 2-dot inversion system, which are divided into odd frames and even frames, respectively. With respect to the odd frames shown in FIG. 1A and the even frames shown in FIG. 1B, the data polarity pattern in the horizontal 2-dot inversion driving system is changed for each two liquid crystal cells, that is, for each two dots in the horizontal direction while being changed for each one dot in the vertical direction.

[0009] If such a horizontal 2-dot inversion system is used, then a phenomenon that DC voltage concentrates on the data line from almost a majority of the screen is eliminated because an identical period between colors of red (R), green (G) and blue (B) pixels and data polarity patterns becomes 12 dots in the horizontal direction, thereby reducing a flicker. However, a use of the horizontal 2-dot inversion system causes a brightness difference between odd-numbered lines and even-numbered lines of the data lines from the gray field, thereby generating a vertical dimming phenomenon.

[0010] The above-mentioned vertical dim caused by the horizontal 2-dot inversion driving is generated by a parasitic capacitance between the data line and the pixel electrode. This will be described in detail in conjunction with FIG. 2 below.

[0011] Referring to FIG. 2 and FIG. 3, a liquid crystal cell of the conventional LCD includes thin film transistors TFT provided at crossings between data lines DL and gate lines GL, and pixel electrodes PE connected to common electrodes Vcom and the thin film transistors TFT opposed to each other with having a liquid crystal therebetween.

[0012] The thin film transistor TFT has a gate electrode connected to the gate line GL, a source electrode connected to the data line DL and a drain electrode connected to the pixel electrode PE. The thin film transistor TFT is turned on when a scanning signal, that is, a gate high voltage Vgh from the gate line GL, is applied, to thereby supply the liquid crystal cell with a pixel signal from the data line DL. Further, the thin film transistor TFT is turned off when a gate low voltage Vgl from the gate line GL is applied, to thereby maintain a pixel signal charged in the liquid crystal cell.

[0013] The liquid crystal cell further includes a storage capacitor Cst in order to maintain the charged pixel electrode PE until the next pixel signal is charged. This storage capacitor Cst is provided between the pixel electrode PE and the pre-stage gate line GLn-1. Such a liquid crystal cell varies an alignment state of a liquid crystal cell in response to a pixel signal charged via the thin film transistor TFT for the purpose of controlling a light transmittance, thereby implementing a gray level.

[0014] As shown in FIG. 3, the liquid crystal cell can be equivalently expressed as a liquid crystal capacitor Clc, which generates a parasitic capacitance because it is adjacent to the data line DL and the pixel electrode PE. In this case, the parasitic capacitance includes a first parasitic capacitance Cdp between the left data line DLm-1 and the pixel electrode PE, and a second parasitic capacitance Cpd between the pixel electrode PE and the left data line DLm. Each of the first and second parasitic capacitance Cdp and Cpd causes a voltage variation in the data line and a capacitance coupling after a pixel signal is charged in the liquid crystal cell, thereby varying a voltage of the liquid crystal cell.

**[0015]** In other words, if the liquid crystal cell is driven by the horizontal 2-dot inversion system, then two pixels having the same data polarity pattern of the data signal differ by an average variation value  $\Delta V_{p-dp}$  of a pixel voltage A caused by a capacitance coupling of the first parasitic capacitance  $C_{dp}$  from an average variation value  $\Delta V_{p-pd}$  of a pixel voltage B caused by a capacitance coupling of the second parasitic capacitance  $C_{pd}$ , as shown in FIG. 4, with respect to a left pixel 10 and a light pixel 20.

**[0016]** In this case, an average variation value  $\Delta V_{p-dp}$  of a pixel voltage A caused by a capacitance coupling of the first parasitic capacitance  $C_{dp}$  or an average variation value  $\Delta V_{p-pd}$  of a pixel voltage B caused by a capacitance coupling of the second parasitic capacitance  $C_{pd}$  can be expressed by the following equation:

$$\Delta V_{p-dp} = \frac{C_{dp} \times \Delta V(DL_m - 1) + C_{pd} \times \Delta V(DL_m)}{C_{total}} \quad (1)$$

**[0017]** wherein  $C_{total}$  represents total capacitance of the pixel electrode PE.

**[0018]** Accordingly, at the right pixel 20, the values are cancelled with respect to each other like the dot inversion driving system. On the other hand, at the left pixel 10, an average variation value  $\Delta V_{p-dp}$  of a pixel voltage A caused by a capacitance coupling of the first parasitic capacitance  $C_{dp}$  is added to an average variation value  $\Delta V_{p-pd}$  of a pixel voltage B caused by a capacitance coupling of the second parasitic capacitance  $C_{pd}$  at the left pixel 10 without being cancelled. Thus, average variation values of the pixel voltages caused by the capacitance couplings at the left pixel 10 and at the light pixel 20 become different from each other.

**[0019]** Consequently, when the first parasitic capacitance  $C_{dp}$  is equal to the second parasitic capacitance  $C_{pd}$ , an effective value of the pixel voltage at the left pixel 10 becomes two times of  $\Delta V_{p-dp}$  in comparison with that at the light pixel 20. In this case, an effective value variation in the pixel voltage increases when the pixel voltage has a positive level, whereas an effective value variation in the pixel voltage decreases when the pixel voltage has a negative level. Accordingly, there occurs a phenomenon that the right pixel 20 becomes brighter than the left pixel 10 as shown in FIG. 5. As a result, the LCD employing the horizontal 2-dot inversion driving system generates a vertical dim (or vertical line) from the liquid crystal display panel.

#### SUMMARY OF THE INVENTION

**[0020]** Accordingly, the present invention is directed to a liquid crystal display device that substantially obviates one or more of the problems due to limitations and disadvantages of the related art.

**[0021]** It is an advantage of the present invention to provide a liquid crystal display that is adaptive for eliminating a vertical dim phenomenon to improve a picture quality of a liquid crystal display panel.

**[0022]** In order to achieve these and other advantages of the invention, a liquid crystal display device according to an embodiment of the present invention includes first and second data lines supplied with data; a first pixel electrode spaced at a desired distance from the first data line; and a second pixel electrode spaced, by a distance different from said distance between the first data line and the first pixel electrode, from the second data line.

**[0023]** In the liquid crystal display device, the second pixel electrode has a larger dimension than the first pixel electrode.

**[0024]** The first and second pixel electrodes are supplied with data having the same polarity.

**[0025]** Said data have data polarity patterns inverted for each two pixel electrodes in the horizontal direction while having data polarity patterns inverted for each one pixel electrode in the vertical direction.

**[0026]** Herein, a parasitic capacitance between the second pixel electrode and the second data line has at least three times larger value than a parasitic capacitance between the first pixel electrode and the first data line.

**[0027]** A liquid crystal display device according to another embodiment of the present invention includes a first data line supplied with data; and a second data line supplied with said data and having a different width from the first data line.

**[0028]** The liquid crystal display device further includes a first pixel electrode spaced at a desired distance from the first data line; and a second pixel electrode spaced at a desired distance from the second data line.

**[0029]** In the liquid crystal display device, the first pixel electrode has the same dimension as the second pixel electrode.

**[0030]** The first and second pixel electrodes are supplied with data having the same polarity.

**[0031]** Said data have data polarity patterns inverted for each two pixel electrodes in the horizontal direction while having data polarity patterns inverted for each one pixel electrode in the vertical direction.

**[0032]** Herein, a parasitic capacitance between the second pixel electrode and the second data line has at least three times larger value than a parasitic capacitance between the first pixel electrode and the first data line.

**[0033]** A liquid crystal display device according to still another embodiment of the present invention includes a first data line supplied with data; a second data line supplied with said data and being in parallel to the first data line; and a protrusion electrode protruded from the second data line.

**[0034]** The liquid crystal display device further includes a first pixel electrode spaced at a desired distance from the first data line; and a second pixel electrode spaced at a desired distance from the second data line and overlapped with the protrusion electrode at a portion thereof.

**[0035]** In the liquid crystal display device, the first pixel electrode has the same dimension as the second pixel electrode.

**[0036]** The first and second pixel electrodes are supplied with data having the same polarity.

**[0037]** Said data have data polarity patterns inverted for each two pixel electrodes in the horizontal direction while having data polarity patterns inverted for each one pixel electrode in the vertical direction.

**[0038]** Herein, a parasitic capacitance between the second pixel electrode and the second data line and a parasitic capacitance between the protrusion electrode and the second pixel electrode have at least three times larger value than a parasitic capacitance between the first pixel electrode and the first data line.

**[0039]** A liquid crystal display device according to still another embodiment of the present invention includes first and second data lines supplied with data; a first pixel electrode spaced at a desired distance from the first data line; a second pixel electrode spaced at a desired distance from the second data line; and a protrusion electrode protruded from the second pixel electrode into the second data line and overlapped at a portion thereof.

[0040] In the liquid crystal display device, the first pixel electrode has the same dimension as the second pixel electrode.

[0041] The first and second pixel electrodes are supplied with data having the same polarity.

[0042] Said data have data polarity patterns inverted for each two pixel electrodes in the horizontal direction while having data polarity patterns inverted for each one pixel electrode in the vertical direction.

[0043] Herein, a parasitic capacitance between the second pixel electrode and the second data line and a parasitic capacitance between the protrusion electrode and the second pixel electrode have at least three times larger value than a parasitic capacitance between the first pixel electrode and the first data line.

[0044] It is to be understood that both the foregoing general description and the following detailed description are exemplary and explanatory and are intended to provide further explanation of the invention as claimed.

#### BRIEF DESCRIPTION OF THE DRAWINGS

[0045] The accompanying drawings, which are included to provide a further understanding of the invention and are incorporated in and constitute a part of this specification, illustrate embodiments of the invention and together with the description serve to explain the principles of the invention.

[0046] In the drawings:

[0047] FIG. 1A and FIG. 1B depict data polarity patterns in a horizontal 2-dot inversion system applied to a related art liquid crystal display panel;

[0048] FIG. 2 is a schematic view illustrating a liquid crystal cell configuration of a related art liquid crystal display device;

[0049] FIG. 3 is an equivalent circuit diagram of the liquid crystal cell illustrated in FIG. 2;

[0050] FIG. 4 is a waveform diagram representing a variation in a pixel voltage caused by a parasitic capacitance of the liquid crystal cell shown in FIG. 3;

[0051] FIG. 5 depicts a vertical dim phenomenon displayed on the liquid crystal display panel by a capacitance coupling effect caused by the data line and the parasitic capacitance shown in FIG. 3;

[0052] FIG. 6 is a schematic diagram illustrating a liquid crystal cell configuration having an asymmetrical pixel electrode in a liquid crystal display device according to a first embodiment of the present invention;

[0053] FIG. 7 is an equivalent circuit diagram of the liquid crystal cell illustrated in FIG. 6;

[0054] FIG. 8 is a schematic diagram illustrating a liquid crystal cell configuration of a liquid crystal display device according to a second embodiment of the present invention;

[0055] FIG. 9 is a schematic diagram illustrating a liquid crystal cell configuration of a liquid crystal display device according to a third embodiment of the present invention; and

[0056] FIG. 10 is a schematic diagram illustrating a liquid crystal cell configuration of a liquid crystal display device according to a fourth embodiment of the present invention.

#### DETAILED DESCRIPTION OF THE ILLUSTRATED EMBODIMENT

[0057] Reference will now be made in detail to an embodiment of the present invention, example of which is illustrated in the accompanying drawings.

[0058] Referring to FIG. 6 and FIG. 7, a liquid crystal cell of a liquid crystal display (LCD) according to a first embodiment of the present invention includes thin film transistors TFT provided at crossings between data lines DL and gate lines GL, and transparent pixel electrodes PE provided between adjacent data lines DL in such a manner to have a different distance from the data lines DL. The liquid crystal cell further includes a storage capacitor Cst in order to make a stable maintenance of the charged pixel electrode PE until the next pixel signal is charged.

[0059] The thin film transistor TFT has a gate electrode connected to the gate line GL, a source electrode connected to the data line DL and a drain electrode connected to the pixel electrode PE. The thin film transistor TFT is turned on when a scanning signal, that is, a gate high voltage Vgh from the gate line GL is applied, to thereby supply the liquid crystal cell with a pixel signal from the data line DL. Further, the thin film transistor TFT is turned off when a gate low voltage Vgl from the gate line GL is applied, to thereby maintain a pixel signal charged in the liquid crystal cell.

[0060] The pixel electrode PE is connected to a common electrode Vcom and the thin film transistor TFT that are opposed to each other with having a liquid crystal therebetween. Such a pixel electrode PE is comprised of a first pixel electrode PE1 spaced at a desired distance from the (m-1)th data line DLm-1, and a second pixel electrode PE2 spaced, by a distance different from the distance between the (m-1)th data line DLm-1 and the first pixel electrode PE1, from the mth data line DLm.

[0061] The first and second pixel electrodes PE1 and PE2 have a different size (or area) from each other. Herein, the second pixel electrode PE2 has a larger area than the first pixel electrode PE1.

[0062] The first pixel electrode PE1 is provided between the (m-1)th data line DLm-1 and the mth data line DLm such that a distance between one side thereof and the (m-1)th data line DLm-1 is equal to a distance between other opposite side thereof and the mth data line DLm. In this case, a parasitic capacitance is generated between the data line DL and the pixel electrode PE because they are structurally adjacent to each other. Such a parasitic capacitance causes a voltage variation in the data line and a capacitance coupling after a pixel signal was charged in the liquid crystal cell, thereby varying a pixel voltage of the liquid crystal cell. The parasitic capacitance is divided into a first parasitic capacitance Cdp1 generated between the (m-1)th data line and the first pixel electrode PE1 and a second parasitic capacitance Cpd1 generated between the first pixel electrode PE1 and the mth data line DLm.

[0063] The second pixel electrode PE2 is provided between the mth data line DLm and the (m+1)th data line DLm+1 such that a distance between one side thereof and the mth data line DLm is equal to a distance between other opposite side thereof and the (m+1)th data line DLm+1. In other words, one side of the second pixel electrode PE2 adjacent to the mth data line DLm is further extended into the mth data line DLm. In this case, a third parasitic capacitance Cdp2 is generated between the mth data line DLm and the second pixel electrode PE2 while a fourth parasitic capacitance Cpd2 is generated between the second pixel electrode PE2 and the (m+1)th data line DLm+1. Thus, the third parasitic capacitance Cdp2 is at least three times larger than the first parasitic capacitance Cdp1 of the first pixel electrode PE1. In other words, a distance W2 between one side of the second pixel electrode PE2

and the  $m$ th data line  $DL_m$  becomes narrower than a width  $W1$  between one side of the first pixel electrode  $PE1$  and the  $(m-1)$ th data line  $DL_{m-1}$ . Thus, the third parasitic capacitance  $Cdp2$  is at least three times larger than the first parasitic capacitance  $Cdp1$ . On the other hand, the fourth parasitic capacitance  $Cpd2$  has the same value as the first parasitic capacitance  $Cdp1$ .

[0064] The liquid crystal cell provided with the first and second pixel electrodes  $PE1$  and  $PE2$  is supplied with a data polarity pattern in the horizontal 2-dot inversion driving system that is changed every two liquid crystal cells, i.e., for each two dots in the horizontal direction while being changed for each one dot in the vertical direction. Accordingly, the first pixel electrode  $PE1$  and the second pixel electrode  $PE2$  are supplied with the same data polarity pattern.

[0065] As described above, when the liquid crystal cell is driven by the horizontal 2-dot inversion system, the LCD according to the first embodiment of the present invention allows the third parasitic capacitance  $Cdp2$  at a right pixel **120**, of two pixels having the same data polarity pattern, to be three times greater than the first parasitic capacitance  $Cdp1$ . Accordingly, at a left pixel **110**, an effect caused by a capacitance coupling of the first parasitic capacitance  $Cdp1$  is added to an effect caused by a capacitance coupling of the second parasitic capacitance  $Cpd1$ . On the other hand, at the right pixel **120**, an effect caused by a capacitance coupling of the fourth parasitic capacitance  $Cpd2$  is subtracted from an effect caused by a capacitance coupling of the third parasitic capacitance  $Cdp2$ , but an effect caused by the same capacitance coupling as the left pixel **110** only is left because an effect caused by a capacitance coupling of the third parasitic capacitance  $Cdp2$  is relatively large. Thus, a deviation in the pixel voltage of the left pixel **110** and the right pixel **120** in the data polarity pattern is cancelled. Accordingly, the LCD according to the embodiment of the present invention does not generate a vertical dimming phenomenon caused by the parasitic capacitance between the data line and the pixel electrode in the related art.

[0066] Referring to FIG. 8, a liquid crystal cell of a liquid crystal display (LCD) according to a second embodiment of the present invention includes thin film transistors TFT provided at crossings between data lines  $DL$  and gate lines  $GL$  having a different widths, and pixel electrodes  $PE$  connected to the thin film transistor TFT. The liquid crystal cell further includes a storage capacitor  $Cst$  in order to maintain the charged pixel electrode  $PE$  until the next pixel signal is charged.

[0067] The thin film transistor TFT has a gate electrode connected to the gate line  $GL$ , a source electrode connected to the data line  $DL$  and a drain electrode connected to the pixel electrode  $PE$ . The thin film transistor TFT is turned on when a scanning signal, that is, a gate high voltage  $V_{gh}$  from the gate line  $GL$  is applied, to thereby supply the liquid crystal cell with a pixel signal from the data line  $DL$ . Further, the thin film transistor TFT is turned off when a gate low voltage  $V_{gl}$  from the gate line  $GL$  is applied, to thereby maintain a pixel signal charge in the liquid crystal cell.

[0068] The data lines  $DL$  includes a first data line  $DL_{m-1}$  having a first width  $W1$ , and a second data line  $DL_m$  having a second width  $W2$  larger than the first width  $W1$  and provided in parallel to the first data line  $DL_{m-1}$ . The first and second data lines  $DL_{m-1}$  and  $DL_m$  are repeatedly provided to have the same distance.

[0069] The pixel electrode  $PE$  is provided between the data lines  $DL$  and connected to the thin film transistor TFT.

[0070] At a left pixel **110** provided at the left side around the second data line  $DL_m$  in the liquid crystal cell, a first parasitic capacitance  $Cdp1$  is generated between the first data line  $DL_{m-1}$  and the pixel electrode  $PE$  while a second parasitic capacitance  $Cpd1$  is generated between the pixel electrode  $PE$  and the second data line  $DL_m$ . On the other hand, at a right pixel **120** provided at the right side of the second data line  $DL_m$  in the liquid crystal cell, a third parasitic capacitance  $Cdp2$  is generated between the second data line  $DL_m$  and the pixel electrode  $PE$  while a fourth parasitic capacitance  $Cpd2$  is generated between the pixel electrode  $PE$  and the first data line  $DL_{m+1}$ .

[0071] Thus, the third parasitic capacitance  $Cdp2$  of the right pixel **120** is at least three times greater than the first parasitic capacitance  $Cdp1$  of the left pixel **110**. To this end, a width  $W2$  of the second data line  $DL_m$  is set to be larger than a width  $W1$  of the first data line  $DL_{m-1}$  within a width range of a black matrix (not shown). Thus, the third parasitic capacitance  $Cdp2$  is at least three times greater than the first parasitic capacitance  $Cdp1$  because a distance between the second data line  $DL_m$  and the pixel electrode  $PE$  is shorter than a distance between the first data line  $DL_{m-1}$  and the pixel electrode  $PE$ .

[0072] As described above, when the liquid crystal cell is driven by the horizontal 2-dot inversion system, the LCD according to the second embodiment of the present invention allows the third parasitic capacitance  $Cdp2$  at a right pixel **120** of two pixels having the same data polarity pattern to be three times greater than the first parasitic capacitance  $Cdp1$ . Accordingly, at a left pixel **110**, an effect caused by a capacitance coupling of the first parasitic capacitance  $Cdp1$  is added to an effect caused by a capacitance coupling of the second parasitic capacitance  $Cpd1$ . On the other hand, at the right pixel **120**, an effect caused by a capacitance coupling of the fourth parasitic capacitance  $Cpd2$  is subtracted from an effect caused by a capacitance coupling of the third parasitic capacitance  $Cdp2$ , but an effect caused by the same capacitance coupling as the left pixel **110** only is left because an effect caused by a capacitance coupling of the third parasitic capacitance  $Cdp2$  is relatively large. Thus, a deviation in the pixel voltage of the left pixel **110** and the right pixel **120** in the data polarity pattern is cancelled. Accordingly, the LCD according to the embodiment of the present invention does not generate a vertical dimming phenomenon caused by the parasitic capacitance between the data line and the pixel electrode in the related art.

[0073] Referring to FIG. 9, a liquid crystal cell of a liquid crystal display (LCD) according to a third embodiment of the present invention includes thin film transistors TFT provided at crossings of data lines  $DL$  and gate lines  $GL$  having a different width from each other, and pixel electrodes  $PE$  connected to the thin film transistor TFT. The liquid crystal cell further includes a storage capacitor  $Cst$  in order to make a stable maintenance of the charged pixel electrode  $PE$  until the next pixel signal is charged.

[0074] The thin film transistor TFT has a gate electrode connected to the gate line  $GL$ , a source electrode connected to the data line  $DL$  and a drain electrode connected to the pixel electrode  $PE$ . The thin film transistor TFT is turned on when a scanning signal, that is, a gate high voltage  $V_{gh}$  from the gate line  $GL$  is applied, to thereby supply the liquid crystal cell with a pixel signal from the data line  $DL$ . Further, the thin film transistor TFT is turned off when a gate low voltage  $V_{gl}$

from the gate line GL is applied, to thereby maintain a pixel signal charged in the liquid crystal cell.

**[0075]** The data lines DL include a first data line DL<sub>m-1</sub>, and a second data line DL<sub>m</sub> provided substantially in parallel to the first data line DL<sub>m-1</sub> and having a protrusion electrode **200** extending from the pixel electrode PE at one side thereof and overlapping with the pixel electrode PE at a portion thereof. The first and second data lines DL<sub>m-1</sub> and DL<sub>m</sub> are repeatedly provided to have the same distance.

**[0076]** The pixel electrode PE is provided between the data lines DL and connected to the thin film transistor TFT.

**[0077]** At a left pixel **110** provided at the left side around the second data line DL<sub>m</sub> in the liquid crystal cell, a first parasitic capacitance Cdp1 is generated between the first data line DL<sub>m-1</sub> and the pixel electrode PE while a second parasitic capacitance Cpd1 is generated between the pixel electrode PE and the second data line DL<sub>m</sub>. At a right pixel **120** provided at the right side around the second data line DL<sub>m</sub> in the liquid crystal cell, a third parasitic capacitance Cdp2 is generated between the second data line DL<sub>m</sub> and the pixel electrode PE while a fourth parasitic capacitance Cpd2 is generated between the pixel electrode PE and the first data line DL<sub>m+1</sub>. Further, at the right pixel **120**, the pixel electrode PE overlaps with the protrusion electrode **200** of the second data line DL<sub>m</sub> to thereby generate an additional capacitance **202**.

**[0078]** Thus, the third parasitic capacitance Cdp2 and the additional capacitance **202** generated between the second data line DL<sub>m</sub> and the pixel electrode PE at the right pixel **120** is at least three times greater than the first parasitic capacitance Cdp1. To this end, the protrusion electrode **200** overlaps with the second data line DL<sub>m</sub> such that a sum of the additional capacitance **202** and the third capacitance Cdp2 is at least three times greater than the first capacitance Cdp1.

**[0079]** As described above, when the liquid crystal cell is driven by the horizontal 2-dot inversion system, the LCD according to the third embodiment of the present invention allows the additional capacitance **202** and the third parasitic capacitance Cdp2 at a right pixel **120**, of two pixels having the same data polarity pattern, to be three times greater than the first parasitic capacitance Cdp1. Accordingly, at a left pixel **110**, an effect caused by a capacitance coupling of the first parasitic capacitance Cdp1 is added to an effect caused by a capacitance coupling of the second parasitic capacitance Cpd1. On the other hand, at the right pixel **120**, an effect caused by a capacitance coupling of the fourth parasitic capacitance Cpd2 is subtracted from an effect caused by a capacitance coupling of the third parasitic capacitance Cdp2 and an effect caused by a capacitance coupling of the additional capacitance **202**, but an effect caused by the same capacitance coupling as the left pixel **110** only is left because an effect caused by a capacitance coupling of the third parasitic capacitance Cdp2 is relatively large. Thus, a deviation in the pixel voltage of the left pixel **110** and the right pixel **120** in the data polarity pattern is cancelled. Accordingly, the LCD according to the embodiment of the present invention does not generate a vertical dim phenomenon caused by the parasitic capacitance between the data line and the pixel electrode in the prior art.

**[0080]** Referring to FIG. 10, a liquid crystal cell of a liquid crystal display (LCD) according to a fourth embodiment of the present invention includes thin film transistors TFT provided at crossings of data lines DL and gate lines GL, and pixel electrodes PE connected to the thin film transistor TFT. The liquid crystal cell further includes a storage capacitor Cst

in order to make a stable maintenance of the charged pixel electrode PE until the next pixel signal is charged.

**[0081]** The thin film transistor TFT has a gate electrode connected to the gate line GL, a source electrode connected to the data line DL and a drain electrode connected to the pixel electrode PE. The thin film transistor TFT is turned on when a scanning signal, that is, a gate high voltage V<sub>gh</sub> from the gate line GL is applied, to thereby supply the liquid crystal cell with a pixel signal from the data line DL. Further, the thin film transistor TFT is turned off when a gate low voltage V<sub>gl</sub> from the gate line GL is applied, to thereby maintain a pixel signal charged in the liquid crystal cell.

**[0082]** The pixel electrode PE is provided between the data lines DL and connected to the thin film transistor TFT. Such a pixel electrode PE is comprised of a first pixel electrode PE1 connected to the thin film transistor TFT provided at an intersection between the (m-1)th data line DL<sub>m-1</sub> and the gate line GL, and a second pixel electrode PE2 connected to the thin film transistor TFT provided at an intersection between the mth data line DL<sub>m</sub> and the gate line GL. In this case, the first pixel electrode PE1 is arranged at the left side around the mth data line DL<sub>m</sub> while the second pixel electrode PE2 is arranged at the right side around the mth data line DL<sub>m</sub>.

**[0083]** The first pixel electrode PE1 is provided between the (m-1)th data line DL<sub>m-1</sub> and the mth data line DL<sub>m</sub> such that a distance between one side thereof and the (m-1)th data line DL<sub>m-1</sub> is equal to a distance between other opposite side thereof and the mth data line DL<sub>m</sub>. In this case, a parasitic capacitance is generated between the data line DL and the pixel electrode PE because they are adjacent to each other for a structure's sake. Such a parasitic capacitance causes a voltage variation in the data line and a capacitance coupling after a pixel signal was charged in the liquid crystal cell, thereby varying a pixel voltage of the liquid crystal cell. The parasitic capacitance is divided into a first parasitic capacitance Cdp1 generated between the (m-1)th data line and the first pixel electrode PE1 and a second parasitic capacitance Cpd1 generated between the first pixel electrode PE1 and the mth data line DL<sub>m</sub>.

**[0084]** The second pixel electrode PE2 is provided between the mth data line DL<sub>m</sub> and the (m+1)th data line DL<sub>m+1</sub> such that a distance between one side thereof and the mth data line DL<sub>m</sub> is equal to a distance between other opposite side thereof and the (m+1)th data line DL<sub>m+1</sub>. In other words, one side of the second pixel electrode PE2 adjacent to the mth data line DL<sub>m</sub> extends further into the mth data line DL<sub>m</sub>. In this case, a third parasitic capacitance Cdp2 is generated between the mth data line DL<sub>m</sub> and the second pixel electrode PE2 while a fourth parasitic capacitance Cpd2 is generated between the second pixel electrode PE2 and the (m+1)th data line DL<sub>m+1</sub>. Thus, the third parasitic capacitance Cdp2 has at least three times larger value than the first parasitic capacitance Cdp1 of the first pixel electrode PE1. In other words, a distance W2 between one side of the second pixel electrode PE2 and the mth data line DL<sub>m</sub> becomes narrower than a width W1 between one side of the first pixel electrode PE1 and the (m-1)th data line DL<sub>m-1</sub>. Thus, the third parasitic capacitance Cdp2 is at least three times greater than the first parasitic capacitance Cdp1. On the other hand, the fourth parasitic capacitance Cpd2 has the same value as the first parasitic capacitance Cdp1.

**[0085]** The liquid crystal cell provided with the first and second pixel electrodes PE1 and PE2 is supplied with a data

polarity pattern in the horizontal 2-dot inversion driving system that is changed for each two liquid crystal cells, that is, for each two dots in the horizontal direction while being changed for each one dot in the vertical direction. Accordingly, the first pixel electrode PE1 and the second pixel electrode PE2 are supplied with the same data polarity pattern.

[0086] As described above, when the liquid crystal cell is driven by the horizontal 2-dot inversion system, the LCD according to the fourth embodiment of the present invention allows the third parasitic capacitance Cdp2 at a right pixel 120, of two pixels having the same data polarity pattern, to be three times greater than the first parasitic capacitance Cdp1. Accordingly, at a left pixel 110, an effect caused by a capacitance coupling of the first parasitic capacitance Cdp1 is added to an effect caused by a capacitance coupling of the second parasitic capacitance Cpd1. On the other hand, at the right pixel 120, an effect caused by a capacitance coupling of the fourth parasitic capacitance Cpd2 is subtracted from an effect caused by a capacitance coupling of the third parasitic capacitance Cdp2, but an effect caused by the same capacitance coupling as the left pixel 110 only is left because an effect caused by a capacitance coupling of the third parasitic capacitance Cdp2 is relatively large. Thus, a deviation in the pixel voltage of the left pixel 110 and the right pixel 120 in the data polarity pattern is cancelled. Accordingly, the LCD according to the embodiment of the present invention does not generate a vertical dimming phenomenon caused by the parasitic capacitance between the data line and the pixel electrode in the prior art.

[0087] The second pixel electrode PE2 of the first and second pixel electrodes PE1 and PE2 includes a protrusion electrode 220 that extends toward the mth data line DLm at the side surface thereof to overlap with a portion thereof.

[0088] At a left pixel 110 provided at the left side around the second data line DLm in the liquid crystal cell, a first parasitic capacitance Cdp1 is generated between the (m-1)th data line DLm-1 and the first pixel electrode PE1 while a second parasitic capacitance Cpd1 is generated between the first pixel electrode PE1 and the mth data line DLm. On the other hand, at a right pixel 120 provided at the right side around the mth data line DLm in the liquid crystal cell, a third parasitic capacitance Cdp2 is generated between the mth data line DLm and the second pixel electrode PE2 while a fourth parasitic capacitance Cpd2 is generated between the second pixel electrode PE2 and the (m+1)th data line DLm+1. Further, at the right pixel 120, the second pixel electrode PE2 overlaps with the protrusion electrode 220 of the mth data line DLm to thereby generate an additional capacitance 222.

[0089] Thus, the third parasitic capacitance Cdp2 and the additional capacitance 222 generated between the mth data line DLm and the second pixel electrode PE2 at the right pixel 120 is at least three times greater than the first parasitic capacitance Cdp1. To this end, the protrusion electrode 220 overlaps with the mth data line DLm such that a sum of the additional capacitance 222 and the third parasitic capacitance Cdp2 is at least three times greater than the first capacitance Cdp1.

[0090] As described above, when the liquid crystal cell is driven by the horizontal 2-dot inversion system, the LCD according to the fourth embodiment of the present invention allows third parasitic capacitance Cdp2 at a right pixel 120 of two pixels having the same data polarity pattern to be three times greater than the first parasitic capacitance Cdp1. Accordingly, at a left pixel 110, an effect caused by a capaci-

ance coupling of the first parasitic capacitance Cdp1 is added to an effect caused by a capacitance coupling of the second parasitic capacitance Cpd1. On the other hand, at the right pixel 120, an effect caused by a capacitance coupling of the fourth parasitic capacitance Cpd2 is subtracted from an effect caused by a capacitance coupling of the third parasitic capacitance Cdp2 and an effect caused by a capacitance coupling of the additional capacitance 222, but an effect caused by the same capacitance coupling as the left pixel 110 only is left because an effect caused by a capacitance coupling of the third parasitic capacitance Cdp2 is relatively large. Thus, a deviation in the pixel voltage of the left pixel 110 and the right pixel 120 in the data polarity pattern is cancelled. Accordingly, the LCD according to the embodiment of the present invention does not generate a vertical dimming phenomenon caused by the parasitic capacitance between the data line and the pixel electrode in the prior art.

[0091] As described above, the LCD according to the present invention includes the pixel electrode set such that parasitic capacitance values between the data lines are asymmetrical to each other. Further, the LCD according to the present invention includes the data lines having a different width from each other such that parasitic capacitance values between the data lines are asymmetrical to each other. Alternatively, the LCD according to the present invention includes the pixel electrode protruded toward the data line to overlap with a portion thereof such that parasitic capacitance values between the data lines are asymmetrical to each other. Otherwise, the LCD according to the present invention includes the data line protruded toward the pixel to overlap with a portion thereof such that parasitic capacitance values between the data lines are asymmetrical to each other.

[0092] Accordingly, the LCD according to the present invention does not generate a vertical dimming phenomenon caused by the parasitic capacitance between the data line and the pixel in the horizontal 2-dot inversion system. As a result, the LCD according to the present invention can improve a picture quality of the liquid crystal display panel.

[0093] It will be apparent to those skilled in the art that various modifications and variation can be made in the present invention without departing from the spirit or scope of the invention. Thus, it is intended that the present invention cover the modifications and variations of this invention provided they come within the scope of the appended claims and their equivalents.

What is claimed is:

1. A liquid crystal display device, comprising:
  - a first data line supplied with data; and
  - a second data line supplied with said data and having a different width from the first data line.
2. The liquid crystal display device according to claim 1, further comprising:
  - a first pixel electrode spaced at a desired distance from the first data line; and
  - a second pixel electrode spaced at a desired distance from the second data line.
3. The liquid crystal display device according to claim 2, wherein the first pixel electrode has the same dimension as the second pixel electrode.
4. The liquid crystal display device according to claim 2, wherein the first and second pixel electrodes are supplied with data having the same polarity.
5. The liquid crystal display device according to claim 2, wherein said data have data polarity patterns inverted for each

two pixel electrodes in the horizontal direction while having data polarity patterns inverted for each one pixel electrode in the vertical direction.

6. The liquid crystal display device according to claim 2, wherein a parasitic capacitance between the second pixel electrode and the second data line has at least three times larger value than a parasitic capacitance between the first pixel electrode and the first data line.

7. A liquid crystal display device, comprising:

a first data line supplied with a signal;  
a second data line supplied with said signal and parallel to the first data line; and

a protrusion electrode protruding from the second data line.

8. The liquid crystal display device according to claim 7, further comprising:

a first pixel electrode spaced at a desired distance from the first data line; and

a second pixel electrode spaced at a desired distance from the second data line and overlapped with the protrusion electrode at a portion thereof.

9. The liquid crystal display device according to claim 8, wherein the first pixel electrode has the same dimension as the second pixel electrode.

10. The liquid crystal display device according to claim 8, wherein the first and second pixel electrodes are supplied with signals having the same polarity.

11. The liquid crystal display device according to claim 8, wherein said signals have polarity inverted for each two pixel electrodes in the horizontal direction while having polarity inverted for each one pixel electrode in the vertical direction.

12. The liquid crystal display device according to claim 8, wherein a parasitic capacitance between the second pixel electrode and the second data line and a parasitic capacitance between the protrusion electrode and the second pixel electrode are at least three times greater than a parasitic capacitance between the first pixel electrode and the first data line.

\* \* \* \* \*

