



US 20030151717A1

(19) **United States**

(12) **Patent Application Publication**
Shin

(10) **Pub. No.: US 2003/0151717 A1**

(43) **Pub. Date: Aug. 14, 2003**

(54) **DEVICE FOR CUTTING LIQUID CRYSTAL
DISPLAY PANEL AND METHOD FOR
CUTTING USING THE SAME**

Publication Classification

(51) **Int. Cl.⁷ G02F 1/1333**

(52) **U.S. Cl. 349/158**

(75) **Inventor: Sang-Sun Shin, Kyongsangbuk-do
(KR)**

Correspondence Address:
**MORGAN LEWIS & BOCKIUS LLP
1111 PENNSYLVANIA AVENUE NW
WASHINGTON, DC 20004 (US)**

(57) **ABSTRACT**

(73) **Assignee: LG. Philips LCD Co., Ltd.**

(21) **Appl. No.: 10/126,698**

(22) **Filed: Apr. 22, 2002**

(30) **Foreign Application Priority Data**

Feb. 9, 2002 (KR) P2002-007774

A device for cutting a liquid crystal display panel includes a first scribing unit for forming a first scribing line at first and second mother substrates by using first and second wheels and pressing at least a portion of the first scribing line with a first roll, a second scribing unit for forming a second scribing line at the first and second mother substrates by using third and fourth wheels and pressing at least a portion of the second scribing line with a second roll, and a first rotating unit for rotating the first and second mother substrates to form the second scribing line.

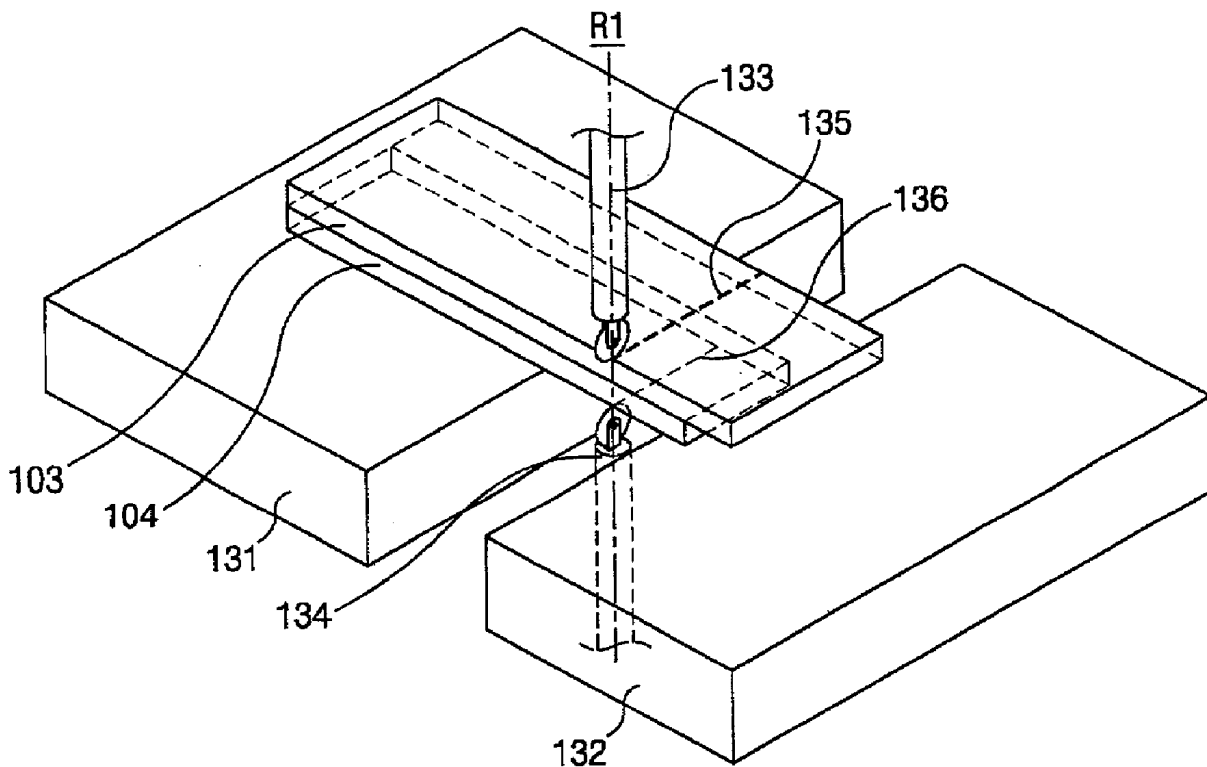

FIG. 1
BACKGROUND ART

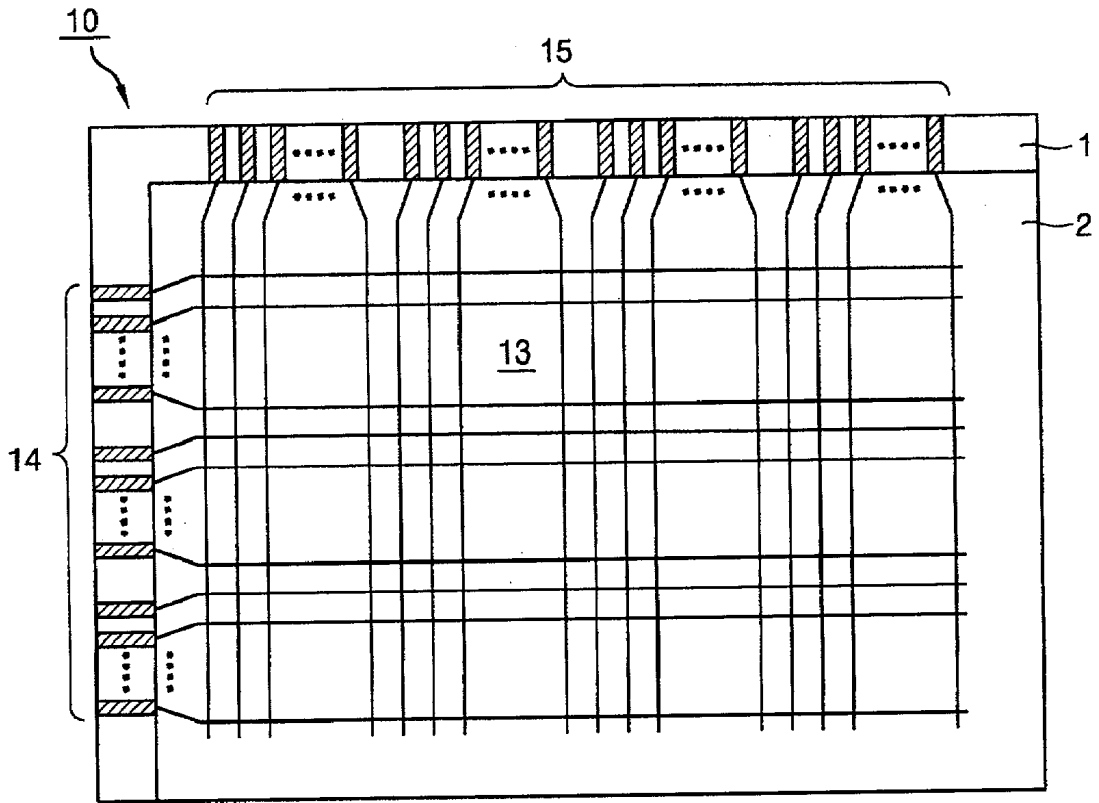

FIG. 2
BACKGROUND ART

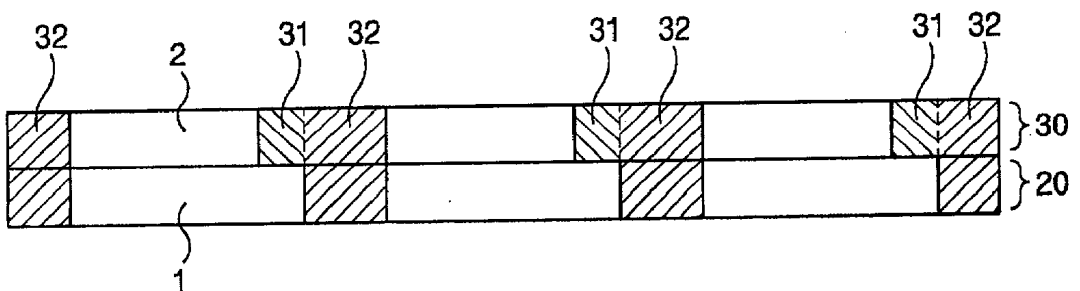

FIG. 3A
BACKGROUND ART.

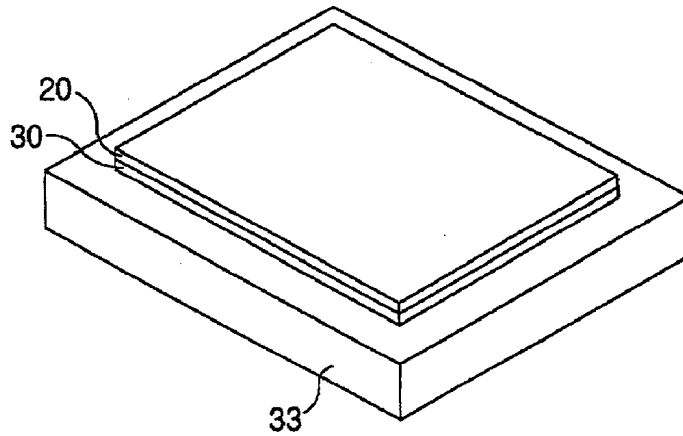

FIG. 3B
BACKGROUND ART

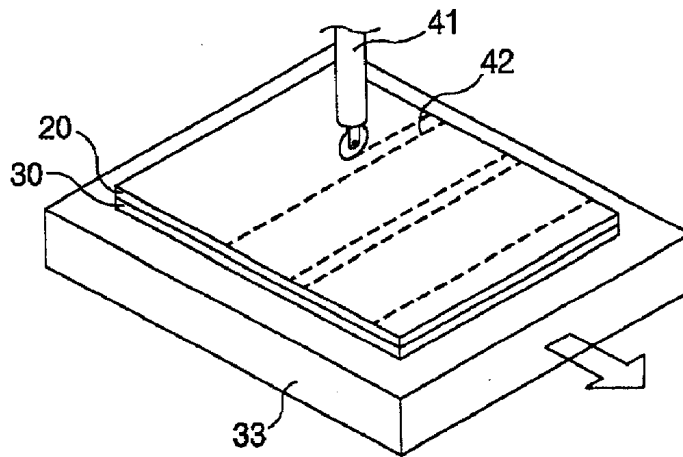

FIG. 3C
BACKGROUND ART

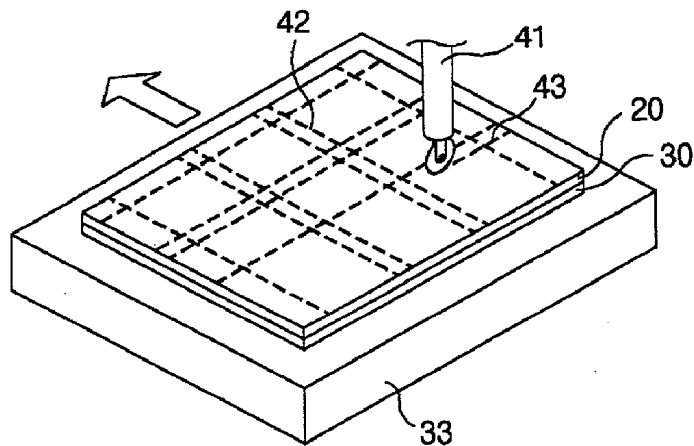

FIG. 3D
BACKGROUND ART

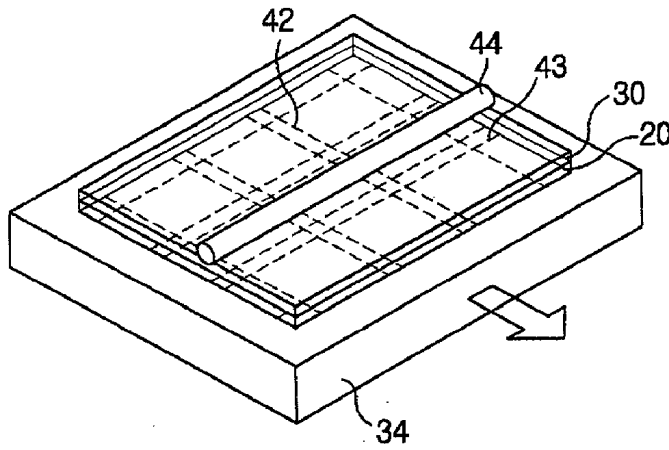

FIG. 3E
BACKGROUND ART

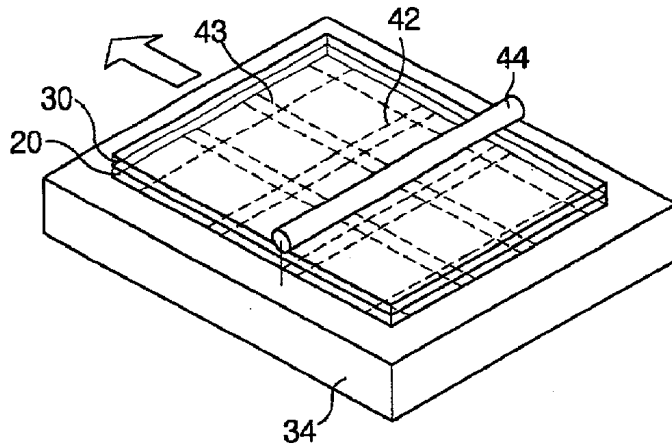

FIG. 3F
BACKGROUND ART

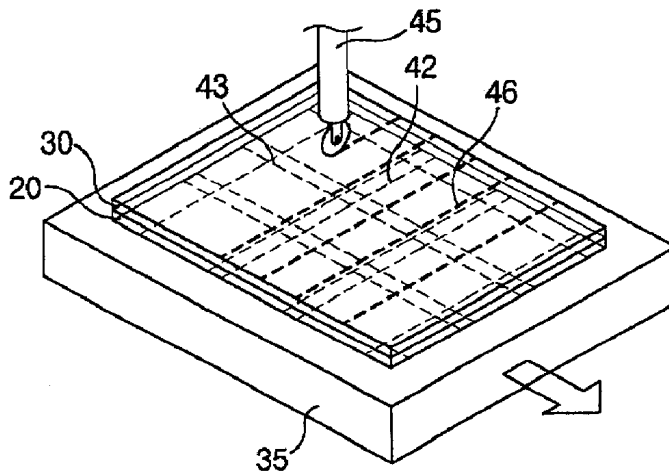

FIG. 3G
BACKGROUND ART

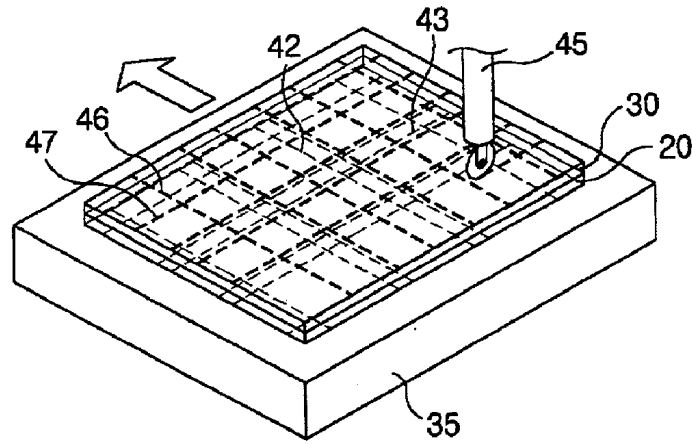

FIG. 3H
BACKGROUND ART

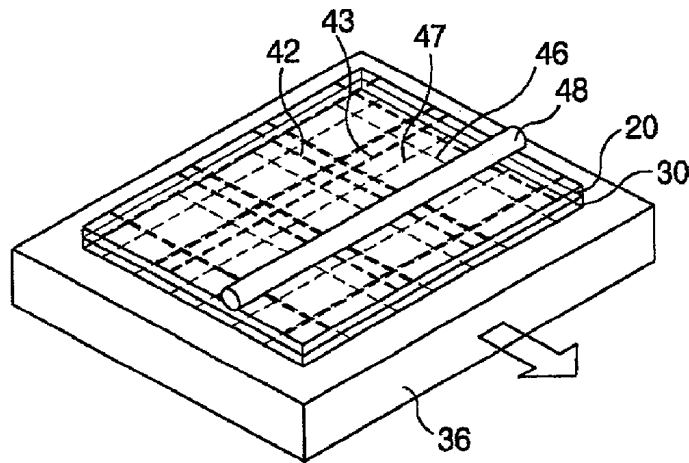

FIG. 3I
BACKGROUND ART

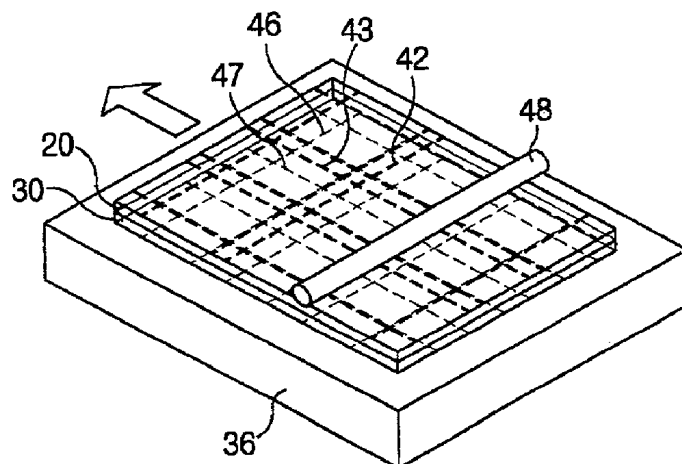

FIG. 3J
BACKGROUND ART

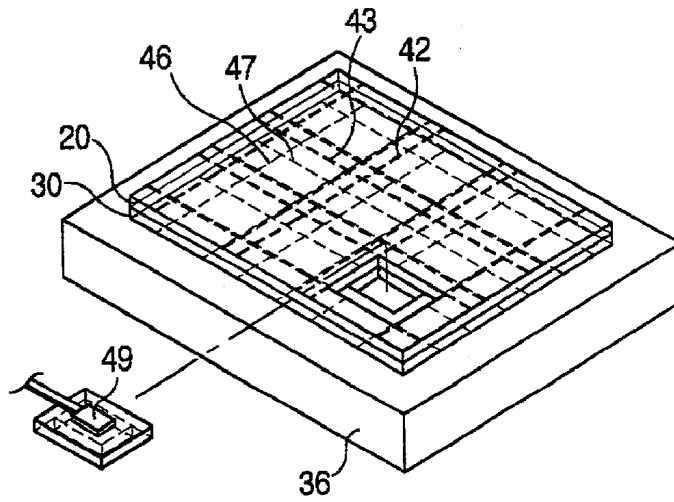

FIG. 4

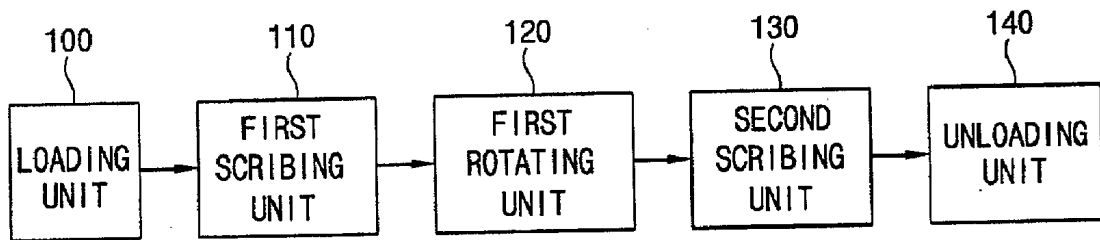

FIG. 5A

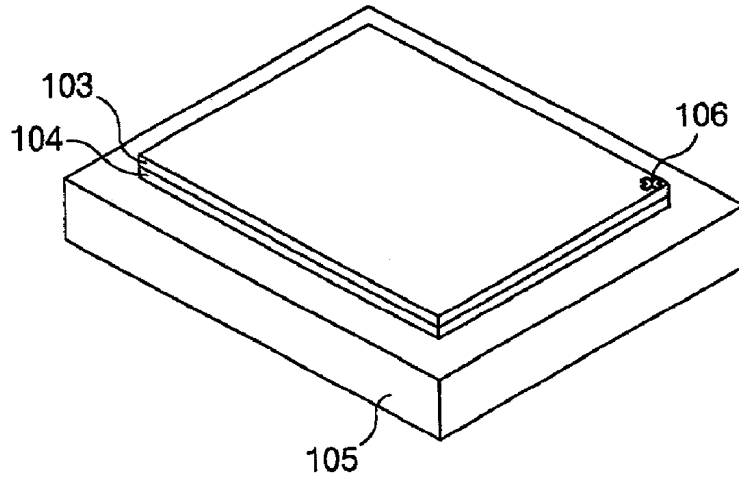

FIG. 5B

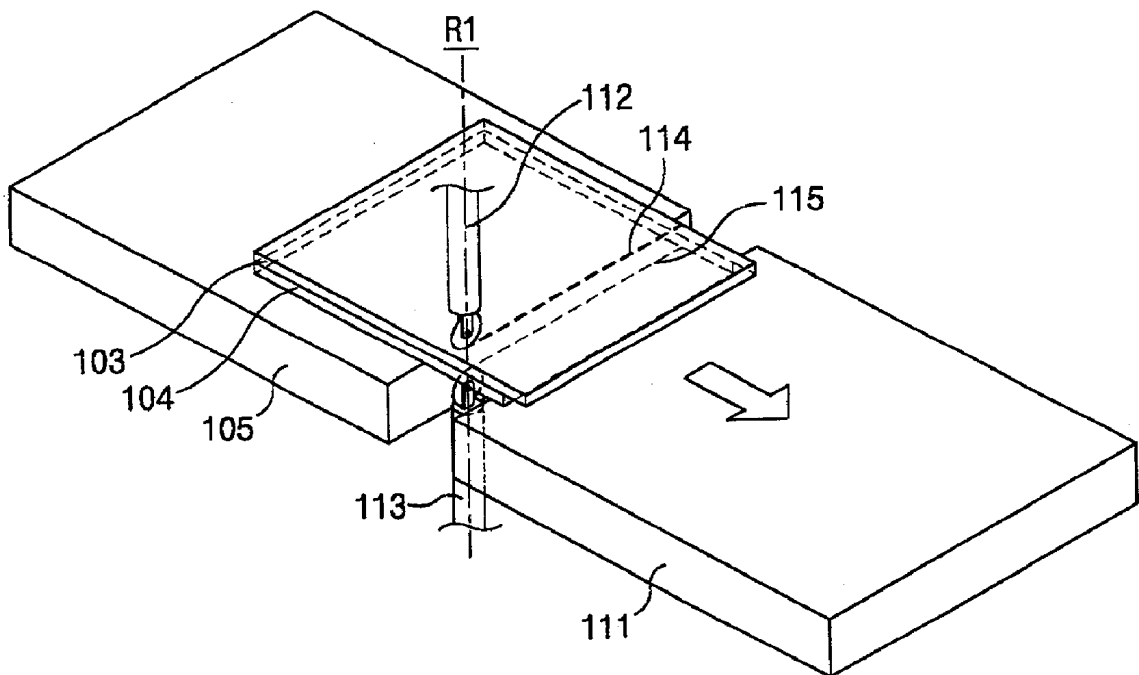

FIG. 5C

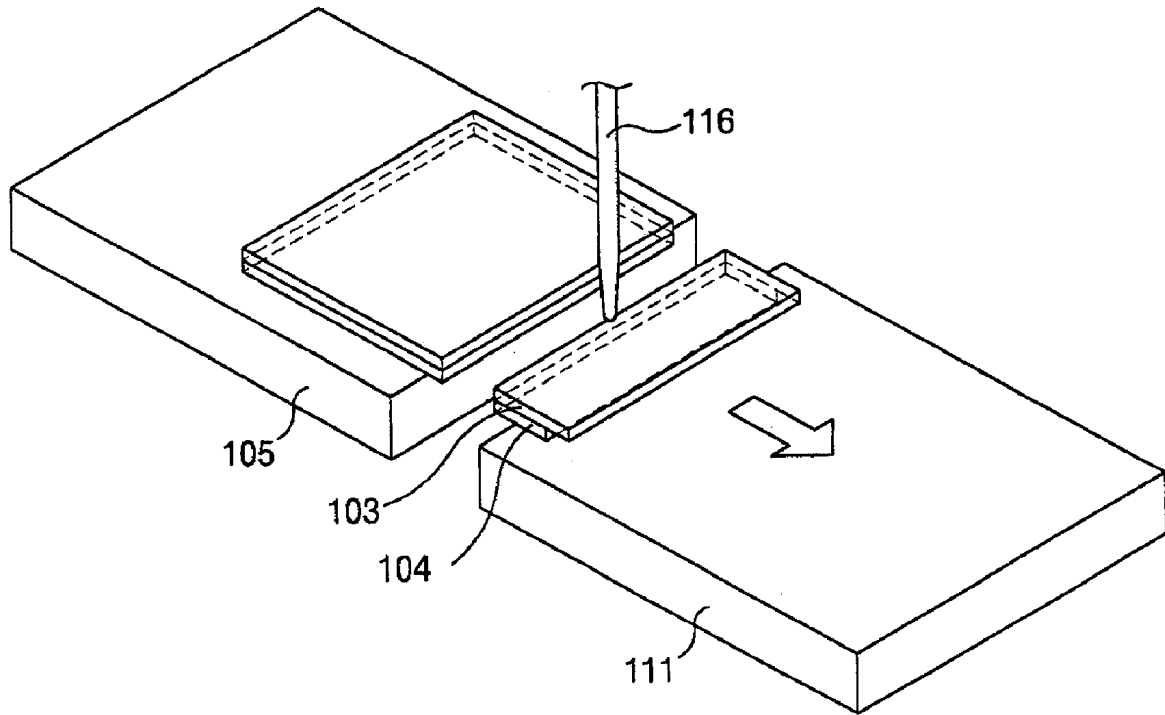

FIG. 5D

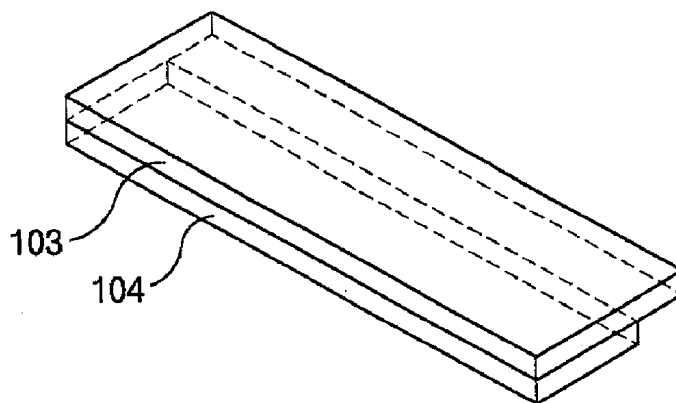

FIG. 5E

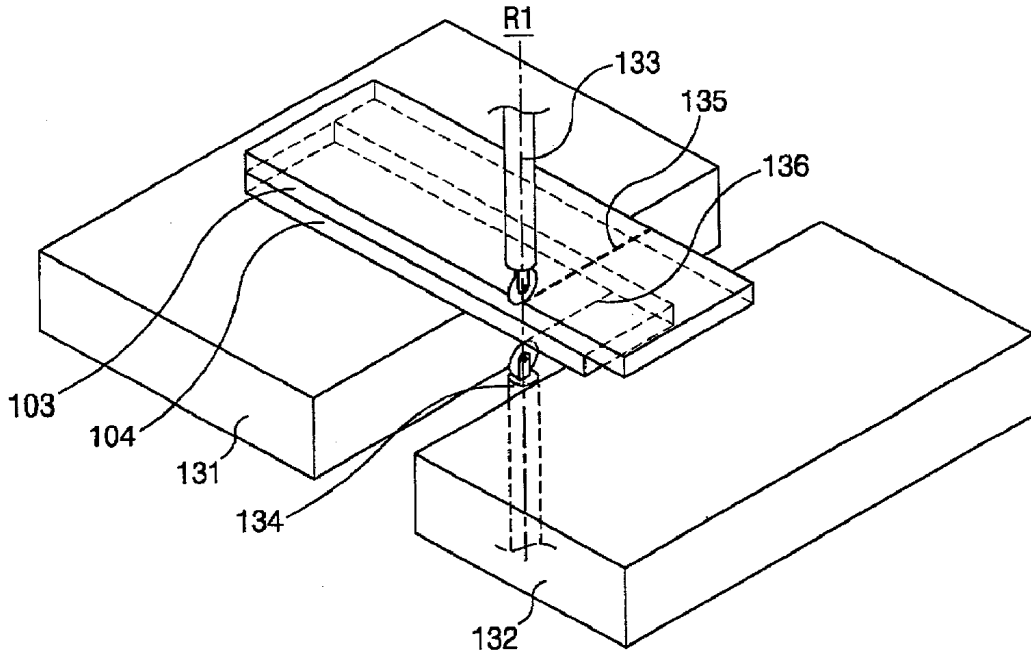

FIG. 5F

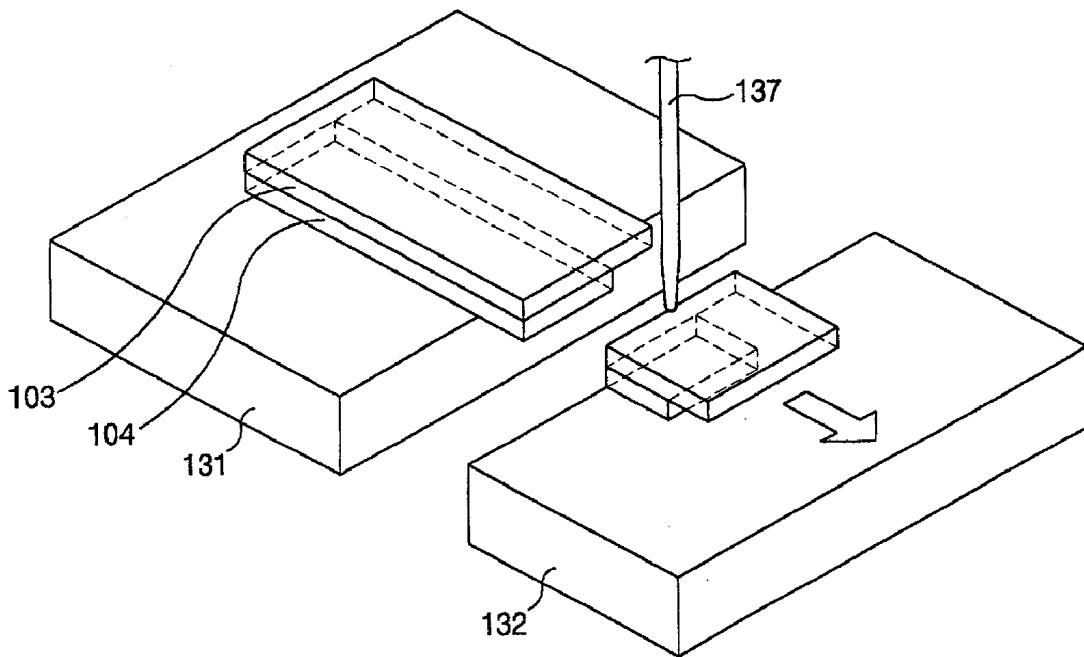

FIG. 5G

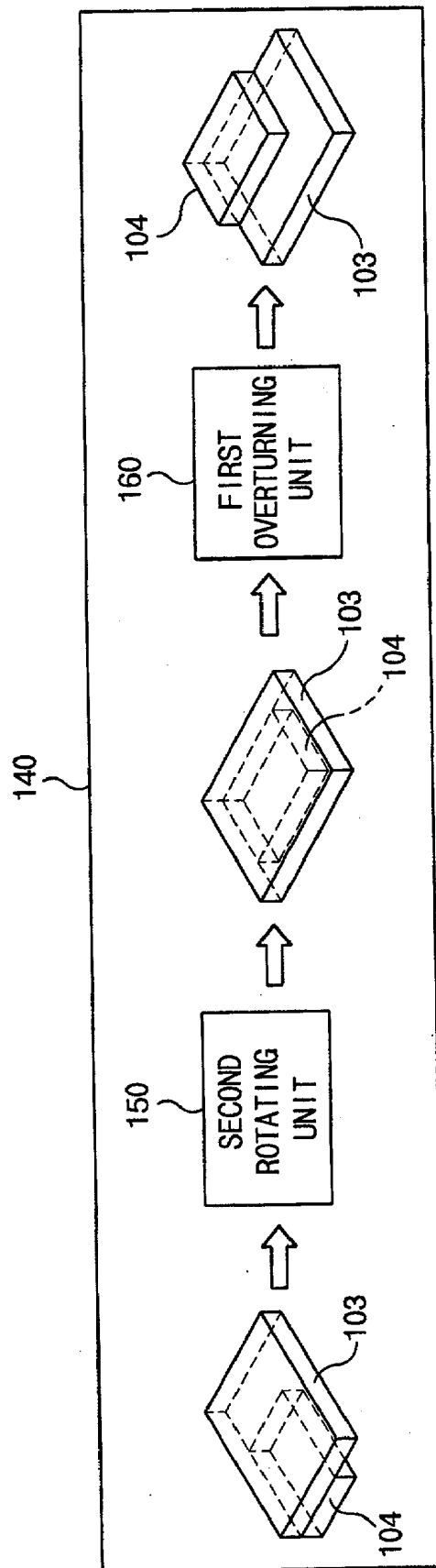

FIG. 6

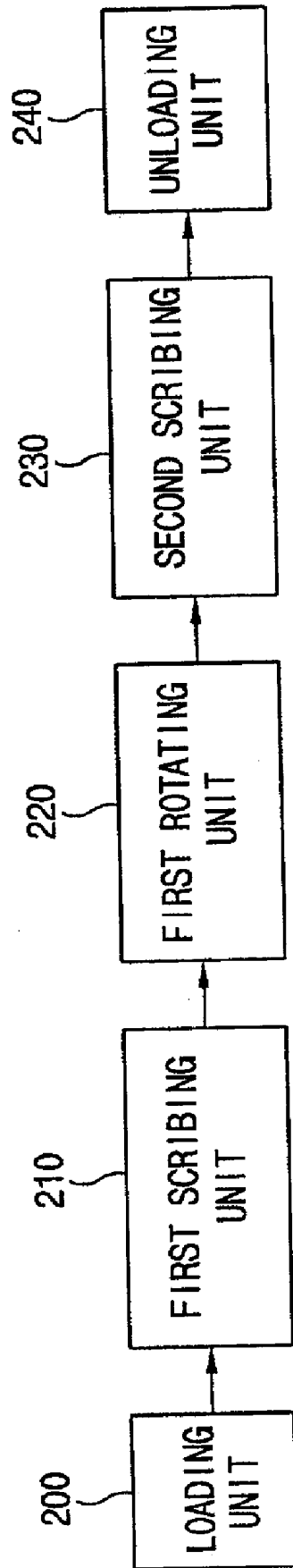

FIG. 7C

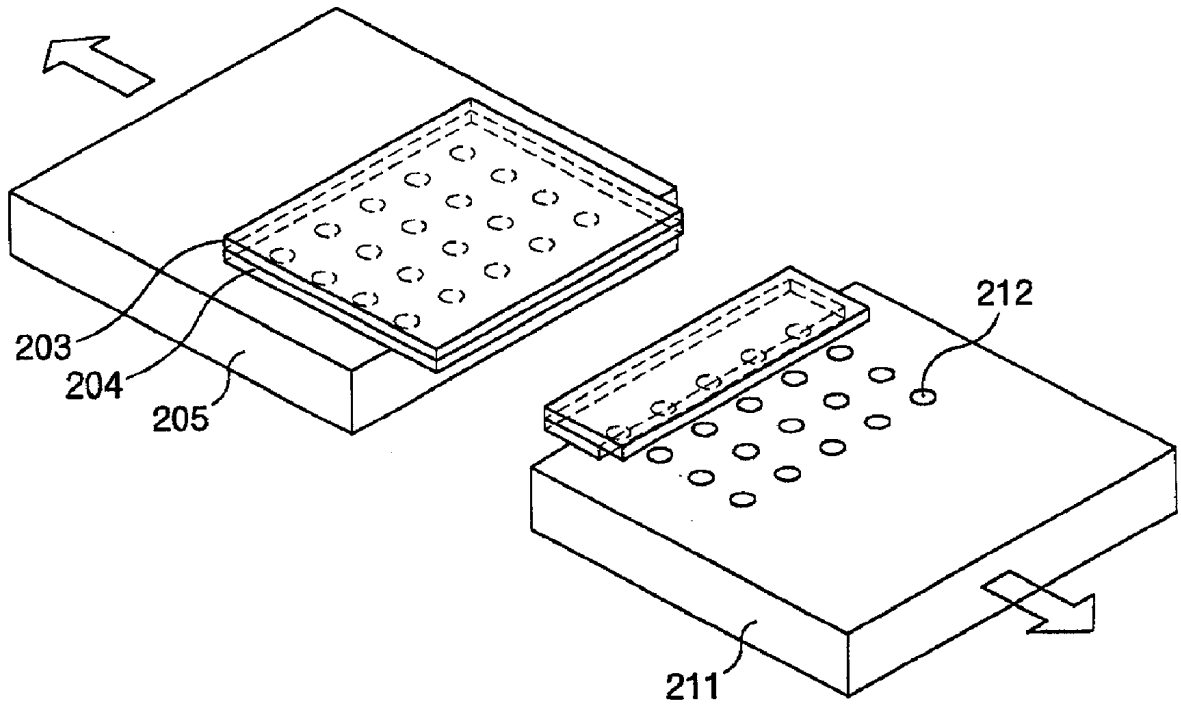

FIG. 7D

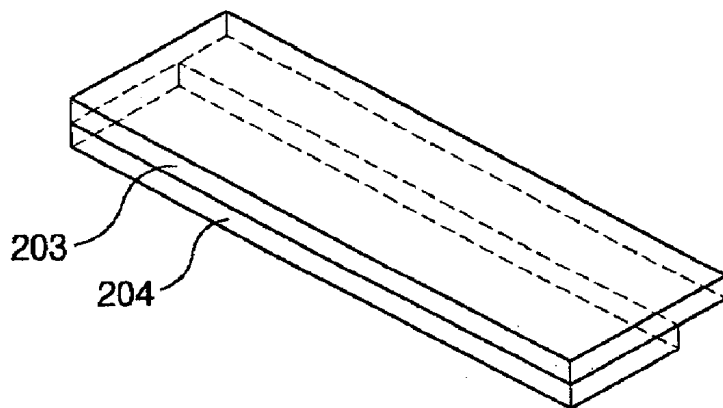

FIG. 7E

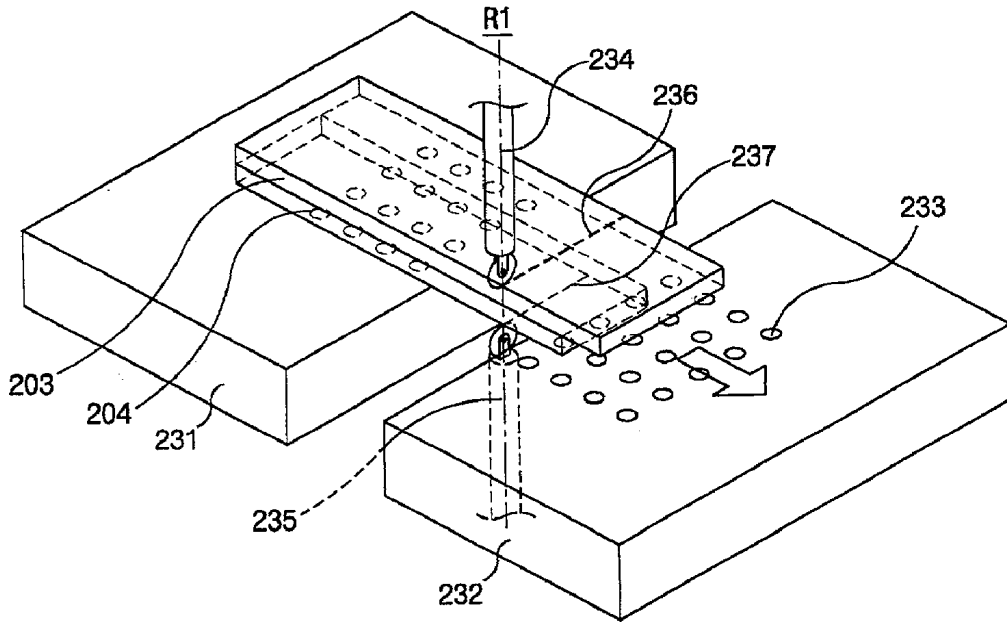

FIG. 7F

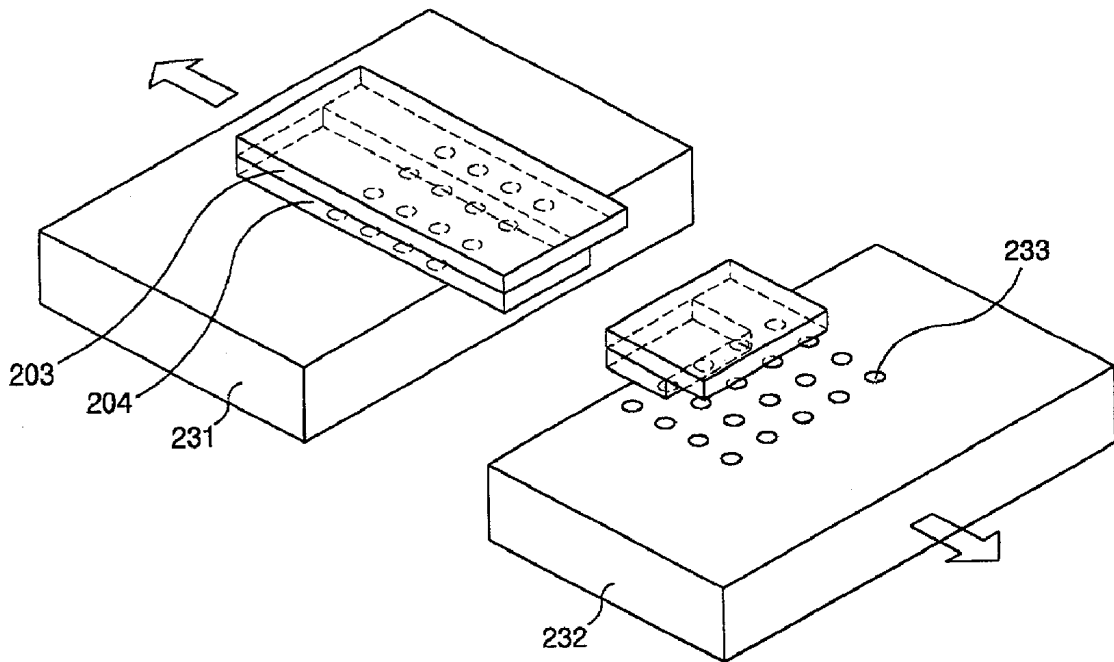

FIG. 7G

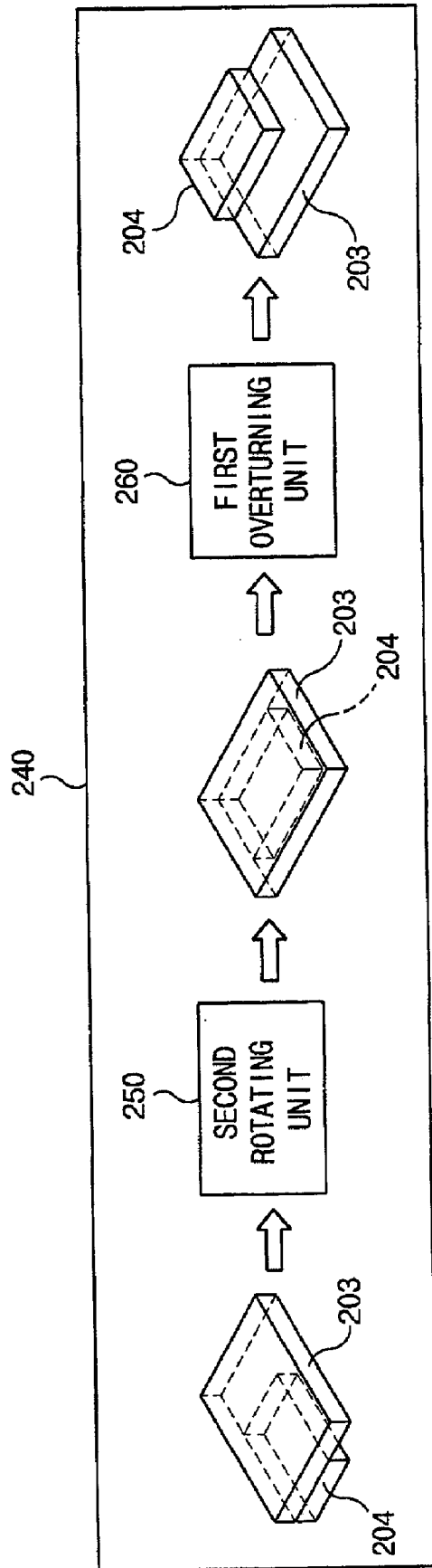

FIG. 8

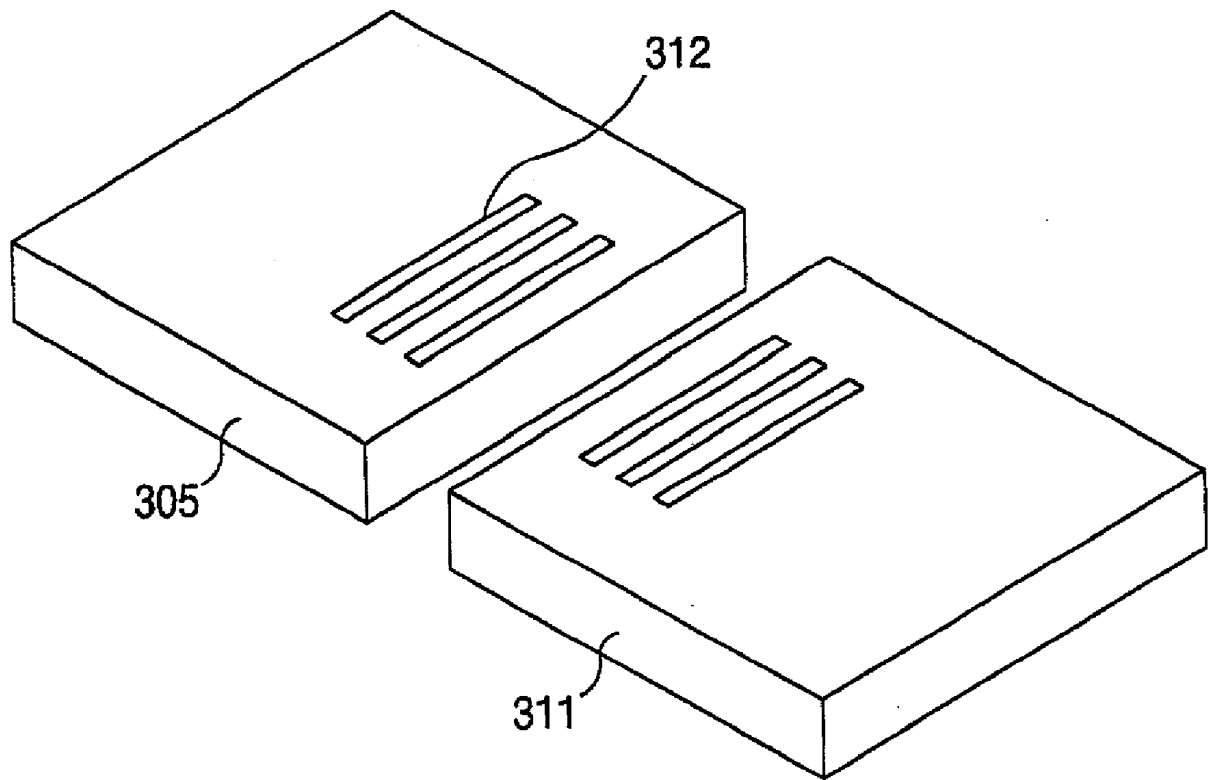

FIG. 9A

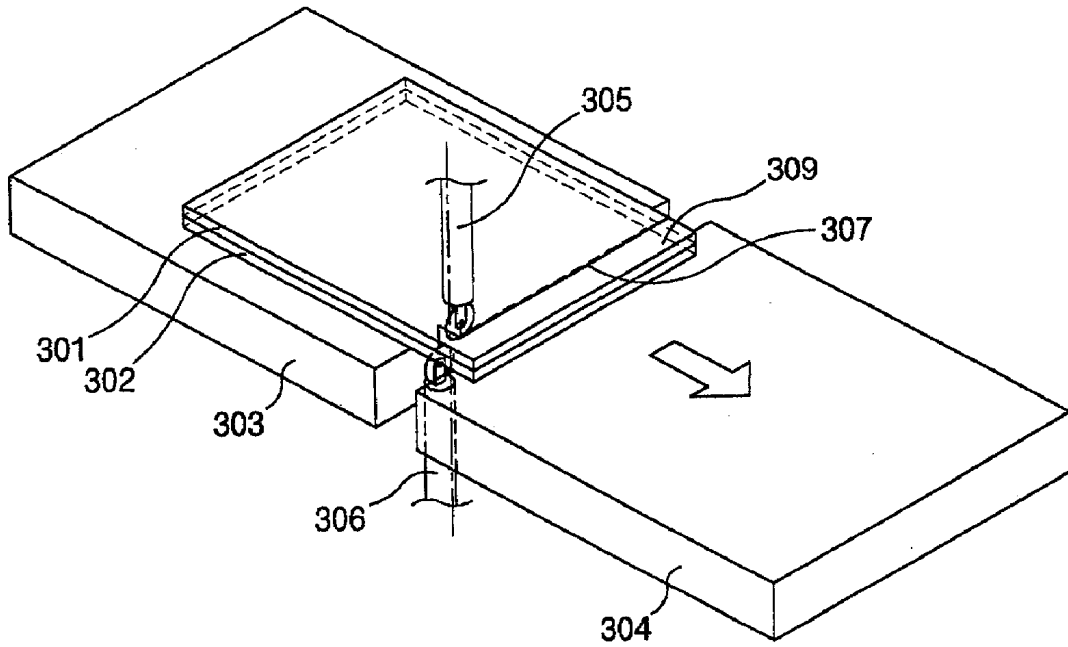

FIG. 9B

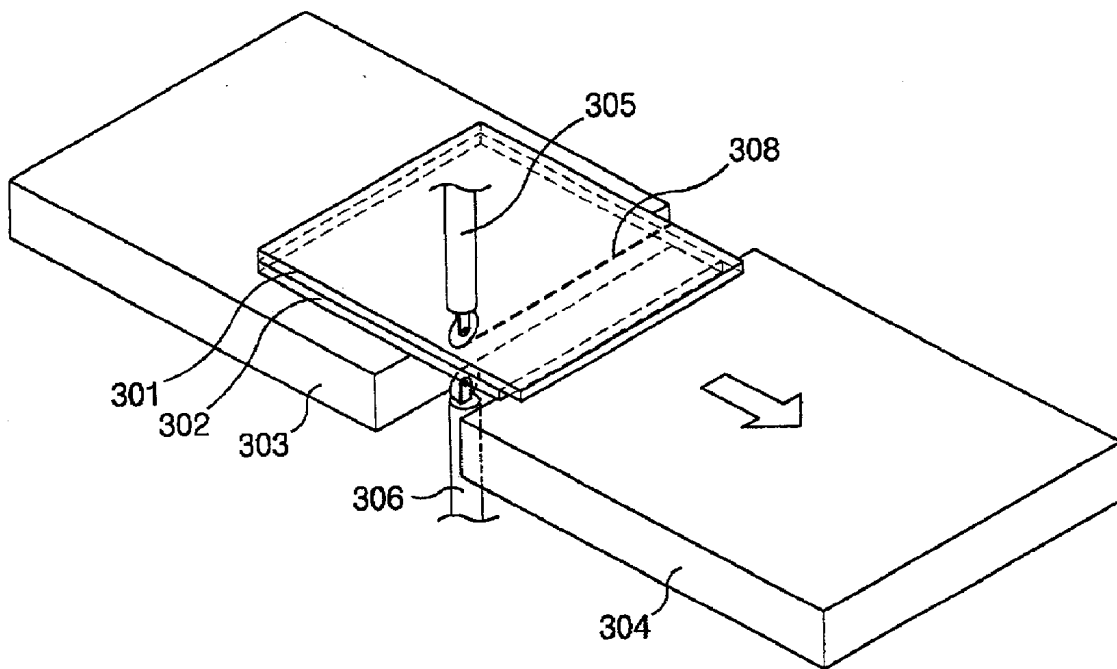

FIG. 10A

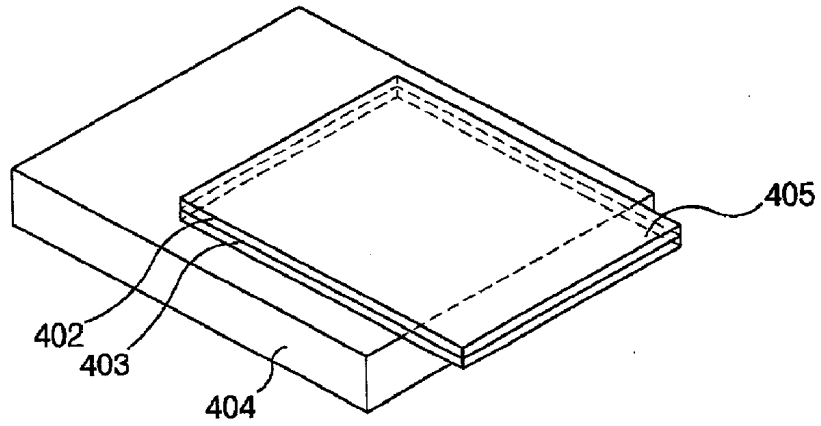

FIG. 10B

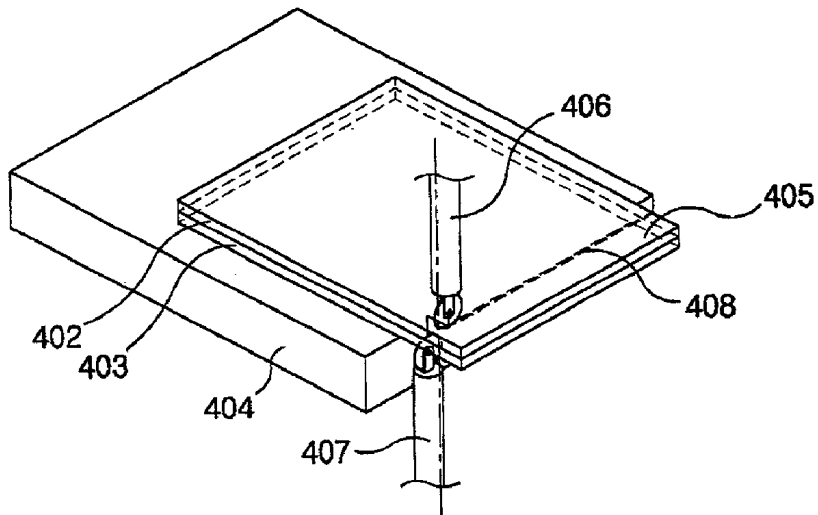

FIG. 10C

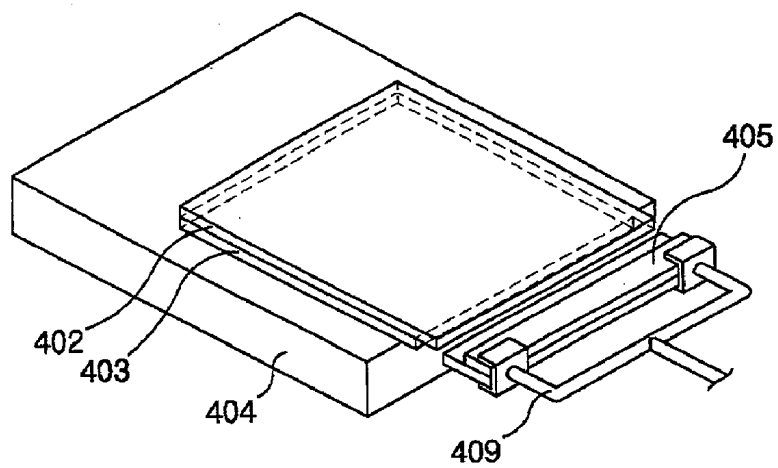

FIG. 10D

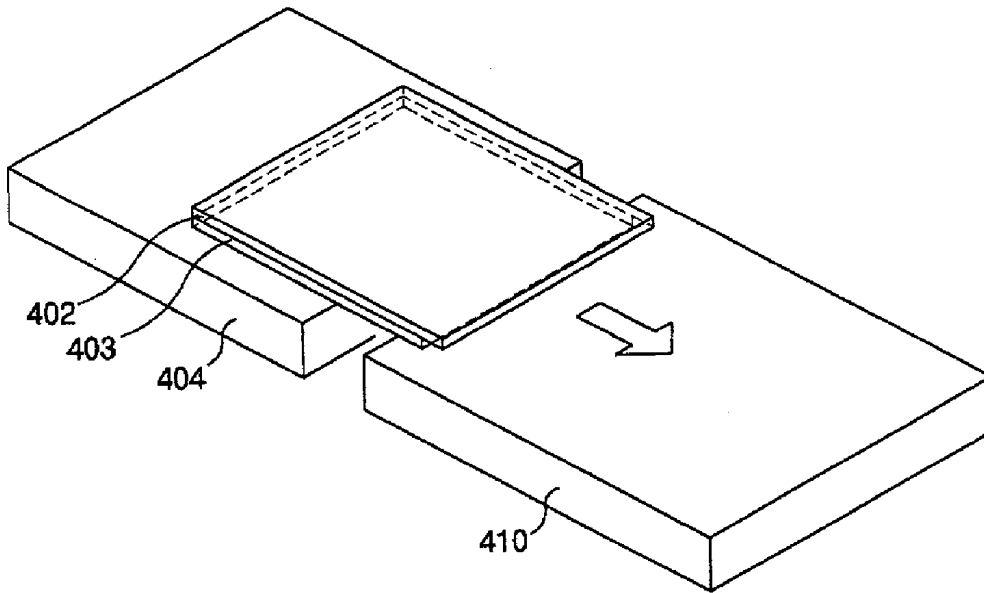

FIG. 10E

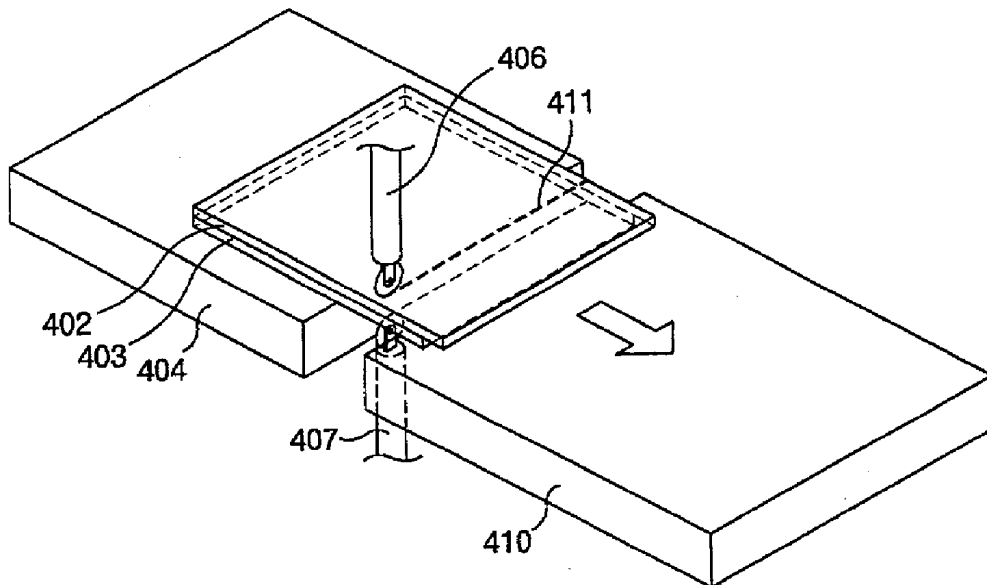
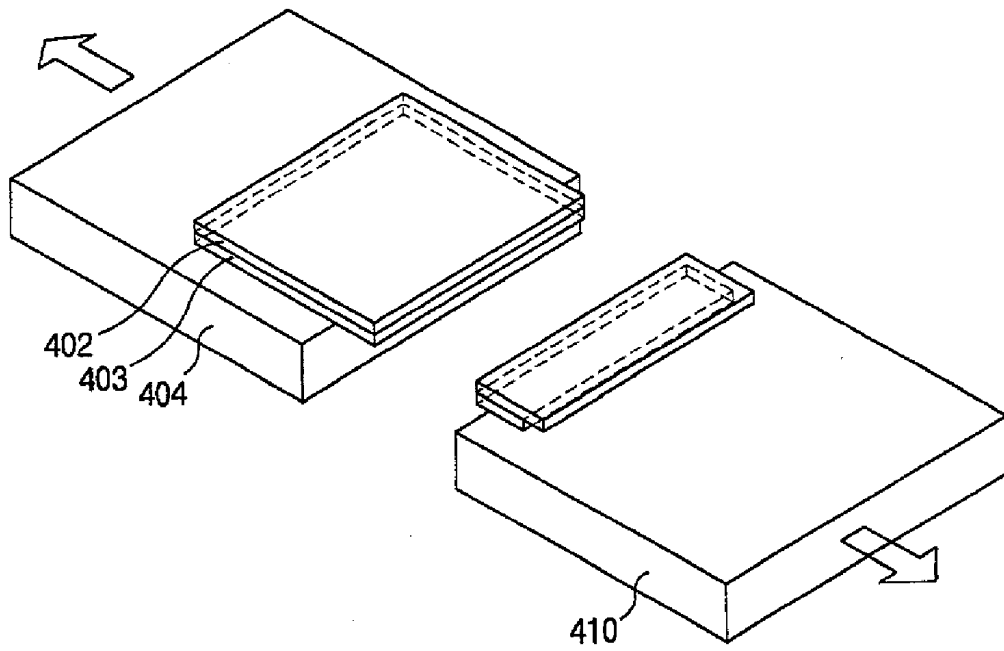

FIG. 10F



**DEVICE FOR CUTTING LIQUID CRYSTAL
DISPLAY PANEL AND METHOD FOR CUTTING
USING THE SAME**

[0001] This application claims the benefit of the Korean Patent Application No. P2002-07774 filed on Feb. 9, 2002, which is hereby incorporated by reference.

BACKGROUND OF THE INVENTION

[0002] 1. Field of the Invention

[0003] The present invention relates to a liquid crystal display panel, and more particularly, to a device for cutting a liquid crystal display panel and a method for cutting using the same to separate a unit liquid crystal display panel from the mother substrate.

[0004] 2. Discussion of the Related Art

[0005] In general, a liquid crystal display device displays a desired picture by individually supplying a data signal according to picture information to the liquid crystal cell arranged in a matrix form and controlling light transmittance of the liquid crystal cells.

[0006] The liquid crystal display device includes a liquid crystal display panel on which liquid crystal cells of a pixel unit are arranged in a matrix form, and a driver integrated circuit (IC) for driving the liquid crystal cells.

[0007] The liquid crystal display panel includes a color filter substrate and a thin film transistor array substrate that are facing into each other and a liquid crystal filled between the color filter substrate and the thin film transistor array substrate.

[0008] On the thin film transistor array substrate of the liquid crystal display panel, there are a plurality of data lines for transmitting a data signal supplied from a data driver integrated circuit to the liquid crystal cell and a plurality of gate lines for transmitting a scan signal supplied from a gate driver integrated circuit to the liquid crystal cells. The liquid crystal cells are defined at each portion where the data lines and the gate lines cross each other.

[0009] The gate driver integrated circuit sequentially supplies a scan signal to the plurality of gate lines so that the liquid crystal cells arranged in a matrix form are sequentially selected line by line. A data signal is supplied from the data driver integrated circuit to the selected line of the liquid crystal cells.

[0010] Meanwhile, a common electrode and a pixel electrode are formed the color filter substrate and the thin film transistor array substrate to face into each other for applying an electric field to the liquid crystal layer.

[0011] The pixel electrode is formed by liquid crystal cells on the thin film transistor array substrate, while the common electrode is integrally formed on the entire surface of the color filter substrate.

[0012] Accordingly, by controlling a voltage applied to the pixel electrode while a voltage is applied to the common electrode, the light transmittance of the liquid crystal cells is individually controlled.

[0013] In order to control the voltage applied to the pixel electrode by each liquid crystal cell, a thin film transistor used as a switching device is formed at each liquid crystal cell.

[0014] To improve yield in fabricating a liquid crystal display device, a plurality of thin film transistor array substrates are formed on one large mother substrate, and a plurality of color filter substrates are formed on the other mother substrate. The two mother substrates are the attached to simultaneously form the plurality of liquid crystal display panels. Thus, a process for cutting the liquid crystal display panel into a plurality of unit panels is required.

[0015] Cutting the liquid crystal display panel is performed by a scribing process for forming a scribing line on the surface of the mother substrate with a pen made of diamond having a hardness higher than that of glass and a breaking process for cutting by applying a mechanical force along the scribing line.

[0016] The cutting process will now be described in detail with reference to the accompanying drawings.

[0017] **FIG. 1** is a schematic plane view showing a unit liquid crystal display panel formed with a thin film transistor array substrate **1** and a color filter substrate **2** attached to face into each other.

[0018] In **FIG. 1**, the liquid crystal display panel **10** includes a picture display unit **13** having a plurality of liquid crystal cells arranged in a matrix form, a gate pad unit **14** connected to a plurality of gate lines of the picture display unit **13**, and a data pad unit **15** connected to the gate pad unit **14** and a plurality of data lines.

[0019] The gate pad unit **14** and the data pad unit **15** are formed at the marginal portion of the thin film transistor array substrate **1**. The portion does not overlap the color filter substrate **2**.

[0020] The gate pad unit **14** supplies a scan signal supplied from the gate driver integrated circuit to the gate lines of the picture display unit **13**. The data pad unit **15** supplies picture information supplied from the data driver integrated circuit to the data lines of the picture display unit **13**.

[0021] The data lines receiving the picture information and the gate lines receiving the scan signal are disposed to be crossed orthogonally on the thin film transistor array substrate **1** of the picture display unit **13**. At the crossed portion, a thin film transistor is formed for switching the liquid crystal cells, and a pixel electrode is formed to be connected to the thin film transistor for driving the liquid crystal cell. Further, a protective film is formed at the entire surface to protect the electrode and the thin film transistor.

[0022] At the color filter substrate **2** of the picture display unit **13**, a plurality of color filters are coated to be separated by cell regions with a black matrix, and a common transparent electrode to the pixel electrode are formed at the thin film transistor array substrate **1**.

[0023] A cell gap is formed between the thin film transistor array substrate **1** and the color filter substrate **2** so that the two substrates are spaced apart and face into each other. The thin film transistor array substrate **1** and the color filter substrate **2** are attached by a sealant (not shown) formed at the exterior of the picture display unit **13**. A liquid crystal layer (not shown) is formed at the space between the thin film transistor array substrate **1** and the color filter substrate **2**.

[0024] **FIG. 2** is a cross-sectional view showing a plurality of unit liquid crystal display panels formed in the first

mother substrate having the thin film transistor array substrates **1** and the second mother substrate with the color filter substrate **2**.

[0025] As shown in **FIG. 2**, a plurality of unit panels are formed in such a manner that one side of the thin film transistor array substrate **1** is protruded as much as a dummy region **31**.

[0026] This is because the gate pad unit **14** and the data pad unit **15** are formed at the marginal portion where the thin film transistor array substrate **1** and the color filter substrate **2** do not overlap.

[0027] Thus, the color filter substrate **2** formed on the second mother substrate **30** is formed to be isolated as much as dummy regions **31** corresponding to the area that the thin film transistor array substrates **1** formed on the first mother substrate **20** are protruded.

[0028] Each unit panel is disposed at the first and second mother substrates **20** and **30** so that the first and the second mother substrates **20** and **30** are used at the maximum. Depending on a model, the unit liquid crystal display panels are generally formed to be isolated as much as the dummy region **32**.

[0029] After the first mother substrate **20** where the thin film transistor array substrates **1** are formed and the second mother substrate **30**, where the color filter substrates **2** are formed, are attached each other, the liquid crystal display panels are individually cut through the scribing process and the breaking process. The dummy regions **31** formed at the region where the color filter substrates **2** of the second mother substrate **30** are isolated. The dummy region **32** isolating the unit panels are simultaneously removed.

[0030] The cutting process to the unit panels will now be described with reference to **FIGS. 3A** to **3J**.

[0031] As shown in **FIG. 3A**, the first mother substrate **20** and the second mother substrate **30** are loaded on a first table **33**.

[0032] Next, as shown in **FIG. 3B**, the first table **33** is moved in one direction to sequentially form a plurality of first scribing lines **42** on the first mother substrate **20** with a cutting wheel **41**.

[0033] After first and second mother substrates **20** and **30** in **FIG. 3C** are rotated by 90°, the first table **33** is moved to its original position to sequentially form a plurality of second scribing lines **43** on the surface of the first mother substrate **20** through the cutting wheel **41**.

[0034] **FIG. 3D** illustrates the first and second mother substrates **20** and **30**, which are overturned and loaded on a second table **34**. While the second table **34** is moved in one direction, the second mother substrate **30** is pressed by a breaking bar **44** along the second scribing lines **43** so that a crack is transmitted on the first mother substrate **20**.

[0035] Next, as shown in **FIG. 3E**, second and first mother substrates **30** and **20** are rotated by 90°. While the second table **34** is moved to its original position, the second mother substrate **30** is pressed by the breaking bar **44** along the first scribing lines **42**, so that a crack is transmitted on the first mother substrate **20**.

[0036] As shown in **FIG. 3F**, the second and first substrates **30** and **20** are loaded on a third table **35**. A plurality of third scribing lines **46** are sequentially formed on the surface of the second mother substrate **30** with a cutting wheel **45** by moving the third table **35** in one direction.

[0037] Thereafter, the second and first mother substrates **30** and **20** are rotated by 90°, as shown in **FIG. 3G**. A plurality fourth scribing lines **47** are sequentially formed on the surface of the second mother substrate **30** with the cutting wheel **45** by moving the third table **35** to its original position.

[0038] As shown in **FIG. 3H**, second and first mother substrates **30** and **20** are overturned and loaded on the fourth table **36**. The first mother substrate **20** is pressed by a breaking bar **48** along the fourth scribing line **47** by moving the fourth table **36** in one direction, so that a crack is transmitted on the second mother substrate **30**.

[0039] Next, the first and second mother substrates **20** and **30** are rotated by 90°, as shown in **FIG. 3I**. The first mother substrate **20** is pressed by the breaking bar **48** along the third scribing line **46** by moving the fourth table **36** to its original position, so that a crack is transmitted on the second mother substrate **30**.

[0040] As shown in **FIG. 3J**, as the crack is transmitted on first and second mother substrates **20** and **30** along first through fourth scribing lines **42**, **43**, **46**, and **47**, unit panels are selectively unloaded by using a vacuum gripper **49** and conveyed to the equipment for next processes.

[0041] As mentioned above, in the conventional cutting device and cutting processes for the unit panel, scribing is performed four times and breaking is performed four times through four rotation processes and two overturning processes.

[0042] Thus, two scribing units including a rotating unit and two breaking units including a rotating unit and an overturning unit are required. These equipments would occupy much space in the working place. Thus, an installation expense and a space of the equipment are wasted.

[0043] In addition, much time is required for the scribing and breaking processes, resulting in a low productivity.

SUMMARY OF THE INVENTION

[0044] Accordingly, the present invention is directed to a device for cutting a liquid crystal display panel and a method for cutting using the same that substantially obviates one or more of problems due to limitations and disadvantages of the related art.

[0045] Another object of the present invention is to provide a device for cutting a liquid crystal display panel and a method for cutting using the same that is capable of minimizing the number of rotations and overturnings for cutting the unit panels from the mother substrate.

[0046] Additional features and advantages of the invention will be set forth in the description which follows and in part will be apparent from the description, or may be learned by practice of the invention. The objectives and other advantages of the invention will be realized and attained by the structure particularly pointed out in the written description and claims hereof as well as the appended drawings.

[0047] To achieve these and other advantages and in accordance with the purpose of the present invention, as embodied and broadly described, a device for cutting a liquid crystal display panel includes a first scribing unit for forming a first scribing line at first and second mother substrates by using first and pressing at least a portion of the first scribing line with a first roll, a second scribing unit for forming a second scribing line at the first and second mother substrates by using third and fourth wheels and pressing at least a portion of the second scribing line with a second roll, and a first rotating unit for rotating the first and second mother substrates to form the second scribing line.

[0048] In another aspect of the present invention, a device for cutting a liquid crystal display panel includes a first scribing unit for loading and holding first and second mother substrates between the first and second tables, forming a first scribing line on the first and second mother substrates with first and second wheels, and cutting the first and second mother substrates by moving the first and second tables, a first rotating unit for rotating the first and second mother substrates by 90°, and a second scribing unit for loading and holding the first and second mother substrates between the third and fourth tables, forming a second scribing line on first and second mother substrates with the third and fourth wheels to cut the first and second mother substrates by moving the third and fourth tables.

[0049] In another aspect of the present invention, a method for cutting a liquid crystal display panel includes forming a first scribing line at first and second mother substrates, pressing at least a portion of the first scribing line with a first roll to cut the first and second mother substrates, forming a second scribing line at the first and second mother substrates, and pressing at least a portion of the second scribing line with a second roll to cut the first and second mother substrates.

[0050] In a further aspect of the present invention, a method for cutting a liquid crystal display panel includes loading and holding first and second mother substrates between the first and second tables, forming a first scribing line at first and second mother substrates, cutting the first and second mother substrates by moving the first and second tables, loading and holding the first and second mother substrates between the third and fourth tables, forming a second scribing line at the first and second mother substrates, and cutting the first and second mother substrates by moving the third and fourth tables.

[0051] It is to be understood that both the foregoing general description and the following detailed description are exemplary and explanatory and are intended to provide further explanation of the invention as claimed.

BRIEF DESCRIPTION OF THE DRAWINGS

[0052] The accompanying drawings, which are included to provide a further understanding of the invention and are incorporated in and constitute a part of this application, illustrate embodiments of the invention and together with the description serve to explain the principle of the invention.

[0053] In the drawings:

[0054] **FIG. 1** is a plane view showing a unit liquid crystal display panel formed in the thin film transistor array sub-

strate and a color filter substrate for a liquid crystal display device, which are attached to face into each other in a facing manner;

[0055] **FIG. 2** is a cross-sectional view showing a plurality of liquid crystal display panels formed in the first mother substrate including the thin film transistor array substrates and the second mother substrate with the color filter substrate of **FIG. 1**;

[0056] **FIGS. 3A to 3J** illustrate sequential cutting processes of unit panels in accordance with a related art;

[0057] **FIG. 4** is a schematic block diagram of a device for cutting a liquid crystal display panel in accordance with a first embodiment of the present invention;

[0058] **FIGS. 5A to 5G** illustrate sequential processes in each block of **FIG. 4**;

[0059] **FIG. 6** is a schematic block diagram of a device for cutting a liquid crystal display panel in accordance with a second embodiment of the present invention;

[0060] **FIGS. 7A to 7G** illustrate sequential processes for performing each block of **FIG. 6**;

[0061] **FIG. 8** is a schematic view showing a plurality of vacuum suction holes formed at the first through the fourth tables of **FIGS. 7A to 7G**;

[0062] **FIGS. 9A and 9B** illustrate first and second scribing processes for cutting a liquid crystal display panel in the present invention; and

[0063] **FIGS. 10A to 10F** illustrate sequential processes for cutting a liquid crystal display panel in accordance with a third embodiment of the present invention.

DETAILED DESCRIPTION OF THE ILLUSTRATED EMBODIMENTS

[0064] Reference will now be made in detail to the illustrated embodiments of the present invention, examples of which are illustrated in the accompanying drawings. Wherever possible, the same reference numbers will be used throughout the drawings to refer to the same or like parts.

[0065] **FIG. 4** is a schematic block diagram of a device for cutting a liquid crystal display panel in accordance with a first embodiment of the present invention.

[0066] As shown in **FIG. 4**, the device for cutting a liquid crystal display panel includes a loading unit **100** for loading and aligning first and second mother substrates including a plurality of unit liquid crystal display panels thereon. A first scribing unit **110** is to form a first scribing line on the surface of the first and second mother substrates with a first upper wheel and a first lower wheel, and to press at least a portion of the first scribing line with a first roll in order to sequentially cut the first and second mother substrates. A first rotating unit **120** is to rotate the cut first and second mother substrates by 90°. A second scribing unit **130** is to form a second scribing line on the surface of the rotated first and second mother substrates with a second upper wheel and a second lower wheel and to press at least a portion of the second scribing line in order to sequentially cut the first and second mother substrates. An unloading unit **140** is to unload the unit liquid crystal display panels cut by the first and

second scribing units **110** and **130** and to convey to the equipment for the following processes.

[0067] FIGS. 5A to 5G illustrate sequential processes for performing each block of FIG. 4.

[0068] Initially referring to FIG. 5A, a loading unit **100** loads a first mother substrate **103** and a second mother substrate **104** that are attached to each other placed on a first table **105**. The first mother substrate includes a plurality of thin film transistor array substrates formed thereon, and the second mother substrate includes a plurality of color filter substrates formed thereon. The first and second mother substrates **103** and **104** are aligned through an alignment mark **106**.

[0069] When the first and second mother substrates **103** and **104** are loaded on the first table **105**, the first mother substrate **103** is stacked to be on the second mother substrate **104**. An impact to the thin film transistor array substrate or the color filter substrate in a cutting process of the first and second mother substrates **103** and **104** may be mitigated by this location.

[0070] As shown in FIG. 5B, the first scribing unit **110** sequentially forms first scribing lines **114** and **115** at the surface of the first and second mother substrates **103** and **104** through the first upper wheel **112** and the first lower wheel **113** located at the space between the first and second tables **105** and **111**. In this process, the first and second mother substrates **103** and **104** move to be placed between the first table **105** and the second table **111**.

[0071] One side of the thin film transistor array substrates formed at the first mother substrate **103** is protruded to be longer than the corresponding side of the color filter substrates formed at the second mother substrate **104**.

[0072] This is because the gate pad unit is formed at one of the horizontal sides and the data pad unit is formed at one of the vertical sides of the thin film transistor array substrate, as described above with reference to FIGS. 1 and 2.

[0073] Accordingly, at the protruded region of the thin film transistor array substrates longer than the corresponding side of the color filter substrates, the first scribing line **114** is formed at the surface of the first mother substrate **103** distanced from a reference line (R1) by using the first upper wheel **112**. The first scribing line **115** is formed at the surface of the second mother substrate **104** distanced from the reference line (R1) in the opposite direction corresponding to the first upper wheel **112** by using the first lower wheel **113**.

[0074] Meanwhile, at the region where a gate pad unit or the data pad unit of the thin film transistor array substrates are not formed, the first upper wheel **112** and the first lower wheel **113** are aligned to form the first scribing lines **114** and **115** at the surfaces of the first and second mother substrates **103** and **104**.

[0075] The first scribing unit **110** presses a portion of the first scribing lines **114** and **115** with the first roll **116** to sequentially cut the first and second mother substrates **103** and **104**, as shown in FIG. 5C.

[0076] The first roll **116** presses a portion or several portions of the first scribing line **114** formed by the first

upper wheel **112**. Thus, a crack is transmitted along the first scribing lines **114** and **115** on the first and second mother substrates **103** and **104**.

[0077] The first upper wheel **112** forms the first scribing line **114** at the surface of the first mother substrate **103** and is moved to the original position. The first roll **116** works with the first wheel **112** in motion, so that it may be applied along the first scribing line **114**.

[0078] The first roll **116** may be applied only to the first scribing line **115** formed at the surface of the second mother substrate **104**. Alternatively, it may be applied both to the first scribing lines **114** and **115** formed at the surfaces of the first and second mother substrates **103** and **104**.

[0079] The first roll **116** may be made of urethane so that it may be less slippery on a glass substrate when the first roll **116** is applied. The first roll **116** directly contacts the first mother substrate **103** having the thin film transistor array substrate formed thereon. Also, a urethane material has an excellent characteristic in static electricity and generates less amount of particles upon contacting with the substrate.

[0080] As shown in FIG. 5D, the first rotating unit **120** rotates the first and second mother substrates **103** and **104** by 90°.

[0081] In FIG. 5E, the second scribing unit **130** sequentially forms second scribing lines **135** and **136** at the surfaces of the first and second mother substrates **103** and **104** with a second upper wheel **133** and a second lower wheel **134** located at the space between the third and fourth tables **131** and **132**. In this process, the rotated first and second mother substrates **103** and **104** move to be positioned between third and fourth tables **131** and **132**.

[0082] In the same manner with the first upper wheel **112** and the first lower wheel **113**, as described above with reference to FIG. 5B, the second upper wheel **133** and the second lower wheel **134** form the second scribing lines **135** and **136** at the surfaces of the first and second mother substrates **103** and **104**. They are isolated with each other for a certain distance in the opposite direction from the reference line R1 at the region where one side of the thin film transistor array substrates is protruded to be longer than the corresponding side of the color filter substrates.

[0083] Meanwhile, at the region where the thin film transistor array substrates are not protruded to be longer than the color filter substrates, the second upper wheel **133** and the second lower wheel **134** are aligned to form the second scribing lines **135** and **136** at the surfaces of the first and second mother substrates **103** and **104**.

[0084] As shown in FIG. 5F, the second scribing unit **130** presses a portion of the second scribing lines **135** and **136** with a second roll **137** to sequentially cut out the first and second mother substrates **103** and **104**.

[0085] In the same manner with the second roll **137** and the first roll **116** as described above with reference to FIG. 5C, one portion or several portions of the second scribing line **135** formed by the second upper wheel **133** is simultaneously pressed, so that a crack is transmitted along the second scribing lines **135** and **136** on the first and second mother substrates **103** and **104**.

[0086] In this respect, after the second upper wheels **133** forms second scribing line **135** at the surface of the first

mother substrate **103**, the second roll **137** is moved to the original position while it presses along the second scribing line **135** by working with the second upper wheel **133**. Thus, the second scribing line **135** is more effectively pressed.

[0087] The second roll **137** may be made of urethane since it has a little frictional force with a glass substrate and thus has an excellent characteristic in static electricity. Moreover, it generates a little amount of particles upon contacting with the glass substrate.

[0088] As shown in FIG. 5G, the unloading unit **140** conveys the unit liquid crystal display panels sequentially cut along the first and second scribing lines **114**, **115**, **135**, and **136** to the equipment for the following processes.

[0089] The sequentially cut unit panels is rotated by 90° compared to the direction of the loading unit **100**. Thus, as shown in FIG. 5G, the unit panels are rotated by 90° by inserting the second rotating unit **150** into the unloading unit **140** and unloaded to the equipment for the following processes. Thus, the present invention facilitates the following processes.

[0090] In addition, when the color filter substrate should be stacked on the thin film transistor array substrate in the following processes, as shown in FIG. 5G, after the unloaded unit panels are overturned by inserting the first overturning unit **160** into the unloading unit **140**, they are conveyed to the equipment for the following processes.

[0091] As mentioned above, according to the device for cutting a liquid crystal display panel and the method for cutting using the same of the present invention, the first and second mother substrates are cut into the unit panels in such a manner that at least one portion of the first and second scribing lines is pressed with the first and second rolls while the first and second scribing lines are formed through one rotation process, and two simultaneous scribing processes of the first and second mother substrates.

[0092] Meanwhile, the thin film transistor array substrate and the color filter substrate attached to each other are fabricated to be separated apart on the first and second mother substrates. A dummy seal pattern may be formed at the exterior of the first and second mother substrates where unit panels are not formed, so as to prevent a distortion of the attached first and second mother substrates depending on the model of the liquid crystal display device.

[0093] However, when the first and second mother substrates having a dummy seal pattern is cut by using the first embodiment of the present invention, the first and second mother substrates may not be easily separated from each other.

[0094] FIG. 6 is a schematic block diagram of a device for cutting a liquid crystal display panel to effectively cut and separate first and second mother substrates having a dummy seal pattern in accordance with a second embodiment of the present invention.

[0095] As shown in FIG. 6, the device of a liquid crystal display panel in accordance with the second embodiment of the present invention includes a loading unit **200** for loading and aligning first and second mother substrates where a plurality of unit liquid crystal display panels are formed thereon. The first and second mother substrates are placed on the first table. A first scribing unit **210** is to load and hold the

first and second mother substrates by vacuum suction so that it is placed on both the first table and the second table that are spaced apart by a certain distance. A first scribing line is formed at the surface of the first and second mother substrates with the first upper wheel and the first lower wheel. The first and second mother substrates are sequentially cut by moving the first and second tables in the direction so that they become distant from each other. A first rotating unit **220** is to rotate the cut first and second mother substrates by 90°. A second scribing unit **230** is to load and hold the rotated first and second mother substrates by vacuum suction to be bridged between the third and fourth tables that are spaced apart by a certain distance. The second scribing line is formed at the surface of the first and second mother substrates with the second upper wheel and the second lower wheels. The first and second mother substrates are sequentially cut by moving the third and fourth tables in a direction that they become distant from each other. An unloading unit **240** is to unload the unit liquid crystal display panel cut and separated by the first and second scribing units **210** and **230** and to convey to the equipment for the following processes.

[0096] FIGS. 7A to 7G illustrate sequential processes for performing each block of FIG. 6.

[0097] Initially referring to FIG. 7A, the loading unit **200** loads the first mother substrate **203** and the second mother substrate **204** that are attached to each other. The first mother substrate includes a plurality of thin film transistor array substrates formed thereon and the second mother substrate includes a plurality of color filter substrates formed thereon. They are placed on a first table **205** and aligned through an alignment mark **206**.

[0098] If the first and second mother substrates **203** and **204** are stacked on the second mother substrate **204**, an impact caused in the cutting process to the thin film transistor array substrate or the color filter substrate may be mitigated.

[0099] As shown in FIG. 7B, the first scribing unit **210** loads the first and second mother substrates **203** and **204**, so as to be bridged between the first table **205** and the second table **211** that are spaced apart from each other. The first scribing unit **210** also holds the substrates **203** and **204** through a plurality of vacuum suction holes **212**, and sequentially forms the first scribing lines **215** and **216** at the surfaces of the first and second substrates **203** and **204** through the first upper wheel **213** and the first lower wheel **214** located at the space between the first and the second tables **205** and **211**.

[0100] One side of the thin film transistor array substrates formed at the first mother substrate **203** is protruded to be longer than to the corresponding side of the color filter substrates formed on the second mother substrate **204**.

[0101] This is because the gate pad unit is formed at one of the horizontal sides and the data pad unit is formed at one of the vertical sides of the thin film transistor array substrate, as described above with reference to FIGS. 1 and 2.

[0102] Accordingly, at the protruded region of the thin film transistor array substrates, the first scribing line **215** is formed at the surface of the first mother substrate **203** distanced from one side of a reference line (R1) by using the first upper wheel **213**. The first scribing line **215** is formed at the surface of the second mother substrate **204** distanced

from the reference line (R1) in the opposite direction corresponding to the first upper wheel 213 by using the first lower wheel 214.

[0103] Meanwhile, at the region where a gate pad unit or the data pad unit of the thin film transistor array substrates are not formed, the first upper wheel 213 and the first lower wheel 214 are aligned to each other, so as to form the first scribing lines 215 and 216 at the surfaces of the first and second mother substrates 203 and 204.

[0104] In FIG. 7C, the first scribing unit 210 moves the first and second tables 205 and 211 on which the first and second mother substrates 203 and 204 are held by the plurality of vacuum suction holes 212 in a direction that they become distant from each other. Thereafter, the first and the second mother substrates 203 and 204 are cut and separated along the first scribing lines 215 and 216.

[0105] The vacuum suction holes 212 may be formed to be separated at constant intervals at the surfaces of the first and second tables 205 and 211. The first and second mother substrates 203 and 204 are held onto the first and second tables 205 and 211 by sucking air and released from the first and second tables 205 and 211 by injecting air when the first and second mother substrates are conveyed to the next process.

[0106] Meanwhile, as shown in FIG. 8, the vacuum suction holes 212 may be formed as the vacuum suction unit 312 having a certain area at the surface of the first and second tables 305 and 311, thereby effectively holding the first and second mother substrates 203 and 204. If a suction pressure is too high, a black dot stain may occur at the first and the second mother substrates 203 and 204. This problem may be prevented by using the vacuum suction unit 321.

[0107] The first rotating unit 220 rotates the cut first and second mother substrates 203 and 204 by 90°, as shown in FIG. 7D.

[0108] The second scribing unit 230, in FIG. 7E, loads the rotated first and second mother substrates 203 and 204, so as to be bridged between the third and fourth tables 231 and 232 that are spaced apart by a certain distance. The first and second mother substrates 203 and 204 are held by the vacuum suction holes 233. The second scribing lines 236 and 237 are sequentially formed at the surface of the first and second mother substrates 203 and 204 through the second upper wheel 234 and the second lower wheel 235 located at the space between the third and fourth tables 231 and 232.

[0109] In the same manner with the first upper wheel 213 and the first lower wheel 214 as described above with reference to FIG. 7B, the second upper wheel 234 and the second lower wheel 235 form the second scribing lines 236 and 237 at the surfaces of the first and second mother substrates 203 and 204, so as to be isolated to each other by a certain distance in the opposite direction from the reference line R1, at the region where one side of the thin film transistor array substrates is protruded to be longer than the corresponding side of the color filter substrates.

[0110] Meanwhile, at the region where the thin film transistor array substrates are not protruded to be longer than the color filter substrates, the second upper wheel 234 and the second lower wheel 235 are aligned to each other, so as to

form the second scribing lines 236 and 237 at the surface of the first and second mother substrates 203 and 204.

[0111] As shown in FIG. 7F, the second scribing unit 230 moves the third and fourth tables 231 and 232 on which the first and second mother substrates 203 and 204 are held by the vacuum suction holes 233 in a direction that they become distant from each other. The first and second mother substrates 203 and 204 are cut and separated from each other along the second scribing lines 236 and 237.

[0112] The vacuum suction holes 233 formed at the surface of the third and fourth tables 231 and 232 are the same as the vacuum suction holes 212 formed at the surface of the aforementioned first and second tables 205 and 211. The vacuum suction holes 233 may have a different shape, such as the vacuum suction holes 312 having a rectangular shape, as illustrated in FIG. 8.

[0113] In FIG. 7G, the unloading unit 240 conveys the unit liquid crystal display panels that are sequentially cut along the first and second scribing lines 215, 216, 236, and 237 to the equipment for the following processes.

[0114] The sequentially cut unit panels are rotated by 90° compared to the direction of the loading unit 200. Thus, as shown in FIG. 7G, the unit panels are rotated by 90° by inserting the second rotating unit 250 into the unloading unit 240 and unloaded to the equipment for the following processes for facilitating the following processes.

[0115] If the color filter substrate should be stacked on the thin film transistor array substrate for the following processes, as shown in FIG. 7G, after the unloaded unit panels are overturned by inserting the first overturning unit 260 into the unloading unit 240, they may be conveyed to the equipment for the following processes.

[0116] As mentioned above, according to the cutter for cutting a liquid crystal display panel and the method for cutting using the same of the present invention, the first and second mother substrates are cut into the unit liquid crystal display panels in such a manner that the first and second tables or the third and fourth tables, on which the loaded and held first and the second mother substrates, are moved in the direction that they become distant from each other, while the first and second scribing lines are formed through one rotation process, and two simultaneous scribing processes of the first and second mother substrates.

[0117] The first and second scribing processes respectively include cutting and removing a dummy region where the unit panels are not formed from the first and second mother substrates and cutting the region where the unit panels from the first and second mother substrates, which are alternately performed.

[0118] That is, as shown in FIG. 9A, after the first and second mother substrates 301 and 302 are moved to be bridged between the first and second tables 303 and 304 that are spaced apart by a certain distance, the first scribing line 307 is formed with the first upper wheel 305 and the first lower wheel 306. And then, similar to the first embodiment of the present invention, at least one portion of the first scribing line 307 is pressed with the roll. Alternatively, similar to the second embodiment of the present invention, the first and second tables 303 and 304 on which the held first and second mother substrates 301 and 302 are moved in

a direction that they become distant from each other. Then, the dummy region 309 at one side where the unit liquid crystal display panels are not formed is cut out from the first and second mother substrates 301 and 302.

[0119] As shown in FIG. 9B, the first and second mother substrates 301 and 302 without the dummy region 309 as being removed in the first cutting process are moved in one direction, so as to be bridged between the first and second tables 303 and 304. And then, the second scribing line 308 is formed with the first upper wheel 305 and the first lower wheel 306, and at least one portion of the first scribing line 308 is pressed with the roll, similar to the first embodiment of the present invention. Alternatively, the first and second tables 303 and 304 holding the first and second mother substrates 301 and 302 are moved in the opposite direction so that the unit panels are cut out from the first and second mother substrates 301 and 302.

[0120] Thereafter, the first cutting process is performed to cut out the dummy region 309 where no unit panel is formed from the first and second mother substrates 301 and 302. The second cutting process is performed to cut out the unit panels from the first and second mother substrates 301 and 302. The first and second cutting processes may be repeatedly performed.

[0121] In this respect, however, when the cutting processes are performed on the model having the dummy seal pattern to prevent distortion of the first and second mother substrates 301 and 302 at the exterior where no unit panel is formed, the dummy region 309 and the unit panels may not be completely separated in the first or second cutting process.

[0122] In addition, in the second cutting process in the second embodiment of the present invention, a unit panel is large enough to cut out the first and second mother substrates 301 and 302 held on the first and second tables 303 and 304. However, in the first cutting process, since the dummy region 309 is very narrow, it is difficult to hold the first and second mother substrates 301 and 302 by the first and second tables 303 and 304.

[0123] FIGS. 10A to 10F illustrate sequential processes for cutting a liquid crystal display panel in accordance with a third embodiment of the present invention.

[0124] First, as shown in FIG. 10A, first and second mother substrates including a plurality of unit panels formed thereon are loaded on a first table 404. And then, the first and second mother substrates 402 and 403 are moved in one direction, so that a dummy region 405 where no unit panel is formed is protruded from one side of the first table 404.

[0125] Next, as shown in FIG. 10B, a first scribing line 408 is formed at the surface of the first and second mother substrates protruded from the first table 404 by using first upper wheel 406 and first lower wheel 407.

[0126] And then, as shown in FIG. 10C, the dummy region 405 with no unit panel formed is removed from the first and second mother substrates 402 and 403 along the first scribing line 408 by using a robot grip 409.

[0127] In order to facilitate the removal of the dummy region 405 from the first and second mother substrates 402 and 403 with the robot grip 409, at least one portion of the first scribing line 408 is pressed with a roll, similar to the

first embodiment of the present invention, after the first scribing line 408 is formed with the first upper wheel 406 and the first lower wheel 407. Thus, a crack can be transmitted along the first scribing line 408.

[0128] Since the liquid crystal display panel differs in size according to the model of a liquid crystal display device, the robot grip 409 may have to be able to control the heights by using a sub motor.

[0129] When the first mother substrate 402 with the thin film transistor array substrates formed thereon is stacked on the second mother substrate 403 with the color filter substrates formed thereon, the robot grip 409 is positioned to be lower than the first and second mother substrates 402 and 403, so as to hold the dummy region 405, since the thin film transistor substrate is protruded to be longer than the color filter substrate. Conversely, the robot grip 409 is positioned to be higher than the first and second mother substrates 402 and 403, so as to hold the dummy region 405, so that an impact applied to the unit panel may be prevented in advance.

[0130] As shown in FIG. 10D, the first and second mother substrates 402 and 403 without the dummy region 405 are moved in one direction to be bridged between the first table 404 and the second table 410 that are spaced apart a certain distance.

[0131] As shown in FIG. 10E, a second scribing line 411 is formed at the surface of the first and second mother substrates 402 and 403 by using the first upper wheel 406 and the first lower wheel 407 located at the space between the first and second tables 404 and 410.

[0132] Next, as shown in FIG. 10F, the first and second tables 404 and 410 are moved in a direction that they become distant from each other. The unit panels are cut and separated from the first and second mother substrates 402 and 403 along the second scribing line 411.

[0133] In order to easily cut and separate the unit panels from the first and second mother substrates 402 and 403 after moving the first and second tables 404 and 410 in the opposite direction, the second scribing line 411 is formed through the first upper wheel 406 and the first lower wheel 407. Then, at least one portion of the second scribing line 411 is pressed with a roll so that a crack can be transmitted along the second scribing line 411.

[0134] As so far described, the device of a liquid crystal display panel and the method for cutting using the same in accordance with the present invention have the following advantages over the conventional art.

[0135] For example, referring back to the first embodiment of the present invention, the liquid crystal display panels may be cut into the unit liquid crystal display panels by forming the first and second scribing lines by one rotation process and two simultaneous scribing processes of the first and second mother substrates, and pressing a portion of or along the first and second scribing lines with the first and second rolls.

[0136] Thus, the time required for scribing may be minimized compared to that of the conventional art. Also, since an overturning unit for overturning the first and second mother substrates and a breaking unit for a crack transmission are not necessary, the time required for scribing, break-

ing, and overturning is reduced, thereby improving productivity. In addition, an installation expense and an installation space of equipment are effectively used.

[0137] Referring to the second embodiment of the present invention, the liquid crystal display panel may be cut into the unit liquid crystal display panels by forming the first and second scribing lines through one rotation process and two simultaneous scribing processes of the first and second mother substrates and moving the first and second table or the third and fourth tables, on which the first and second mother substrates in the opposite direction.

[0138] Thus, the unit panels may be more effectively cut out from the mother substrates. Especially, when the dummy seal pattern is formed to prevent distortion of the first and second mother substrates, the unit panels may be effectively cut out from the mother substrates.

[0139] Similarly, referring to the third embodiment of the present invention, in case that the dummy seal pattern is formed at the exterior where no unit panel is formed to prevent distortion of the first and second mother substrates, cutting of the unit panels may be effectively performed.

[0140] In addition, the dummy region having a small width may be held and processed without difficulty in the third embodiment of the present invention.

[0141] It will be apparent to those skilled in the art that various modifications and variations can be made in the cutter for cutting a liquid crystal display and the method for cutting using the same of the present invention without departing from the spirit or scope of the inventions. Thus, it is intended that the present invention covers the modifications and variations of this invention provided they come within the scope of the appended claims and their equivalents.

What is claimed is:

1. A device for cutting a liquid crystal display panel, comprising:

a first scribing unit for forming a first scribing line at first and second mother substrates by using first and second wheels and pressing at least a portion of the first scribing line with a first roll;

a second scribing unit for forming a second scribing line at the first and second mother substrates by using third and fourth wheels and pressing at least a portion of the second scribing line with a second roll; and

a first rotating unit for rotating the first and second mother substrates to form the second scribing line.

2. The device of claim 1, wherein the first mother substrate including a plurality thin film transistor substrates is stacked on the second mother substrate including a plurality of color filter substrates.

3. The device of claim 1, wherein the first wheel moves to form the first scribing line in a first direction and the first roll moves to press the first scribing line in a second direction.

4. The device of claim 1, wherein the first and second rolls are formed of urethane.

5. The device of claim 1, wherein the first rotating unit rotates the first and second mother substrates by 90°.

6. A device for cutting a liquid crystal display panel comprising:

a first scribing unit for loading and holding first and second mother substrates between first and second tables, forming a first scribing line on first and second mother substrates with first and second wheels, and cutting the first and second mother substrates by moving the first and second tables;

a first rotating unit for rotating the first and second mother substrates by 90°; and

a second scribing unit for loading and holding the first and second mother substrates between third and fourth tables, forming a second scribing line on the first and second mother substrates with the third and fourth wheels to cut the first and second mother substrates by moving the third and fourth tables.

7. The device of claim 6, wherein the first mother substrate including a plurality of thin film transistor substrates is stacked on the second mother substrates including a plurality of color filter substrates.

8. The device of claim 6, wherein at least one of the first to fourth tables has a plurality of vacuum suction holes for holding the substrate.

9. The device of claim 6, wherein at least one of the first to fourth tables has a vacuum suction unit.

10. A method for cutting a liquid crystal display panel, comprising:

forming a first scribing line at first and second mother substrates;

pressing at least a portion of the first scribing line with a first roll to cut the first and second mother substrates;

forming a second scribing line at the first and second mother substrates; and

pressing at least a portion of the second scribing line with a second roll to cut the first and second mother substrates.

11. The method of claim 10, wherein the first mother substrate including a plurality of thin film transistor substrates is stacked on the second mother substrate including a plurality of color filter substrates.

12. The method of claim 10, wherein the first and second rolls are formed of urethane.

13. The method of claim 10, wherein further comprising rotating the first and second mother substrates by 90° prior to the second scribing line.

14. A method for cutting a liquid crystal display panel, comprising:

loading and holding first and second mother substrates between first and second tables;

forming a first scribing line at first and second mother substrates;

cutting the first and second mother substrates by moving the first and second tables;

loading and holding the first and second mother substrates between third and fourth tables;

forming a second scribing line at the first and second mother substrates; and

cutting the first and second mother substrates by moving the third and fourth tables.

15. The method of claim 14, wherein the first mother substrates including a plurality of thin film transistor substrates is stacked on the second mother substrate including a plurality of color filter substrates.

16. The method of claim 14, further comprising rotating the first and second mother substrates by 90° prior to the loading and holding the first and second mother substrates between third and fourth tables.

17. The method of claim 14, wherein at least one of the first to fourth tables has a plurality of vacuum suction holes for holding the substrates.

18. The method of claim 14, wherein the at least one of the first to fourth tables has a vacuum suction unit.

19. A method for cutting a liquid crystal display panel, comprising:

holding first and second mother substrates to protrude a dummy region of the first and second mother substrates from a first table;

forming a first scribing line at the protruded first and second mother substrates with first upper and lower wheels;

removing the dummy region from the first and second mother substrates along the first scribing line by using a robot grip;

moving the first and second mother substrates without the dummy region between the first and second tables

spaced apart from each other to form a second scribing line at the first and second mother substrates by using the first upper and lower wheels; and

moving the first and second tables to cut the first and second mother substrates.

20. The method of claim 19, further comprising pressing at least a portion of one of the first and second scribing lines with a roll.

21. The method of claim 19, further comprising pressing one of the first and second scribing lines along the one of the first and second scribing lines with a roll.

22. The method of claim 20, wherein the roll is formed of urethane.

23. The method of claim 21, wherein the roll is formed of urethane.

24. The method of claim 19, wherein the first mother substrate including a plurality of thin film transistor substrates is stacked on the second mother substrate including a plurality of color filter substrates.

25. The method of claim 19, wherein at least one of the first and fourth tables has a plurality of vacuum suction holes for holding the substrates.

26. The method of claim 19, wherein at least one of the first to fourth tables has a vacuum suction unit.

* * * * *

专利名称(译)	用于切割液晶显示板的装置和使用该装置进行切割的方法		
公开(公告)号	US20030151717A1	公开(公告)日	2003-08-14
申请号	US10/126698	申请日	2002-04-22
[标]申请(专利权)人(译)	乐金显示有限公司		
申请(专利权)人(译)	LG.飞利浦液晶CO., LTD.		
当前申请(专利权)人(译)	LG DISPLAY CO., LTD.		
[标]发明人	SHIN SANG SUN		
发明人	SHIN, SANG-SUN		
IPC分类号	G02F1/13 C03B33/07 G02F1/1333		
CPC分类号	G02F1/133351 C03B33/07 Y02P40/57 Y10T83/0378 Y10T225/325		
优先权	1020020007774 2002-02-09 KR		
其他公开文献	US6774978		
外部链接	Espacenet USPTO		

摘要(译)

一种用于切割液晶显示面板的装置，包括：第一划线单元，用于通过使用第一和第二轮在第一和第二母基板处形成第一划线，并且用第一辊，第二辊按压第一划线的至少一部分划线单元，用于通过使用第三和第四轮在第一和第二母基板处形成第二划线，并且用第二辊压制第二划线的至少一部分，以及用于旋转第一和第二母基板的第一旋转单元形成第二条划线。

