



US008294848B2

(12) **United States Patent**
Cho et al.

(10) **Patent No.:** **US 8,294,848 B2**
(45) **Date of Patent:** **Oct. 23, 2012**

(54) **LIQUID CRYSTAL DISPLAY HAVING LIGHT DIFFUSION LAYER**

(56) **References Cited**

(75) Inventors: **Don-Chan Cho**, Seongnam-si (KR);
Jae-Byung Park, Seongnam-si (KR);
Jin-Seob Byun, Seoul (KR); **Hae-Il Park**, Seoul (KR)

U.S. PATENT DOCUMENTS

7,661,841 B2 * 2/2010 Kurihara et al. 362/231
2002/0145685 A1 * 10/2002 Mueller-Mach et al. 349/61

FOREIGN PATENT DOCUMENTS

JP 2007-287697 11/2007
KR 1020070029526 3/2007
KR 1020070070052 7/2007

* cited by examiner

(73) Assignee: **Samsung Display Co., Ltd.**, Yongin (KR)

(*) Notice: Subject to any disclaimer, the term of this patent is extended or adjusted under 35 U.S.C. 154(b) by 653 days.

Primary Examiner — Mike Qi
(74) *Attorney, Agent, or Firm* — H.C. Park & Associates, PLC

(21) Appl. No.: **12/542,232**

(22) Filed: **Aug. 17, 2009**

(65) **Prior Publication Data**

US 2010/0079704 A1 Apr. 1, 2010

(30) **Foreign Application Priority Data**

Oct. 1, 2008 (KR) 10-2008-0096526
Apr. 6, 2009 (KR) 10-2009-0029496

(51) **Int. Cl.**
G02F 1/1335 (2006.01)

(52) **U.S. Cl.** **349/71; 349/112; 349/96; 349/97**

(58) **Field of Classification Search** **349/71, 349/112, 96, 97**

See application file for complete search history.

(57) **ABSTRACT**

A liquid crystal display includes, among others, a light diffusion layer comprising a color conversion media layer and a non-conversion layer arranged on the second substrate and a backlight assembly to supply light to the first substrate and the second substrate. The backlight assembly supplies various wavelengths of lights, including blue light or UV ray. The blue lights through the liquid crystal layer enters the color conversion media layers and may generates red lights and green lights. In this case, blue lights go through non-conversion layer and diffuse and scatter out blue lights. The UV rays through the liquid crystal layer enters the color conversion media layers and may generates red light, green lights and blue lights.

38 Claims, 12 Drawing Sheets

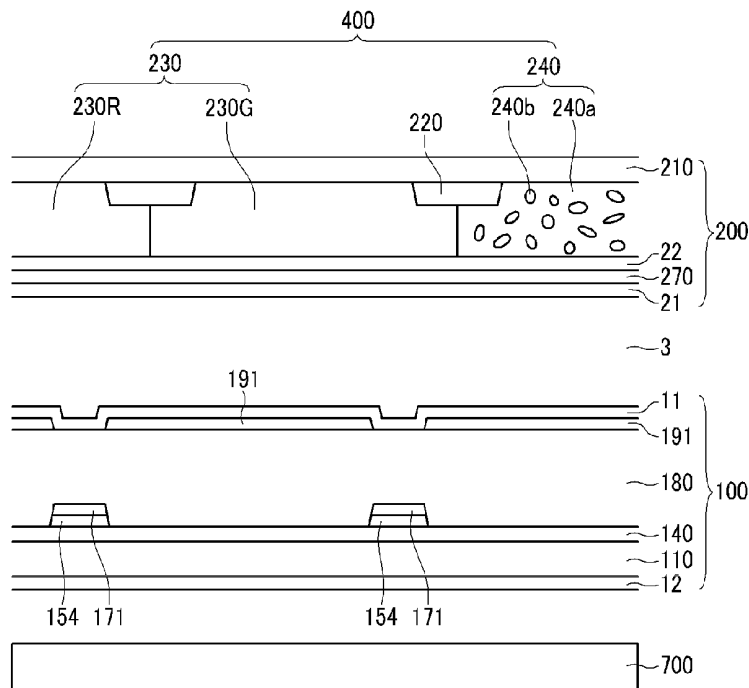

FIG. 1

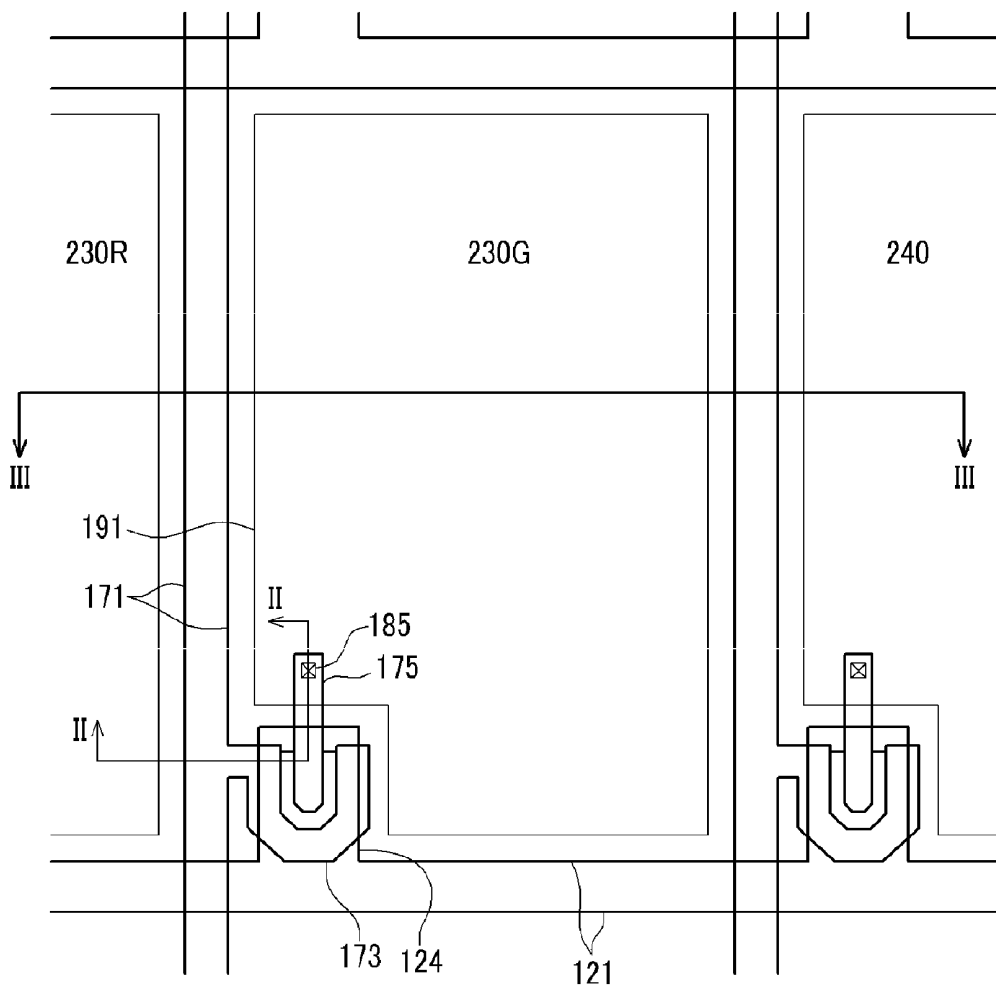

FIG. 2

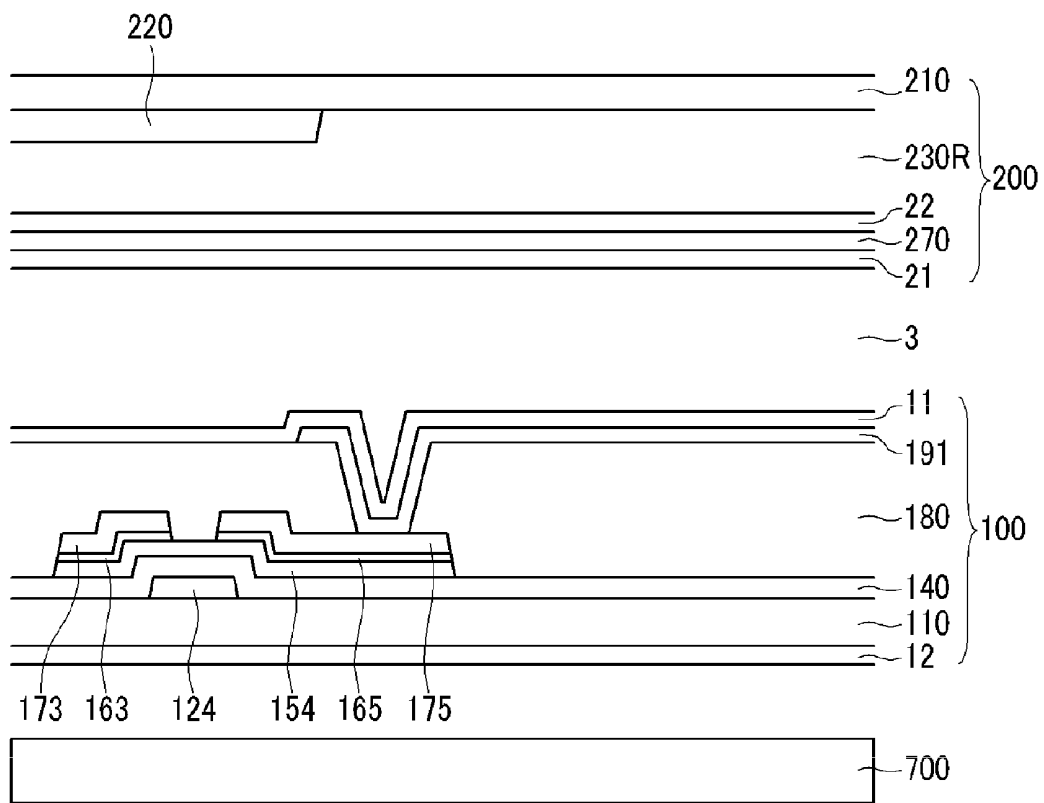

FIG. 3

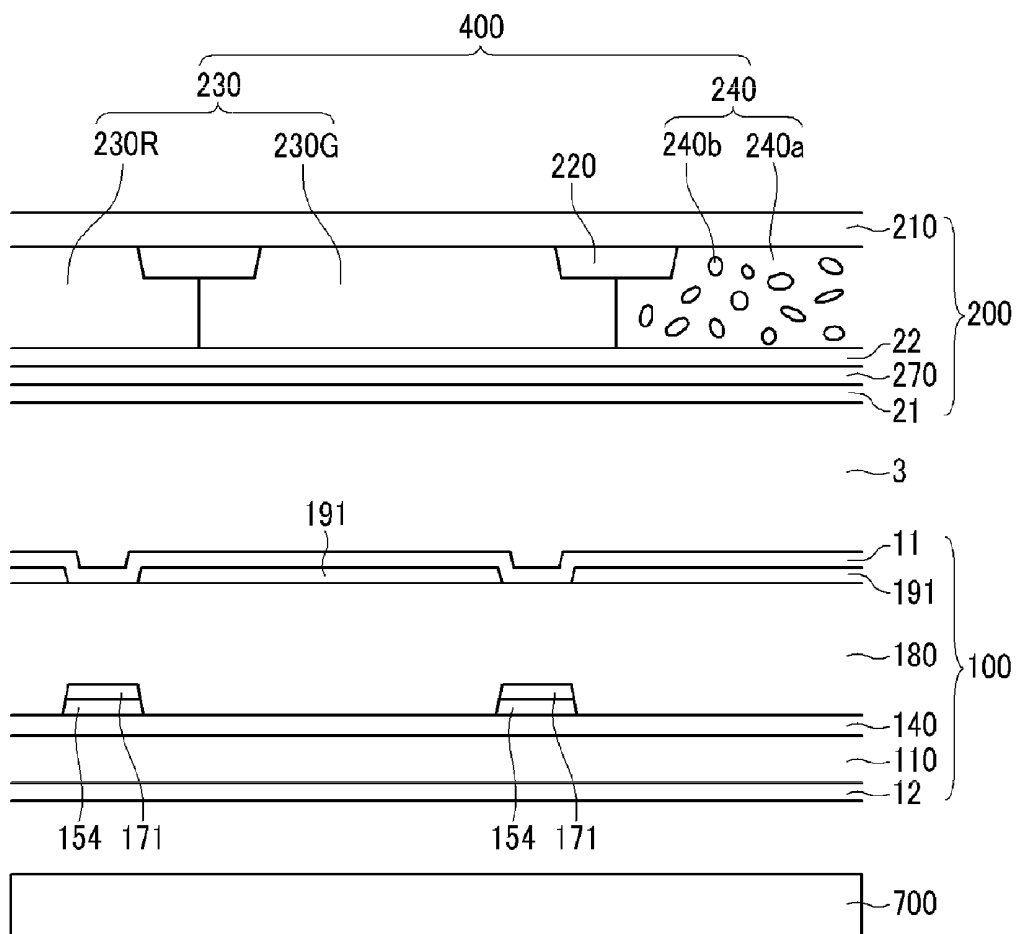

FIG. 4

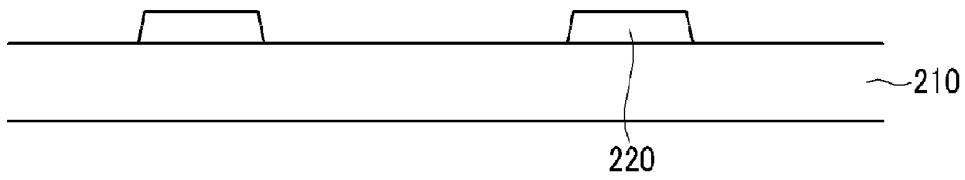

FIG. 5

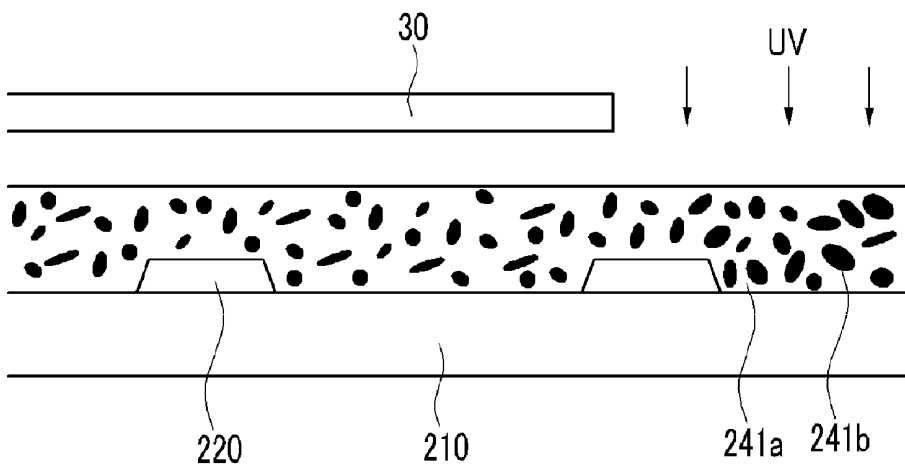

FIG. 6

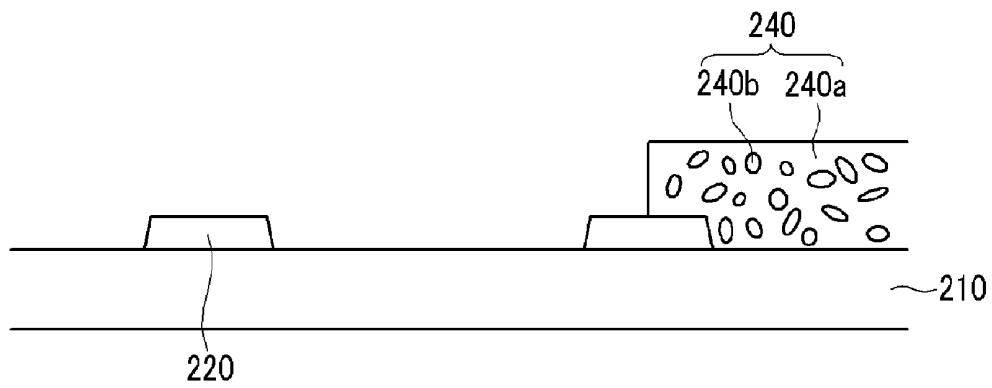

FIG. 7

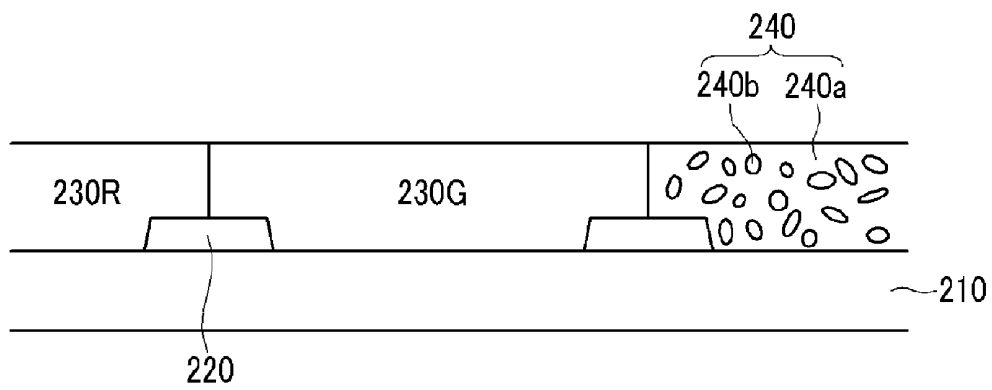

FIG. 8

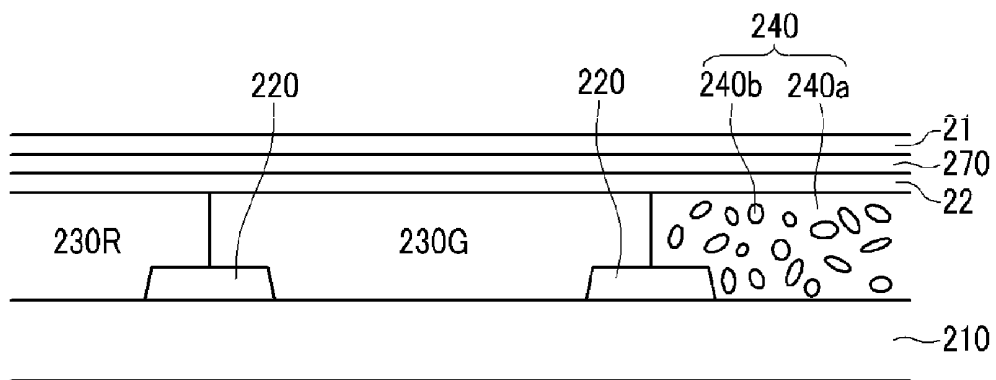

FIG. 9

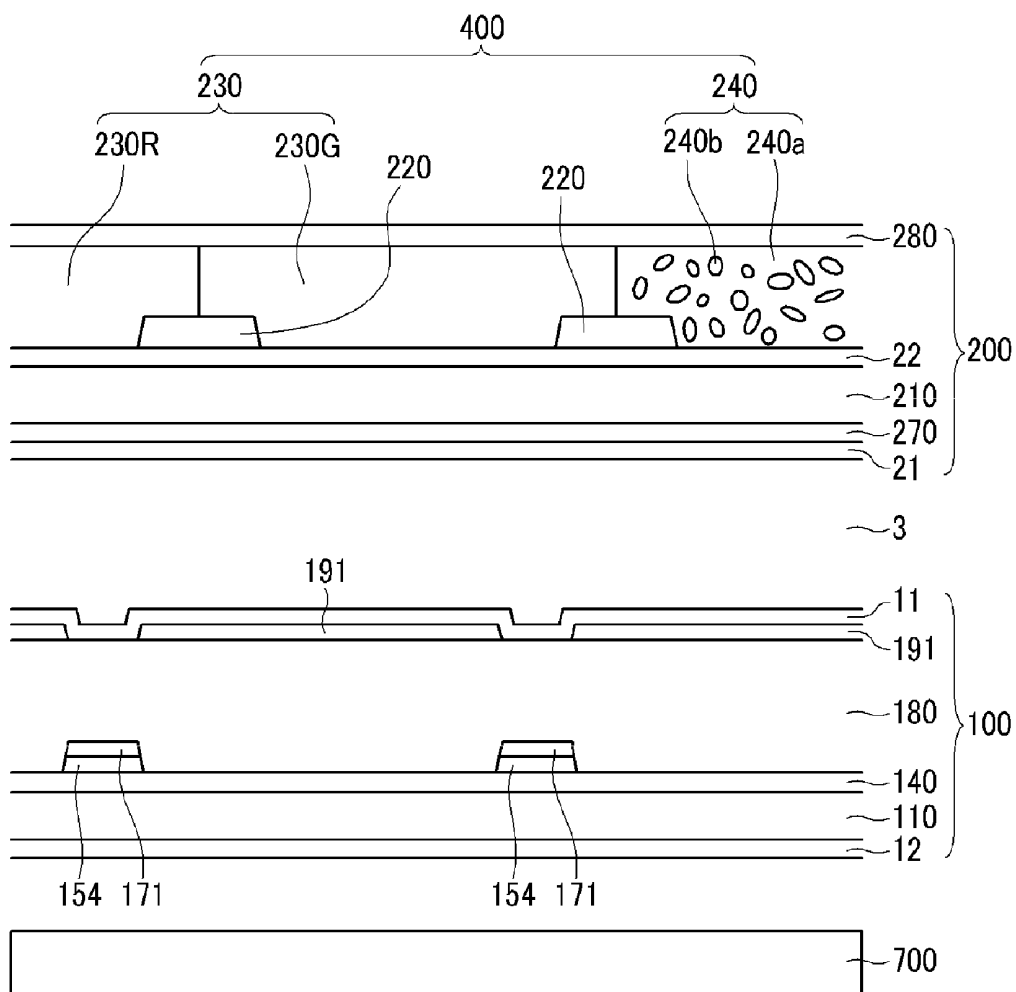

FIG. 10

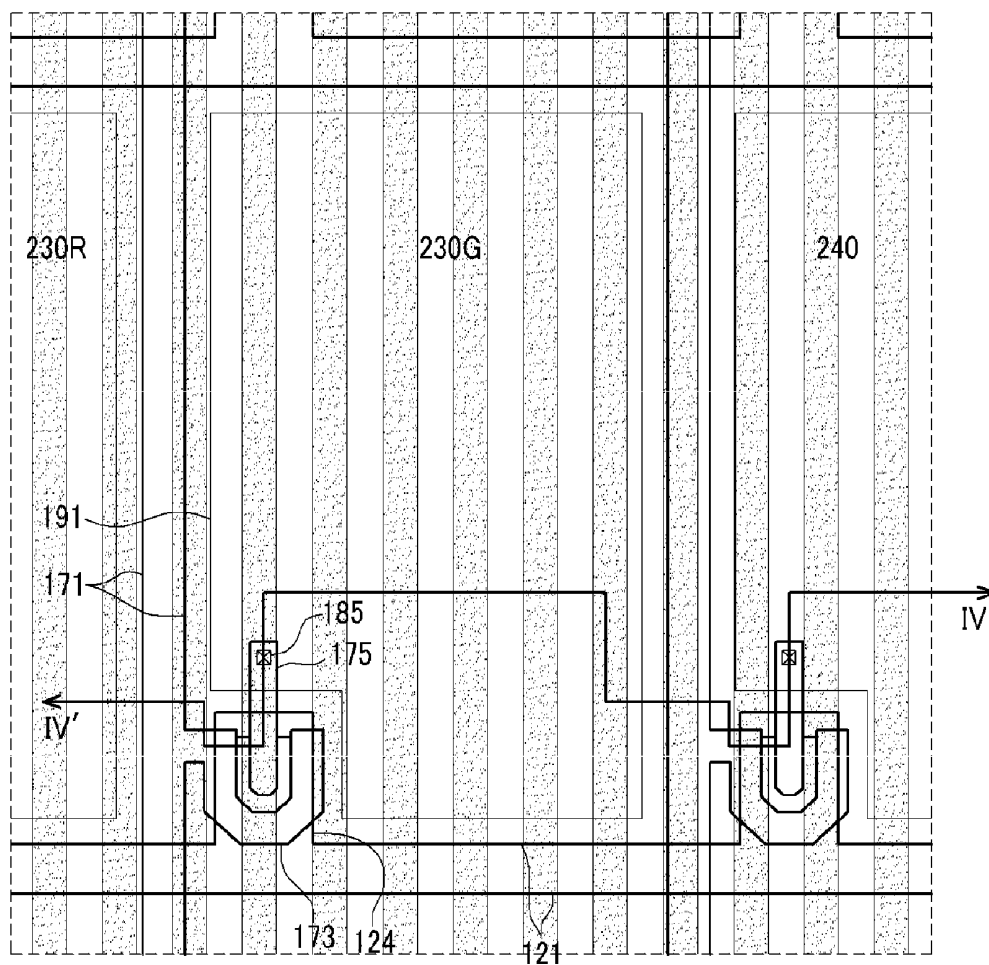

FIG. 12

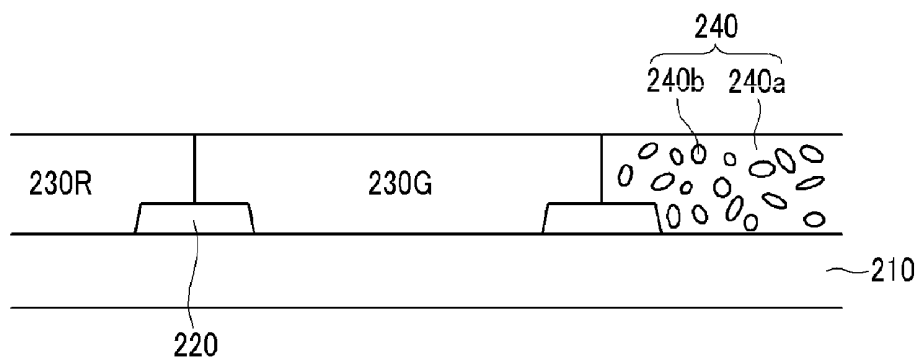

FIG. 13

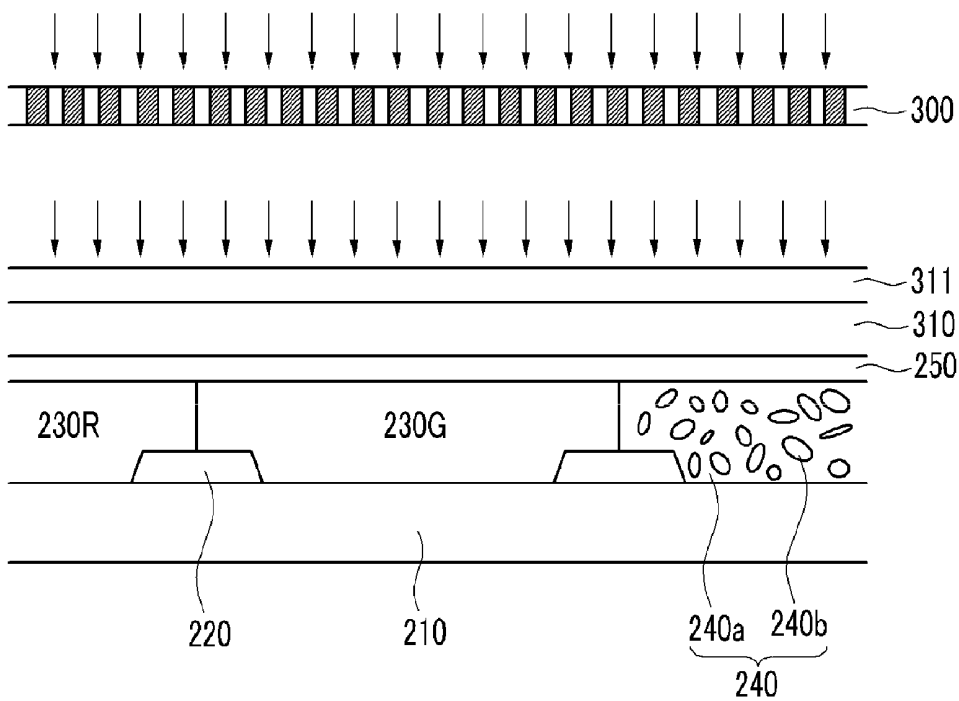

FIG. 14

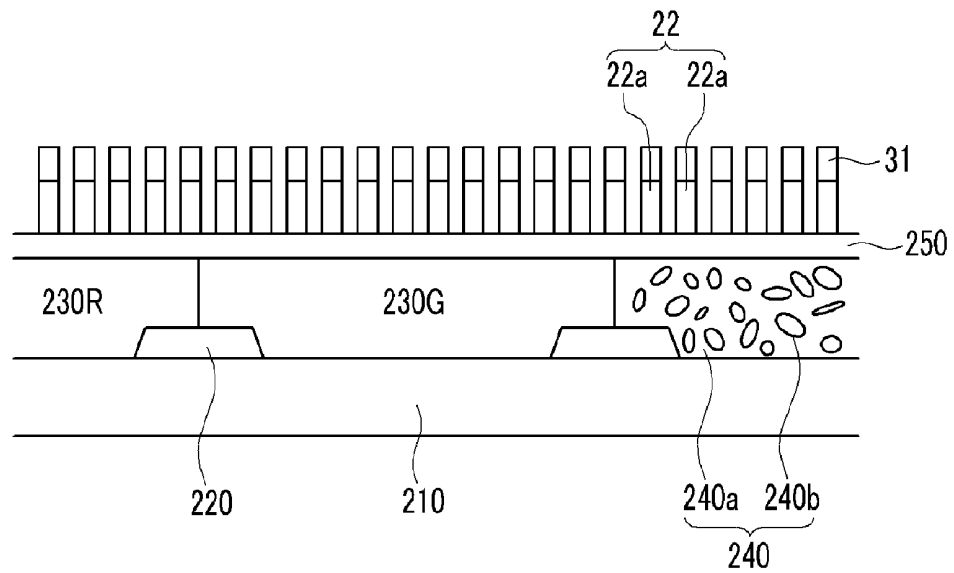

FIG. 15

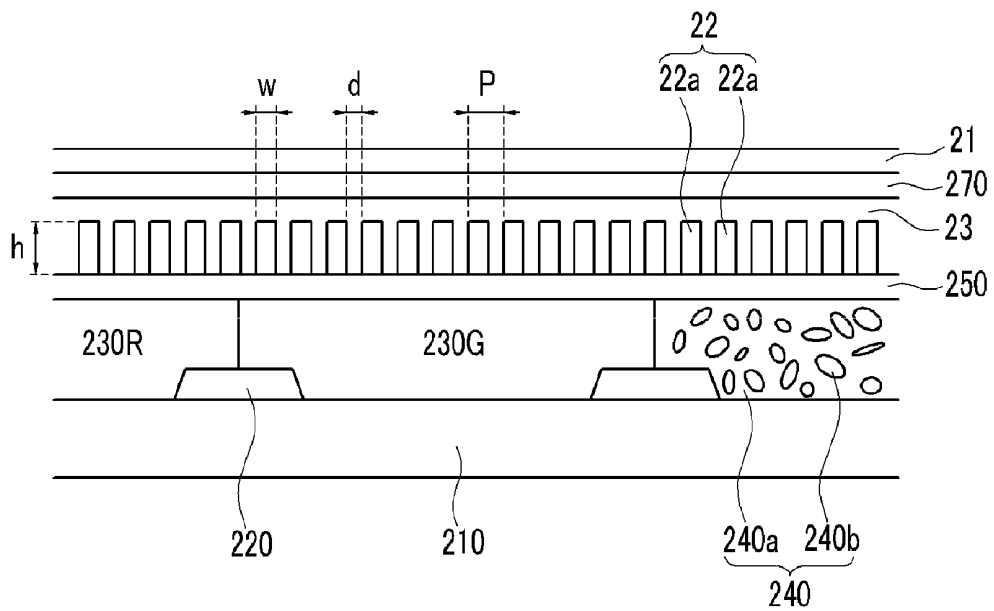
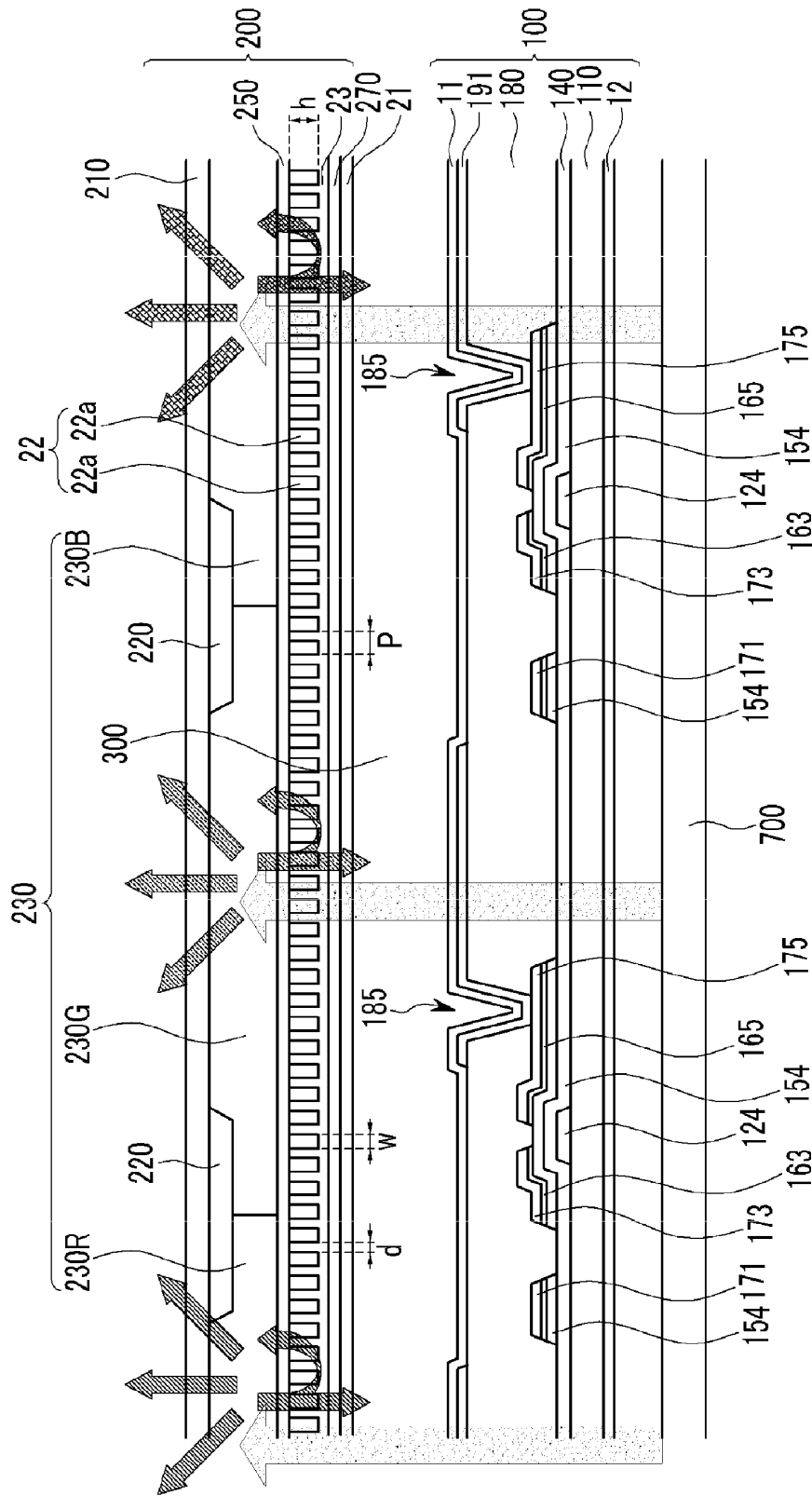

FIG. 16



LIQUID CRYSTAL DISPLAY HAVING LIGHT DIFFUSION LAYER

CROSS REFERENCE TO RELATED APPLICATION

This application claims priority from and the benefit of Korean Patent Application No. 10-2008-0096526, filed on Oct. 1, 2008, and Korean Patent Application No. 10-2009-0029496 filed on Apr. 6, 2009, which are hereby incorporated by reference for all purposes as if fully set forth herein.

BACKGROUND OF THE INVENTION

1. Field of the Invention

The present invention relates to a liquid crystal display.

2. Discussion of the Background

A liquid crystal display (LCD) is one of the most commonly used flat panel displays, and includes two substrates with electrodes formed thereon and a liquid crystal layer interposed between the two substrates. In the LCD, a voltage is applied to the electrodes to realign liquid crystal molecules of the liquid crystal layer to thereby regulate the transmittance of light passing through the liquid crystal layer.

Among LCDs, an LCD having a structure in which field generating electrodes are respectively formed on two display panels is widely used. Among the two display panels, a plurality of pixel electrodes and thin film transistors are arranged in a matrix format on one display panel (hereinafter, referred to as "a thin film transistor array panel"), and red, green, and blue color filters are formed on the other display panel with a common electrode covering the entire surface of the panel (hereinafter, referred to as "a common electrode panel").

However, such type of LCD may lose light when passing through the polarizers and the color filters. To reduce the light loss and make a more efficient LCD, a photo-luminescent liquid crystal display (PL-LCD) has been developed to have a color conversion material instead of color filters.

The PL-LCD uses a color conversion media (CCM) instead of the color filters. In the PL-LCD device, an ultraviolet (UV) light or a bluish light that is generated from a light source and controlled by a liquid crystal layer is irradiated onto a color conversion media layer so that a visible light is generated from the color conversion media layer, thereby displaying an image. The UV light and the bluish light have relatively short wavelengths.

However, the color conversion of red and green, and a difference of the blue transmitted light may not render uniform color depending on viewing angles, which may generate the viewing angle problem. The color conversion media layer in red, green, and blue may form a step, which may cause a problem in controlling the liquid crystal.

Also, the visible lights from the fluorescent layer in various directions, and scattered by molecules in the fluorescent layer decreases luminance, resolution, and contrast ratio of the PL-LCD.

SUMMARY OF THE INVENTION

The present invention provides an LCD with a color conversion media, to prevent a change of color uniformity according to viewing angle in a PL-LCD, and to improve luminance and resolution of the PL-LCD.

Additional features of the invention will be set forth in the description which follows, and in part will be apparent from the description, or may be learned by practice of the invention.

The present invention discloses a liquid crystal display including: a first substrate; a thin film transistor arranged on the first substrate; a pixel electrode connected to the thin film transistor; a second substrate facing the first substrate; a light diffusion layer comprising a color conversion media layer and a non-conversion layer arranged on the second substrate; a common electrode arranged on the second substrate; a liquid crystal layer disposed between the first substrate and the second substrate; and a backlight assembly to supply light to the first substrate and the second substrate.

The non-conversion layer may include a transparent polymer and a plurality of openings.

The openings may be smaller than about 40 μm .

The non-conversion layer may include a transparent polymer and a plurality of transparent beads.

The beads may be smaller than about 40 μm .

The backlight assembly may include a blue light emitting diode.

The color conversion media layer may include a red color conversion media layer and a green color conversion media layer.

The red color conversion media layer may include a red phosphor, wherein the red phosphor may include at least one material of (Ca, Sr, Ba)S, (Ca, Sr, Ba)₂Si₅N₈, CaAlSiN₃, CaMoO₄, and Eu₂Si₅N₈. The green color conversion media layer may include a green phosphor, wherein the green phosphor may include at least one material of yttrium aluminum garnet (YAG), (Ca, Sr, Ba)₂SiO₄, SrGa₂S₄, BAM, α -SiAlON, β -SiAlON, Ca₃Sc₂Si₃O₁₂, Tb₃Al₅O₁₂, BaSiO₄, CaAlSiON, and (Sr_{1-x}Ba_x)Si₂O₂N₂.

The color conversion media layer may include quantum dots.

The quantum dots may include a first portion and a second portion, the second portion enclosing the first portion, the first portion may include at least one material of an II-IV group semiconductor comprising ZnS, CdSe, or HgTe, an IV-VI group semiconductor comprising PbS, PbSe, or PbTe, and an III-V group semiconductor comprising AlN, GaP, or InAs, and the second portion may include at least one material of an II-IV group semiconductor comprising ZnS, CdSe, or HgTe, an IV-VI group semiconductor comprising PbS, PbSe, or PbTe, and an III-V group semiconductor comprising GaN, GaP, or InAs.

The liquid crystal display further includes a lower polarizer arranged on a rear surface of the first substrate; and an upper polarizer arranged on the second substrate layer.

The upper polarizer may be arranged between the light diffusion layer and the liquid crystal layer. The upper polarizer may be arranged between the light diffusion layer and the second substrate.

The liquid crystal display further includes a passivation layer arranged on the light diffusion layer.

The upper polarizer may include a reflecting polarizer layer reflecting light scattered in the color conversion media layer toward the color conversion media layer.

The reflecting polarizer may include a plurality of wire grids.

The wire grid may be stripe shape.

A period of the wire grid may be less than about 200 nm.

The present invention also discloses a liquid crystal display including: a first substrate; a thin film transistor arranged on the first substrate; a pixel electrode connected to the thin film transistor; a backlight assembly to supply a first light comprising a first wavelength to the first substrate; a second substrate facing the first substrate; a color conversion media layer arranged on the second substrate, the color conversion media layer converts the first light into a second light comprising a

second wavelength and scatters the second light; a reflecting polarizer arranged on the color conversion media layer, the reflecting polarizer reflects the second light toward the color conversion media layer; a common electrode arranged on the reflecting polarizer; and a liquid crystal layer disposed between the first substrate and the second substrate.

The reflecting polarizer may comprise a plurality of wire grids.

The wire grid may be stripe shape.

A period of the wire grid may be less than about 200 nm.

The wire grid may include at least one of aluminum (Al), molybdenum (Mo), tantalum (Ta), titanium (Ti), tungsten (W), chromium (Cr) or silver (Ag).

The first light including the first wavelength may be blue light.

The first wavelength may include in the range of about 430 nm–480 nm.

The color conversion media layer may include a red color conversion media layer and a green color conversion media layer.

The liquid crystal display further includes a non-conversion layer disposed between the second substrate and the reflecting polarizer.

The non-conversion layer may include a plurality of openings and a transparent polymer.

The red color conversion media layer may include a red phosphor and the green color conversion media layer may include a green phosphor.

The color conversion media layer may include quantum dots.

The first light including the first wavelength is ultra violet light.

The first wavelength may include in the range of about 200 nm–410 nm.

The color conversion media layer may include a red color conversion media layer, a green color conversion media layer and a blue color conversion media layer.

The liquid crystal display further includes a non-conversion layer disposed between the second substrate and the reflecting polarizer.

The non-conversion layer may include a plurality of openings and a transparent polymer.

The red color conversion media layer may include a red phosphor and the green color conversion media layer may include a green phosphor.

The color conversion media layer may include quantum dots.

The first light including the first wavelength may be ultra violet light.

The first wavelength may include in the range of about 200 nm–410 nm.

The color conversion media layer may include a red color conversion media layer, a green color conversion media layer and a blue color conversion media layer.

The red color conversion media layer may include a red phosphor, the green color conversion media layer may include a green phosphor and the blue color conversion media layer is include a blue phosphor.

The color conversion media layer may include quantum dots.

The upper polarizer may be arranged between the color conversion media layer and the liquid crystal layer. The upper polarizer is arranged between the color conversion media layer and the second substrate.

The liquid crystal display further includes a passivation layer arranged on the color conversion media layer.

It is to be understood that both the foregoing general description and the following detailed description are exemplary and explanatory and are intended to provide further explanation of the invention as claimed.

BRIEF DESCRIPTION OF THE DRAWINGS

The accompanying drawings, which are included to provide a further understanding of the invention and are incorporated in and constitute a part of this specification, illustrate embodiments of the invention, and together with the description serve to explain the principles of the invention.

FIG. 1 is a layout view of a liquid crystal display according to an embodiment of the present invention.

FIG. 2 is a cross-sectional view of the liquid crystal display shown in FIG. 1 taken along the line II-II'.

FIG. 3 is a cross-sectional view of the liquid crystal display shown in FIG. 1 taken along the line III-III'.

FIG. 4, FIG. 5, FIG. 6, FIG. 7, and FIG. 8 are cross-sectional views sequentially showing a manufacturing method of a common electrode panel according to an embodiment of the present invention.

FIG. 9 is a cross-sectional view of a liquid crystal display according to another embodiment of the present invention.

FIG. 10 is a layout view of a liquid crystal display according to another embodiment of the present invention.

FIG. 11 is a cross-sectional view of the liquid crystal display shown in FIG. 10 taken along the line IV-IV'.

FIG. 12, FIG. 13, FIG. 14, and FIG. 15 are cross-sectional views sequentially showing a manufacturing method of a common electrode panel according to another embodiment of the present invention.

FIG. 16 is a cross-sectional view of the liquid crystal display shown in FIG. 10 taken along the line IV-IV'.

DETAILED DESCRIPTION OF THE ILLUSTRATED EMBODIMENTS

The invention is described more fully hereinafter with reference to the accompanying drawings, in which embodiments of the invention are shown. This invention may, however, be embodied in many different forms and should not be construed as limited to the embodiments set forth herein. Rather, these embodiments are provided so that this disclosure is thorough, and will fully convey the scope of the invention to those skilled in the art. In the drawings, the size and relative sizes of layers and regions may be exaggerated for clarity. Like reference numerals in the drawings denote like elements.

It will be understood that when an element or layer is referred to as being “on” or “connected to” another element or layer, it can be directly on or directly connected to the other element or layer, or intervening elements or layers may be present. In contrast, when an element is referred to as being “directly on” or “directly connected to” another element or layer, there are no intervening elements or layers present.

A liquid crystal display according to the an embodiment of the present invention will be described below with reference to FIG. 1, FIG. 2, and FIG. 3.

FIG. 1 is a layout view of a liquid crystal display according to an embodiment of the present invention, FIG. 2 is a cross-sectional view of the liquid crystal display shown in FIG. 1 taken along the line II-II', and FIG. 3 is a cross-sectional view of the liquid crystal display shown in FIG. 1 taken along the line III-III'.

As shown in FIG. 1, FIG. 2, and FIG. 3, a liquid crystal display according to the first exemplary embodiment of the

present invention includes a thin film transistor array panel **100** and a common electrode panel **200** facing each other, and a liquid crystal layer **3** interposed between the two display panels **100** and **200**. Also, a backlight assembly **700** for supplying light to the two display panels **100** and **200** is included.

The backlight assembly irradiates a blue light and may include a blue light emit diode (LED). A wavelength of the blue light is about 430 μm to 480 μm .

Firstly, the thin film transistor array panel **100** will be described.

The thin film transistor array panel **100** includes a plurality of gate lines **121** formed on a lower substrate **110** made of an insulating material such as glass or plastic. A gate insulating layer **140**, a plurality of semiconductors **154**, a plurality of ohmic contacts **163** and **165**, a plurality of data lines **171** and a plurality of drain electrodes **175** are sequentially formed thereon.

The gate lines **121** transmit gate signals and extend in a transverse direction. Each of the gate lines **121** includes a plurality of gate electrodes **124** protruding upward.

The data lines **171** transmit data signals and extend in a longitudinal direction, thereby crossing the gate lines **121**. Each data line **171** includes a plurality of source electrodes **173** extending toward the gate electrodes **124**. The drain electrodes **175** are separated from the data lines **171** and are opposite to the source electrodes **173** with respect to the gate electrodes **124**.

The semiconductor **154** is disposed on the gate electrode **124** but separated from it by gate insulating layer **140**. The ohmic contacts **163** and **165** are disposed between the semiconductor **154**, and the data line **171** and drain electrode **175** respectively, thereby reducing resistance therebetween.

A gate electrode **124**, a source electrode **173**, and a drain electrode **175** form a thin film transistor (TFT) along with the semiconductor **154**. A channel of the thin film transistor is formed in the semiconductor **154** between the source electrode **173** and the drain electrode **175**.

A passivation layer **180** is formed on the gate insulating layer **140**, the data line **171**, and the drain electrode **175**.

A pixel electrode **191** is formed on the passivation layer **180**. The pixel electrode **191** may be made of a transparent conductive material such as indium tin oxide (ITO) or indium zinc oxide (IZO), or a reflective metal such as aluminum or a silver alloy, and is connected to the drain electrode **175** through the contact hole **185**.

A lower alignment layer **11** for aligning liquid crystal molecules is formed on the pixel electrode **191**, and a lower polarizer **12** is formed on a rear surface of the first substrate **110**.

Next, the common electrode panel **200** will be described.

A plurality of light blocking members **220** referred to as a black matrix are formed on an upper substrate **210** made of an insulating material such as glass or plastic.

A light diffusion layer **400** is formed on the upper substrate **210**. The diffusion layer **400** includes a color conversion media layer **230** and a non-conversion layer **240**.

The color conversion media layer **230** includes a red color conversion media layer **230R** and a green color conversion media layer **230G**.

The red color conversion media layer **230R** converts blue light supplied from the backlight assembly **700** including a blue light emitting diode (LED) into red light. The red color conversion media layer **230R** is made of red phosphors, and at least one material of (Ca, Sr, Ba)S, (Ca, Sr, Ba)₂Si₅N₈, CaAlSiN₃, CaMoO₄, and Eu₂Si₅N₈ may be used as the red phosphors.

The green color conversion media layer **230G** converts the blue light supplied from the backlight assembly **700** including a blue light emitting diode (LED) into green light. The green color conversion media layer **230G** is made of green phosphors, and at least one material of yttrium aluminum garnet (YAG), (Ca, Sr, Ba)₂SiO₄, SrGa₂S₄, BAM, α -SiAlON, β -SiAlON, Ca₃Sc₂Si₃O₁₂, Tb₃Al₅O₁₂, BaSiO₄, CaAlSiON, and (Sr_{1-x}Ba_x)Si₂O₂N₂ may be used as the green phosphors.

Also, the red color conversion media layer **230R** and the green color conversion media layer **230G** may be made of quantum dots of which the color is changed according to the size.

The quantum dots include a core and a shell enclosing the core, and the core is made of at least one material of a II-IV group semiconductor including ZnS, ZnSe, ZnTe, CdS, CdSe, CdTe, HgS, HgSe, or HgTe, a IV-VI group semiconductor including PbS, PbSe, or PbTe, and a III-V group semiconductor including AlN, AlP, AlAs, AlSb, GaN, GaP, GaAs, GaSb, InN, InP, InAs, or InSb.

Also, the shell is made of at least one material of a II-IV group semiconductor including ZnS, ZnSe, ZnTe, CdS, CdSe, CdTe, HgS, HgSe, or HgTe, a IV-VI group semiconductor including PbS, PbSe, or PbTe, and a III-V group semiconductor including GaN, GaP, GaAs, GaSb, InN, InP, InAs, or InSb.

The non-conversion layer **240** transmits blue light supplied from the backlight assembly **700** including a blue light emitting diode (LED). The non-conversion layer is made of a transparent polymer **240a** including a plurality of openings **240b**. The size of the openings **240b** may be less than 40 μm . The blue light supplied from the backlight assembly **700** including a blue light emitting diode (LED) is diffused by the openings **240b** of the non-conversion layer **240**.

Also, the non-conversion layer **240** may be made of a transparent polymer including beads (not shown) instead of the openings **240b**. Here, the size of the beads may be also less than 40 μm .

As described above, the red color conversion media layer **230R** and the green color conversion media layer **230G** reduces the light loss, by using phosphors that generate red light and green light. This may cause light density difference between red and green lights and blue light. Thus, the non-conversion layer **240** includes the transparent polymer **240a** and the openings (or the beads—not shown) **240b** to reduce or eliminate the step between the red color conversion media layer **230R** and the green color conversion media layer **230G**, and the non-conversion layer **240**. Further, such non-conversion layer **240** diffuses the blue light as directly transmitted from the blue LED and thereby may solve the viewing angle problem.

An upper polarizer **22** is formed on the red color conversion media layer **230R**, the green color conversion media layer **230G**, and the non-conversion layer **240**.

A common electrode **270** is formed on the upper polarizer **22**, and an upper alignment layer **21** is formed on the common electrode **270**.

Next, how to manufacture the common electrode panel **200** according to an embodiment of the present invention will be described with reference to FIG. 4, FIG. 5, FIG. 6, FIG. 7, and FIG. 8.

FIG. 4, FIG. 5, FIG. 6, FIG. 7, and FIG. 8 are cross-sectional views sequentially showing manufacturing steps of a common electrode panel according to an embodiment of the present invention.

First, as shown in FIG. 4, a light blocking member **220** is formed on the insulation substrate **210**.

Next, as shown in FIG. 5, a mixed material including a plurality of photosensitive film resin particles **241b** and a transparent polymer **241a** is coated on a substrate **210**, and ultraviolet rays are irradiated on only a blue pixel portion by using a mask **30** covering red and green pixel portions to harden the mixed material of the photosensitive film resin particles **241a** and the transparent polymer **241a**. Here, the size of the photosensitive film resin particles **241b** may be less than 40 μm .

Next, as shown in FIG. 6, the mixed material of the photosensitive film resin particles **241b** and the transparent polymer **241a** corresponding to the red and green pixel portions is developed and removed. The non-conversion layer **240** is completed to have transparent polymer **240a** with a plurality of openings **240b**, by melting the photosensitive film resin particles **241b** with a solvent to form a plurality of openings **240b**.

Alternatively, a mixed material including a plurality of transparent beads with a size of less than 40 μm and a transparent polymer may be coated to form the non-conversion layer **240**, and ultraviolet rays are irradiated only to the blue pixel portion by using a mask **30** covering the red and green pixel portions to harden the mixed material of the transparent beads and the transparent polymer **240a** of the blue pixel portions. Next, the mixed material of the transparent beads and the transparent polymer **240a** corresponding to the red and green pixels is developed and removed.

Then, as shown in FIG. 7, a red color conversion media layer **230R** and a green color conversion media layer **230G** are formed. The red color conversion media layer **230R** may include at least one material of (Ca, Sr, Ba)S, (Ca, Sr, Ba)₂Si₅N₈, CaAlSiN₃, CaMoO₄, or Eu₂Si₅N₈, and the green color conversion media layer **230G** may include at least one material of yttrium aluminum garnet (YAG), (Ca, Sr, Ba)₂SiO₄, SrGa₂S₄, BAM, α -SiAlON, β -SiAlON, Ca₃Sc₂Si₃O₁₂, Tb₃Al₅O₁₂, BaSiO₄, CaAlSiON, or (Sr_{1-x}Ba_x)Si₂O₂N₂.

Also, the red color conversion media layer **230R** and the green color conversion media layer **230G** may include quantum dots of which the color is changed according to the size.

The quantum dots include a core and a shell enclosing the core, and the core is made of at least one material of an II-IV group semiconductor including ZnS, ZnSe, ZnTe, CdS, CdSe, CdTe, HgS, HgSe, or HgTe, an IV-VI group semiconductor including PbS, PbSe, or PbTe, and an III-V group semiconductor including AlN, AlP, AlAs, AlSb, GaN, GaP, GaAs, GaSb, InN, InP, InAs, or InSb.

Also, the shell is made of at least one material of an II-IV group semiconductor including ZnS, ZnSe, ZnTe, CdS, CdSe, CdTe, HgS, HgSe, or HgTe, an IV-VI group semiconductor including PbS, PbSe, or PbTe, and an III-V group semiconductor including GaN, GaP, GaAs, GaSb, InN, InP, InAs, or InSb.

Next, as shown in FIG. 8, an upper polarizer **22**, a common electrode **270**, and an upper alignment layer **21** are sequentially formed on the red color conversion media layer **230R**, the green color conversion media layer **230G**, and the non-conversion layer **240**.

A liquid crystal display according to another embodiment of the present invention will be described with reference to FIG. 9.

FIG. 9 is a cross-sectional view of a liquid crystal display according to another embodiment of the present invention.

As shown in FIG. 9, a common electrode **270** is formed on an insulation substrate **210**, and an upper alignment layer **21** is formed on the common electrode **270**.

An upper polarizer **22** is formed on the rear surface of the insulation substrate **210**, and a light blocking member **220** is formed on the upper polarizer **22**. A diffusion layer **400** is formed on the upper polarizer **22** and the light blocking member **220**. The diffusion layer **400** includes a color conversion media layer **230** and a non-conversion layer **240**.

The color conversion media layer **230** includes a red color conversion media layer **230R**, and a green color conversion media layer **230G**.

A second passivation layer **280** for protecting the color conversion media layer **230** and the non-conversion layer **240** is formed on the color conversion media layer **230** and the non-conversion layer **240**.

A liquid crystal display according to another embodiment of the present invention will be described with reference to FIG. 10 and FIG. 11.

FIG. 10 is a layout view of a liquid crystal display according to another embodiment of the present invention, FIG. 11 is a cross-sectional view of the liquid crystal display shown in FIG. 10 taken along the line IV-IV'.

As shown in FIG. 10 and FIG. 11, a liquid crystal display according to another embodiment of the present invention includes a thin film transistor array panel **100**, a common electrode panel **200** facing each other, a liquid crystal layer **3** interposed between the two display panels **100** and **200**, and a backlight assembly **700** for supplying light to the two display panels **100** and **200**. Also, the common electrode panel **200** includes a reflecting polarizer **22** including the plurality of wire grid **22a**.

The backlight assembly irradiates a blue light and may include a blue light emit diode (LED). A wavelength of the blue light is about 430 μm to about 480 μm .

First, the common electrode panel **200** will be described.

A plurality of light blocking members **220** referred to as a black matrix are formed on an upper substrate **210** made of an insulating material such as glass or plastic.

A color conversion media layer **230** including a red color conversion media layer **230R** and a green color conversion media layer **230G** is formed on the upper substrate **210**, and a non-conversion layer **240** are formed on the upper substrate **210**.

The backlight assembly **700** includes a blue light emitting diode (LED) and provided blue lights with a wavelength of about 430 μm to 480 μm . The red color conversion media layer **230R** converts the blue light from the backlight assembly **700** into red light. The red color conversion media layer **230R** is made of red phosphors. The red phosphors may include at least one material of (Ca, Sr, Ba)S, (Ca, Sr, Ba)₂Si₅N₈, CaAlSiN₃, CaMoO₄, and Eu₂Si₅N₈.

The green color conversion media layer **230G** converts the blue light from the backlight assembly **700** into green light. The green color conversion media layer **230G** is made of green phosphors. The green phosphors may include at least one material of yttrium aluminum garnet (YAG), (Ca, Sr, Ba)₂SiO₄, SrGa₂S₄, BAM, α -SiAlON, β -SiAlON, Ca₃Sc₂Si₃O₁₂, Tb₃Al₅O₁₂, BaSiO₄, CaAlSiON, and (Sr_{1-x}Ba_x)Si₂O₂N₂.

Also, the red color conversion media layer **230R** and the green color conversion media layer **230G** may be made of quantum dots of which the color may change according to its size.

The quantum dots include a core and a shell enclosing the core, and the core is made of at least one material of a II-IV group semiconductor including ZnS, ZnSe, ZnTe, CdS, CdSe, CdTe, HgS, HgSe, or HgTe, a IV-VI group semiconductor including PbS, PbSe, or PbTe, and a III-V group semi-

conductor including AlN, AlP, AlAs, AlSb, GaN, GaP, GaAs, GaSb, InN, InP, InAs, or InSb.

Also, the shell is made of at least one material of a II-IV group semiconductor including ZnS, ZnSe, ZnTe, CdS, CdSe, CdTe, HgS, HgSe, or HgTe, a IV-VI group semiconductor including PbS, PbSe, or PbTe, and a III-V group semiconductor including GaN, GaP, GaAs, GaSb, InN, InP, InAs, or InSb.

A visible light including the red light or the green light generated from the color conversion media layer 230 is scattered in various directions, and a portion of the visible light is irradiated onto the backlight assembly 700.

The non-conversion layer 240 is made of a transparent polymer 240a including a plurality of openings 240b. The openings 240b may be smaller than 40 μm . The blue light from the backlight assembly 700 is diffused by the openings 240b of the non-conversion layer 240.

Also, the non-conversion layer 240 may be made of a transparent polymer 240a including beads (not shown) instead of the openings 240b. Here, the beads may be also smaller than 40 μm in diameter.

Also, the non-conversion layer 240 may only include a transparent polymer 240a and none of openings 240b. Also, the non-conversion layer 240 may not be included.

Next, a planar layer 250 is formed on the color conversion media layer 230 and the non-conversion layer 240.

The planar layer 250 may provide a flat surface for a step formed on the color conversion layer 230 and the non-conversion layer 240. The planar layer 250 may include one of acryl resin, polyamide resin or polycarbonate resin. Also, the planar layer may be omitted.

A reflecting polarizer 22 is formed on the planar layer 250.

The reflecting polarizer 22 may include a plurality of wire grids 22a. Here, The wire grid 22a is stripe shape and is made of a conductive metal, for example, aluminum (Al), molybdenum (Mo), tantalum (Ta), titanium (Ti), tungsten (W), chromium (Cr) and silver (Ag).

The plurality of wire grid 22a include an interval (d), a width (w), a height (h) and a period (P). The period (P) of the wire grid 22a is a sum of the interval (d) and the width (w) of the wire grid 22a. The period (P) of the wire grid 22a is smaller than a wavelength of an incident light. The period (P) of the wire grid 22a may be less than about 200 nm and the height of the wire grid 22a may be not less than about 100 nm. The interval (d), the width (w), the height (h) and the period (P) may be formed in a various size or shape according to optical characteristics demanded in certain PL-LCDs.

An insulating layer 23 is formed on the reflecting polarizer 22.

The insulating layer 23 covers the reflecting polarizer 22 and provides a flat surface. The insulating layer 23 may include one of acryl resin, polyamide resin or polycarbonate resin.

A common electrode 270 is formed on insulating layer 23, and an upper alignment layer 21 is formed on the common electrode 270.

Next, a light path supplied from the backlight assembly 700 and scattered in the color conversion media layer 230 will be described below with reference to FIG. 11.

The light supplied from the backlight assembly 700 is polarized by the lower polarizer 12 and enters into a rear surface of the thin film transistor array panel 100. A direction of the polarized light through the pixel electrode 191 is controlled by the liquid crystal layer 3.

The polarized light through the liquid crystal layer 3 enters into the reflecting polarizer 22. Here, a polarized direction of light through the reflecting polarizer 22 corresponds to a

polarized direction of the light through the liquid crystal layer 3. The polarized light through the reflecting polarizer 22 enters into the color conversion media layer 230 and is converted into a visible light, and is scattered in various directions. A portion of the visible light enters into the upper substrate 210 and a portion of the visible light enters into the backlight assembly 700. Also, the visible light scattered into the color conversion media layer does not include the polarized light.

The reflecting polarizer 22 reflects a portion of the visible light entering to the backlight assembly 700 toward the color conversion media layer 230. For example, when the reflecting polarizer 22 includes the plurality of wire grid 22a the reflecting polarizer 22 may reflect S wave toward the color conversion media layer 230. Therefore, the reflecting polarizer 22 improves light efficiency.

Also, a blue light entered to the non-conversion layer 240 through the reflecting polarizer 22 is diffused by the openings 240b and passes the upper substrate 210.

Next, a manufacturing method of the common electrode panel 200 according to the another embodiment of the present invention will be described with reference to FIG. 12, FIG. 13, FIG. 14, and FIG. 15.

FIG. 12, FIG. 13, FIG. 14, and FIG. 15 are cross-sectional views sequentially showing manufacturing steps of a common electrode panel according to another embodiment of the present invention.

First, as shown in FIG. 12, a light blocking member 220, a red color conversion media layer 230R, a green color conversion media layer 240G and a non-conversion layer 240 are formed on the insulation substrate 210.

Next, as shown in FIG. 13, a planar layer 250 is formed on the red color conversion media layer 230R, the green color conversion media layer 240G and the non-conversion layer 240. Also, a conductive metal layer 310 is formed on the planar layer 250. The conductive metal layer 310 may include one of aluminum (Al), molybdenum (Mo), tantalum (Ta), titanium (Ti), tungsten (W), chromium (Cr) or silver (Ag).

Next, a photo-resist layer 311 is formed on the conductive metal layer 310. The photo-resist layer 311 is exposed through a mask 300 including a pattern corresponding to a plurality of wire grids 22a.

Next, as shown in FIG. 14, a photo-resist pattern 31 is formed by developing the exposed photo-resist layer 311. The plurality of wire grids 22a is formed by etching the photo-resist pattern 31.

Next, as shown in FIG. 15, after removing remaining photo-resist pattern 31, an insulation layer 23, a common electrode 270 and an upper alignment layer 21 is formed sequentially.

The period (P) of the wire grid 22a may be less than about 200 nm. Also, the wire grid 22a according to another embodiment of the present invention is stripe shape. However, the reflecting layer 22 may be formed in a various size or shape.

Next, a liquid crystal display according to another embodiment of the present invention will be described with reference to FIG. 16.

FIG. 16 is a cross-sectional view of the liquid crystal display shown in FIG. 10 taken along the line IV-IV'.

As shown in FIG. 10 and FIG. 16, a liquid crystal display according to another embodiment of the present invention includes a thin film transistor array panel 100, a common electrode panel 200 facing each other, a liquid crystal layer 3 interposed between the two display panels 100 and 200 and a backlight assembly 700 for supplying light to the two display panels 100 and 200.

The backlight assembly **700** according to another embodiment of the present invention irradiates an ultra violet (UV) light. The wavelength of the UV light may range from about 200 nm to about 410 nm. Also, the backlight assembly **700** may irradiate a near UV light. The wavelength of the near UV light may range from about 380 nm to about 410 nm.

The period (P) of the wire grid **22a** needs to be smaller than a wavelength of an incident light. The period (P) of the wire grid **22a** may be less than about 200 nm.

Also, a color conversion media layer **230** of a liquid crystal display according to another embodiment of the present invention further includes a blue color conversion media layer **230B**.

The blue color conversion media layer **230B** converts UV light from the backlight assembly **700** into blue light. The blue color conversion media layer **230B** is made blue phosphors, and $3(\text{Ba}, \text{Mg}, \text{Eu}, \text{Mn})\text{O} \cdot 8 \text{Al}_2\text{O}_3$ may be used as the blue. The red color conversion media layer **230R** is made of red phosphors, and at least one material of $(\text{Ca}, \text{Sr}, \text{Ba})\text{S}$, $(\text{Ca}, \text{Sr}, \text{Ba})_2\text{Si}_5\text{N}_8$, CaAlSiN_3 , CaMoO_4 , and $\text{Eu}_2\text{Si}_5\text{N}_8$ may be used as the red phosphors. The green color conversion media layer **230G** is made of green phosphors, and at least one material of yttrium aluminum garnet (YAG), $(\text{Ca}, \text{Sr}, \text{Ba})_2\text{SiO}_4$, SrGa_2S_4 , BAM, $\alpha\text{-SiAlON}$, $\beta\text{-SiAlON}$, $\text{Ca}_3\text{Sc}_2\text{Si}_3\text{O}_{12}$, $\text{Tb}_3\text{Al}_5\text{O}_{12}$, BaSiO_4 , CaAlSiON , and $(\text{Sr}_{1-x}\text{Ba}_x)\text{Si}_2\text{O}_2\text{N}_2$ may be used as the green phosphors.

Also, the blue color conversion media layer **230B** may be made of quantum dots of which the color is changed according to the size.

The quantum dots include a core and a shell enclosing the core, and the core is made of at least one material of a II-IV group semiconductor including ZnS, ZnSe, ZnTe, CdS, CdSe, CdTe, HgS, HgSe, or HgTe, a IV-VI group semiconductor including PbS, PbSe, or PbTe, and a III-V group semiconductor including AlN, AlP, AlAs, AlSb, GaN, GaP, GaAs, GaSb, InN, InP, InAs, or InSb.

Also, the shell is made of at least one material of a II-IV group semiconductor including ZnS, ZnSe, ZnTe, CdS, CdSe, CdTe, HgS, HgSe, or HgTe, a IV-VI group semiconductor including PbS, PbSe, or PbTe, and a III-V group semiconductor including GaN, GaP, GaAs, GaSb, InN, InP, InAs, or InSb.

The reflecting polarizer **22** transmits the UV light through a lower polarizer **12** and a liquid crystal layer **300**. The UV light through the reflecting polarizer **22** is converted and scattered into a visible light in a red color conversion media layer **230R**, a green color conversion media layer **230G** and the blue green color conversion media layer **230B**.

The reflecting polarizer **22** reflects toward the color conversion media layer **230** a portion of the visible light entering back to the backlight assembly **700**. Therefore, the reflecting polarizer **22** improves light efficiency.

It will be apparent to those skilled in the art that various modifications and variation can be made in the present invention without departing from the spirit or scope of the invention. Thus, it is intended that the present invention cover the modifications and variations of this invention provided they come within the scope of the appended claims and their equivalents.

What is claimed is:

1. A liquid crystal display, comprising:
 - a first substrate;
 - a thin film transistor arranged on the first substrate;
 - a pixel electrode connected to the thin film transistor;
 - a second substrate facing the first substrate;

a light diffusion layer comprising a color conversion media layer and a non-conversion layer arranged on the second substrate;

a common electrode arranged on the second substrate;

a liquid crystal layer disposed between the first substrate and the second substrate; and a backlight assembly to supply light to the first substrate and the second substrate.

2. The liquid crystal display of claim 1, wherein the non-conversion layer comprises a transparent polymer and a plurality of openings.

3. The liquid crystal display of claim 2, wherein the plurality of openings are smaller than about 40 μm .

4. The liquid crystal display of claim 1, wherein the non-conversion layer comprises a transparent polymer and a plurality of transparent beads.

5. The liquid crystal display of claim 4, wherein the plurality of transparent beads are smaller than about 40 μm .

6. The liquid crystal display of claim 1, wherein the backlight assembly comprises a blue light emitting diode.

7. The liquid crystal display of claim 6, wherein the color conversion media layer comprises a red color conversion media layer and a green color conversion media layer.

8. The liquid crystal display of claim 7, wherein the red color conversion media layer comprises a red phosphor, wherein the red phosphor comprises at least one material of $(\text{Ca}, \text{Sr}, \text{Ba})\text{S}$, $(\text{Ca}, \text{Sr}, \text{Ba})_2\text{Si}_5\text{N}_8$, CaAlSiN_3 , CaMoO_4 , and $\text{Eu}_2\text{Si}_5\text{N}_8$, and

wherein the green color conversion media layer comprises a green phosphor,

wherein the green phosphor comprises at least one material of yttrium aluminum garnet (YAG), $(\text{Ca}, \text{Sr}, \text{Ba})_2\text{SiO}_4$, SrGa_2S_4 , BAM, $\alpha\text{-SiAlON}$, $\beta\text{-SiAlON}$, $\text{Ca}_3\text{Sc}_2\text{Si}_3\text{O}_{12}$, $\text{Tb}_3\text{Al}_5\text{O}_{12}$, BaSiO_4 , CaAlSiON , and $(\text{Sr}_{1-x}\text{Ba}_x)\text{Si}_2\text{O}_2\text{N}_2$.

9. The liquid crystal display of claim 1, wherein the color conversion media layer comprises quantum dots.

10. The liquid crystal display of claim 9, wherein the quantum dots comprise a first portion and a second portion, the second portion enclosing the first portion, the first portion comprises at least one material of an II-IV group semiconductor comprising ZnS, CdSe, or HgTe, an IV-VI group semiconductor comprising PbS, PbSe, or PbTe, and an III-V group semiconductor comprising AlN, GaP, or InAs, and

the second portion comprises at least one material of an II-IV group semiconductor comprising ZnS, CdSe, or HgTe, an IV-VI group semiconductor comprising PbS, PbSe, or PbTe, and an III-V group semiconductor comprising GaN, GaP, or InAs.

11. The liquid crystal display of claim 1, further comprising:

a lower polarizer arranged on a rear surface of the first substrate; and

an upper polarizer arranged on the second substrate.

12. The liquid crystal display of claim 11, wherein the upper polarizer is arranged between the light diffusion layer and the liquid crystal layer.

13. The liquid crystal display of claim 12, wherein the upper polarizer is arranged between the light diffusion layer and the second substrate.

14. The liquid crystal display of claim 13, further comprising a passivation layer arranged on the light diffusion layer.

15. The liquid crystal display of claim 11, wherein the upper polarizer comprises a reflecting polarizer layer reflecting light scattered in the color conversion media layer toward the color conversion media layer.

13

- 16. The liquid crystal display of claim 15, wherein the reflecting polarizer comprises a plurality of wire grids.
- 17. The liquid crystal display of claim 16, wherein the plurality of wire grids have a stripe shape.
- 18. The liquid crystal display of claim 17, wherein a period of the wire grid is less than about 200 nm.
- 19. A liquid crystal display, comprising:
 - a first substrate;
 - a thin film transistor arranged on the first substrate;
 - a pixel electrode connected to the thin film transistor;
 - a backlight assembly to supply a first light comprising a first wavelength to the first substrate;
 - a second substrate facing the first substrate;
 - a color conversion media layer arranged on the second substrate, the color conversion media layer converts the first light into a second light comprising a second wavelength and scatters the second light;
 - a reflecting polarizer arranged on the color conversion media layer, the reflecting polarizer reflects the second light toward the color conversion media layer;
 - a common electrode arranged on the reflecting polarizer; and
 - a liquid crystal layer disposed between the first substrate and the second substrate.
- 20. The liquid crystal display of claim 19, wherein the reflecting polarizer comprises a plurality of wire grids.
- 21. The liquid crystal display of claim 20, wherein the wire grid is stripe shape.
- 22. The liquid crystal display of claim 21, wherein a period of the wire grid is less than about 200 nm.
- 23. The liquid crystal display of claim 21, wherein the wire grid comprises at least one of aluminum (Al), molybdenum (Mo), tantalum (Ta), titanium (Ti), tungsten (W), chromium (Cr) or silver (Ag).
- 24. The liquid crystal display of claim 19, wherein the first light comprising the first wavelength is blue light.
- 25. The liquid crystal display of claim 24, wherein the first wavelength comprises in the range of about 430 nm~480 nm.

14

- 26. The liquid crystal display of claim 24, wherein the color conversion media layer comprises a red color conversion media layer and a green color conversion media layer.
- 27. The liquid crystal display of claim 26, further comprising a non-conversion layer disposed between the second substrate and the reflecting polarizer.
- 28. The liquid crystal display of claim 27, wherein the non-conversion layer comprise a plurality of openings and a transparent polymer.
- 29. The liquid crystal display of claim 26, wherein the red color conversion media layer comprises a red phosphor and the green color conversion media layer comprises a green phosphor.
- 30. The liquid crystal display of claim 24, wherein the color conversion media layer comprises quantum dots.
- 31. The liquid crystal display of claim 19, wherein the first light comprising the first wavelength is ultra violet light.
- 32. The liquid crystal display of claim 31, wherein the first wavelength comprises in the range of about 200 nm~410 nm.
- 33. The liquid crystal display of claim 31, wherein the color conversion media layer comprises a red color conversion media layer, a green color conversion media layer and a blue color conversion media layer.
- 34. The liquid crystal display of claim 33, wherein the red color conversion media layer comprises a red phosphor, the green color conversion media layer comprises a green phosphor and the blue color conversion media layer comprises a blue phosphor.
- 35. The liquid crystal display of claim 31, wherein the color conversion media layer comprises quantum dots.
- 36. The liquid crystal display of claim 19, wherein the upper polarizer is arranged between the color conversion media layer and the liquid crystal layer.
- 37. The liquid crystal display of claim 36, wherein the upper polarizer is arranged between the color conversion media layer and the second substrate.
- 38. The liquid crystal display of claim 37, wherein a passivation layer is arranged on the color conversion media layer.

* * * * *

专利名称(译)	具有光扩散层的液晶显示器		
公开(公告)号	US8294848	公开(公告)日	2012-10-23
申请号	US12/542232	申请日	2009-08-17
[标]申请(专利权)人(译)	三星电子株式会社		
申请(专利权)人(译)	SAMSUNG ELECTRONICS CO. , LTD.		
当前申请(专利权)人(译)	三星DISPLAY CO. , LTD.		
[标]发明人	CHO DON CHAN PARK JAE BYUNG BYUN JIN SEOB PARK HAE IL		
发明人	CHO, DON-CHAN PARK, JAE-BYUNG BYUN, JIN-SEOB PARK, HAE-IL		
IPC分类号	G02F1/1335		
CPC分类号	G02F1/133617 G02F1/133536 G02F2001/01791 G02F2001/133614 G02F2001/133616 G02F2203/34		
优先权	1020090029496 2009-04-06 KR 1020080096526 2008-10-01 KR		
其他公开文献	US20100079704A1		
外部链接	Espacenet USPTO		

摘要(译)

其中，液晶显示器包括：光漫射层，包括颜色转换介质层和布置在第二基板上的非转换层；以及背光组件，用于向第一基板和第二基板提供光。背光组件提供各种波长的光，包括蓝光或紫外线。通过液晶层的蓝色权利进入颜色转换介质层并且可以产生红光和绿光。在这种情况下，蓝灯通过非转换层并漫射和散射蓝光。通过液晶层的UV射线进入颜色转换介质层，并且可以产生红光，绿光和蓝光。

