



US008248568B2

(12) **United States Patent**
Anjo et al.

(10) **Patent No.:** **US 8,248,568 B2**
(45) **Date of Patent:** **Aug. 21, 2012**

(54) **LIQUID CRYSTAL DISPLAY DEVICE**

(75) Inventors: **Kenji Anjo**, Oamishirasato (JP);
Takahiro Nagami, Mobara (JP);
Kenichi Hatakeyama, Mobara (JP)

(73) Assignees: **Hitachi Displays, Ltd.**, Chiba (JP);
Panasonic Liquid Crystal Display Co., Ltd., Hyogo-ken (JP)

(*) Notice: Subject to any disclaimer, the term of this patent is extended or adjusted under 35 U.S.C. 154(b) by 523 days.

(21) Appl. No.: **12/430,973**

(22) Filed: **Apr. 28, 2009**

(65) **Prior Publication Data**

US 2009/0268145 A1 Oct. 29, 2009

(30) **Foreign Application Priority Data**

Apr. 28, 2008 (JP) 2008-116981

(51) **Int. Cl.**
G02F 1/1345 (2006.01)

(52) **U.S. Cl.** **349/152; 349/153; 349/139**

(58) **Field of Classification Search** **349/152**
See application file for complete search history.

(56) **References Cited**

U.S. PATENT DOCUMENTS

7,561,239 B2 * 7/2009 Fujita 349/142

FOREIGN PATENT DOCUMENTS

JP 2005-275054 10/2005

* cited by examiner

Primary Examiner — Eric Wong

(74) *Attorney, Agent, or Firm* — Antonelli, Terry, Stout & Kraus, LLP.

(57) **ABSTRACT**

An IPS type liquid crystal display device capable of preventing a blanking phenomenon generated to the periphery of a screen caused by charging at the inside of a counter substrate due to the effect of a gate voltage applied to scanning line leads. In a pixel area A constituting a display region, a pixel electrode is disposed by way of an insulative film above a common electrode formed in a planar shape. In a scanning line lead area, the scanning line leads have first scanning line leads and second scanning lines formed in different layers for decreasing the width of the scanning line lead area. The scanning line leads are covered with a shield electrode formed coplanar with the common electrode. Since the shield electrode is extended as far as a portion below a sealant, the shielding effect is enhanced. Further, since the insulative film is present between the sealant and the shield electrode, the sealing effect is not deteriorated.

12 Claims, 7 Drawing Sheets

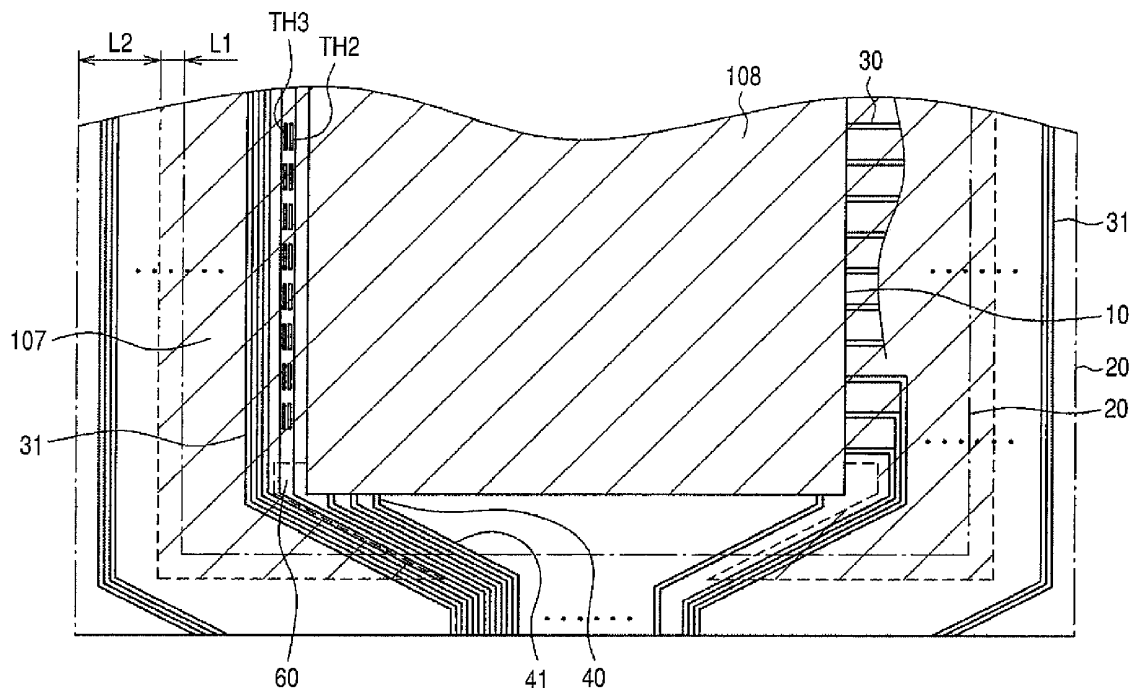

FIG. 1

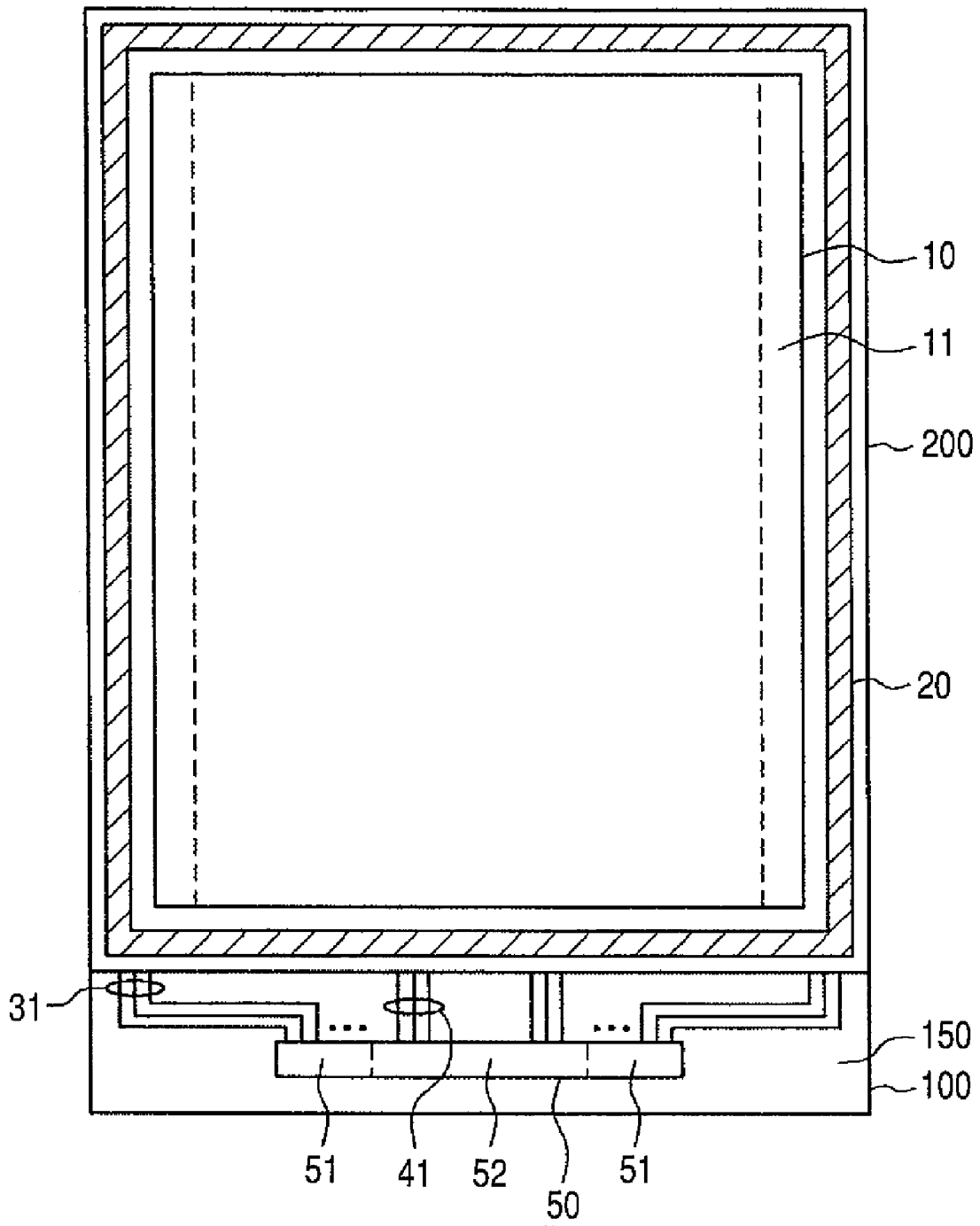

FIG. 2

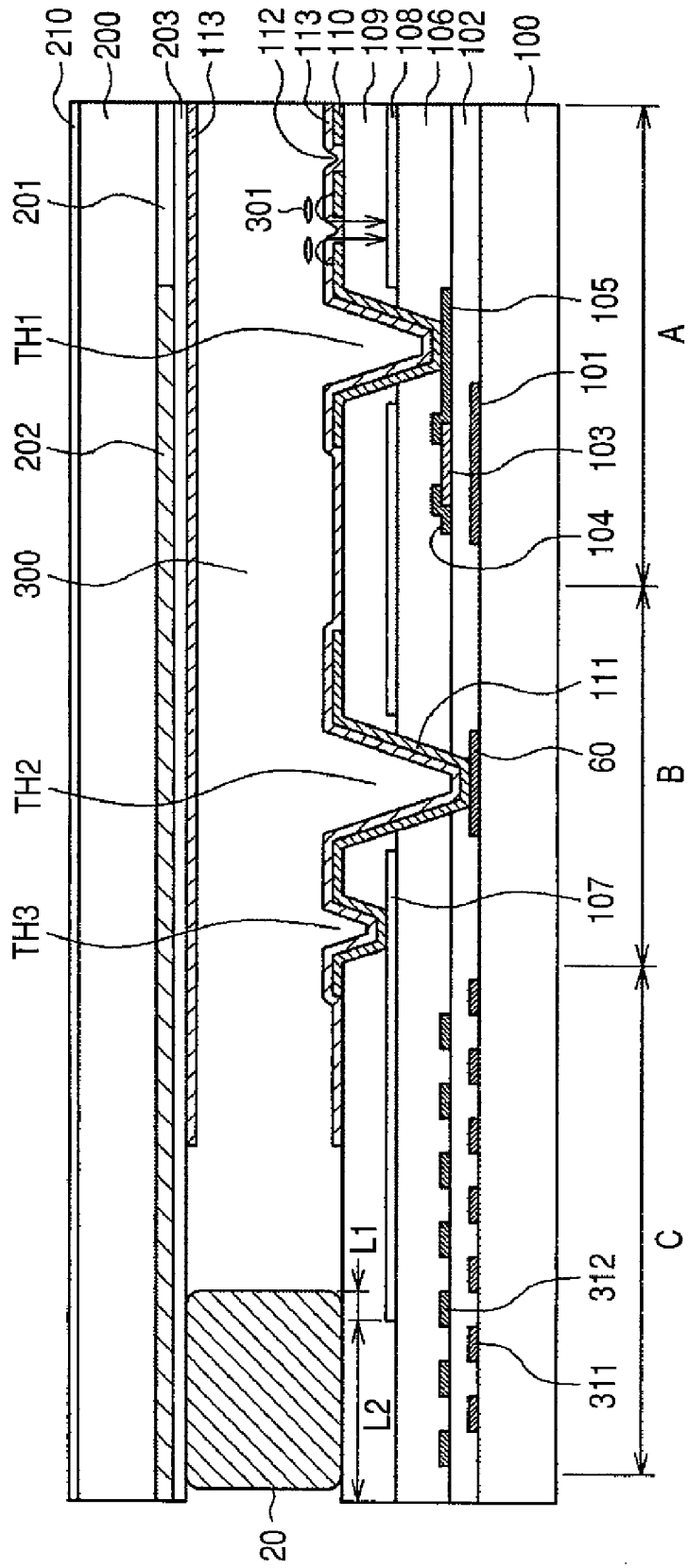

FIG. 3

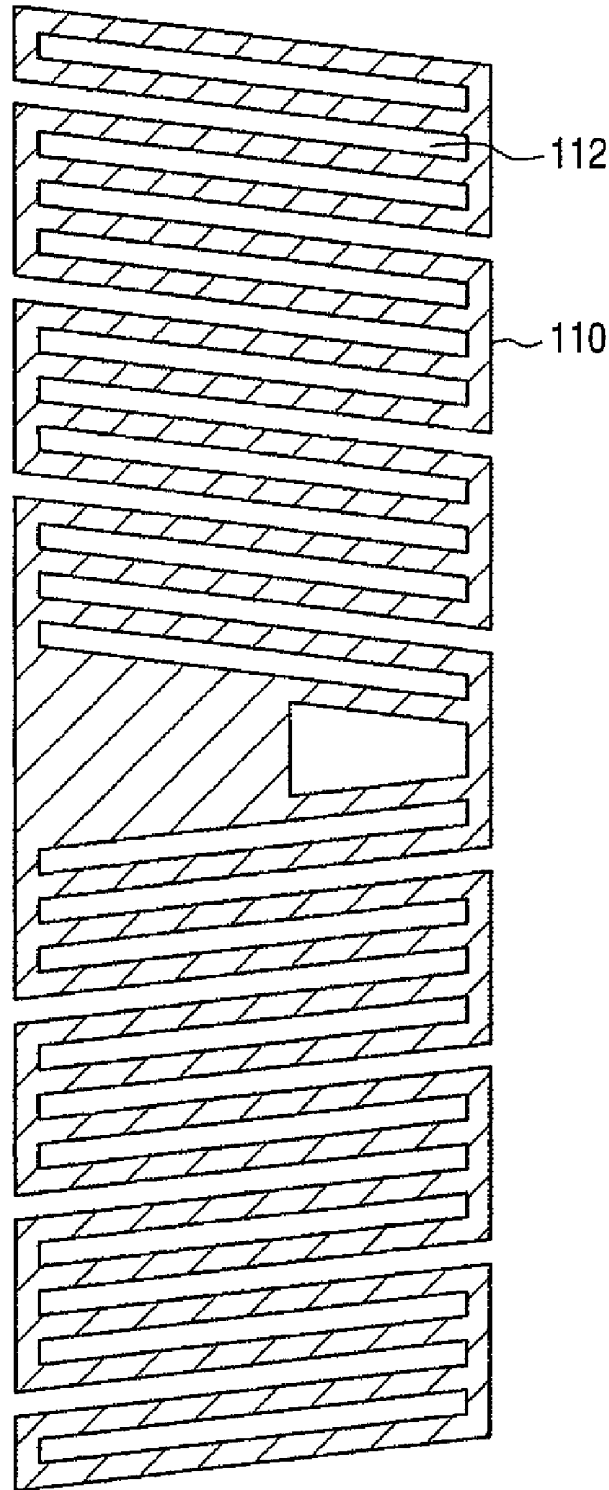

FIG. 4

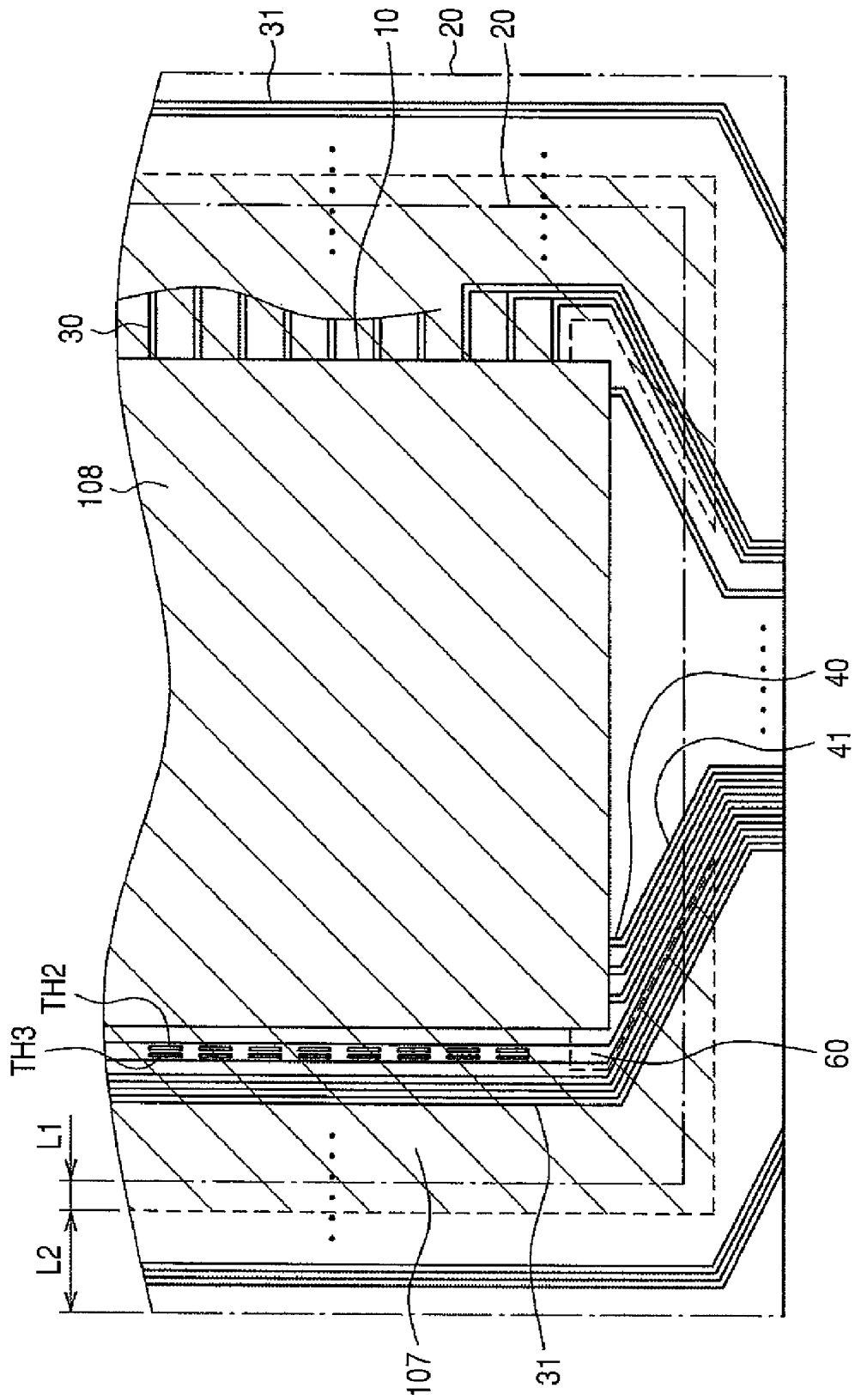

FIG. 5

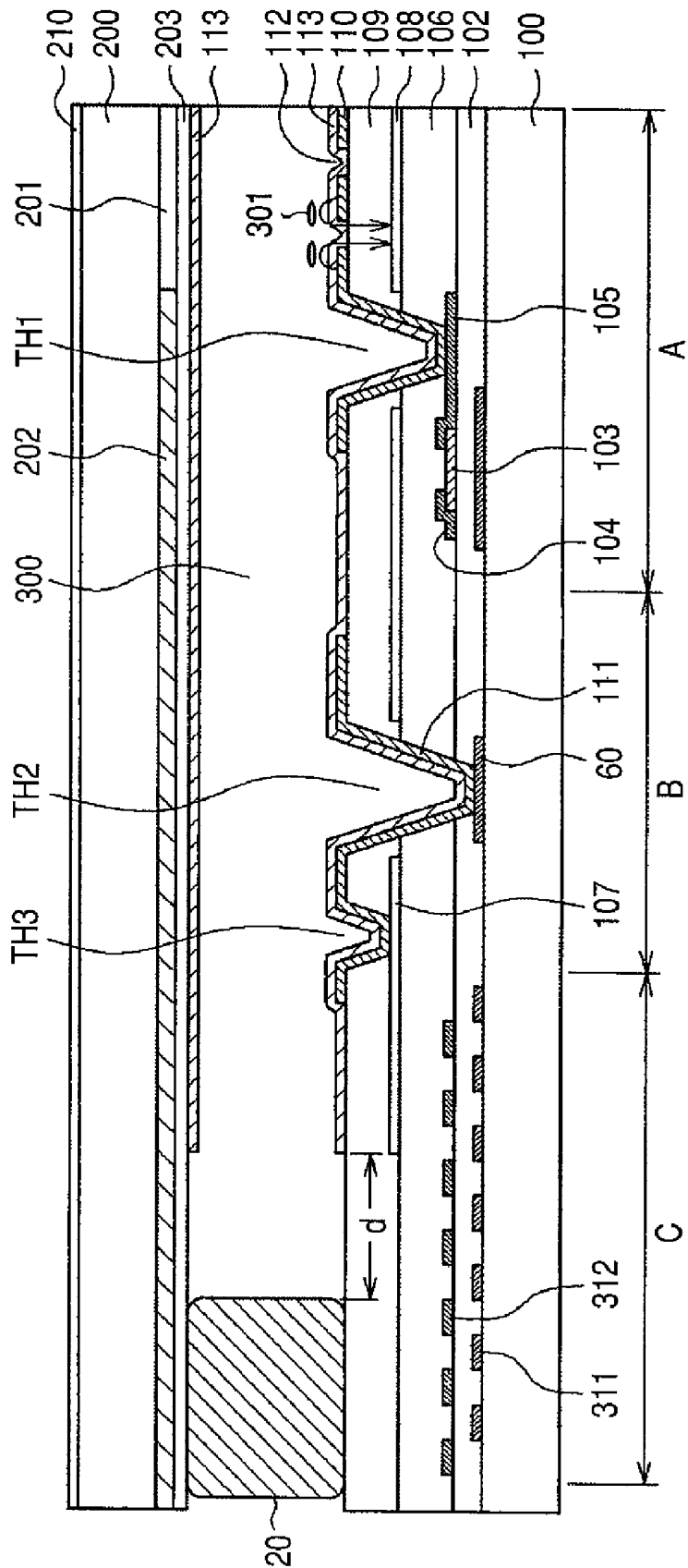

FIG. 6

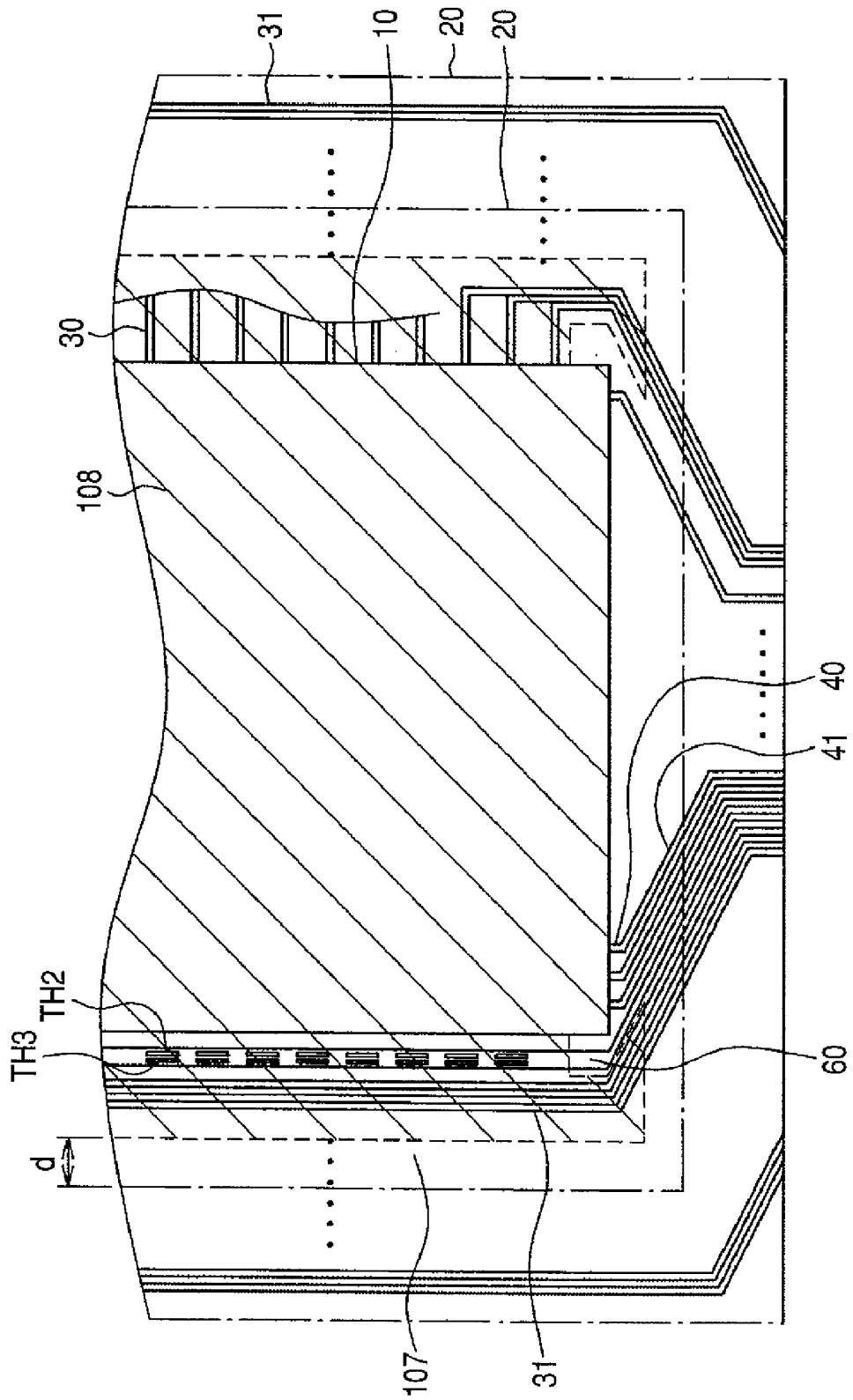
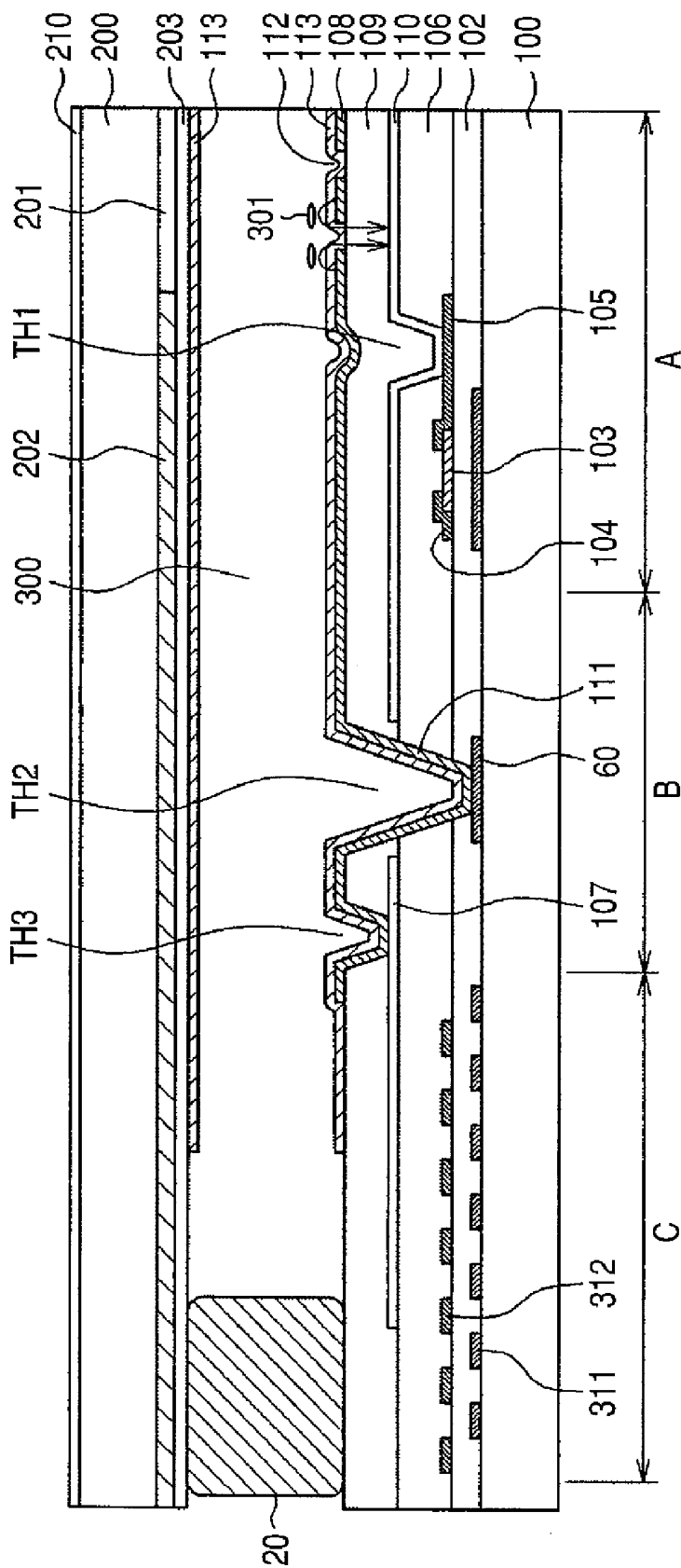

FIG. 7



LIQUID CRYSTAL DISPLAY DEVICE

CLAIM OF PRIORITY

The present application claims priority from Japanese Patent Application JP 2008-116981 filed on Apr. 28, 2008, the content of which is hereby incorporated by reference into this application.

BACKGROUND OF THE INVENTION

1. Field of the Invention

The present invention concerns a display device and, particularly, it relates to a liquid crystal display device of an in-plane electric field system (IPS) excellent in view angle characteristics with no image unevenness also at the periphery of a display region.

2. Description of Related Art

In a liquid crystal display device, a TFT substrate having pixel electrodes and thin film transistors (TFT) formed in a matrix and a counter substrate opposed to the TFT substrate and having color filters, etc., formed at portions corresponding to the pixel electrode of the TFT substrate are disposed, and liquid crystals are put between the TFT substrate and the counter substrate. Then, images are formed by controlling the transmittance of a light by liquid crystal molecules on every pixel.

Since the liquid crystal display device is flat and light in weight, application use thereof has been extended in various fields. Small-sized liquid crystal display devices are generally used for cellular phones, DSC (Digital Still Cameras), etc. In the cellular phones and DSC, there exists a demand of enlarging the size of the display screen while keeping the outer shape of a liquid crystal display device small. Then, a so-called frame at the periphery of the display region is reduced. In such a constitution, the periphery of the display region tends to undergo the effect of potential fluctuation at, etc. at the frame portion.

On the other hand, view angle characteristics become a problem in the liquid crystal display devices. The view angle characteristics concern a phenomenon that the luminance or chromaticity changes between a case of observing a screen at the front and a case of observing the screen obliquely. For the view angle characteristics, an IPS (in plane switching system) of operating liquid crystal molecules by an electric field in a horizontal direction has excellent characteristics.

Japanese Unexamined Patent Publication No. 2005-275054 describes a liquid crystal display device of the IPS system in which a tapered portion of scanning line leads is covered with a conductive film by way of an insulative film so that blanking does not occur at the periphery of a display region by noises from the scanning line leads. That is, a pitch in the terminal portion for connecting the scanning lines with external circuits is smaller than the pitch of the scanning lines formed in the display region. Then, the scanning line leads that connect the terminal portion with the scanning lines of the display region are in the form of oblique (tapered) wirings for adjusting the pitch between the display region and the terminal portion. In the oblique wiring portion, since the wiring density is higher than that in the display region and noises due to scanning signals tend to be generated, it is intended to cover the portion with the conductive film thereby reducing the effect of the noises from the tapered portion in JP-A No. 2005-275054. For the conductive film, ITO (indium tin oxide) which is identical with that used for the pixel electrode is used.

In the constitution described in JP-A No. 2005-275054, the scanning line lead is covered with ITO which is identical with that used for the pixel electrode. In a case of covering the scanning line lead with ITO, close adhesion between ITO and a sealant causes a problem. An epoxy resin is generally used for the sealant. The sealant has good adhesion with an insulative film such as made of SiN and can maintain a favorable sealing property. However, in a case where the sealant is in direct contact with the conductive film such as an ITO film, reliability of sealing is not always known.

As in the constitution described in JP-A No. 2005-275054, when the scanning line lead is covered with ITO that is formed at the same time with the pixel electrode, this causes a problem for the reliability depending on the relation between ITO and the sealant. Further, while the extent of covering the region of the peripheral ITO gives a significant effect on the shielding effect to the scanning line leads, JP-A No. 2005-275054 has no descriptions for such a problem.

Further, in the constitution of JP-A No. 2005-275054, since ITO used for shielding the scanning line lead is identical with that used for the pixel electrode, it can not be formed continuously from the display region, to result in a portion where the scanning line lead is not covered with ITO at the boundary between the scanning line and the scanning line lead portion. Then, the effect of scanning signals is generated from the portion not covered with ITO.

The present invention intends to eliminate blanking due to the effect of scanning in the display region in a liquid crystal display device of the IPS system, while maintaining the sealing reliability by a sealant.

SUMMARY OF THE INVENTION

The present invention intends to overcome the problems described above in accordance with the specific constitutions described above.

(1) A liquid crystal display device in which a liquid crystal layer is put between a TFT substrate having a first electrode formed in a planar shape, a second electrode disposed above the first electrode by way of an insulative film, and a display region where pixels each formed with a TFT are arranged in a matrix, and a counter substrate opposed to the TFT substrate and formed with a color filter, and the liquid crystal layer is sealed by a sealant formed at the periphery of the TFT substrate and the counter substrate,

wherein scanning lines are extended in a first direction and arranged in a second direction, and video signal lines are extended in the second direction and arranged in the first direction in the display region,

scanning line leads that connect the scanning lines with a scanning line driving circuit are formed to the outside of the display region,

a shield electrode formed coplanar with the first electrode is extended as far as a portion below the sealant while covering the scanning line leads, and the insulative film is present between the shield electrode and the sealant, and

a potential identical with a potential of the first electrode is applied to the shield electrode.

(2) The liquid crystal display device according to (1) described above, wherein the second electrode is an interdigitated electrode.

(3) The liquid crystal display device according to (1) described above, wherein a portion overlapped with the sealant and a portion not overlapped therewith in a planar view are present in the shield electrode, and a width L1 for the overlapped portion and a width L2 for the non-overlapped portion are defined as: $L2 > L1$.

(4) The liquid crystal display device according to (1) described above, wherein video signal line leads that connect the video signal lines with a video signal driving circuit are formed to the outside of the display region, and the shield electrode does not cover the video signal line leads.

(5) The liquid crystal display device according to (1) described above, wherein the first electrode and the shield electrode are formed as a continuous film.

(6) A liquid crystal display device in which a liquid crystal layer is put between a TFT substrate having a first electrode formed in a planar shape, a second electrode disposed above the first electrode by way of an insulative film, and a display region where pixels each formed with a TFT are arranged in a matrix, and a counter substrate opposed to the TFT substrate and formed with a color filter, and the liquid crystal layer is sealed by a sealant formed at the periphery of the TFT substrate and the counter substrate,

wherein scanning lines are extended in a first direction and arranged in a second direction, and video signal lines are extended in the second direction and arranged in the first direction in the display region of the TFT,

scanning line leads that connect the scanning lines with a scanning line driving circuit are formed to the outside of the display region,

a shield electrode formed coplanar with the first electrode is extended as far as a portion below the sealant while covering the scanning line leads, and the insulative film is present between the shield electrode and the sealant, and

a potential identical with a potential of the second electrode is applied to the shield electrode.

(7) The liquid crystal display device according to (6) described above, wherein the second electrode is an interdigitated electrode.

(8) The liquid crystal display device according to (6) described above, wherein a portion overlapped with the sealant and another portion not overlapped therewith in a planar view are present in the shield electrode, and a width $L1$ for the overlapped portion and a width $L2$ for the non-overlapped portion are defined as: $L2 > L1$.

(9) A liquid crystal display device in which a liquid crystal layer is put between a TFT substrate having a first electrode formed in a planar shape, a second electrode disposed above the first electrode by way of an insulative film, and a display region where pixels each formed with a TFT are arranged in a matrix, and a counter substrate opposed to the TFT substrate and formed with a color filter, and the liquid crystal layer is sealed by a sealant formed at the periphery of the TFT substrate and the counter substrate,

wherein scanning lines are extended in a first direction and arranged in a second direction, and video signal lines are extended in the second direction and arranged in the first direction in the display region of the TFT,

a scanning line driving circuit is disposed to the outside of the sealant in the second direction, and scanning line leads for connecting the scanning lines with the scanning line driving circuit are extended in the second direction to the outside of the display region,

a shield electrode formed coplanar with the first electrode is extended as far as a portion below the sealant while covering the scanning line leads, and the insulative film is present between the shield electrode and the sealant, and

a potential identical with a potential of the first electrode is applied to the shield electrode.

(10) The liquid crystal display device according to (9) described above, wherein the scanning line leads extending

in the second direction are formed below the sealant, and an insulative film is present between the sealant and the scanning line leads.

(11) The liquid crystal display device according to (9) described above, wherein the scanning line leads include first scanning line leads and second scanning line leads formed in a layer different from the first scanning line lead by way of an insulative film, and an insulative film is present between the first scanning line leads and the second scanning line leads, and the sealant.

(12) A liquid crystal display device in which a liquid crystal layer is put between a TFT substrate having a first electrode formed in a planar shape, a second electrode disposed above the first electrode by way of an insulative film, and a display region where pixels each formed with a TFT are arranged in a matrix, and a counter substrate opposed to the TFT substrate and formed with a color filter, and the liquid crystal layer is sealed by a sealant formed at the periphery of the TFT substrate and the counter substrate,

wherein scanning lines are extended in a first direction and arranged in a second direction, and video signal lines are extended in the second direction and arranged in the first direction in the display region,

a scanning line driving circuit is disposed to the outside of the sealant in the second direction, and scanning line leads for connecting the scanning lines with the scanning line driving circuit are extended in the second direction to the outside of the display region,

a shield electrode formed coplanar with the first electrode is extended as far as a portion below the sealant while covering the scanning line leads, and the insulative film is present between the shield electrode and the sealant, and

a potential identical with a potential of the second electrode is applied to the shield electrode.

(13) The liquid crystal display device according to (12) described above, wherein the scanning line leads extending in the second direction are formed below the sealant, and an insulative film is present between the sealant and the scanning line leads.

(14) The liquid crystal display device according to (12) described above, wherein the scanning line leads include first scanning line leads and second scanning line leads formed in a layer different from the first scanning line leads by way of an insulative film, and an insulative film is present between the first scanning line leads and the second scanning line leads, and the sealant.

According to the invention, since the scanning line leads for supplying a gate voltage to the scanning lines are covered with the shield electrode applied with a common voltage, charging to the common electrode by the gate voltage can be prevented, and a blanking phenomenon generated at the periphery of the display region due to the charging by the counter substrate can be prevented.

Further, in the invention, since the shield electrode is extended as far as the portion below the sealant, effect of the gate electrode applied to the scanning line leads can be prevented more reliably. Further, in the invention, since the insulative film is disposed between the shield electrode and the sealant, deterioration of the sealing effect for the sealant can be prevented.

DETAILED DESCRIPTION OF THE ACCOMPANYING DRAWINGS

FIG. 1 is a plan view of a liquid crystal display device according to the present invention;

FIG. 2 is a cross sectional view of the liquid crystal display device of the invention;

FIG. 3 is a plan view of the pixel electrode shown in FIG. 2;

FIG. 4 is a plan view of a TFT substrate of the liquid crystal display device of the invention;

FIG. 5 is a cross sectional view of a liquid crystal display device of a comparative embodiment;

FIG. 6 is a plan view of a TFT substrate of the liquid crystal display device of the comparative embodiment; and

FIG. 7 is a cross sectional view of a liquid crystal display device as a second embodiment of the invention.

PREFERRED EMBODIMENTS OF THE INVENTION

The present invention is to be described specifically by way of the following preferred embodiments.

[Embodiment 1]

FIG. 1 is a plan view of a liquid crystal display device applied with the present invention which is used, for example, in cellular phones. In FIG. 1, a counter substrate 200 is disposed above a TFT substrate 100. A liquid crystal layer is put between the TFT substrate 100 and the counter substrate 200. The TFT substrate 100 and the counter substrate 200 are bonded by a sealant 20 formed to a frame portion. The TFT substrate 100 is made larger than the counter substrate 200, in which a terminal portion 150 for supplying a power source, video signals, scanning signals, etc. to the TFT substrate 100 is formed to a portion of the TFT substrate which is made larger than the counter substrate 200.

Further, an IC driver 50 for driving scanning lines, video signal lines, etc. are disposed to the terminal portion 150. The IC driver 50 is divided into three regions in which a video signal driving circuit 52 is disposed at a central portion and scanning signal driving circuits 51 are disposed on both sides of them.

In the display region 10 shown in FIG. 1, unillustrated scanning lines are extended in the lateral direction and arranged in the vertical direction. Further, unillustrated video signal lines are extended in the vertical direction and arranged in the lateral direction. The scanning lines are connected by way of the scanning line leads 31 to the scanning signal driving circuits 51 of the IC driver 50. In FIG. 1, since the display region 10 is arranged at the central portion of the liquid crystal display device, the scanning line leads 31 are disposed on both sides of the display region 10 and, accordingly, the scanning line driving circuits 51 are disposed on both sides of the IC driver 50. On the other hand, video signal line leads 41 that connect the video signal lines with the IC driver 50 are gathered on the lower side of the screen. The video signal line leads 41 are connected with the video signal driving circuit 52 disposed at the central portion of the IC driver 50.

Since the scanning signals supply a gate voltage for turning TFT on or off, this voltage is high. Accordingly, the scanning signals more tend to cause noises in the inside of the liquid crystal display device compared with video signals, etc. Particularly, the periphery of the screen where the scanning line leads 31 are present is liable to undergo the effect of the scanning signals as will be described later. As a result, blanking 11 occurs in a region as shown by dotted lines in FIG. 1. The portion for the blanking 11 is in a state where the contrast is deteriorated.

FIG. 2 is a cross sectional view showing the constitution of the invention which is adapted so as not to cause such blanking. The liquid crystal display device shown in FIG. 2 is a

liquid crystal display device of an IPS system. FIG. 4 is a plan view of a TFT substrate in the identical liquid crystal display device. The liquid crystal device in FIG. 2 includes a section divided from the right side thereof into a pixel area A that constitutes a portion of a display region 10, a common wiring connection area B that connects a common wiring 60 with a shield electrode 107 or a common electrode 108, and a scanning line lead area C. As shown in FIG. 4, since the common electrode 108 and the shield electrode 107 are formed as a continuous film, when a common voltage is supplied to the shield electrode 107, the common voltage is also supplied simultaneously to the common electrode 108.

At first, the constitution of the pixel area in FIG. 2 is to be described. In FIG. 2, a gate electrode 101 is formed above a TFT substrate 100 formed of glass. The gate electrode 101 is formed coplanar with the scanning lines 30. The gate electrode 101 includes an Al alloy and an Mo alloy stacked thereon.

A gate insulator 102 is formed of SiN while covering the gate electrode 101. A semiconductor layer 103 is formed of an a-Si film above the gate insulator 102 at a position opposing to the gate electrode 101. The a-Si film is formed by plasma CVD. The a-Si film forms a channel portion of the TFT, and a source electrode 104 and a drain electrode 105 are formed above the a-Si film while putting the channel portion therebetween. An unillustrated n⁺Si layer is formed between the a-Si film and the source electrode 104 or the drain electrode 105 for establishing an ohmic contact between the semiconductor layer 103 and the source electrode 104 or the drain electrode 105.

The source electrode 104 is used also as video signal lines 40, and the drain electrode 105 is connected with a pixel electrode 110. The source electrode 104 and the drain electrode 105 are formed as a coplanar layer simultaneously. In this embodiment, the source electrode 104 and the drain electrode 105 are formed of an Mo alloy. When it is intended to lower the electric resistance of the source electrode 104 or the drain electrode 105, an electrode structure, for example, including an Al alloy sandwiched between Mo alloys is used.

An inorganic passivation film 106 is formed of SiN and disposed while covering the TFT. The inorganic passivation film 106 protects TFT, particularly, the channel portion thereof against impurities. While an organic passivation film may be formed above the inorganic passivation film 106, only the inorganic passivation film 106 is used in this embodiment.

A common electrode 108 is formed above the inorganic passivation film 106. The common electrode 108 is formed by sputtering ITO (indium tin oxide) as a transparent conductive film over the entire display region 10. That is, the common electrode 108 is formed in a planar shape. After forming the common electrode 108 by sputtering over the entire surface, only the through hole portion for conducting the pixel electrode 110 and the drain electrode 105 is removed by etching the common electrode 108. In this case, the shield electrode 107 to be described later is formed simultaneously.

An upper insulative film 109 is formed of SiN and disposed while covering the common electrode 108. After forming the upper insulative film 109, through holes are formed by etching. A first through hole TH1 is formed by etching the inorganic passivation film 106 using the upper insulative film 109 as a resist. Then, ITO is formed as the pixel electrode 110 by sputtering while covering the upper insulative film 109 and the first through hole TH1. The pixel electrode 110 is formed by patterning the sputtered ITO. ITO as the pixel electrode 110 is deposited also to the first through hole TH1, the second through hole TH2, and the third through hole TH3 simultaneously and patterned simultaneously to form a connection

electrode **111** in the second through hole TH2 and the second through hole TH3. In the first through hole TH1, the drain electrode **105** extended from the TFT and the pixel electrode **110** conduct with each other, and video signals are supplied to the pixel electrode **110**.

FIG. 3 shows an example of the pixel electrode **110**. The pixel electrode **110** is an interdigitated electrode closed at both ends. A slit **112** is formed between digits. Below the pixel electrode **110**, an unillustrated planar common electrode **108** is formed. When the video signals are applied to the pixel electrode **110**, liquid crystal molecules **301** are rotated by lines of electric force generated between the common electrode **108** and the pixel electrode **110** through the slit **112**. This controls a light that passes through the liquid crystal layer **300** to form images.

The pixel area in FIG. 2 explains the state in the cross sectional view. The slit **112** is defined between adjacent interdigitated electrodes. A common voltage is applied to the common electrode **108** and a voltage by the video signal is applied to the pixel electrode **110**. When the voltage is applied to the pixel electrode **110**, as shown in FIG. 2, lines of electric force are generated to rotate the liquid crystal molecules **301** in the direction of the lines of electric force to thereby control the transmittance of a light from a back light. Since the light transmittance from the back light is controlled on every pixels, images are formed. An alignment film **113** is formed above the pixel electrode **110** for aligning the liquid crystal molecules **301**.

In FIG. 2, a counter substrate **200** is disposed while sandwiching a liquid crystal layer **300** relative to the TFT substrate. A color filter **201** is formed at the inside of the counter substrate **200**. As the color filter **201**, red, green, and blue color filters **201** are formed on every pixels to form color images. A black matrix **202** is formed between a color filter **201** and another color filter **201** adjacent thereto to improve the contrast of images. However, since FIG. 2 is a cross sectional view for the periphery of the display region **10**, the color filter **201** is shown only for one color and a most portion is covered with the black matrix **202** as a light shielding film.

An over coat film **203** is formed while covering the color filter **201** and the black matrix **202**. Since the surface of the color filter **201** and the black matrix **202** is uneven, the surface is planarized by the overcoat film **203**. An alignment film **113** for aligning the liquid crystal molecules **301** is formed on the overcoat film **203**. Since FIG. 2 shows the IPS, the common electrode **108** is formed on the side of the TFT substrate **100** and not formed on the side of the common electrode **200**.

As shown in FIG. 2, a conductive film is not formed to the inside of the counter substrate **200** in the IPS system. Then, the potential of the counter substrate **200** becomes instable. Further, electromagnetic noises from the outside intrude into the liquid crystal layer **300** to give undesired effects on the images. In order to eliminate such a problem, a surface conductive film **210** is formed to the outside of the counter substrate **200**. The surface conductive film **210** is formed by sputtering ITO as a transparent conductive film.

As described above, while electromagnetic noises, etc. from the outside of the liquid crystal display device can be shielded by the surface conductive film **210**, charges in the inside of the liquid crystal display device by the effect of the gate voltage or the like that are generated in the inside of the liquid crystal display device can not be coped with by the surface conductive film **210**. Such a problem is coped with by the constitution of the invention to be described later.

A common voltage is applied to the common electrode **108** from the common wiring **60**. The common wiring **60** is formed coplanar with the scanning lines **30** or the gate elec-

trode **101**. In FIG. 2, the common electrode **108** and the shield electrode **107** covering the scanning line leads **31** are formed as a continuous film as shown in FIG. 4. Accordingly, as shown in FIG. 2, when the common wiring **60** and the shield electrode **107** are connected, the common wiring **60** and the common electrode **108** are connected at the same time.

The common wiring **60** and the shield electrode **107** are connected as described below. A through hole is formed in the upper insulative film **109**, the inorganic passivation film **106**, and the gate insulator **102** to expose a portion of the common wiring **60**. On the other hand, a through hole is formed in the upper insulative film **109** to expose a portion of the shield electrode **107**. Then, when an ITO film for forming the pixel electrode **110** is sputtered, ITO is deposited at the same time and the ITO film is patterned simultaneously with the pixel electrode **110** to thereby form a connection electrode **111** and connect the shield electrode **107** with the common electrode **108**.

In FIG. 2, the scanning line lead area C is a portion showing the characteristic feature of the invention. The scanning line leads **31** in FIG. 2 have a two-layered structure. Particularly, in a small sized liquid crystal display device, it is strongly demanded to narrow the frame portion at the periphery of the display region **10**. The scanning line leads **31** are disposed in the frame portion at the outside of the display region **10**. In a case where the scanning line leads **31** are disposed in a coplanar layer, it is necessary to take a distance between each of the scanning line leads **31** and this imposes a limit on the narrowing of the frame portion.

In the scanning line lead area C in FIG. 2, the space occupied by the scanning line leads **31** is decreased by disposing the scanning line leads **31** separately into two layers, that is, first scanning line leads **311** and second scanning line leads **312**. In FIG. 2, the first scanning line leads **311** are formed coplanar with the scanning lines **30** or the gate electrode **101**, and the second scanning line leads **312** are formed coplanar with the video signal lines **40** or the drain electrode **105**. The scanning lines **30** and the second scanning line leads **312** are connected by a through hole not illustrated in FIG. 2.

Since the gate insulator **102** is present between the first scanning line leads **311** and the second scanning line leads **312**, the first scanning line leads **311** and the second scanning line leads **312** can be arranged with no gaps therebetween or in superposition to each other in a planar view. Accordingly, the frame region can be narrowed.

A gate voltage at a relatively high voltage for turning the TFT on and off is applied to the scanning lines **30** and the scanning line leads **31**. Particularly, when the scanning line leads **31** are not covered with the shield electrode **107** or the like, a portion of the common electrode **108** is charged by the effect of the gate voltage. Particularly, when the black matrix **202** formed to the counter substrate **200** is formed of a resin or the like as an insulator, the black matrix **202** is liable to be charged. When the counter substrate **200** is charged, the effect prevails as far as the liquid crystal layer **300** and noises are formed in the video signals to generate the blanking at the periphery of the screen.

In the invention, the effect of the gate voltage on the counter substrate **200** is prevented by extending the shield electrode **107** formed simultaneously with the common electrode **108** as far as a portion below the sealant **20** and completely covering the scanning line leads **31**. The shield electrode **107** is formed of an ITO film which is identical with that used for the common electrode **108**. Further, an inorganic passivation film **106** formed of SiN is present between the second scanning line leads **312** and the shield electrode **107**.

The shield electrode **107** is covered with the upper insulative film **109**. Accordingly, the sealant **20** and ITO constituting the shield electrode **107** are not in direct contact with each other. Accordingly, the sealant **20** is in contact with the upper insulative film **109** as an insulator to enhance the reliability for the seal portion.

The shield electrode **107** is extended to the portion below the sealant **20** thereby improving the shielding effect for the scanning line leads **31**. However, the shield line is not extended beyond the sealant **20** as far as the outside. This is for preventing that the bonding strength at the boundary between the ITO film constituting the shield electrode **107** and the upper insulative film **109** or the inorganic passivation film **106** gives undesired effects on the sealing reliability.

Accordingly, for the shield electrode **107**, a region **L1** overlapped with the sealant **20** and a region **L2** not overlapped with the sealant **20** are present below the sealant **20** as shown in FIG. 2. For maintaining a high reliability of the sealing portion, it is desirable to define the regions as: $L2 > L1$.

FIG. 4 is a plan view of the TFT substrate **100** of the liquid crystal display device according to the invention. In FIG. 4, the TFT substrate **100** is disposed as far as the sealant **20**. The sealant **20** is shown by a dotted chain. In FIG. 4, the scanning lines **30** are extended in the lateral direction and arranged in the vertical direction in the display region **10**. Further, the video signal lines **40** are extended in the vertical direction and arranged in the lateral direction. The scanning lines **30** are connected with the scanning line leads **31** present on both sides of the display region **10**. Further, the video signal lines **40** are connected with the video signal lines leads **41** that are present below the display region **10**.

The scanning line leads **31** present on both sides of the display region **10** are extended to a portion lower than the display region **10** and connected with the scanning line driving circuits **51** of the IC driver **50**. The video signal line leads **41** present at a lower side of the display region **10** are connected with the video signal driving circuit **52** which is present to a further lower side of the display region **10**. In FIG. 4, the scanning lines **31** are present with no gaps to each other in a planar view. As has been described above with reference FIG. 2 such an arrangement is possible, since the scanning lines **31** have a two-layered structure and they are insulated from each other by the insulation film.

In FIG. 4, the common wiring **60** is extended on the right of the display region **10**, and the common wiring **60** is connected by way of the second through hole TH2 and the third through hole TH3 to the shield electrode **107** and the common electrode **108** formed as a film in contiguous with the shield electrode **107**. The display region **10** is entirely covered with the common electrode **108** and the scanning line leads **31** present on both sides of the display region **10** are covered with the shield electrode **107**. The common electrode **108** and the shield electrode **107** are formed of a continuous film and this is shown by hatched lines. Accordingly, at the inside of the sealant **20**, the scanning lines **30** and the scanning line leads **31** are entirely covered with the common electrode **108** or the shield electrode **107** formed of ITO. While the shield electrode **107** covers the scanning line leads **31**, it does not cover the video signal line leads **41**. This is because the video signal voltage is low and the signal is unlikely to charge the counter substrate **200**. When the shield electrode **107** covers the video signal line leads **41**, the capacitance between the video signal line leads **41** is increased to possibly give undesired effects on the processing speed of the video signals depending on the case.

The shield electrode **107** is overlapped with the sealant **20** in a planar view. The amount of overlap between the sealant

20 and the shield electrode **107** is **L1**, while the amount of non-overlap between them is **L2**. As has been described with reference to FIG. 2, the amounts are defined as: $L2 > L1$ in this embodiment. Further, the upper insulative film **109** formed of SiN is present between the shield electrode **107** and the sealant **20** to ensure the reliability of sealing.

The scanning line leads **31** are present also below the sealant **20**, in order to decrease the width of the frame. However, in a case of the first scanning line leads **311** formed coplanar with the gate electrode **101**, three layers of insulative films, that is, the gate insulator **102**, the inorganic passivation film **106**, and the upper insulative film **109** are present between the sealant **20** and the leads **31**. In the case of the second scanning line leads **312** formed coplanar with the drain electrode **105**, two layers of insulative films, that is, the inorganic passivation film **106** and the upper insulative film **109** are present between the sealant **20** and the leads **31**. Accordingly, the sealant is in contact with the insulators and sealing failure does not occur.

As has been described above, according to this embodiment, since the scanning line leads **31** are entirely covered with the shield electrode **107** at the inside of the sealant, this can avoid the problem that the common electrode **108** is charged by the gate voltage. Further, since the shield electrode **107** is formed in contiguous with the common electrode **108** formed in the planar shape, the shield electrode **107** and the common electrode **108** formed in the display region **10** can be connected with no discontinuity and, accordingly, the shield effect is excellent.

Further, according to this embodiment, since the shield electrode **107** formed of ITO and the sealant **20** are not in direct contact but the sealant **20** is in contact only with the insulative film, reliability for the sealing portion is not deteriorated.

FIG. 5 shows a comparative embodiment to the invention. Like FIG. 2, FIG. 5 is a cross sectional view for the periphery of the liquid crystal display device shown in FIG. 1. The constitution of FIG. 5 is identical with the constitution of FIG. 2 except for the shield electrode **107**. In FIG. 5, the shield electrode **107** is not overlapped with the sealant **20**, but a region **d** where the scanning line leads **31** are opposed to the counter substrate **200** by way of the inorganic passivation film **106** and the upper insulative film **109** is present between the inside of the sealant **20** and the end of the shield electrode **107**. Accordingly, the inside of the counter substrate **200** is charged under the effect of the gate potential in the region **d**. Then, the effect of the charge at the inside of the counter substrate **200** exerts on the liquid crystal layer **300** to generate the blanking at the periphery of the screen as shown in FIG. 1.

FIG. 6 is a plan view for a TFT substrate **100** in the comparative embodiment. The constitution in FIG. 6 is identical with that in FIG. 4 except for the range of a shield electrode **107**. In FIG. 6, a sealant **20** is formed at the periphery of a TFT substrate **100**. The sealant is shown by a dotted chain. Scanning line leads **31** are disposed on both sides of a display region **10**. The shield electrode **107** does not cover the inside of the sealant **20** and the end of the display region **10** entirely but it covers only a portion thereof. That is, a region **d** where the scanning line leads **31** are not covered is present at the inside of the sealant **20**. Then, the inside of the counter substrate **200** is charged by the gate voltage applied to the scanning line leads **31** in the region **d** and, as has been described with reference to FIG. 5, blanking occurs at the periphery of the display region **10**. As described above, even when the shield electrode **107** is disposed above the scanning line leads **31** coplanar with the common electrode **108**, no sufficient effect can be obtained against the blanking unless the shield

electrode **107** is extended as far as the overlap range between the shield electrode **107** and the sealant **20**.
[Embodiment 2]

In the liquid crystal display device of the IPS system of Embodiment 1, the planar common electrode **108** is formed above the inorganic passivation film **106**, the upper insulative film **109** is formed thereabove, and the interdigitated pixel electrode **110** is formed further thereabove. Contrary to the arrangement of the electrodes in the liquid crystal display device of Embodiment 1, a planar pixel electrode **110** may be formed on the inorganic passivation film **106** and an interdigitated common electrode **108** may be formed thereabove while sandwiching the upper insulative film **109** between them. The shape of the common electrode **108** in this case may be identical with that for the interdigitated electrode shown in FIG. 3.

In FIG. 7, a planar pixel electrode **110** is formed above the inorganic passivation film **106** in the pixel area. An upper insulative film **109** is formed above the planar pixel electrode **110**, and an interdigitated common electrode **108** is formed above the upper insulative film **109**. The shield electrode **107** covering the scanning line leads **31** is formed of an ITO film simultaneously with the formation of the pixel electrode **110**. The shield electrode **107** is formed by an ITO film simultaneously with the pixel electrode **110**. The shield electrode **107** is formed simultaneously with the formation of the pixel electrode **110** and a common potential is supplied from the common wiring **60** through the second by way of hole TH2 and the third through hole TH3 to the shield electrode **107**. Accordingly, in the Embodiment 2, the ITO film constituting the pixel electrode **110** and the ITO film constituting the shield electrode **107** are not formed as a continuous film.

The constitution as shown in FIG. 7 can be formed by the following process. The process is identical with that of the Embodiment 1 shown in FIG. 2 as far as the formation of the inorganic passivation film **106**. After forming the inorganic passivation film **106**, a first through hole TH1 is formed for connecting the pixel electrode **110** with the drain electrode **105** of the TFT. Then, ITO is sputtered. By patterning the deposited ITO film, the pixel electrode **110**, the contact of the through hole portion, and the shield electrode **107** are formed. In this case, the pixel electrode **110** and the shield electrode **107** are not formed as a continuous film.

Then, the upper insulative film **109** is formed of SiN. Then, in the same manner as in the Embodiment 1, a second through hole TH2 and a third through hole TH3 are formed. Then, ITO as the common electrode **108** is deposited by sputtering. By patterning ITO, the interdigitated common electrode **108** and the contact of the through holes are formed. Among the through holes, only the first through hole TH1 for connecting the drain electrode **105** with the pixel electrode **110** is different from the Embodiment 1 in FIG. 2.

The Embodiment 2 is identical with the Embodiment 1 in that the shield electrode **107** is formed as far as the portion below the sealant **20** in a planar view. Further, it is also identical with the Embodiment 1 in that the common voltage is applied to the shield electrode **107**. Accordingly, the same effect as in the Embodiment 1 can be obtained also in the liquid crystal display device of the IPS system of a type in which the planar pixel electrode **110** is disposed to the lower side and the common electrode **108** is formed thereabove in the interdigitated shape by way of the insulative film.

For the Al alloy forming the gate electrode, the common wiring coplanar therewith, and the second scanning line leads described previously, the Al alloy may be replaced with an AlNd alloy or the Mo alloy may be replaced with an MoCr alloy. In the same manner, for the source electrode or the drain

electrode, the Mo alloy may be sandwiched with MoCr alloys, or the AlNd alloy may be sandwiched with MoCr alloys. It is evident that the alloys described above are not limitative but a structure in which other pure metals or alloys are laminated may also be adopted.

Further, in FIG. 4, FIG. 6, etc., a common voltage is supplied from the common wiring to the shield electrode **107** or the common electrode **108** in the common wiring connection portion at the outside of the display region. However, it is not particularly restricted thereto, but the common wiring **60** may be disposed in parallel with the scanning lines **30** in the display region and a common wiring connection portion of supplying a common voltage to the shield electrode **107** or the common electrode **108** may be disposed in the display region. This can stabilize the potential of the common electrode **108** in the display region. Further, it may also be adopted such that the common wiring connection portion outside of the display region shown in the drawing is not disposed, but the common voltage may be supplied from the common wiring **60** to the shield electrode **107** and the common electrode **108** only by the common wiring connection portion in the display region described previously. This can decrease the area at the outside of the display region.

Further, while the second through hole TH2 and the third through hole TH3 are disposed in combination in the first direction in the common wiring connection portion, they may also be disposed in combination in the second direction. This can decrease the area at the outside of the display region.

As shown in FIG. 4 in this embodiment, crossing between the scanning lines **30** and the common wiring **60** is prevented by driving the scanning lines **30** on the side closer to the terminal portion of the display region by way of the scanning line leads **31** disposed on the right of the TFT substrate, and driving the scanning lines **30** on the side remote from the terminal portion of the display region by way of the scanning line leads **31** disposed on the left of the TFT substrate and providing a common wiring between the display region and the scanning line leads **31** on the left of the TFT substrate. However, the common wirings **60** may be disposed on both right and left sides of the display region and the common wiring connection portion may be disposed to each of them.

In this embodiment, as shown in FIG. 4, FIG. 6, etc., the common wiring **60** is disposed between the scanning line leads **31** and the video line leads **41** at the terminal portion. While the shield electrode **107** covers the scanning line leads **41**, it does not cover the common wiring **60**.

What is claimed is:

1. A liquid crystal display device in which a liquid crystal layer is put between a TFT substrate and a counter substrate, the TFT substrate having a first electrode formed in a planar shape, a second electrode disposed above the first electrode by way of an insulative film, and a display region where pixels each formed with a TFT are arranged in a matrix, the counter substrate being disposed opposed to the TFT substrate and formed with a color filter, and the liquid crystal layer is sealed by a sealant formed at the periphery of the TFT substrate and the counter substrate, wherein an electrical field generated between the first electrode and the second electrode on the TFT substrate rotates liquid crystal molecules of the liquid crystal layer so as to control a transmittance of a light from a back-light, wherein scanning lines are extended in a first direction and arranged in a second direction, and video signal lines are extended in the second direction and arranged in the first direction in the display region,

wherein scanning line leads that connect the scanning lines with a scanning line driving circuit are formed to the outside of the display region,

wherein a shield electrode formed coplanar with the first electrode is extended as far as a portion below the sealant while covering the scanning line leads, and the insulative film is present between the shield electrode and the sealant,

wherein a potential identical with a potential of the first electrode is applied to the shield electrode, and wherein a portion overlapped with the sealant and another portion not overlapped therewith in a planar view are present in the shield electrode, and a width L1 for the overlapped portion and a width L2 for the non-overlapped portion are defined as: $L2 > L1$.

2. The liquid crystal display device according to claim 1, wherein the second electrode is an interdigitated electrode.

3. The liquid crystal display device according to claim 1, wherein video signal line leads that connect the video signal lines with a video signal driving circuit are formed to the outside of the display region, and the shield electrode does not cover the video signal line leads.

4. The liquid crystal display device according to claim 1, wherein the first electrode and the shield electrode are formed on a continuous film.

5. A liquid crystal display device in which a liquid crystal layer is put between a TFT substrate and a counter substrate, the TFT substrate having a first electrode formed in a planar shape, a second electrode disposed above the first electrode by way of an insulative film, and a display region where pixels each formed with a TFT are arranged in a matrix,

the counter substrate being disposed opposed to the TFT substrate and formed with a color filter, and

the liquid crystal layer is sealed by a sealant formed at the periphery of the TFT substrate and the counter substrate, wherein an electric field generated between the first electrode and the second electrode on the TFT substrate rotates liquid crystal molecules of the liquid crystal layer so as to control a transmittance of a light from a back-light,

wherein scanning lines are extended in a first direction and arranged in a second direction, and video signal lines are extended in the second direction and arranged in the first direction in the display region,

wherein scanning line leads that connect the scanning lines with a scanning line driving circuit are formed to the outside of the display region,

wherein a shield electrode formed coplanar with the first electrode is extended as far as a portion below the sealant while covering the scanning line leads, and the insulative film is present between the shield electrode and the sealant,

wherein a potential identical with a potential of the second electrode is applied to the shield electrode, and

wherein a portion overlapped with the sealant and another portion not overlapped therewith in a planar view are present in the shield electrode, and a width L1 for the overlapped portion and a width L2 for the non-overlapped portion are defined as: $L2 > L1$.

6. The liquid crystal display device according to claim 5, wherein the second electrode is an interdigitated electrode.

7. A liquid crystal display device in which a liquid crystal layer is put between a TFT substrate and a counter substrate, the TFT substrate having a first electrode formed in a planar shape, a second electrode disposed above the first electrode by way of an insulative film, and a display

region where pixels each formed with a TFT are arranged in a matrix, the counter substrate opposed to the TFT substrate and formed with a color filter, and the liquid crystal layer is sealed by a sealant formed at the periphery of the TFT substrate and the counter substrate,

wherein an electrical field generated between the first electrode and the second electrode on the TFT substrate rotates liquid crystal molecules of the liquid crystal layer so as to control a transmittance of a light from a back-light,

wherein scanning lines are extended in a first direction and arranged in a second direction, and video signal lines are extended in the second direction and arranged in the first direction in the display region,

wherein a scanning line driving circuit is disposed to the outside of the sealant in the second direction, and scanning line leads for connecting the scanning lines with the scanning line driving circuit are extended in the second direction to the outside of the display region,

wherein a shield electrode formed coplanar with the first electrode is extended as far as a portion below the sealant while covering the scanning line leads, and the insulative film is present between the shield electrode and the sealant,

wherein a potential identical with a potential of the first electrode is applied to the shield electrode, and

wherein a portion overlapped with the sealant and another portion not overlapped therewith in a planar view are present in the shield electrode, and a width L1 for the overlapped portion and a width L2 for the non-overlapped portion are defined as: $L2 > L1$.

8. The liquid crystal display device according to claim 7, wherein the scanning lead lines extending in the second direction are formed below the sealant, and an insulative film is present between the sealant and the scanning line leads.

9. The liquid crystal display device according to claim 7, wherein the scanning line leads include first scanning line leads and second scanning line leads formed in a layer different from the first scanning line leads by way of an insulative film, and an insulative film is present between the first scanning line leads and the second scanning line leads, and the sealant.

10. A liquid crystal display device in which a liquid crystal layer is put between a TFT substrate and a counter substrate, the TFT substrate having a first electrode formed in a planar shape, a second electrode disposed above the first electrode by way of an insulative film, and a display region where pixels each formed with a TFT are arranged in a matrix,

the counter substrate being disposed opposed to the TFT substrate and formed with a color filter, and

the liquid crystal layer is sealed by a sealant formed at the periphery of the TFT substrate and the counter substrate, wherein an electric field generated between the first electrode and the second electrode on the TFT substrate rotates liquid crystal molecules of the liquid crystal layer so as to control a transmittance of a light from a back-light,

wherein scanning lines are extended in a first direction and arranged in a second direction, and video signal lines are extended in the second direction and arranged in the first direction in the display region,

wherein a scanning line driving circuit is disposed to the outside of the sealant in the second direction, and scanning line leads for connecting the scanning lines with the scanning line driving circuit are extended in the second direction to the outside of the display region,

15

wherein a shield electrode formed coplanar with the first electrode is extended as far as a portion below the sealant while covering the scanning line leads, and the insulative film is present between the shield electrode and the sealant,

wherein a potential identical with a potential of the second electrode is applied to the shield electrode, and

wherein a portion overlapped with the sealant and another portion not overlapped therewith in a planar view are present in the shield electrode, and a width L1 for the overlapped portion and a width L2 for the non-overlapped portion are defined as: $L2 > L1$.

16

11. The liquid crystal display device according to claim 10, wherein the scanning line leads extending in the second direction are formed below the sealant, and an insulative film is present between the sealant and the scanning line leads.

5 **12.** The liquid crystal display device according to claim 10, wherein the scanning line leads include first scanning line leads and second scanning line leads formed in a layer different from the first scanning line leads by way of an insulative film, and an insulative film is present between the first scanning line leads and the second scanning line leads, and the sealant.

* * * * *

专利名称(译)	液晶显示装置		
公开(公告)号	US8248568	公开(公告)日	2012-08-21
申请号	US12/430973	申请日	2009-04-28
[标]申请(专利权)人(译)	株式会社日立显示器		
申请(专利权)人(译)	日立显示器有限公司.		
当前申请(专利权)人(译)	日本展示INC. 松下液晶显示CO. , LTD.		
[标]发明人	ANJO KENJI NAGAMI TAKAHIRO HATAKEYAMA KENICHI		
发明人	ANJO, KENJI NAGAMI, TAKAHIRO HATAKEYAMA, KENICHI		
IPC分类号	G02F1/1345		
CPC分类号	G02F1/134363 G02F1/1345 G02F1/136209 G02F1/13306 G02F1/133512 G02F1/1339 G02F1/136286 G02F1/133345 G02F2001/13456 G02F2001/134372 G02F2001/136218 G02F1/133514 G02F1/134336 G02F1/13439 G02F1/1368 H01L27/1222 H01L27/124 H01L29/78669		
审查员(译)	黄, ERIC		
优先权	2008116981 2008-04-28 JP		
其他公开文献	US20090268145A1		
外部链接	Espacenet USPTO		

摘要(译)

一种IPS型液晶显示装置，其能够防止由于施加到扫描线引线的栅极电压的影响而在对向基板内部充电引起的屏幕周围产生的消隐现象。在构成显示区域的像素区域A中，像素电极通过绝缘膜设置在形成为平面形状的公共电极上方。在扫描线引线区域中，扫描线引线具有形成在不同层中的第一扫描线引线和第二扫描线，用于减小扫描线引线区域的宽度。扫描线引线覆盖有与公共电极共面形成的屏蔽电极。由于屏蔽电极延伸到密封剂下方的部分，因此增强了屏蔽效果。此外，由于绝缘膜存在于密封剂和屏蔽电极之间，因此密封效果不会降低。

