

(19) World Intellectual Property Organization
International Bureau



(43) International Publication Date
22 March 2001 (22.03.2001)

PCT

(10) International Publication Number
WO 01/20391 A1

(51) International Patent Classification⁷: G02F 1/133,
1/1347, 1/13, 1/1339, G09G 5/00, 3/36, 5/06, H04N 5/66

Ithaca, NY 14850 (US). SKINNER, Dean, W.; 804 Country Club Road, Vestal, NY 13850 (US). YOST, Boris; 1650 Slaterville Road, Ithaca, NY 14850 (US).

(21) International Application Number: PCT/US00/05756

(22) International Filing Date: 2 March 2000 (02.03.2000)

(74) Agent: LEVY, Mark; Salzman & Levy, Suite 902, 19 Chenango Street, Binghamton, NY 13901 (US).

(25) Filing Language: English

(81) Designated States (national): JP, KR.

(26) Publication Language: English

(84) Designated States (regional): European patent (AT, BE, CH, CY, DE, DK, ES, FI, FR, GB, GR, IE, IT, LU, MC, NL, PT, SE).

(30) Priority Data:
09/396,142 15 September 1999 (15.09.1999) US

(71) Applicant: RAINBOW DISPLAYS, INC. [US/US];
Glendale Technology Park, 1071 Perimeter Road West,
Endicott, NY 13760 (US).

Published:
— With international search report.

(72) Inventors: GREENE, Raymond, G; Rt 89, Ovid, NY
14521 (US). KRUSIUS, J., Peter; 3 Alessandro Drive,

For two-letter codes and other abbreviations, refer to the "Guidance Notes on Codes and Abbreviations" appearing at the beginning of each regular issue of the PCT Gazette.

(54) Title: COMPENSATION FOR EDGE EFFECTS AND CELL GAP VARIATION IN TILED FLAT-PANEL, LIQUID CRYSTAL DISPLAYS

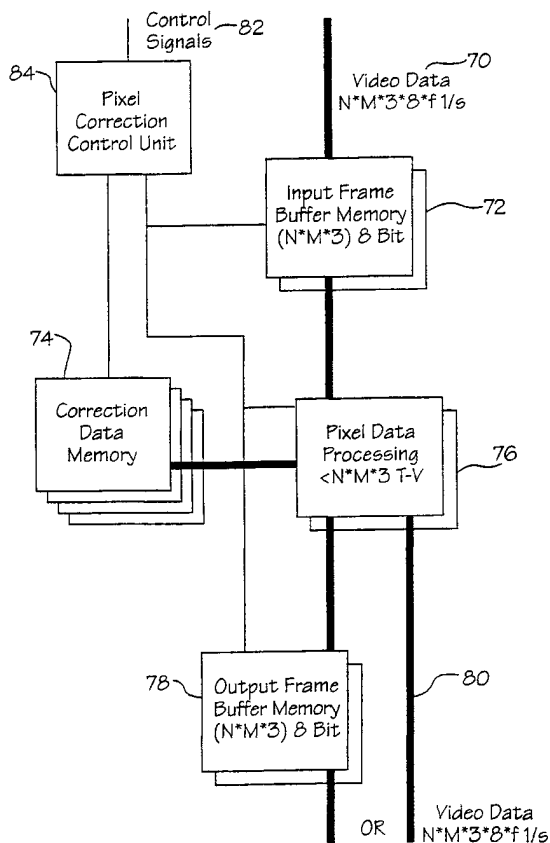

(57) Abstract: The present invention features procedures for correcting discoloration and brightness variations due to liquid crystal cell gap variations or other optical, electro-optical, ambient light, electronic, mechanical, and materials anomalies arising in tiled, flat-panel displays. The purpose of these corrections is to achieve a visually seamless appearance. Absolute, relative and/or smoothing corrections are implemented by performing pixel data video processing by temporarily storing incoming video data (70) in an input frame buffer memory (72), reading the video data (70) from the input frame buffer memory (72) and correction data from the correction data memory (74) under the control of the pixel correction control unit (84) into the pixel data processor (76). Further, the pixel correction control unit (84) may be merged with the pixel data processing unit (76). Also corrected pixel data may be collected in an output frame buffer memory (78) before it is sent to the display. Techniques for determining and applying these corrections are described.



WO 01/20391 A1

COMPENSATION FOR EDGE EFFECTS AND CELL GAP
VARIATION IN TILED FLAT-PANEL, LIQUID CRYSTAL DISPLAYS

Field of the Invention:

The present invention pertains to compensating for
5 brightness and color variations in tiled, liquid crystal
(LC), flat-panel displays and, more particularly, to
compensating means to correct for such changes near the
tile edges due to optical anomalies, electro-optical
aberrations, electronic driving effects, ambient light, LC
10 cell gap, mechanical, or materials variations.

BACKGROUND OF THE INVENTION

Flat-panel displays made in accordance with known
liquid-crystal display (LCD) technologies are both limited
in size and expensive to manufacture. Inexpensive, larger
15 displays can, in principle, be made by assembling smaller
display "tiles", but such a resultant, larger display
generally reveals the seams between the tiles. How to
conceal the seams between tiles, so that the assembled,
large display looks like a continuous, one-piece unit, is
20 very difficult, because the human eye can detect minute
irregularities as long as they are arranged in patterns.

One method for making tiled displays is to connect
four tiles together at common locus lines, using an
adhesive sealant along the seams between adjacent tiles.
25 The tiles are assembled in an in-plane fashion. This type
of construction is shown in co-pending U.S. patent
application bearing Serial No. 08/652,032 (filed on May 21,
1996), entitled "Construction and Sealing of Tiled, Flat-
Panel Displays", hereby incorporated by reference. This
30 method of construction consists of assembling LCD tiles in
a planar fashion, by locating the appropriate alignment

marks disposed on each tile with matching marks on a common reference plate, usually on the cover or back plate. Specific overlay tolerances are required from such an alignment. The tiles are attached to the cover plate and
5 back plate with an optical adhesive. Prior to assembly, the adjacent tile edges are finished such that they in their final position in the assembly provide a seamless appearance. In addition, the cover and/or back plates may contain opaque masks used to "hide" the seams. The back
10 masks can also serve as light collimating means.

Liquid-crystal display tiles may be fabricated in the same manner as monolithic LCDs with one exception: the inner tile edges at the inter-tile seams generally must have pixels located approximately within a pixel pitch from
15 the inner seal edge, so that the pixel pitch across the seam is substantially the same as that on the tiles. In addition the tile edges will usually have design features that control the position of the seal material in relation to the pixel apertures and that contribute to keeping the
20 cell gap uniform. These issues are described in co-pending patent applications Serial No. 08/949,357 (filed October 14, 1997) and Serial No. 09/368,921 (filed August 6, 1999).

As in monolithic LCDs, the two glass plates comprising the LC tile are spaced apart by small transparent balls,
25 while the seal adhesive thickness is generally determined by spacer balls or cylinders embedded in it. Thus there will inherently be some variation in the LC layer thickness near the edges of the tiles. This variation in the LC cell gap causes noticeable discoloration of the pixels near the
30 seams in a tiled, flat-panel LC display. No such artifacts are generally observed on monolithic LCDs because their pixels are never placed into close proximity with the seal located completely outside the pixel array.

A pixel in a color LCD is customarily made up of an
35 aperture opening containing sub-pixels for each primary

color, usually red, green and blue (RGB). Because of spatial variations in the amount of optical retardation experienced by light traveling through the LC cell, different wavelengths of light produce dissimilar visual effects, when variations in the LC cell gap thickness exist. This phenomenon compounds the problems arising in the production of tiled flat-panel liquid crystal displays that are required to exhibit a seamless appearance.

The majority of liquid-crystal display modules made today are digitally controlled devices. An optical transmission-drive voltage relationship (T-V curve) or "gamma curve" relates the digital signal values at the input to the voltage across the liquid crystal cell, and therefore to the luminance of each sub-pixel on the display. Unless otherwise noted, the T-V curve is here considered to be an effective relationship that includes the entire display system response from the electronic drive signal to the resulting luminance. In some color schemes, a linear effective relationship is desired, e.g., the NTSC R, G, B system. In other color schemes a more general weighted response curve is preferred, for example, to meet psychophysiological expectations of the viewer. Color is produced by overlaying color filter layers on top of the sub-pixel apertures. Usually three separate color filters are used to produce primary colors that through additive mixing generate all hues within the desired color gamut. In tiled, liquid crystal displays, small cell gap variations near the seams or between tiles result in changes in the effective T-V curve. As a consequence, a tiled flat panel display has an objectionable, "tiled" appearance, in spite of all efforts to geometrically hide the actual seams. Pixel areas near the seams or the tile boundaries will inevitably become visible, because their effective T-V curves differ from those of pixels in the interior of the tile.

Pixel rows and columns adjacent to the inner seams in a matrix-addressed tiled display also have a somewhat different electro-optical response compared to interior pixels away from the seams. For example, in a display with
5 four tiles, these pixels form visually disturbing vertical and/or horizontal bands around the seams through the center of the tiled display. In particular, it is common for such a tiled display to appear seamless in white and black
10 fields, but have quite visible seams in gray-scale fields between white and black. Since there usually are 256 gray-scale levels for each primary color, there is ample opportunity to reveal the seams, especially combined with the ability of the human eye to detect regular patterns emanating from the seams.

15 Another mechanism that causes color variations in tiled displays arises from the mis-registration of objects in the optical stack. Color filter layers on each tile may be mis-aligned compared to the thin film transistor layer. Also, the external masks on the cover and back
20 plates may be mis-registered compared to alignment marks in the stack. Further, the lateral and height positioning of each tile compared to the color filter and thin film layers always involves alignment tolerances. As a consequence each tile edge show a slightly different response to the
25 partially collimated light beam that is traversing the optical stack of the tiled LC display.

Additionally, the LC domains at pixels close to the inner seams are known to have different electro-optical properties. This may be caused, for example, by solvents
30 leaching into the LC material from the seal adhesive. Furthermore, the absence of adjacent pixels, and therefore fringing electrical fields originating from them, also contributes to the dissimilar characteristics of the electro-optical properties of edge pixels.

The seam areas between tiles usually produce additional anomalous stray light that is absent on pixels away from the seams. Anomalous stray light can originate either from the backlight or ambient light, or be produced in the optical stack of the display. These effects arise either from the discontinuous tiled LCD structure or from imperfections in the manufacture or assembly of the tiled display. For example, specular and diffuse reflections from an irregular tile edge surface finish or sub-surface micro-cracks may occur. Air bubbles in the adhesive, material defects, or chipping of the tile glass edges may also contribute additional light emanating from the pixels near the edge of the tiles. Flaws in the tiles or assembly also tend to cause some depolarization of the light passing through pixels close to the seam areas, thus contributing to a brighter than normal appearance of such edge pixels, yet another optical anomaly at the tile edges. Differences in misalignment of apertures, color filters, or thin film layers among adjacent tiles produces multiple source for stray light at seams. Tile misregistration either in the lateral direction parallel to the glass surfaces (Y, Y direction) or in the perpendicular direction determined by adhesive layers provides further sources. Anomalous light at the seams induced by ambient light will be most pronounced, when the display shows a low luminance image (e.g. close to black levels) and ambient light impinging of the display is strongest.

Further, "artificial" boundaries similar to seams can be created by the electronics used to drive the LC display. These artificial boundaries are common optical artifacts that can be observed on "dual scan" notebook personal computer displays. For example, in a four tile, 2x2 tile array display, boundaries which may exhibit optical artifacts at the tile edges can therefore be caused by "quad scan" control electronics and LC panel drivers. In such a quad-scan drive both row (gate) and column (data) lines for each quadrant of the display are driven

independently using progressive scans. When the voltages, timing, or other elements of such electronic circuits do not match exactly, artificial electronic "seams" may be created. Such electronic "seams" can, of course, also
5 arise on monolithic LCD's which do not have any "physical" seams.

Any corrections made to images on tiled electronic color displays are subject to the luminance and color difference discrimination thresholds of the human vision
10 system. Different threshold criteria apply to abrupt and gradual changes in luminance and chromaticity. These thresholds have been described in our U.S. patent application Serial No. 08/593,759, filed August 26, 1997, now issued as United States Patent No. 5,661,531, as well
15 as our co-pending U.S. patent applications Serial Nos. 08/649,240, filed May 14, 1996; 08/780,911, filed January 9, 1997; and 09/173,468 filed June 30, 1999, all included herein by reference.

The present invention provides compensating means to
20 correct for undesirable optical, electro-optical, and ambient light aberrations and for electronic anomalies, near the tile edge at the tile-to-tile seams, whether of vertical or horizontal orientation. Correction means are applied so that luminance and chromaticity of the tiles in
25 the display appear to be essentially uniform across the seams.

It is an object of this invention to provide compensating means to correct for the effects of LC cell gap variations. Cell gaps at the tile edge rarely match
30 those in the interior of the tile, thereby causing visible seams. Correction means are applied so that luminance and chromaticity of the display becomes visually continuous across the seams.

It is another object of this invention to provide compensating means for correcting for the effects induced by any other optical, electro-optical, mechanical, or structure related anomalies in tiled LC displays, including
5 those due to variations in the cell gap so that the seams become visually imperceptible. Chromaticity and luminance variations at the seams are corrected or smoothed over multiple pixels so that residual variations become
visually essentially uniform. Luminance and chromaticity
10 variations are thus suppressed and seams become visually imperceptible.

It is another object of this invention to correct for optical aberrations caused by artificial boundaries (seams) due to partitions of electronic scans, control and drivers,
15 whether occurring on tiled or monolithic display.

Another objective of this invention is the electronic correction of the brightness of all of the pixels across the interior of the tiles so that the display appears to be
of uniform light intensity or luminance. Such corrections
20 are made for each display assembly and are unique to that display.

SUMMARY OF THE INVENTION

In accordance with the present invention, there is provided compensating means to correct for visual
25 nonuniformities at edges of the tiles in tiled flat panel displays in order to produce a seamless appearance. Such a display comprises multiple tiles that are bonded together between continuous polarizers with an optical adhesive. The display may also have a cover plate which contains an
30 aperture mask, a screen, and a back plate containing another aperture mask. Tile edge nonuniformities include those due to LC cell gap variations and other seam related optical, electro-optical, ambient light, electronic, mechanical, and materials anomalies. Knowledge of these

anomalies is used to develop algorithms to correct for brightness and color imbalance near the edge of each tile. These algorithms alter the drive signals to sub-pixels located in close proximity to the seams and in the interior
5 regions of the tiles. Electronic video processing combined with previously acquired data from a correction data memory is used to implement the correction algorithms for the pixels adjacent to the seams and in the interior of the tiles in tiled, flat-panel, LC displays. The resulting
10 absolute, relative, or smoothing corrections made are unique to each tile and possibly unique to each edge pixel as well.

BRIEF DESCRIPTION OF THE DRAWINGS

A complete understanding of the present invention may
15 be obtained by reference to the accompanying drawings, when considered in conjunction with the subsequent, detailed description, in which:

FIGURE 1a illustrates a planar view of a tiled, flat-panel display constructed in accordance with techniques of
20 prior art;

FIGURE 1b is a schematic view of one of the tiles in a tiled, flat-panel display of FIGURE 1a (narrow seals inside and wide seals outside);

FIGURE 2 depicts a cross sectional view of an LCD tile
25 with spacers in the seals and spacers in the view area;

FIGURE 3 illustrates a topographical map of typical cell gap variations in a tiled, flat panel display;

FIGURE 4 depicts the calculated cell gap variation for an LC tile from the edge towards the interior of the tile;

FIGURE 5 illustrates a worst case measured normalized pixel luminance near the edge of an LC tile from the edge towards the center of the tile;

FIGURE 6 illustrates the relative optical transmission
5 for the three primary colors (R, G, and B sub-pixels) due to LC cell gap thickness variation in a tile;

FIGURE 7 depicts the normalized luminance in an LCD tile as a function of the ratio of the cell gap and wavelength for green blue and red light;

10 FIGURE 8 illustrates a typical difference between the normalized effective T-V curves (0-1 domain) of two sub-pixels as a function of the input signals specified in a 2^8 -bit range (0-255 domain);

15 FIGURE 9 depicts the deviation of the relative luminance of red, green, and blue sub-pixels from the nominal specified in terms of linear 2^8 bit input and output signals;

FIGURE 10a illustrates the relative brightness of the RGB sub-pixels near the edge of a typical LC tile;

20 FIGURE 10b illustrates the relative brightness of the RGB sub-pixels near the edge of a typical LC tile after being partially corrected;

25 FIGURE 10c illustrates the relative brightness of the RGB sub-pixels near the edge of a typical LC tile after being fully corrected;

FIGURE 11 is a block diagram level view of the implementation for correcting incoming pixel data using absolute or relative pixel matching for optical, electro-optical, ambient light, electronic, mechanical, and
30 materials anomalies and including the cell gap at the

seams; and

FIGURE 12 depicts the graphical determination of the correction to the input signal Δs of a sub-pixel given the desired correction for the normalized output luminance ΔL .

5 FIGURE 13 illustrates luminance lines scans across a seam in a tiled liquid crystal display before correction, after correction to match relative luminance levels, and after correction to smooth luminance levels.

For purposes of both clarity and brevity, like
10 elements and components will bear the same designations and numbering throughout the FIGURES.

DESCRIPTION OF THE PREFERRED EMBODIMENT

Generally speaking, this invention features electronic control means and a method for compensating or correcting
15 optical, electro-optical, electronic, mechanical and materials anomalies near the tile-to-tile seams, including those due to cell gap variations in tiled, flat-panel, LC displays. In addition, the invention features means and methods for correcting discoloration generally observed in
20 tiled, flat-panel, LC displays near the seams between adjacent tiles. Further, the invention provides means and methods for correcting brightness variations caused by such seams in tiled, flat-panel, LC displays. Corrections are done by matching pixel absolute or relative luminances or
25 smoothing spatial luminance differences.

Now referring to FIGURE 1a, a planar view of a color LC display 10 is shown. The display 10 consists of multiple tiles 11 separated by seams 110, each with an LC cell 12 (FIGURE 2), and two common external polarizers (not shown).
30 The four tile array is shown as an illustration only. Other tiling configurations are covered as well. Patterned color

filter layers 16 are placed and aligned in the active area 18 of the pixel window 20 to produce three primary colors. These color sub-pixels 22 are operated independently. The color filters 16 are typically chosen to be red, green and blue (or RGB). FIGURE 1b also shows the planar view of a tile 11 used in the display 10. The liquid crystal seal is wide along the outer edges 241 of the tile (heavy line) and narrow along the inner edges 242 (narrow line). Tile inner edges 242 are placed adjacent one another, forming seams 110 as shown in FIGURE 1a.

FIGURE 2 is a cross sectional view of a portion of an LC tile 11 used in a tiled and assembled display 10 (FIGURE 1). The vertical and lateral dimensions are drawn to a different scale in order to illustrate all essential details. The figure depicts the seal 26 and the spacer balls 28 within the seal 26 normally used in the fabrication of the LC cells 12. The two glass plates, 30 and 32 forming the LC cell 12, are bonded together around their respective perimeters under pressure, in order to maintain an accurate cell gap 33, or spacing between the inner surfaces of the two plates 30 and 32, as determined by the size of the spacer ball 28a located in the view area. The cell gap 33 near the inner seal edge 34 is determined by the spacer balls or spacer rods 35, dispersed in the seal adhesive 36, and the pressure, temperature and time parameters used in the tile bonding process. Generally a similar cell gap variations occur at the outer seal edge, but they do not usually give rise to visually disturbing artifacts, because pixels are not placed in close proximity to these outer seals. The structure and design of the tiles outside the pixel array greatly influences the cell gap and hence potentially induces variations in the cell gap as well. Examples of possible designs are described in co-pending patent U.S. application bearing serial number No. 09/386,921 (filed August 6, 1999).

Inherently then, there will be variation of the cell gap 33 in each tile 11 near the inner seal edge 34 due to the structure and process variables despite efforts to optimize the cell gap. This cell gap variation is well
5 behaved and smooth within a tile 11, but discontinuous from tile to tile. In addition, the tiled display assembly process, especially the attachment of the tiles with optical adhesive to cover and back plates, may alter the cell gap 33 as well.

10 Generally, a similar cell gap variation occurs at the outer seal edge, but this does not usually give rise to visually disturbing artifacts, because pixels are not placed in close proximity to these outer seals. It will be obvious to those skilled in the art that nominal cell gaps
15 may be controlled by one or more design features.

FIGURE 3 shows a typical topographical map of cell gap variations in an assembled, tiled display 10. In this example, each contour line 38 represents a cell gap variation of approximately $0.25 \mu\text{m}$ from the nominal cell
20 gap, typically approximately $5 \mu\text{m}$ for state-of-the-art AMLCD's. Island formation and relatively uniform edge effects are typical. Cell gap variations are usually largest at the inner seals because of their narrow width.

FIGURE 4 depicts the cell gap 33 variation profile
25 from the narrow seal 34 (FIGURE 2) towards the center of the tile as calculated from mechanical plate bending theory, well known to those skilled in the mechanical design arts, for a typical tile used in a tiled LCD assembly. The length scale on the horizontal axis is
30 measured in pixel pitches, typically on the order of one millimeter or less. Notice that the effects near the inner edge 34 penetrate a considerable distance into the interior of the tile 11. Brightness changes that result from the variation of the cell gap 33 impact the effective
35 transmission-voltage (T-V) curve of the sub-pixels. The LC

in the reduced cell gap 33 near the inner seal 34 is more responsive to voltage changes for drive voltage signals corresponding to mid-range brightness (gray scale between black and white) than a pixel with the nominal cell gap.

5 FIGURE 5 shows typical worst case measured experimental data for the variation in optical transmission through an LC tile 11 (relative luminance) from the inner edge seal 34 towards the interior of the tile 11. The length scale is given in pixel pitches. The optical
10 transmission is altered near the inner seal as a result of the cell gap 33 variations depicted in FIGURES 3 and 4.

 FIGURE 6 depicts the relative predicted optical transmission for red 40, green 42, and blue light 44 as a function of the cell gap 33. The transmission has been
15 normalized to the nominal case (cell gap of 5 μm in this illustration). Because both the cell gap and the wavelength of light affect the optical retardation through the LCD cell, the color balance will change spatially as the cell gap 33 varies. If the cell gap near the seal 34 is smaller
20 than in the interior of the tile 11, the seam area 34 will have a bluish cast, as evidenced by FIGURE 6 (enhanced blue). Similarly, if the cell gap 33 near the seal 34 is larger, the seam area 34 will have a brownish cast (enhanced red and green).

25 The spectrum of white light is altered as light passes through the cell gap, if it is not at its nominal value (5 μm in this illustration). The desired spectrum of light emanating from the display 10 is one where the three primary colors are balanced to the white point of the
30 display (i.e., equal drive signal values in the RGB color system). Therefore, the cell gap should ideally be set exactly at its nominal value at all pixel locations on the tiles (5 μm in this illustration). In practice, however, it is desirable for the cell gap to be as uniform as
35 possible, in order to produce the correct spectral output.

This is very difficult to achieve without the teachings of this invention.

Now referring to FIGURE 7, the typical simulated normalized luminances of the sub-pixels in an LCD cell are plotted as function of the optical length of the cell gap 5 33 for red 40, green 42 and blue 42 light with wavelengths of 612, 542, and 487 nm, respectively. The optical length was determined by the ratio of cell gap and the wavelength of light.

10 Therefore, it is desirable to correct pixels with slightly different effective T-V curves and other small optical, electro-optical, ambient light, electronic, mechanical, or materials anomalies close to the seams by changing the drive signals of the pixels in order to make 15 their appearance more uniform especially at the seams. Such corrections can either be done by matching the absolute luminance and chromaticity values defined in the nominal design or by matching the relative luminance and chromaticity values of one or multiple reference areas on 20 the display, preferably located in the interior of the tiles. Consequently, absolute or relative luminance levels of the sub-pixels close to the seams will be within the visual perception threshold of the nominal design or reference area specifications of pixels in the interior of 25 the tiles. Therefore, input data for each pixel according to this invention is replaced with new data from a correction procedure. This new data will be sent to commercially available column (data) driver chips connected electronically to the liquid-crystal display in the 30 conventional manner. Any correction data will be calculated in advance by applying the inverse of the transfer function to the domain of the input data, or input code range. The correction data may be different for each pixel or group of pixels of the display, thus accounting 35 for the difference in the characteristics of each pixel. A lookup table is one possible implementation for such a

correction algorithm. Unfortunately, such a correction scheme would result in a design that is so complex it could not be implemented economically for a large number of pixels using present state-of-the-art electronics.

5 Therefore, it is necessary to describe the deviations in the effective T-V curves of the sub-pixels in a manner that greatly reduces the amount of data that must be stored and accessed, as well as the amount of computation that must be performed for the video signal corrections during display
10 operation.

It is known that effective transmission-voltage (T-V) curves, or gamma curves, for AMLCDs, whether representative of the nominal design or differing from it because of reasons described above, are continuous functions.

15 Therefore, the differences between a deviant and the nominal effective T-V curve is not only a continuous function, but generally a rather smooth function on the scale of the least significant bit of the data driver. The difference between two typical effective T-V curves 48, one
20 shifted with respect to the other by a small amount but otherwise identical shape, shown in FIGURE 8 illustrates the smoothness of the difference in the effective T-V curves. This shift simulates a typical deviation of the effective T-V curve that leaves the white and black states
25 unchanged but greatly affects gray scale levels in between for each sub-pixel. The normalized linearized luminance differences for all primary colors are further illustrated in FIGURE 9, in which 8 bit nominal input signals to the red 50, green 52 and blue 54 sub-pixels produce output
30 luminance values for each primary color of a specific pixel. These luminance values differ from the nominal response represented by the dashed diagonal line 56 in this graph for each gray scale level and sub-pixel. In the
35 illustration of FIGURE 9 it is also assumed that the deviations of the effective T-V curves from the nominal vanish for white and black fields, an assumption that is usually justified because of the basic operation mechanism

of the LC cell. This is not a limitation of this invention, but rather a property of this illustration only. An effective T-V curve, or the difference between two effective T-V curves, can therefore be described or
5 approximated by dividing the domain of the function (or input code range) into pieces, and then describing each piece in a simple manner that is easy to compute in real time. Because of the smoothness and the generally small deviations from the nominal, one possibility is to describe
10 each piece by a linear function (piece-wise linear approximation). Then only the slope and offset would need to be stored to describe each piece. Consequently, the inverse transfer function (correction) for each piece would also be a linear function. Higher order polynomial
15 interpolation or spline functions well known in the field of numerical mathematics provide additional techniques for describing the pieces.

Because individual LCD tiles are made from multiple continuous sheets of material, the deviations in the cell
20 gap or other physical properties vary in a smooth and continuous manner compared to the pixel pitch (typically on the order of 1 mm or less). Therefore, these deviations may also be described using "contour mapping" or similar means to group small regions of pixels, or bands of pixels,
25 on a tile that have transfer functions whose differences compared to the nominal design are imperceptible to a human viewer. Then, the transfer function for all pixels within a region or band could refer to one copy of a transfer function that represents the entire region or band. The
30 corresponding inverse transfer functions could then be either simple or complex; however, since a number much smaller than the pixel count would be needed, such a correction scheme could be implemented using a practical amount of electronic hardware.

35 It is also known that effective T-V curves for AMLCDs, whether representative of the nominal design or deviating

from it because of reasons discussed above, have a very similar functional form. Therefore, a small number of reference T-V curves could be described in great detail, for example by using comprehensive lookup tables, as is
5 done to define the T-V curves of commercial LCD driver integrated circuit chips. This small number of effective T-V curves could be used to describe a much larger number of pixels by assigning labels to such T-V curves, and then developing a table of matching labels for the pixels. The
10 characteristics of each pixel would be measured and compared with the reference effective T-V curves, and the label of the closest matching T-V curve would be selected.

FIGURE 10a depicts the relative brightness values of RGB sub-pixels in a row of pixels from the inner seal 34 of
15 a tile 11 towards the interior of the tile. A uniform gray scale combination defines the input signals to the primary color sub-pixels. The inner seal 34 is positioned to the left of the pixel row 60 in this figure. The relative brightness values have been normalized into the usual 2^8
20 bit range, i.e. 0 - 255. The RGB signal values in the interior of the tile 11, 70/99/62 respectively, correspond to the nominal drive signal values for this sample gray scale field. No corrections have been applied to the pixels in FIGURE 10a. The corrections will be applied in
25 two steps: first considering hue and second brightness.

It is desirable to maintain the ratio of the relative brightness of blue to green and red to green over the entire tile 24 so that no discoloration will become
apparent to the viewer (hue correction). The cell gap 33,
30 or its variation, must therefore be measured directly or indirectly in order to apply any corrective action. The color corrected relative brightness values are illustrated in FIGURE 10b, where the relative brightness ratios between the primaries have been maintained approximately to the
35 precision of the least significant bit. Electronic controls in color displays typically allow for 8 bit or 256

levels of "gray" for each primary color. The relative blue brightness will be reduced in the sub-pixels 62 near the seal 34 using these controls. These corrections should be done to the frame buffer, (not shown) onto the frame data presented to the display 10. This eliminates tile edge related hue variations over the display 10.

However, these corrections may not restore the display to uniform luminance for uniform gray scale drive signals, because the sum of the relative brightness values varies from the inner edge towards the interior of the tile in the display 10. FIGURE 10c shows the relative brightness values of all the sub-pixels 64 from FIGURE 10b after they have been corrected for uniform luminance level everywhere. This correction can be achieved by applying a correction bit map image (not shown) to each incoming frame before the latter is sent to the data drivers (usually column) of the display 10. In the preferred embodiment, all pixel data will be changed in accordance with the teachings of this invention. Sub-pixel data is adjusted such that the spectral output from the display 10 is that of the desired hue and brightness uniformly across the entire pixel array of the display. In alternate embodiments, the inventive data corrections may be selectively applied.

Now referring to FIGURE 11, an illustration of the block diagram level implementation of the general correction procedure for 24 bit color is shown. Implementations for other color resolutions are similar and will be obvious to those skilled in the art. The incoming video data 70 is first temporarily stored in an input frame buffer memory 72. The video data is read from the input frame buffer 72 and correction data from the correction data memory 74 under the control of the pixel correction control unit 84 into the pixel data processor 76. The correction data memory 74 may be non-volatile memory, or volatile memory initialized to values stored in auxiliary non-volatile memory, or be initialized with values

calculated from values stored in non-volatile memory. This ensures that correction data is not lost, when the display is powered down. The appropriate corrections to the pixel video data are then applied by performing electronic pixel data processing using one or more processing units. Since both incoming and corrected video data for each sub-pixel are comprised of a single n-bit integer number (usually 8-bit), all pixel data processing only needs be done to n bit precision. Once pixel data has been corrected, it can be sent directly into the display 10 (FIGURE 1a). In an alternate embodiment, the pixel correction control unit 84 may be merged with the pixel data processing unit 76. Yet in another alternate embodiment, corrected pixel data may be collected in an output frame buffer memory 78 before it is sent to the display 10.

Sub-pixel data corrections may be accomplished in many ways. In one embodiment, sub-pixels are grouped according to their effective T-V curve responses and then each group is assigned a previously stored response function specific to that group. Groups may, for example, include interior area sub-pixels for each tile, and edge pixels for each inner and outer edge of each tile. As long as the number of groups is reasonable, the amount of data for the response functions that must be stored in the correction data memory will be acceptable. In another embodiment look up tables may be assigned to groups of sub-pixels. These tables would contain pixel data corrections using simple indexing schemes. Again, as long as the number of groups remains reasonable, the amount of data to be stored in the correction data memory will be acceptable.

In the simplest piecewise constant interpolation procedure with (s) segments, a single constant needs to be added to the sub-pixel data in the appropriate segment or:

$$\begin{aligned}r'(m,n) &= r(m,n) + \Delta r(m,n,ir) \\g'(m,n) &= g(m,n) + \Delta g(m,n,ig) \\b'(m,n) &= b(m,n) + \Delta b(m,n,ib)\end{aligned}$$

where the segment indices ir , ig , and ib are chosen to
5 satisfy

$$\begin{aligned}r(m,n,ir) &< r(m,n) < r(m,n,ir+1) \\g(m,n,ig) &< g(m,n) < g(m,n,ig+1) \\b(m,n,ib) &< b(m,n) < b(m,n,ib+1)\end{aligned}$$

and $1 \leq ir, ig, ib \leq s$. $r(m,n)$, $g(m,n)$, $b(m,n)$ and $r'(m,n)$,
10 $g'(m,n)$, $b'(m,n)$ denote the uncorrected and corrected sub-
pixel response, respectively. $\Delta r(m,n,ir)$, $\Delta g(m,n,ig)$ and
 $\Delta b(m,n,ib)$ denote the constants for the correction at each
sub-pixel and gray scale segment. Segment indices are
bounded by $1 \leq ir, ig, ib \leq s$ and pixel indices by $1 \leq m,n$
15 \leq resolution of screen. Above (m,n) denotes a pixel with
array indices m and n and ir , ig , and ib the segment index
for the red, green, and blue sub-pixels, respectively.
Note that the above equations do not include any cross
terms between the drive signals or corrections applied to
20 the sub-pixels. If such cross terms are desirable they can
be added at the expense of the complexity of the
implementation and additional storage capacity in the
correction data memory.

These equations can be applied to all pixels (m,n) ,
25 regions of pixels, sets of pixels, or individual pixels.
Since tiled displays normally have vertical, or horizontal,
or vertical and horizontal seams, pixels in close proximity
to the seams are easily identified with rectangular pixel
indices: one index is constant and the other varies along
30 the length of the seam. The implementation of these
equations in the pixel processor simply requires 8-bit
adders. The speed and number of adders required depends on
the video data rate and the number of pixels. Note that if
there is no pixel-to-pixel data dependency, parallel pixel

data processing can be used without restriction. Smoothing of sub-pixel corrections may introduce a modest amount data dependency. Therefore the throughput can in almost all cases be made to match the video data rate. The total
 5 memory capacity for storing the correction data is $m*n*3*s$ 8-bit words for the entire display, if all pixels are to be corrected. For example, for an SVGA display with a resolution of $(m,n) = (800*600)$ and 8 gray scale segments this gives 11.5M 8-bit words or 11 Mega-Bytes. For a tiled
 10 display with corrections applied only to k rows or columns on both sides of the seams, the storage requirement is reduced to a small fraction of this value. For example, for a 2x2 array of tiles with $k = 10$, there are only $2*k*(n+m)*3*s = 672K$ bytes to store.

15 Similarly in the piecewise linear case, a difference, a multiplication, and two additions shall be performed to the sub-pixel data in the appropriate segment. The equations now read:

$$\begin{aligned}
 r'(m,n) &= r(m,n) + \Delta r(m,n,ir) + rs(m,n,ir) * [xr(m,n) - xr(m,n,ir)] \\
 20 \quad g'(m,n) &= g(m,n) + \Delta g(m,n,ig) + gs(m,n,ig) * [xg(m,n) - xg(m,n,ig)] \\
 b'(m,n) &= b(m,n) + \Delta b(m,n,ib) + bs(m,n,ib) * [xb(m,n) - xb(m,n,ib)]
 \end{aligned}$$

where:

$$\begin{aligned}
 &r(m,n,ir) < r(m,n) < r(m,n,ir+1) \\
 &g(m,n,ig) < g(m,n) < g(m,n,ig+1) \\
 25 \quad &b(m,n,ib) < b(m,n) < b(m,n,ib+1)
 \end{aligned}$$

and $1 \leq ir, ig, ib \leq s$. $\Delta r(m,n,ir)$, $\Delta g(m,n,ig)$ and $\Delta b(m,n,ib)$ denote the constants; $rs(m,n,ir)$, $gs(m,n,ig)$, and $bs(m,n,ib)$ the slopes for the piecewise linear corrections; $xr(m,n)$, $xg(m,n)$, and $xb(m,n)$ the input
 30 signals for the current sub-pixel; $xr(m,n,ir)$, $xg(m,n,ig)$, and $xb(m,n,ib)$ the input signals for the current gray scale segment and for each sub-pixel and gray scale segment. The

implementation of these equations in the pixel processor simply requires 8-bit adders and multipliers. Parallel processing can again be used, if desired. The speed and number of the required adders and multipliers depends on
5 the video data rate and the number of pixels. The total memory capacity for storing the correction data is $m*n*3*s*2$ 8-bit words for the entire display, if all pixels are to be corrected. For example, for an SVGA display with a resolution of $(m,n) = (800*600)$ and 8 segments this gives
10 23M 8-bit words or 23 Mega-Bytes. For a tiled display with corrections applied only to k rows or columns on both sides of the seams, the storage requirement reduces to a small fraction of this value. For example, for a $2*2$ array of tiles with $k = 10$, there are $2*k*(n+m)*3*s*2 = 1.34M$ bytes
15 to store.

As before the above equations do not include any cross terms between the drive signals or corrections applied to the sub-pixels. If such cross terms are desirable they can be added at the expense of the complexity of the
20 implementation and additional storage capacity of the correction data memory. Higher order piecewise interpolation procedures may be applied in a similar fashion by performing 8-bit arithmetic operations. Additional storage capacity in the correction data memory
25 needs to be provided for each new parameter. The estimation of the capacity can be done in a straightforward manner by extending the formulas show above.

Irrespective of the specific correction algorithm used, the correction data must be acquired. This can be
30 done by measuring the luminance of each sub-pixel under gray scale excitation for one or multiple levels in each segment. The actual measurement can be done by scanning over the pixel array of the display using a luminance meter over individual pixels, or alternatively using a camera,
35 such as a charge coupled device (CCD) camera, that records the entire array, or substantial regions of the pixel

array, in parallel. In the former case the acceptance angle of the luminance detector must be small enough so that adjacent pixels don't contribute to the recorded luminance for the pixel being measured. In the latter case
 5 the camera may have to be carefully aligned with display pixel array such that there preferably is a simple correspondence between the display pixels and the camera image. A one-to-one correspondence is preferred, but other arrangements can be made to work as well. Irrespective of
 10 the measurement method used, the result is a set of measured luminance values $r_m(m,n,ir,ur)$, $g_m(m,n,ig,ug)$, $b_m(m,n,ib,ub)$ for each measured pixel index (m,n) , segment index (ir,ig,ib) , and gray scale index (ur,ug,ub) . The correction data can then be computed from the difference
 15 between the measured data and nominal data for each pixel to be corrected. For example, for the piecewise constant correction procedure the correction data for each sub-pixel and gray scale segment is given by

$$\begin{aligned} \Delta r(m,n,ir) &= r_n(m,n,ir,ur) - r_m(m,n,ir,ur) \\ \Delta g(m,n,ig) &= g_n(m,n,ig,ug) - g_m(m,n,ig,ug) \\ \Delta b(m,n,ib) &= b_n(m,n,ib,ub) - b_m(m,n,ib,ub), \end{aligned}$$

where $r_n(m,n,ir,ur)$, $g_n(m,n,ig,ug)$, and $b_n(m,n,ib,ub)$ denote the nominal luminance value for this sub-pixel and gray scale segment. The extension of this procedure to
 25 other interpolation schemes, including piecewise linear and higher order methods, is straightforward and well known to those skilled in the art and will not be explicitly explained here.

Instead of determining the correction data from the
 30 measured effective T-V curves, in some cases it may be preferable to measure the physical characteristics of the edge effect directly and then compute the correction data from this knowledge. As an illustration of this, consider a cell gap change close to the seam that could be measured
 35 using well known optical techniques. The cell gap data as

a function of location can then be translated into T-V curve correction data.

The remaining issue is to find a way to change the input data given to the sub-pixels such that the
5 corrections specified above are realized. This is simply given by the inverse function of the effective T-V curve of the sub-pixel in question. The relationship between the required luminance correction and the corresponding input data bits is illustrated in FIGURE 12 graphically for a
10 normally white LCD. The input data correction ΔS is simply directly given by the required normalized luminance correction ΔL . Mathematically, if an analytical representation for the effective T-V curve $L(S)$ is available, ΔS can be immediately obtained from the inverse
15 function L^{-1} via $\Delta S = L^{-1}(L+\Delta L) - L^{-1}(L)$. If a numerical representation (S_i, L_i) for the effective T-V curve is known, ΔS is determined by the closest mesh point S_k that corresponds to ΔL in the table. Both negative and positive corrections can be specified in this fashion but the
20 resulting corrected normalized sub-pixel luminances must be contained in the interval $(0,1)$. The smallest corrections that can be applied in the most sensitive steep region of the effective T-V curve (maximum magnitude of the slope) determines the resolution of this correction procedure.
25 For a linear T-V curve and uniform allocation of bits the smallest correction is given by the least significant bit, i.e. $1:2^n$. For non-linear effective T-V curves it will depend on the number of bits and the length of the flat regions of the effective T-V curve and generally be
30 different from $1:2^n$. The resolution of the correction procedure can be improved by going to higher resolution digital-to-analog converters (DACs) within the data drivers or by allocating more bits to the steep region of the effective T-V curve in a non-uniform fashion. The
35 resolution of the correction procedure can also be enhanced by using time-domain dithering, i.e., averaging over different correction signals applied during successive

frames, thus producing the desired correction at time domain averages. This technique is frequently used to enhance the color resolution of the flat panel plasma displays, for which it is difficult to fabricate the required high voltage driver IC's at the desired position.

The correction procedures described above may lead to sharply varying corrections from pixel to pixel. Such corrections may also be influenced by measurement noise as well. Unless complete grayscale uniformity within the detection threshold of the human eye is achieved for each sub-pixel, visually objectionable artificial patterns may results. Such patterns can be removed, if high spatial frequency components are removed using signal processing techniques. In such cases it will be advantageous to filter the measured pixel or sub-pixel luminance data or the corrected data using suitable two-dimensional video signal filtering algorithms. Examples of desired algorithms well known in the field of digital signal processing include windowing, analog filtering, digital filtering, low pass filtering, band pass filtering, fast Fourier transform, and wavelets. Other filtering or smoothing techniques may be used as well.

In some cases it may not be desirable to try to uniformly match neither the absolute or relative luminance and chromaticity levels close to the seams but rather use smoothing or blending techniques to suppress any abrupt changes and sharp gradients below the perceptual threshold levels of the human vision system. This has been illustrated in FIGURE 13. A luminance line scan for a gray scale field across a seam has been drawn for four cases: (a) the uncorrected display 110; (b) a display corrected to match the relative luminance levels in the interior of the tiles 112; (c) a display with corrections smoothed across the seam such that the discrimination threshold for the luminance gradient remain below the visual detection threshold 114, and (d) a display corrected to match

absolute level across the seam 116. The curves have been shifted with respect to each others in order to show their difference more clearly. Smoothing can be performed in two fundamentally different ways: (a) in static sense, if the
5 smoothing procedure remains the same over the time of use of the display, or (b) in the dynamic sense, if smoothing is done at the time of displaying the each video image.

Static smoothing may be applied to the measured pixel data or the correction data using mathematical smoothing
10 techniques well known to those skilled in the art of numerical mathematics and/or signal processing. Therefore static smoothing simply becomes one of the steps in the algorithm that determines the sub-pixel correction data stored in the correction data memory. Static smoothing
15 does not introduce any real time data dependencies and therefore pixel data processing can be executed in parallel, if desired. Static smoothing does not change the electronic implementation of video data correction procedure. It is fully compatible with the types of
20 architectures shown in FIGURE 11.

On the other hand, dynamic smoothing during real time display operation introduces real data dependencies. The range of this dependency is determined on the specific dynamic smoothing algorithm that is adopted. Dynamic
25 smoothing of non-uniformities introduced by optical, electro-optical, ambient light, electronic, mechanical, or materials anomalies, may be done by operating on the corrected video data in the output frame buffer memory 78. Dynamic smoothing requires edge pattern detection in order
30 to discriminate against sharp details in the actual video data. However, since edges are static with a fixed pattern and a characteristic signature, they can be easily distinguished from patterns in the actual video data. Many electronic implementations of dynamic smoothing are
35 possible using custom designed hardware and general purpose digital signal processing (DSP) chips. Smoothing

algorithms, such as moving averages, are inherent parallel, because pixel data interactions are local. Dynamic compared to static smoothing is much more complex to implement, but allows for correction of time variable edge related anomalies, such as those arising from display heating or differential aging.

Consider finally the full procedure for correcting a given tiled display for optical, electro-optical, ambient light, cell, gap, mechanical, or materials anomalies at the tile edges. The piecewise linear interpolation method has been chosen in this procedure. The display is assumed to be divided into interior regions of the tiles, each of which is treated as one object, and individual pixels in predetermined regions in close proximity seams, each of which is treated as one object in the correction procedure. This example is chosen to illustrate how the teachings of this invention are related to each other and how they would be used rather than exhaust all possible algorithms and methods that have been described above. The full procedure will be described in two sub-procedures. The first one will determine corrections for the interior regions of the tiles and the second for the individual pixels in the seam regions. Both sub-procedures are as logically connected steps.

25 Sub-Procedure 1: Corrections for Interior Regions

- Step 1 Select new primary color
- Step 2 Select new gray scale segment for current primary color
- Step 3 Display primary current gray scale image
- 30 Step 4 Measure and store primary color gray scale image map over entire pixel array
- Step 5 Filter high spatial frequency components from image map, if desired
- Step 6 Determine tile specific correction data constants
- 35 for current gray scale segment and primary color that match interior regions of all tiles to the

same absolute or relative luminance level

Step 7 Go to step 2. If all gray scale segments are done, go to step 8

Step 8 Determine tile specific correction data slopes
5 for gray scale segments for current primary color. If necessary display and measure new image map.

Step 9 Go to step 1. If all primary colors are done, go to step 10

10 Step 10 Store all tile interior specific gray scale segment and primary specific correction data, constants and slopes, in a format appropriate for correction data storage memory and pixel data processing.

15 Sub-Procedure 2: Corrections for Edge Pixels

Step 1 Select new primary color

Step 2 Select new gray scale segment for primary color

Step 3 Display primary color gray scale image for constant correction

20 Step 4 Measure and store primary color gray scale image over entire pixel array with correction data from sub-procedure 1 applied to interior regions of tiles

Step 5 Filter high spatial frequency components from
25 image map, if desired

Step 6 Select new sub-pixel in seam region

Step 7 Determine sub-pixel specific correction data constant for current sub-pixel, gray scale segment and primary color

30 Step 8 Go to step 6. If all sub-pixels done, go to step 9

Step 9 Display primary color gray scale image for slope correction

Step 10 Measure and store primary color gray scale image
35 over entire pixel array with correction data from sub-procedure 1 applied to all interior regions

- of tiles and constant gray scale correction applied to all sub-pixels in seam regions
- Step 11 Filter high spatial frequency components from image map, if desired
- 5 Step 12 Select new sub-pixel in seam region
- Step 13 Determine sub-pixel specific correction data slope for current sub-pixel, gray scale segment and primary color
- Step 14 Go to step 12. If all sub-pixels done, go to step
10 15
- Step 15 Apply smoothing algorithm to sub-pixel correction data (constant, slope) for current gray scale segment and primary color
- Step 16 Go to step 2. If all gray scale segments done, go
15 to step 17
- Step 17 Go to step 1. If all primary colors done, go to step 18
- Step 18 Store all seam region sub-pixel, gray scale
20 segment, and primary color specific correction data, constants and slopes, in a format appropriate for correction data storage memory and pixel data processing.

In the above procedures a specific weighted response curve is assumed to describe the effective T-V curve. If
25 the viewer wants to switch the chosen weighted response curve to a different one, for example because of psychophysiological reasons or the chromaticity content of the images to be displayed, the entire procedure can be simply repeated. However, this involves quite a bit of
30 additional work. Instead, the correction data for one weighted response curve can be directly transformed for the other response curve mathematically. This is possible because the impact of the edge effects associated with the tiled display have already been fully characterized and
35 therefore uniquely determine the other correction data set.

Additional designs can be produced for specific display purposes or to match other liquid-crystal designs and sub-pixel color filters. Still additional designs can be formulated by those skilled in the art using the principles taught in this invention.

Although the correction algorithms in this invention have been described in the context of tiled liquid crystal displays, they can in some cases be applied to correct for similar anomalies in other display, such as monolithic LCD's with no seams or tiled LC displays expressly built to show seams. The latter includes video walls. The extension the teachings of this inventions to such other displays can easily be formulated by those skilled in the art.

Since other modifications and changes varied to fit particular operating requirements and environments will be apparent to those skilled in the art, the invention is not considered limited to the examples chosen for purposes of disclosure, and covers all changes and modifications which do not constitute departures from the true spirit and scope of this invention.

Having thus described the invention, what is desired to be protected by Letters Patent is presented in the subsequently appended claims.

25 What is claimed is:

1 1. A tiled, flat-panel liquid crystal display (LCD)
2 having compensation for edge effects so that the display
3 has visually imperceptible seams, comprising:

4 a) first and second LCD display tiles arranged
5 adjacent one another with a seam therebetween,
6 each of said tiles having an edge proximate said
7 seam and an interior region with a plurality of
8 pixels disposed therein, each of said pixels
9 being adapted to modify transmitted light upon
10 stimulation by respective pixel stimulation
11 signals; and

12 b) means for selectively altering said pixel
13 stimulation signals responsive to said edge
14 effects, whereby variations in luminance and
15 chromaticity of said modified, transmitted light
16 from said pixels are reduced below a
17 predetermined perceptual threshold.

1 2. The tiled, flat-panel LCD as recited in claim 1,
2 wherein said pixels comprise sub-pixels, and said pixel
3 stimulation signals comprise sub-pixel stimulation signals,
4 each of said sub-pixels being adapted to transmit light
5 having a distinct, predetermined chromaticity and luminance
6 upon stimulation by a corresponding sub-pixel stimulation
7 signal, and said means for selectively altering said pixel
8 stimulation signals comprises means for altering said sub-
9 pixel stimulation signals.

1 3. The tiled, flat-panel LCD as recited in claim 2,
2 wherein each of said pixels comprises a primary color sub-
3 pixel.

1 4. The tiled, flat-panel LCD as recited in claim 3,
2 wherein said primary color sub-pixel comprises red, green
3 and blue sub-pixels.

1 5. The tiled, flat-panel LCD as recited in claim 2,
2 wherein said means for selectively altering said sub-pixel
3 stimulation signals is adapted to reduce variations in
4 luminance and chromaticity of said modified, transmitted
5 light across a predetermined region of said display below a
6 discernable threshold.

1 6. The tiled, flat-panel LCD as recited in claim 5,
2 wherein said variations in luminance and chromaticity of
3 said modified, transmitted light comprise at least one from
4 the group: abrupt variations and gradual variations.

1 7. The tiled, flat-panel LCD as recited in claim 6,
2 wherein said means for selectively altering said sub-pixel
3 stimulation signals is applied to individual sub-pixels.

1 8. The tiled, flat-panel LCD as recited in claim 6,
2 wherein said means for selectively altering said sub-pixel
3 stimulation signals is applied to a predetermined subset of
4 said sub-pixels.

1 9. The tiled, flat-panel LCD as recited in claim 8,
2 wherein said predetermined subset of said pixels comprises
3 pixels having substantially identical light output
4 characteristics.

1 10. The tiled, flat-panel LCD as recited in claim 9,
2 wherein said light output characteristics are described by
3 effective T-V curves.

1 11. The tiled, flat-panel LCD as recited in claim 8,
2 wherein said means for selectively altering said sub-pixel
3 stimulation signals is adapted to reduce variations in
4 luminance and chromaticity in a predetermined subset of
5 said pixels below a predetermined, discernable threshold.

1 12. The tiled, flat-panel LCD as recited in claim 11,
2 wherein said predetermined subset of said pixels comprises
3 pixels in edge regions proximate said seam between said
4 tiles.

1 13. The tiled, flat-panel LCD as recited in claim 6,
2 wherein said means for selectively altering said sub-pixel
3 stimulation signals responsive to said edge effects
4 comprises means for smoothing said sub-pixel stimulation
5 signals, whereby abrupt variations are reduced to gradual
6 variations below a predetermined perceptual threshold.

1 14. The tiled, flat-panel LCD as recited in claim 13,
2 wherein said achieved variation in luminance and
3 chromaticity proximate said seam renders said seam visually
4 imperceptible to a viewer at a predetermined position
5 relative to said LCD and under predetermined ambient light
6 conditions.

1 15. A method for correcting luminance and
2 chromaticity variations caused by tile edge effects in
3 tiled, flat-panel liquid crystal displays (LCDs), the steps
4 comprising:

5 a) providing at least two LCD tiles arranged
6 adjacent one another with a seam therebetween,
7 each of said tiles having an edge proximate said
8 seam and an interior region with a plurality of
9 pixels disposed therein, said pixels being
10 adapted to modify transmitted light upon
11 stimulation by respective pixel stimulation
12 signals;

13 b) mapping at least one region of said pixels in
14 said LCD tiles, each of said pixels in said
15 region having a similar effective T-V curve in an
16 LCD tile;

17 c) determining a transfer function for said mapped
18 region to change one of said effective T-V curves
19 to a predetermined, reference effective T-V
20 curve; and

21 d) applying an inverse of said transfer function to
22 said pixel stimulation signals so that said
23 pixels in said region appear to exhibit said
24 predetermined, reference effective T-V curve.

1 16. The method for correcting luminance and
2 chromaticity variations in tiled, flat-panel LCDs as
3 recited in claim 15: wherein said pixels comprise sub-
4 pixels; said mapping step (a) comprises mapping regions of
5 said sub-pixels, each having a similar effective T-V curve,
6 said pixel stimulation signals comprising sub-pixel
7 stimulation signals; and said applying an inverse transfer
8 function step (c) further comprises applying an inverse of
9 said transfer function to said sub-pixel stimulation
10 signals.

1 17. The method for correcting luminance and
2 chromaticity variations in tiled, flat-panel LCDs as
3 recited in claim 16, wherein said inverse transfer function
4 comprises a look-up table.

1 18. The method for correcting luminance and
2 chromaticity variations in tiled, flat-panel LCDs as
3 recited in claim 16, wherein said inverse transfer function
4 comprises piece-wise interpolation.

1 19. The method for correcting luminance and
2 chromaticity variations in tiled, flat-panel LCDs as
3 recited in claim 16, wherein said inverse transfer function
4 is constructed using mathematical interpolation techniques
5 based on at least one of: constants, slopes and higher-
6 order terms.

1 20. The method for correcting luminance and
2 chromaticity variations in tiled, flat-panel LCDs as
3 recited in claim 17, wherein said look-up table comprises
4 at least one of the group of slope data and offset data.

1 21. The method for correcting luminance and
2 chromaticity variations in tiled, flat-panel LCDs as
3 recited in claim 18, wherein said mapping step (b)
4 comprises producing a contour map.

1 22. The method for correcting luminance and
2 chromaticity variations in tiled, flat-panel LCDs as
3 recited in claim 21, wherein said contour map represents
4 regions of sub-pixels each having a substantially identical
5 effective T-V curve.

1 23. The method for correcting luminance and
2 chromaticity variations in tiled, flat-panel LCDs as
3 recited in claim 22, wherein said mapping step (b)
4 comprises the sub-steps of:

5 i) measuring edge effects at a plurality of
6 locations in an LCD tile; and

7 ii) determining effective T-V curves representative
8 of said measured cell gaps.

1 24. The method for correcting luminance and
2 chromaticity variations in tiled, flat-panel LCDs as
3 recited in claim 22, wherein said determining transfer
4 function step (c) comprises determining a transfer function
5 for sub-pixels for a mapped region.

1 25. The method for correcting luminance and
2 chromaticity variations in tiled, flat-panel LCDs as
3 recited in claim 24, wherein said transfer function is
4 selectively applied to said sub-pixels dependent upon said
5 primary colors thereof.

1 26. A method for correcting luminance and
2 chromaticity variations caused by optical aberrations near
3 an edge of a tile in tiled, flat-panel liquid crystal
4 displays (LCDs), the steps comprising:

- 5 a) identifying an optical aberration affecting sub-
6 pixels proximate an edge of an LCD tile, each of
7 said sub-pixels having an effective T-V curve
8 associated therewith;
- 9 b) determining a transfer function for said affected
10 sub-pixels to change one of said effective T-V
11 curves to a predetermined, reference effective T-
12 V curve; and
- 13 c) applying an inverse of said transfer function to
14 said affected sub-pixels so that each pixel
15 appears to have substantially said predetermined,
16 reference effective T-V curve.

1 27. The method for correcting luminance and
2 chromaticity variations in tiled, flat-panel LCDs as
3 recited in claim 26, wherein said inverse transfer function
4 comprises a look-up table.

1 28. The method for correcting luminance and
2 chromaticity variations in tiled, flat-panel LCDs as
3 recited in claim 27, wherein said look-up table comprises
4 at least one of the group of slope data and offset data.

1 29. The method for correcting luminance and
2 chromaticity variations in tiled, flat-panel LCDs as
3 recited in claim 28, the steps further comprising: (d)
4 producing a contour map.

1 30. A method for correcting luminance and
2 chromaticity variations in tiled, flat-panel LCDs as
3 recited in claim 29, wherein said contour map represents
4 regions of sub-pixels each having a substantially identical
5 effective T-V curve.

1 31. A method for correcting luminance and
2 chromaticity variations in tiled, flat-panel LCDs as
3 recited in claim 30, wherein said producing a contour map
4 step (d) comprises the sub-steps of:

5 i) measuring variations of at least one of
6 chromaticity and luminance caused by optical
7 aberrations at a plurality of locations in said
8 LCD tile; and

9 ii) determining effective T-V curves representative
10 of sub-pixels at said plurality of locations.

1 32. A method for correcting luminance and
2 chromaticity variations in tiled, flat-panel LCDs as
3 recited in claim 30, wherein said pixels comprise sub-
4 pixels, each transmitting a predetermined, primary color.

1 33. A method for correcting luminance and
2 chromaticity variations in tiled, flat-panel LCDs as
3 recited in claim 32, wherein said determining transfer
4 function step (b) comprises determining a transfer function
5 for sub-pixels for a mapped region dependent upon said
6 primary color thereof.

1 34. A method for correcting luminance and
2 chromaticity variations in tiled, flat-panel liquid crystal
3 displays (LCDs) as recited in claim 33, said transfer
4 function is selectively applied to said sub-pixels
5 dependent upon said primary colors thereof.

1 35. A method for producing a tiled, flat-panel LCD
2 having substantially uniform luminance and chromaticity and
3 having visually imperceptible seams, the steps comprising:

- 4 a) arranging a plurality of individual display tiles
5 with seams therebetween, each of said tiles
6 comprising an array of pixels, said pixels
7 comprising sub-pixels, each of said sub-pixels
8 comprising a liquid crystal cell having a
9 respective effective T-V curve;
- 10 b) providing driver means for presenting sub-pixel
11 stimulation signals to said sub-pixels, said
12 driver means comprising a plurality of driver
13 chips, each of said plurality of driver chips
14 being operatively connected to a predetermined
15 group of said sub-pixels;
- 16 c) modifying the effective T-V curve of each of said
17 sub-pixels and associated driver chips in a
18 predetermined manner;
- 19 d) adjusting the luminance and chromaticity of sub-
20 pixels disposed at interior regions of said
21 individual display tiles to a predetermined
22 level; and
- 23 e) adjusting the luminance and chromaticity of sub-
24 pixels proximate said seams substantially to said
25 predetermined grey scale excitation level.

1 36. The method for producing a tiled, flat-panel LCD
2 display as recited in claim 35, wherein said modifying step
3 (c) comprises at least one from the operations of
4 linearizing and creating a weighted responses.

1 37. The method for producing a tiled, flat-panel LCD
2 display as recited in claim 35, wherein said adjusting step
3 (e) comprises blending.

1 38. The method for producing a tiled, flat-panel LCD
2 as recited in claim 35, wherein said predetermined level
3 comprises an externally chosen reference level.

1 39. The method for producing a tiled, flat-panel LCD
2 as recited in claim 35, wherein said predetermined level
3 comprises a relative level dependant upon at least one
4 operational parameter of at least one of said plurality of
5 individual display tiles.

1 40. The method for producing a tiled, flat-panel LCD
2 display having substantially uniform luminance and
3 chromaticity and having visually imperceptible seams as
4 recited in claim 37, wherein said predetermined level
5 comprises a plurality of predetermined levels, each which
6 being associated with one of said plurality of individual
7 display tiles.

1 41. The method for producing a tiled, flat-panel LCD
2 display having substantially uniform luminance and
3 chromaticity and having visually imperceptible seams as
4 recited in claim 40, wherein said blending process results
5 in luminance and chromaticity variations below a
6 predetermined perceptual threshold between any two of said
7 plurality of individual tiles.

1 42. The method for producing a tiled, flat-panel LCD
2 display having substantially uniform luminance and
3 chromaticity and having visually imperceptible seams as
4 recited in claim 35, wherein said driver chips comprise
5 digital-to-analog converters (DACs) and said modifying step
6 (c) comprises setting DAC voltage values at predetermined
7 points in a non-linear response curve of said driver chips
8 to provide an inverse response function of a response curve
9 of said liquid crystal cell whereby said effective T-V
10 curve associated with said liquid crystal cell is made
11 substantially linear.

1 43. A method for producing a tiled, flat-panel LCD
2 display having substantially uniform luminance and
3 chromaticity and having visually imperceptible seams, the
4 steps comprising:

5 a) arranging a plurality of individual display tiles
6 with seams therebetween, each of said tiles
7 comprising an array of pixels, said pixels
8 comprising sub-pixels for transmitting a
9 predetermined primary color upon application of a
10 sub-pixel stimulation signal;

11 b) adjusting luminance and chromaticity of said sub-
12 pixels located at interior regions of said
13 individual tiles to a first, predetermined level;

14 c) blending said first and said second predetermined
15 levels whereby differences in luminance and
16 chromaticity between said interior region and
17 said seams are reduced below a predetermined
18 perceptual threshold.

1 44. The method for producing a tiled, flat-panel LCD
2 display having substantially uniform luminance and
3 chromaticity and having visually imperceptible seams as
4 recited in claim 43, the steps further comprising:

5 d) adjusting luminance and chromaticity of said sub-
6 pixels located proximate intersections of said
7 seams.

1 45. The method for producing a tiled, flat-panel LCD
2 display having substantially uniform luminance and
3 chromaticity as recited in claim 44, the steps further
4 comprising:

5 e) adjusting luminance and chromaticity of said sub-
6 pixels located proximate said seams between said
7 individual tiles to a second, predetermined
8 level.

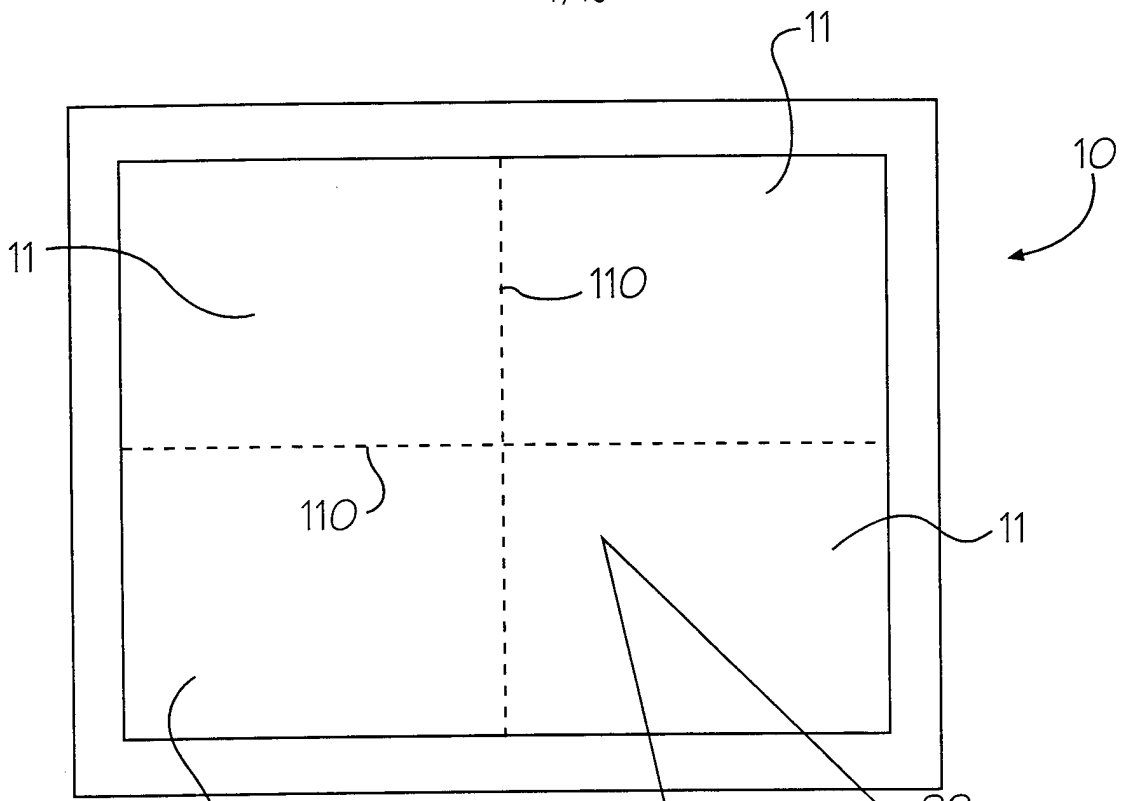

Figure 1a

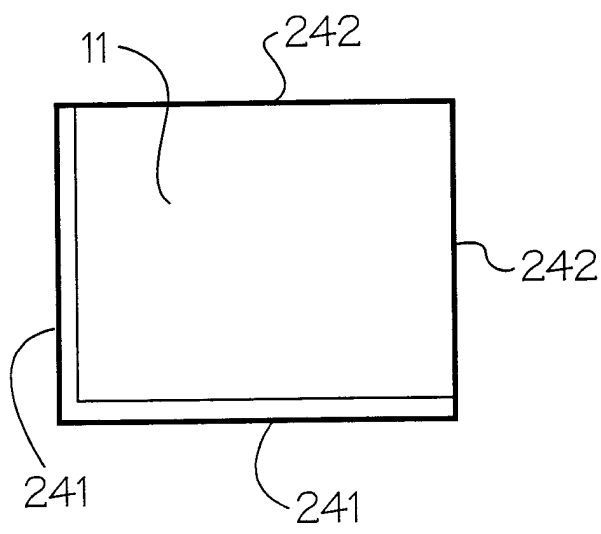

Figure 1b

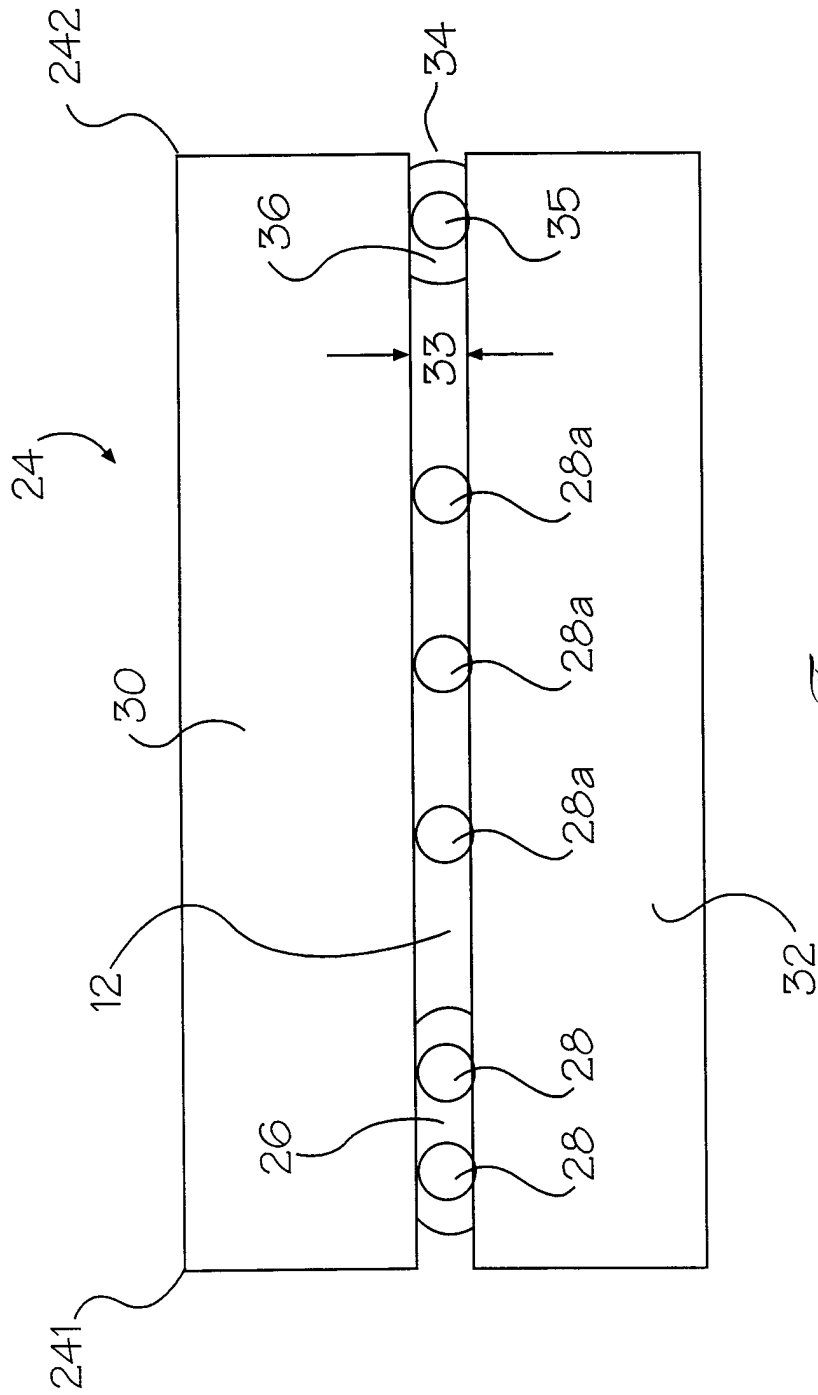

Figure 2

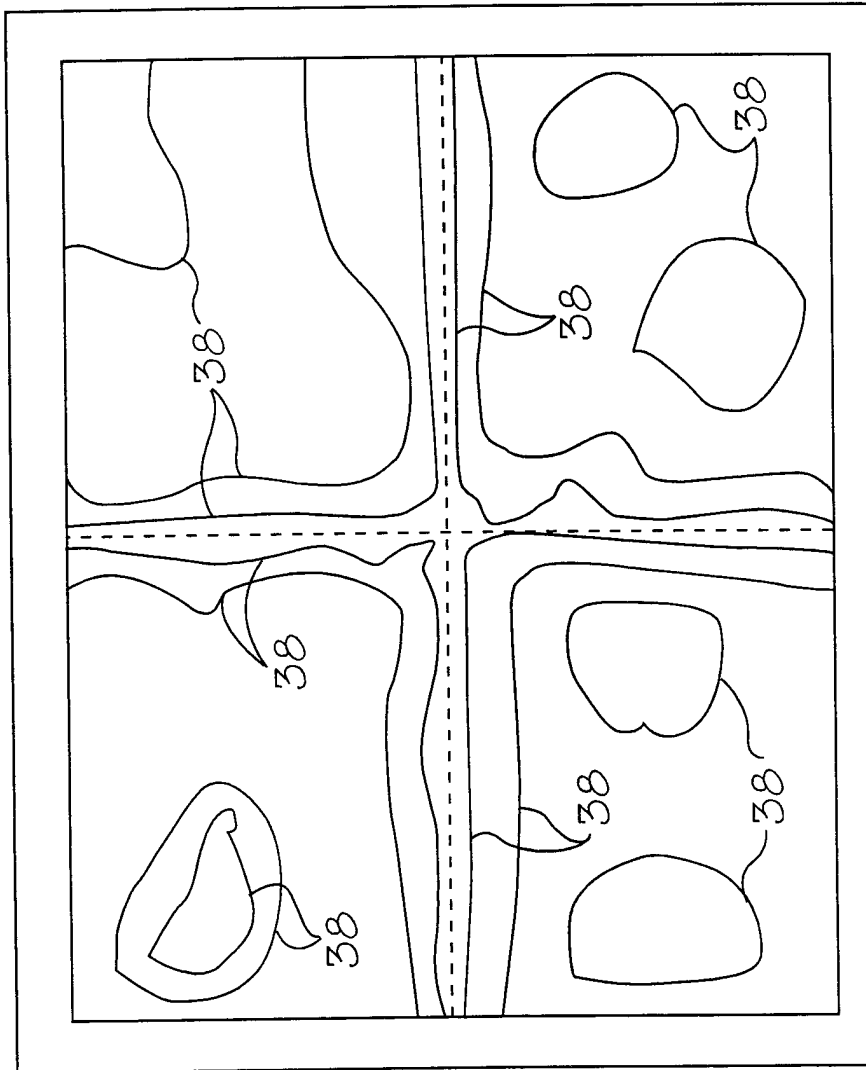

Figure 3

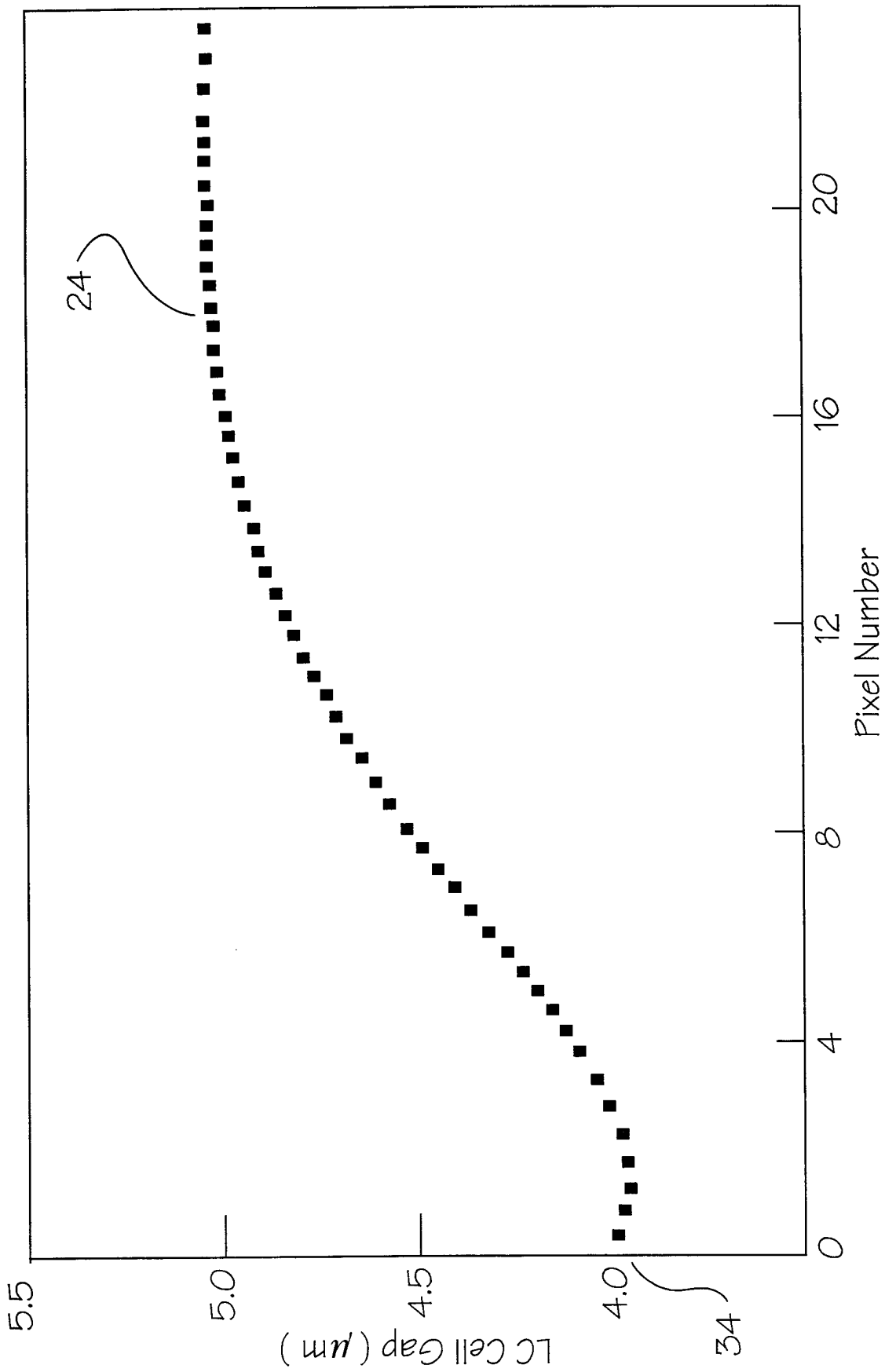

Figure 4

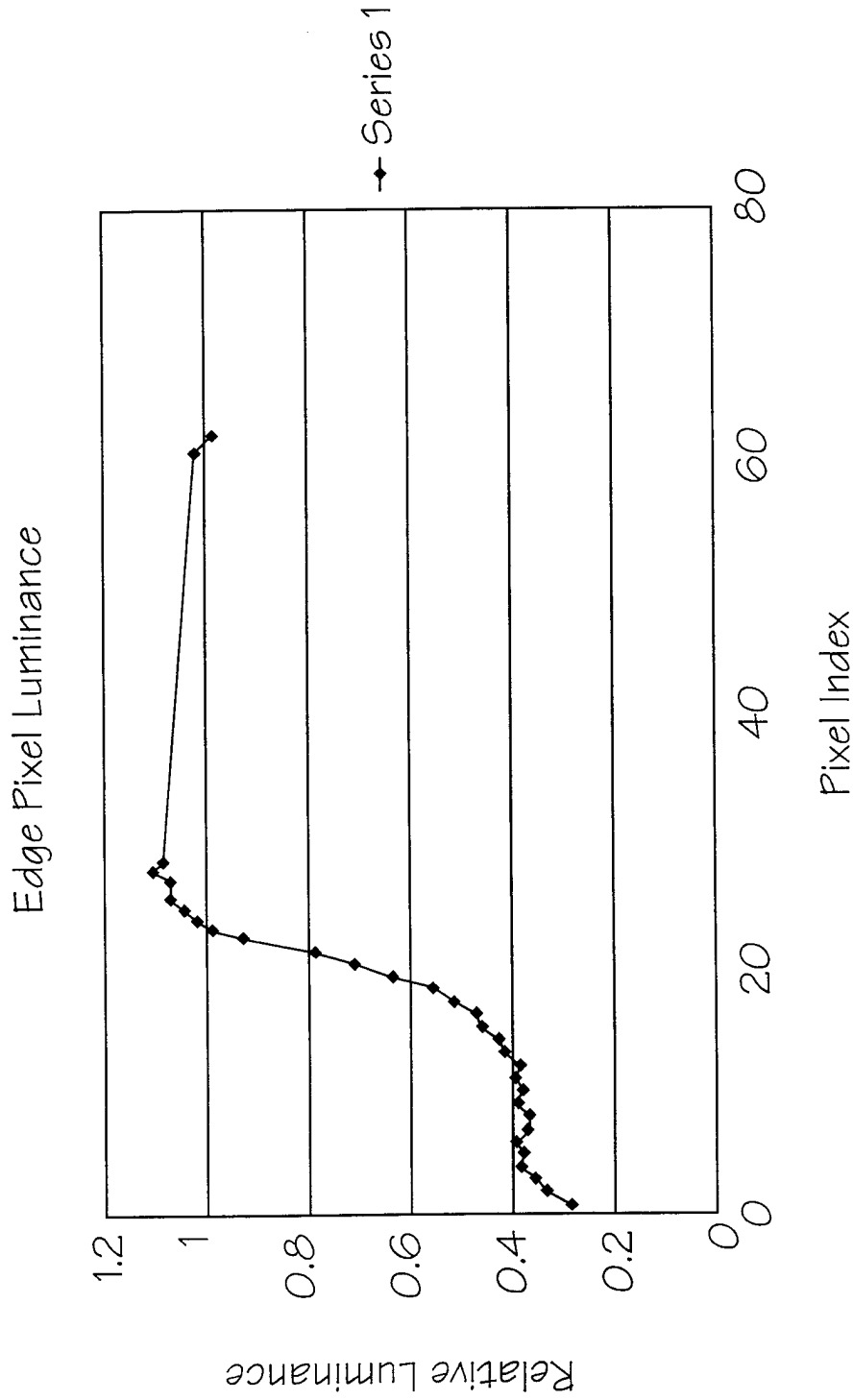

Figure 5

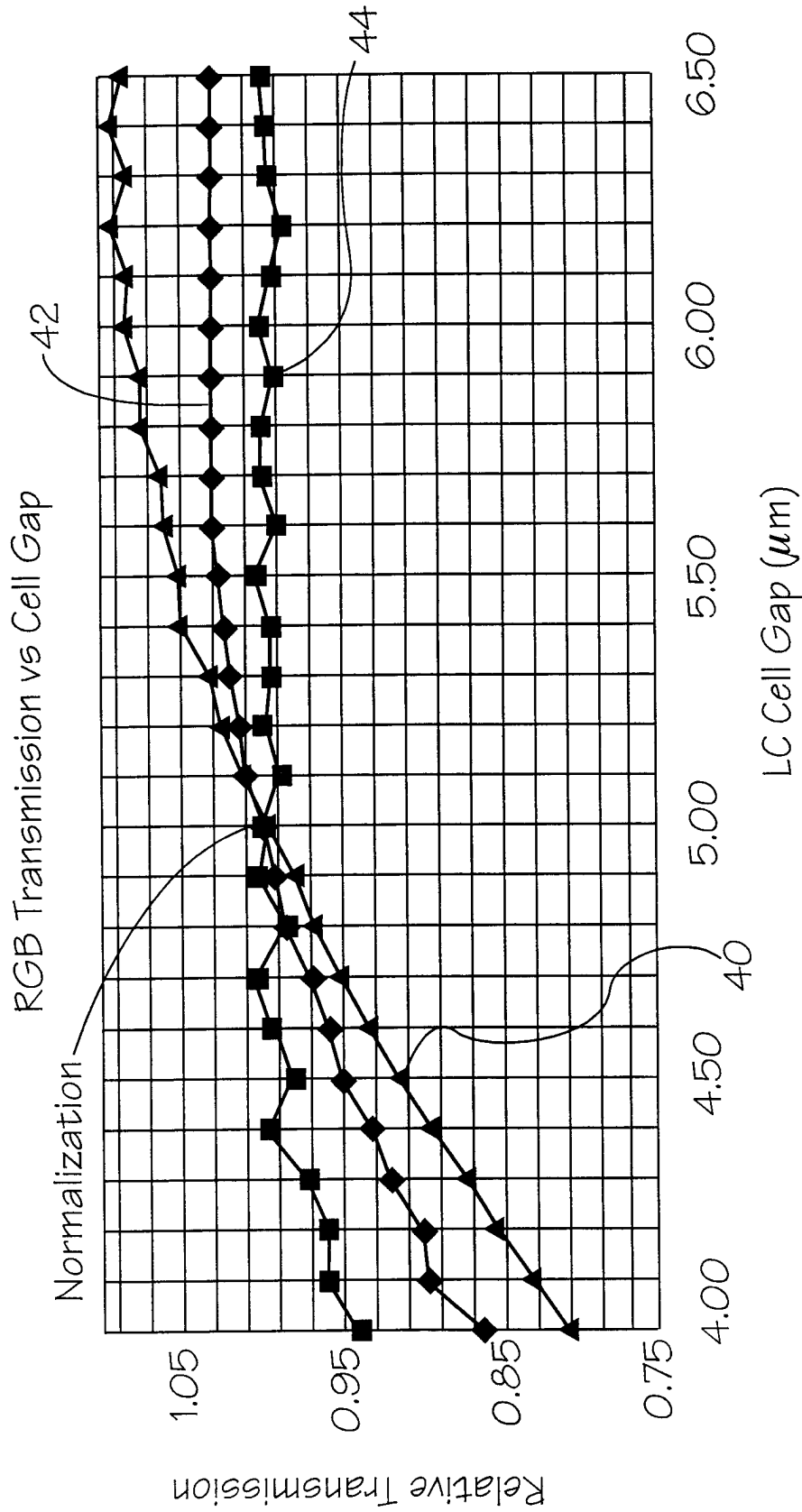

Figure 6

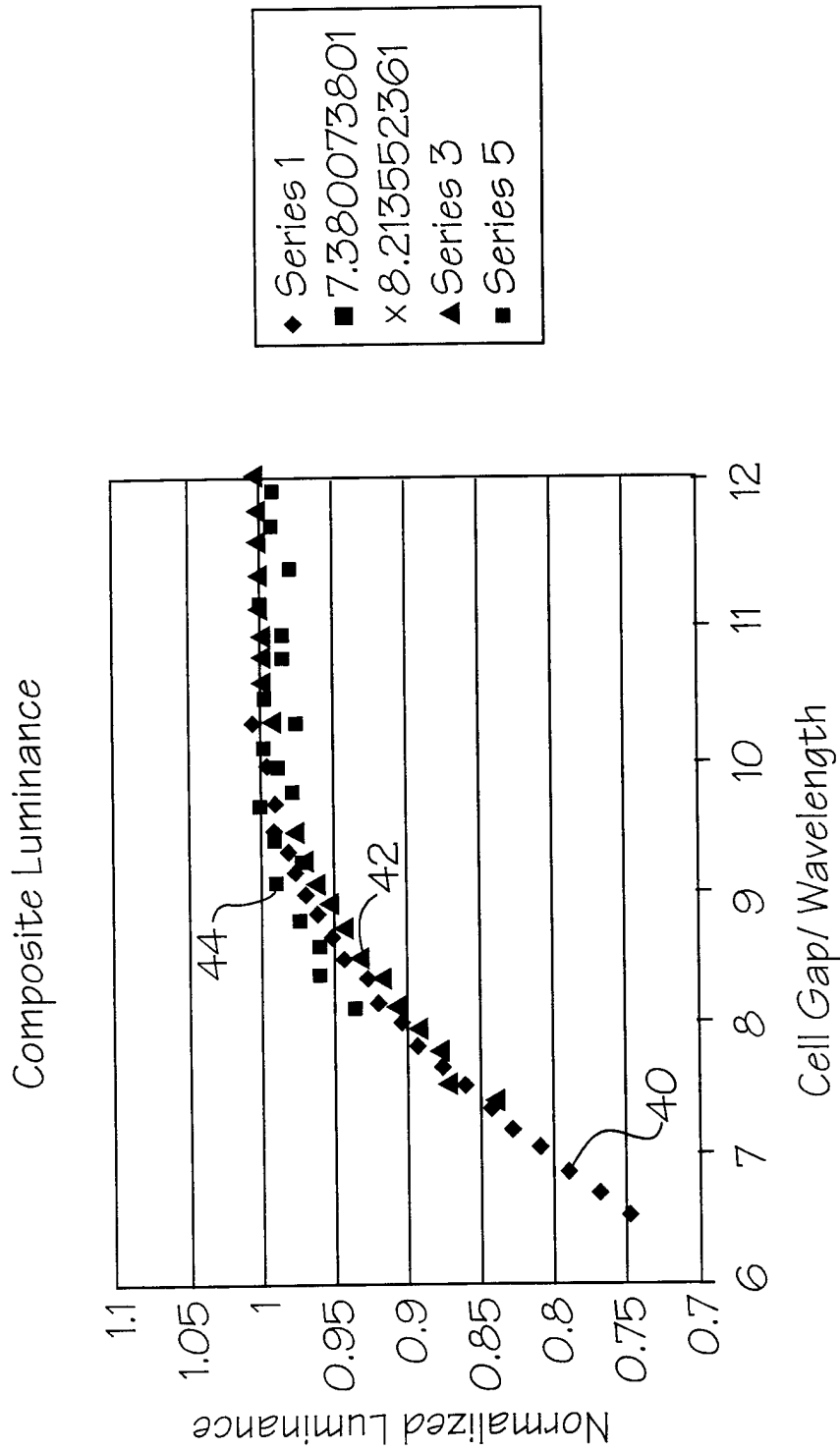

Figure 7

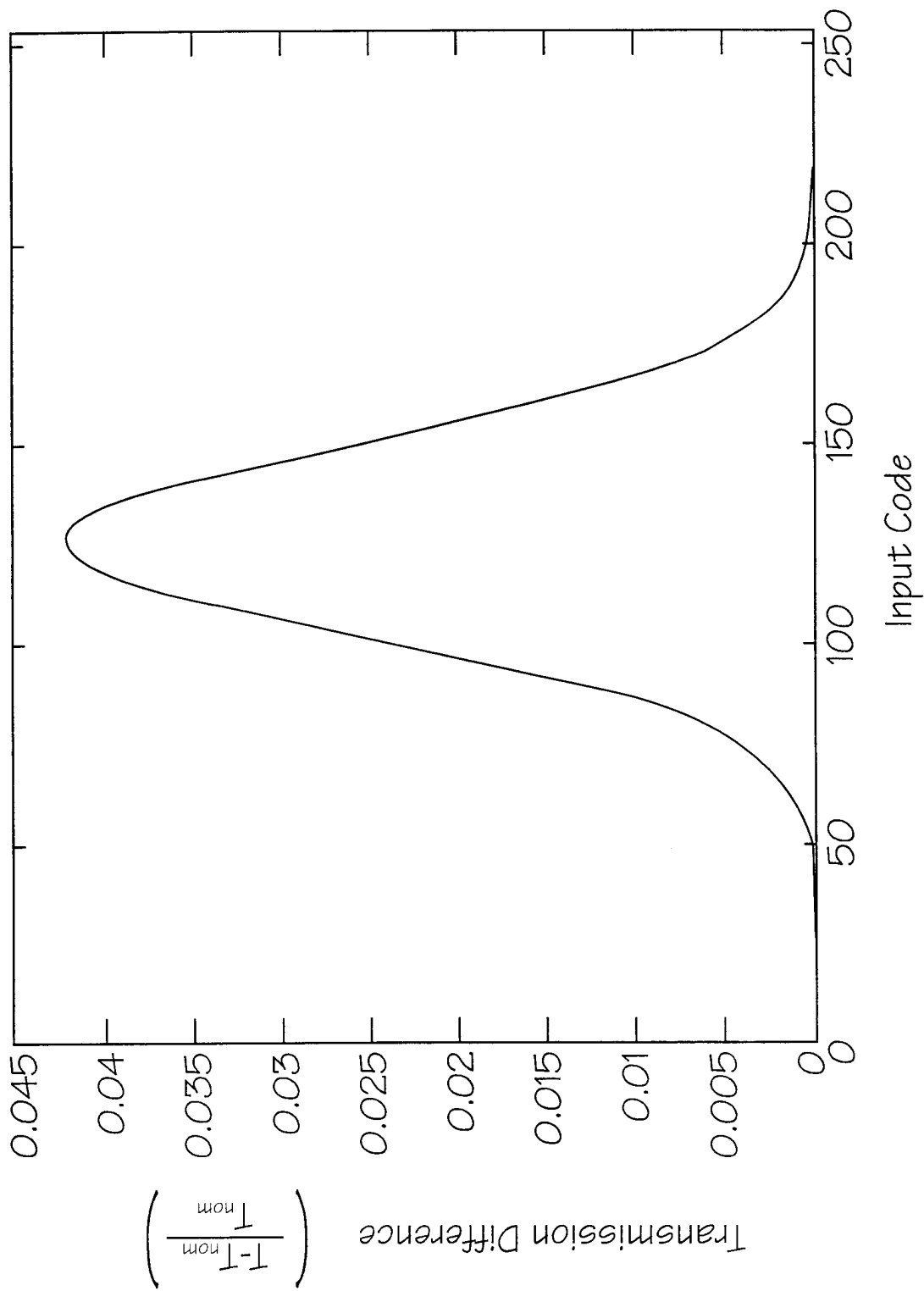

Figure 8

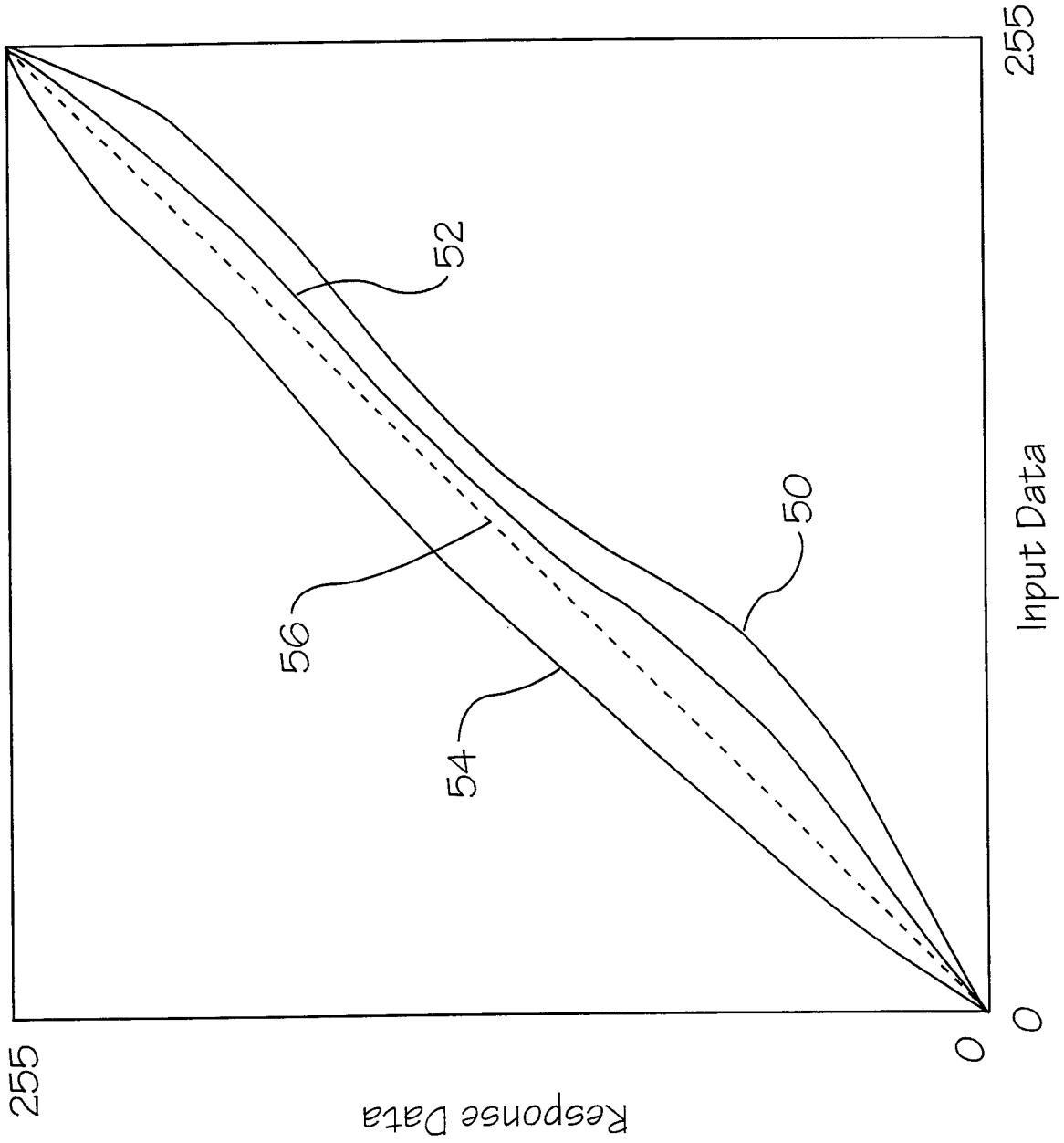
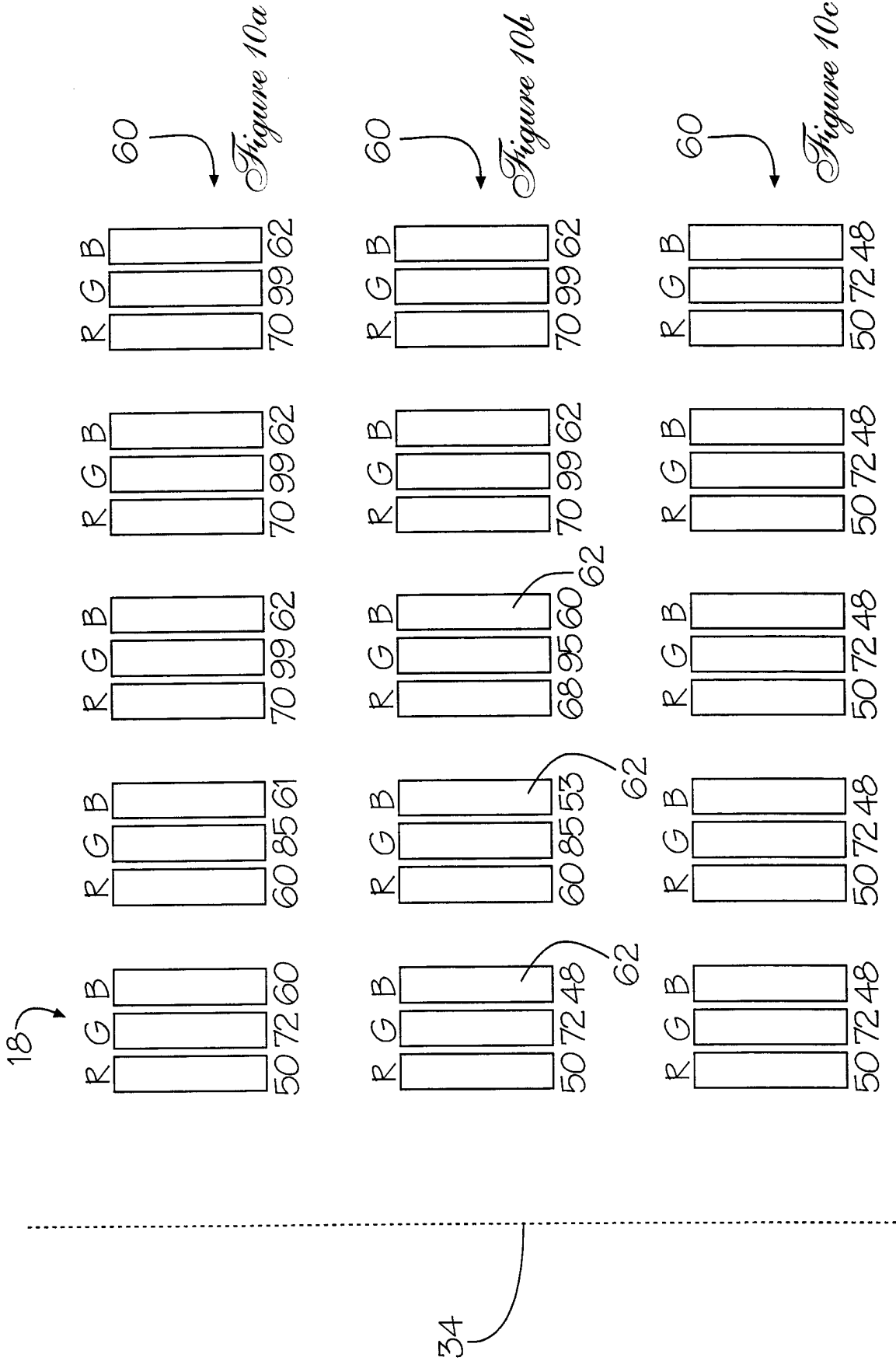

Figure 9



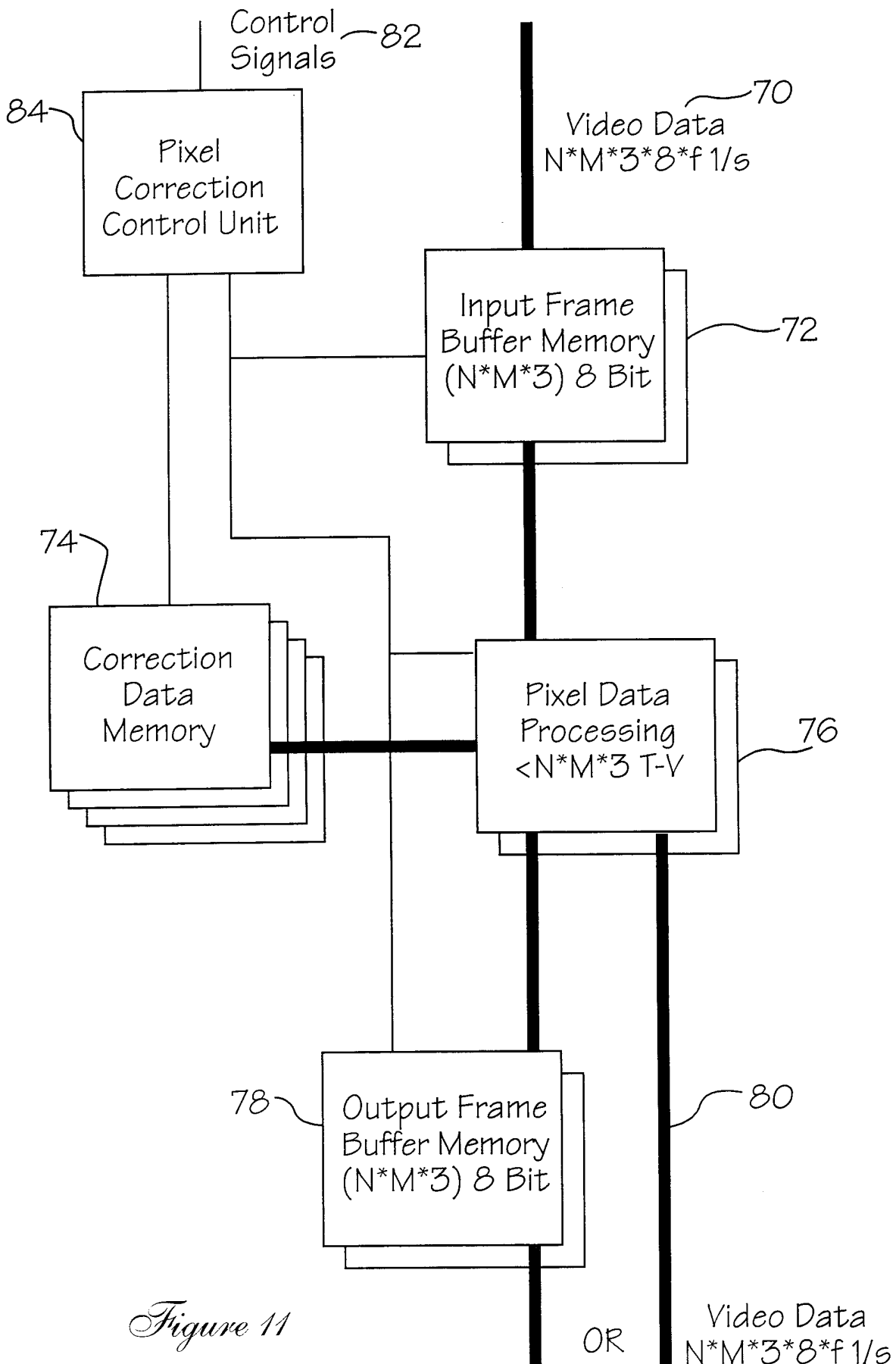

Figure 11

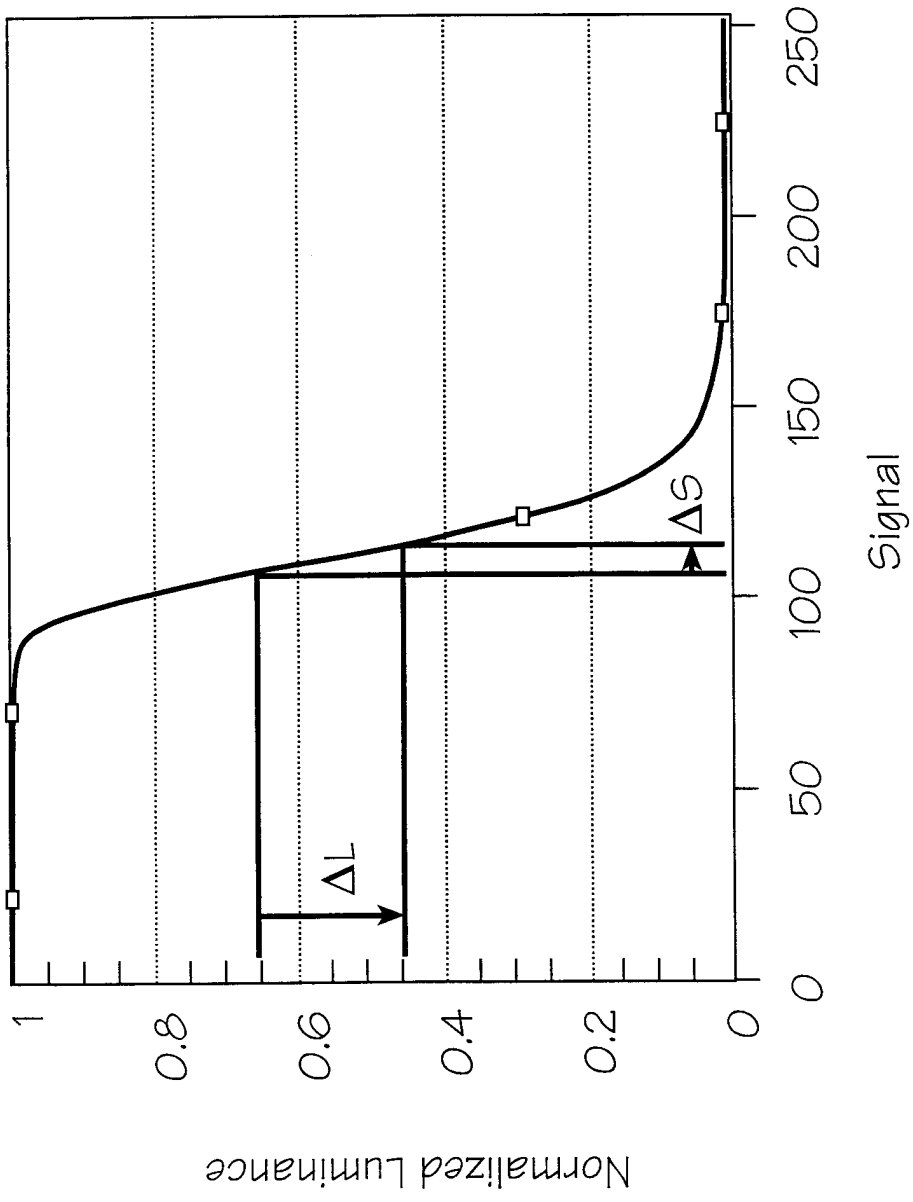

Figure 12

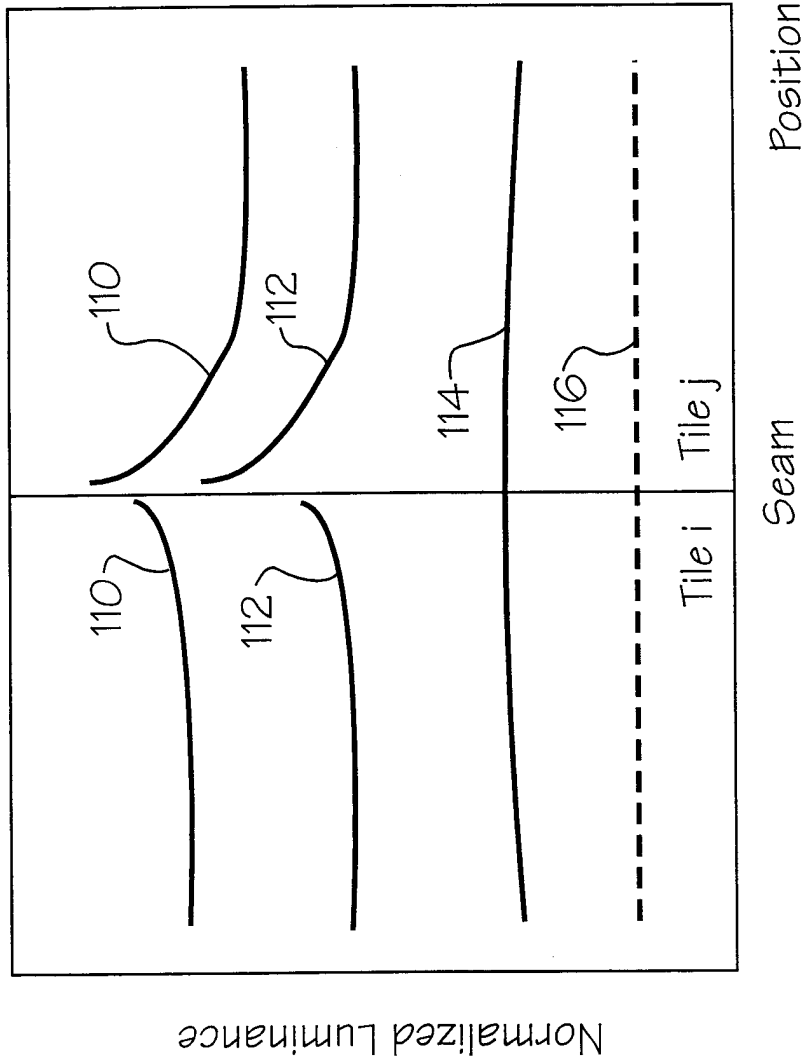

Figure 13

INTERNATIONAL SEARCH REPORT

International application No.
PCT/US00/05756**A. CLASSIFICATION OF SUBJECT MATTER**

IPC(7) : Please See Extra Sheet.

US CL : 349/73, 74, 153, 187, 190; 345/1, 88, 103, 199, 903; 348/383

According to International Patent Classification (IPC) or to both national classification and IPC

B. FIELDS SEARCHED

Minimum documentation searched (classification system followed by classification symbols)

U.S. : 349/73, 74, 153, 187, 190; 345/1, 88, 103, 199, 903; 348/383;

Documentation searched other than minimum documentation to the extent that such documents are included in the fields searched

Electronic data base consulted during the international search (name of data base and, where practicable, search terms used)

EAST, WEST, NPL

C. DOCUMENTS CONSIDERED TO BE RELEVANT

Category*	Citation of document, with indication, where appropriate, of the relevant passages	Relevant to claim No.
A, P	US 6,005,649 A (KRUSIUS et al) 21 December 1999, the entire document.	1-14
A	US 5,867,236 A (BABUKA et al) 02 February 1999, the entire document	1-14, 35, 43-45
A	US 5,661,531 A (GREENE et al) 26 August 1997, the entire document	1-14, 35, 43
A, P	US 6,020,868 A (GREENE et al) 01 February 2000, the entire document	1-45
A	US 4,990,905 A (KUIJK) 05 February 1991, the entire document.	35-42
A	US 5,847,785 A (IZUMI) 08 December 1998, the entire document.	1-14

 Further documents are listed in the continuation of Box C.
 See patent family annex.

* Special categories of cited documents:	"T"	later document published after the international filing date or priority date and not in conflict with the application but cited to understand the principle or theory underlying the invention
"A" document defining the general state of the art which is not considered to be of particular relevance	"X"	document of particular relevance; the claimed invention cannot be considered novel or cannot be considered to involve an inventive step when the document is taken alone
"E" earlier document published on or after the international filing date	"Y"	document of particular relevance; the claimed invention cannot be considered to involve an inventive step when the document is combined with one or more other such documents, such combination being obvious to a person skilled in the art
"L" document which may throw doubts on priority claim(s) or which is cited to establish the publication date of another citation or other special reason (as specified)	"&"	document member of the same patent family
"O" document referring to an oral disclosure, use, exhibition or other means		
"P" document published prior to the international filing date but later than the priority date claimed		

Date of the actual completion of the international search

09 MAY 2000

Date of mailing of the international search report

03 JAN 2001

Name and mailing address of the ISA/US
Commissioner of Patents and Trademarks
Box PCT
Washington, D.C. 20231

Facsimile No. (703) 305-3230

Authorized officer

TARIFUR R. CHOWDHURY

Telephone No. (703) 308-4115

INTERNATIONAL SEARCH REPORT

International application No.
PCT/US00/05756

C (Continuation). DOCUMENTS CONSIDERED TO BE RELEVANT		
Category*	Citation of document, with indication, where appropriate, of the relevant passages	Relevant to claim No.
A	US 5,796,452 A (PIERSON) 18 August 1998, the entire document.	1-14
A	US 5,805,117 A (MAZUREK et al) 08 September 1998, the entire document.	1-45
A	US 5,903,328 A (GREENE et al) 11 May 1999, the entire document.	1-14

INTERNATIONAL SEARCH REPORT

International application No.
PCT/US00/05756**Box I Observations where certain claims were found unsearchable (Continuation of item 1 of first sheet)**

This international report has not been established in respect of certain claims under Article 17(2)(a) for the following reasons:

1. Claims Nos.:
because they relate to subject matter not required to be searched by this Authority, namely:

2. Claims Nos.:
because they relate to parts of the international application that do not comply with the prescribed requirements to such an extent that no meaningful international search can be carried out, specifically:

3. Claims Nos.:
because they are dependent claims and are not drafted in accordance with the second and third sentences of Rule 6.4(a).

Box II Observations where unity of invention is lacking (Continuation of item 2 of first sheet)

This International Searching Authority found multiple inventions in this international application, as follows:

Please See Extra Sheet.

1. As all required additional search fees were timely paid by the applicant, this international search report covers all searchable claims.
2. As all searchable claims could be searched without effort justifying an additional fee, this Authority did not invite payment of any additional fee.
3. As only some of the required additional search fees were timely paid by the applicant, this international search report covers only those claims for which fees were paid, specifically claims Nos.:

4. No required additional search fees were timely paid by the applicant. Consequently, this international search report is restricted to the invention first mentioned in the claims; it is covered by claims Nos.:

Remark on Protest

- The additional search fees were accompanied by the applicant's protest.
 No protest accompanied the payment of additional search fees.

INTERNATIONAL SEARCH REPORT

International application No.
PCT/US00/05756

A. CLASSIFICATION OF SUBJECT MATTER:

IPC (7):

G02F 1/133, 1/1347, 1/13, 1/1339; G09G 5/00, 3/36, 5/06; H04N 5/66

BOX II. OBSERVATIONS WHERE UNITY OF INVENTION WAS LACKING

This ISA found multiple inventions as follows:

Group I, claim(s) 1-14, drawn to a tiled flat-panel liquid crystal display, classified in class 349, 074.

Group II, claim(s) 15-34, drawn to a method for correcting luminance and chromaticity variations, classified in class 345.

Group III, claim(s) 35-45, drawn to a method for producing a tiled, flat-panel liquid crystal display, classified in class 349, subclass 187.

The inventions listed as Groups I-III do not relate to a single inventive concept under PCT Rule 13.1 because, under PCT Rule 13.2, they lack the same or corresponding special technical features for the following reasons:

The means for selectively altering the pixel stimulation signals responsive to the edge effects of Group I does not include the specific details of the method for correcting luminance and chromaticity variations of Group II and the method for producing a tiled flat-panel display of Group III and could readily function without the specific steps.

The inventions of Groups II and III have different functions and operations. The differing would appear to make the inventions II and III patentable distinct from another i.e., a reference which anticipates or make obvious one of the II-III would not, by itself, make obvious any one of the remaining inventions.

Group II contains claims directed to more than one species of the generic invention. These species are deemed to lack Unity of Invention because they are not so linked as to form a single inventive concept under PCT Rule 13.1. In order for more than one species to be searched, the appropriate additional search fees must be paid. The species are as follows:

Species I: Claims 15-25;

Species II: Claims 26-34;

Group III contains claims directed to more than one species of the generic invention. These species are deemed to lack Unity of Invention because they are not so linked as to form a single inventive concept under PCT Rule 13.1. In order for more than one species to be searched, the appropriate additional search fees must be paid. The species are as follows:

Species I: Claims 35-42

Species II: Claims 43-45;

The species listed above do not relate to a single inventive concept under PCT Rule 13.1 because, under PCT Rule 13.2, the species lack the same or corresponding special technical features for the following reasons:

The invention of Group II, Species I, Claims 15-25, relates to a method for correcting luminance and chromaticity variations caused by tile edge, the steps comprising: arranging two LCD tiles; mapping the pixels in the tiles; determining a transfer function of the mapped region; and applying an inverse of the transfer function to the pixel stimulation signals whereas the invention of Group II, Species II, claims 26-34, relates to a method for correcting luminance and chromaticity variations caused by tile edge, the steps comprising: identifying an optical aberration affecting sub-pixels; determining a transfer function of the affected sub-pixels; and applying an inverse of the transfer function to the affected sub-pixels.

The invention of Group III, species I, Claims 35-42, relates to a method for producing a tiled flat-panel display, the steps comprising: arranging a plurality of individual display tiles; providing driver means for presenting sub-pixel stimulation signals; modifying the effective T-V curve of each of the sub-pixels; adjusting the luminance and chromaticity of sub-pixels disposed at interior regions of the individual display tiles; and adjusting the luminance and chromaticity of sub-pixels proximate the seams whereas the invention of Group III, species II, Claims 43-45, relates to a method for producing a tiled flat-panel display, the steps comprising: arranging a plurality of individual tiles; adjusting luminance and chromaticity of the sub-pixels located at interior regions; and blending the first and second predetermined levels.

专利名称(译)	补偿平铺平板液晶显示器的边缘效应和单元间隙变化		
公开(公告)号	EP1196813A1	公开(公告)日	2002-04-17
申请号	EP2000916093	申请日	2000-03-02
[标]申请(专利权)人(译)	彩虹展示公司		
申请(专利权)人(译)	彩虹显示器, INC.		
当前申请(专利权)人(译)	彩虹显示器, INC.		
[标]发明人	GREENE RAYMOND G KRUSIUS J PETER SKINNER DEAN W YOST BORIS		
发明人	GREENE, RAYMOND, G KRUSIUS, J., PETER SKINNER, DEAN, W. YOST, BORIS		
IPC分类号	G02F1/1347 G02F1/133 G02F1/1333 G06F3/147 G09G3/36 G09G5/393 G02F1/13 G02F1/1339 G09G5/00 G09G5/06 H04N5/66		
CPC分类号	G02F1/13336 G06F3/147 G09G3/3611 G09G5/393 G09G2300/026 G09G2310/0232 G09G2320/0233 Y10S345/903		
代理机构(译)	ROBERT, JEAN-PIERRE		
优先权	09/396142 1999-09-15 US		
外部链接	Espacenet		

摘要(译)

本发明的特征在于用于校正由于液晶单元间隙变化或在倾斜的平板显示器中出现的其他光学, 电光, 环境光, 电子, 机械和材料异常引起的变色和亮度变化的过程。这些修正的目的是实现视觉上无缝的外观。通过将输入视频数据 (70) 暂时存储在输入帧缓冲存储器 (72) 中, 从输入帧缓冲存储器 (72) 读取视频数据 (70) 来执行像素数据视频处理来实现绝对, 相对和/或平滑校正。) 和在像素校正控制单元 (84) 的控制下从校正数据存储单元 (74) 到像素数据处理器 (76) 的校正数据。此外, 像素校正控制单元 (84) 可以与像素数据处理单元 (76) 合并。在将校正后的像素数据发送到显示器之前, 也可以将其校正存储在输出帧缓冲存储器 (78) 中。描述了用于确定和应用这些校正的技术。