



(11) **EP 1 169 666 B1**

(12) **EUROPEAN PATENT SPECIFICATION**

(45) Date of publication and mention of the grant of the patent:
22.07.2009 Bulletin 2009/30

(21) Application number: **00904192.2**

(22) Date of filing: **04.01.2000**

(51) Int Cl.:
G02F 1/1335^(2006.01)

(86) International application number:
PCT/US2000/000059

(87) International publication number:
WO 2000/043832 (27.07.2000 Gazette 2000/30)

(54) **SUPER BRIGHT LOW REFLECTANCE LIQUID CRYSTAL DISPLAY**

EXTREM HELLE FLÜSSIGKRISTALLANZEIGE MIT GERINGER REFLEKTIVITÄT

AFFICHAGE A CRISTAUX LIQUIDES SUPER ECLATANT A FAIBLE REFLECTANCE

(84) Designated Contracting States:
DE FR GB IT

(30) Priority: **22.01.1999 US 235584**

(43) Date of publication of application:
09.01.2002 Bulletin 2002/02

(73) Proprietor: **White Electronic Designs Corp.**
Phoenix, AZ 85034 (US)

(72) Inventors:
• **SANELLE, Joseph, J.**
Westboro, MA 01581 (US)

• **BREILING, Diggy, R.**
Westboro, MA 01581 (US)

(74) Representative: **Schubert, Klemens**
Neue Promenade 5
10178 Berlin-Mitte (DE)

(56) References cited:

EP-A- 0 502 364	US-A- 3 869 196
US-A- 3 869 196	US-A- 4 715 686
US-A- 5 148 299	US-A- 5 179 457
US-A- 5 179 457	US-A- 5 430 607
US-A- 5 430 607	US-A- 5 523 873
US-A- 5 523 873	

EP 1 169 666 B1

Note: Within nine months of the publication of the mention of the grant of the European patent in the European Patent Bulletin, any person may give notice to the European Patent Office of opposition to that patent, in accordance with the Implementing Regulations. Notice of opposition shall not be deemed to have been filed until the opposition fee has been paid. (Art. 99(1) European Patent Convention).

Description

[0001] The present invention relates generally to liquid crystal displays and more particularly to an improved liquid crystal display exhibiting enhanced optical viewing performance.

[0002] Liquid crystal displays, which were first introduced in the 1970's and have since been used in watches, clocks, pocket calculators, portable personal computers, navigational instruments and the like, are electronically switched displays that make use of changes in the reflective properties of liquid crystals present in an electric field. A typical liquid crystal display comprises a liquid crystal display panel, said panel comprising a thin film of liquid crystals sandwiched between a pair of transparent electrodes. The ruggedized liquid crystal display panel is typically positioned between a pair of glass plates, the glass plates being sealed together around their respective edges. The glass plates may be assembled with spacers between them to maintain a constant separation distance. Two crossed axis polarizers are adhered to the respective inside surfaces of the glass plates, one polarizer also being adhered to the front of the liquid crystal display panel and the other polarizer also being adhered to the rear of the liquid crystal display panel. When a voltage is applied selectively across the electrodes, the liquid crystal molecules between them are rearranged or switched in polarization so that light is either reflected or absorbed in the region bounded by the electrodes to form characters or graphics. Many liquid crystal displays include a backlight for night or dark viewing, and many liquid crystal displays include a layer of indium tin oxide or another suitable material positioned between the front polarizer and the front glass plate for use as an electromagnetic interference shield. Some liquid crystal displays intended for use in cold environments also include a layer of indium tin oxide or another suitable material positioned between the rear polarizer and the rear glass plate and electrically connected to a power source for use as a heating element.

[0003] Some of the advantages of liquid crystal displays, as compared to other digital displays, are their comparatively low voltage and power requirements. Unfortunately, however, one of the principal disadvantages of liquid crystal displays is that, due to their low contrast and a "washed-out" effect caused by back-reflected ambient light seen by a viewer, they cannot easily be read under high ambient light conditions, such as when placed in direct sunlight.

[0004] One approach which has been taken to improve the viewing performance of liquid crystal displays, particularly when viewed under high ambient light conditions, has been to apply an anti-reflection coating to the front of the display. Although such an approach has provided some improvement to the viewing characteristics of liquid crystal displays by reducing the amount of back-reflected light seen by the viewer, further improvement is greatly needed.

[0005] A few patents in the field of liquid crystal display technology are described below.

[0006] In U.S. Patent No. 5,570,214, inventors Abileah et al., which issued October 29, 1996, there is disclosed a liquid crystal display comprising a plurality of pixels, each of the pixels being comprised of a pair of driving electrodes and a twisted nematic liquid crystal material located therebetween. The liquid crystal material is of a thickness "d" and has an anisotropy ΔN such that the product of $d \cdot \Delta N$ is about 400-550 nm, and the liquid crystal material is capable of twisting at least one normally incident visible wavelength of light passing therethrough in an amount of about 80°-100°. The device also comprises a rear, light-entrance polarizer having a transmission axis oriented in a first direction, a front, light-exit polarizer having a transmission axis oriented in a second direction with respect to the first direction thereby to define a normally white display, a rear retardation film disposed between the rear polarizer and the twisted nematic liquid crystal material, and a front retardation film disposed between the front polarizer and the liquid crystal material. The transmission axes of the retardation films are so arranged each with respect to the others so as to achieve a white light contrast ratio of at least about 10:1 over a horizontal angular span of at least about 100° and over a vertical angular span of greater than about 55°.

[0007] In U.S. Patent No. 5,594,568, inventors Abileah et al., which issued January 14, 1997, there is disclosed a normally white liquid crystal display comprising a rear, light-entrance polarizer having a transmission axis oriented in a first direction; a front, light-exit polarizer having a transmission axis oriented in a second direction with respect to the first direction so as to define a normally white display; a twisted nematic liquid crystal layer; and first and second positively birefringent uniaxial retardation films both disposed between the twisted nematic liquid crystal layer and one of the rear, light-entrance polarizer and the front, light-exit polarizer. The liquid crystal layer in the off state twists at least one normally incident visible wavelength of light less than about 110° as it passes therethrough, and the first and second uniaxial retardation films have retardation values of from about 80-200 nm. The transmission axes of the polarizers and optical axes of the retardation films are so arranged each with respect to the others so as to achieve high contrast ratios over a large range of predetermined viewing angles.

[0008] In U.S. Patent No. 5,706,068, inventors Abileah et al., which issued January 6, 1998, there is disclosed a liquid crystal display comprising a plurality of pixels, each of the pixels being comprised of a pair of driving electrodes and a twisted nematic liquid crystal material located therebetween. The liquid crystal material is of a thickness "d" and has an anisotropy ΔN such that the product of $d \cdot \Delta N$ is about 400-550 nm, and the liquid crystal material is capable of twisting at least one normally incident visible wavelength of light passing therethrough in an amount of about 80°-100°. The device also comprises a rear, light-entrance polarizer having a transmis-

sion axis oriented in a first direction, a front, light-exit polarizer having a transmission axis oriented in a second direction with respect to the first direction thereby to define a normally white display, a rear retardation film disposed between the rear polarizer and the twisted nematic liquid crystal material, and a front retardation film disposed between the front polarizer and the liquid crystal material. The transmission axes of the retardation films are so arranged each with respect to the others so as to achieve a white light contrast ratio of at least about 10:1 over a horizontal angular span of at least about 100° and over a vertical angular span of greater than about 55°.

[0009] In U.S. Patent No. 5,739,881, inventors Xu et al., which issued April 14, 1998, there is disclosed a normally white twisted nematic liquid crystal display comprising a liquid crystal layer for twisting at least one normally incident visible wavelength of light from about 80° to 100° as it passes therethrough when the liquid crystal layer is in substantially the off-state thereby defining a twisted nematic display. The display also comprises a pair of negative retarders sandwiching the liquid crystal layer therebetween and a pair of positive retarders sandwiching both the liquid crystal layer and the negative retarders therebetween, wherein the retardation value of each of the negative retarders is from about -60 to -200 nm and the retardation value of each of the positive retarders is from about 80 to 200 nm.

[0010] In U.S. Patent No. 5,523,873, inventors Bradford et al., describes an LCD heater including a substantially transparent indium-tin-oxide (ITO) heating layer deposited on a transparent glass rear cover sheet.

[0011] In U.S. Patent No. 5,148,299, inventor Terada, describes a liquid crystal display device having connecting means for connecting the transparent electrode of the compensating cell to ground potential for preventing exterior static electricity.

[0012] The European Patent Application No. 0 502 364, inventor Collister, discloses a liquid crystal display that minimizes disabling due to static electricity.

[0013] In U.S. Patent No. 3,869,196, inventor Kubota, discloses a liquid crystal display device, said liquid crystal display using liquid crystal material to rotate the plane of polarized light by 90° both the thickness and the loss of light by reflection are decreased by using one surface from each of a polarizer and an analyzer for forming a cell in which the liquid crystal material is confined.

[0014] In U.S. Patent No. 5,430,60.7, inventor Smith, discloses a portable computer including a processor, processor associated memory and control circuitry, and a memory disk drive assembly for storing software programs to form an integral computer unit. The integral computer unit has a display module.

[0015] In U. S. Patent No. 5,179,457, inventors Hirata et al. there is disclosed a liquid crystal display device, said device includes a phase-plate disposed between a pair of substrates, preferably inside of the electrode, to increase the transmission rate and improve the contrast ratio of the display.

SUMMARY OF THE INVENTION

[0016] It is an object of the present invention to provide a novel liquid crystal display.

5 **[0017]** It is another object of the present invention to provide a liquid crystal display that ameliorates at least some of the problems discussed above in connection with existing liquid crystal displays.

10 **[0018]** It is yet another object of the present invention to provide a liquid crystal display as described above that includes a novel optical filtering arrangement.

15 **[0019]** The present invention is based, in part, on the innovative discovery that the amount of back-reflected light seen by a viewer of a liquid crystal display can be substantially reduced and, therefore, that the viewing characteristics of a liquid crystal display can be substantially improved by moving the front polarizer from its conventional location where it is adhered to the front surface of the liquid crystal display panel and is positioned rearwardly relative to a first glass plate to a new location where it is in front of said first glass plate and is adhered to the back surface of another glass plate itself positioned in front of said first glass plate.

20 **[0020]** Therefore, according to one aspect of the invention, there is provided a liquid crystal display comprising (a) a first glass plate; (b) a second glass plate; (c) a liquid crystal display panel positioned between said first and second glass plates; (d) a rear polarizer positioned between said liquid crystal display panel and said second glass plate; and (e) a front polarizer positioned in front of said first glass plate, said front polarizer being crossed relative to said rear polarizer.

25 **[0021]** In a preferred embodiment, the liquid crystal display comprises a first glass substrate, a second glass substrate and an active matrix liquid crystal display panel. The display additionally comprises a rear polarizer, the front surface of said rear polarizer being adhered to the rear surface of the active matrix liquid crystal display panel with an index-matched, pressure sensitive adhesive.
30 The display further comprises an indium tin oxide thin film coating adapted to be used as a heating element, said coating being applied to the front surface of the second glass substrate. The front surface of said heating element is adhered to the rear surface of the rear polarizer with a silicone-based, index-matched, optical bonding material.

35 **[0022]** In addition, said ruggedized liquid crystal display may comprise an indium tin oxide thin film coating usable as an electromagnetic interference (EMI) shield, said coating being applied to the rear surface of the first glass substrate. The rear surface of said EMI-coated glass substrate is adhered to the front surface of the active matrix liquid crystal display panel with the above-mentioned silicone-based, index-matched, optical bonding material.
40

45 **[0023]** The display also comprises a front polarizer, said front polarizer having a crossed axis relative to said rear polarizer. The rear surface of the front polarizer is

adhered to the front surface of the first glass substrate by the above-mentioned silicone-based, index-matched, optical bonding material. The display additionally comprises a third glass substrate, the rear surface of the third glass substrate being bonded to the front of the front polarizer by the above-mentioned index-matched, pressure sensitive adhesive. The display further includes an anti-reflection (AR) thin film coating applied to the front surface of the third glass substrate.

[0024] In order to minimize the reflection of ambient light by the display into the view of an observer, the various elements of the display preferably have respective indices of refraction that differ as minimally as possible. Nevertheless, as can readily be appreciated, this index-matching approach cannot completely eliminate the reflection of ambient light off the various elements of the display. In fact, some elements, such as the indium tin oxide electromagnetic interference shield, are quite reflective. The placement of the front polarizer in front of the indium tin oxide electromagnetic interference shield in accordance with the teachings of the present invention, instead of behind it, substantially ameliorates the problem of reflection off said electromagnetic interference shield. This is because ambient light passing through said front polarizer becomes polarized in a first direction. If said polarized ambient light is then reflected off said electromagnetic interference shield, its polarization state changes in such a way that it cannot pass back through said front polarizer into the view of the viewer.

[0025] The terms "front," "in front of," "front surface" or the like, when used herein to describe an element of a liquid crystal display or to denote the relative positions of two or more elements of a liquid crystal display, refer directionally to the viewer side of the liquid crystal display. The terms "behind," "in back of," "rear surface" or the like, when used herein to describe an element of a liquid crystal display or to denote the relative positions of two or more elements of a liquid crystal display, refer directionally to the side of the liquid crystal display facing away from the viewer, typically the backlight side of the display.

[0026] Additional objects, features, aspects and advantages of the present invention will be set forth, in part, in the description which follows and, in part, will be obvious from the description or may be learned by practice of the invention. Certain embodiments of the invention will be described hereafter in sufficient detail to enable those skilled in the art to practice the invention, and it is to be understood that other embodiments may be utilized and that structural or other changes may be made without departing from the scope of the invention. The following detailed description is, therefore, not to be taken in a limiting sense, and the scope of the present invention is best defined by the appended claims.

BRIEF DESCRIPTION OF THE DRAWINGS

[0027] The accompanying drawing, which is hereby incorporated into and constitutes a part of this specification,

illustrates a preferred embodiment of the invention and, together with the description, serves to explain the principles of the invention. In the drawing wherein like reference numerals represent like parts:

Fig. 1 is a schematic section view of one embodiment of a liquid crystal display constructed according to the teachings of the present invention.

DETAILED DESCRIPTION OF PREFERRED EMBODIMENTS

[0028] As noted above, the present invention is directed to the problem of poor viewing performance or "wash-out" in liquid crystal displays, said problem occurring most notably under high ambient light conditions. More specifically, the problem is caused by the reflection of ambient light by the liquid crystal display back towards the viewer, thereby obscuring the image generated by the liquid crystal display. Moreover, in those instances in which the liquid crystal display includes an electromagnetic interference shield, often in the form of an indium tin oxide coating applied to the rear surface of the front glass panel of the display, the problem of ambient light reflection into the view of an observer is made more acute.

[0029] As will hereinafter be described, the present inventors have addressed the foregoing problem by, among other things, re-positioning the front polarizer of the liquid crystal display so that it is placed in front of the electromagnetic interference shield, instead of behind it. In this manner, as ambient light passes through the front polarizer, said ambient light becomes polarized in a first direction. If said polarized ambient light is then reflected off said electromagnetic interference shield, its state of polarization changes. With its polarization state thus changed, the reflected ambient light cannot pass back through the front polarizer into the view of the observer.

[0030] Referring now to Fig. 1, there is shown a schematic section view of one embodiment of a liquid crystal display constructed according to the teachings of the present invention, said liquid crystal display being represented generally by reference numeral 11.

[0031] Liquid crystal display 11 comprises a first glass substrate 13, a second glass substrate 15 and a liquid crystal display (LCD) panel 17, LCD panel 17 being positioned between glass substrates 13 and 15. Glass substrates 13 and 15, which may be conventional in nature, typically have a thickness of about 0.04 inch and may be made of a borosilicate, a sodalime or the like. Preferably, glass substrates 13 and 15 have indices of refraction that substantially match that of LCD panel 17. LCD panel 17, which is preferably (but not necessarily) an active matrix liquid crystal display (AMLCD) panel, may be conventional in nature and includes liquid crystals (not shown) sandwiched between a pair of transparent electrodes (not shown).

[0032] Display 11 also comprises a rear polarizer 19,

rear polarizer 19 preferably having an index of refraction that substantially matches that of LCD panel 17. The front surface of rear polarizer 19 is preferably adhered to the rear surface of LCD panel 17 with a layer 21 of a conventional index-matched, pressure sensitive adhesive (layer 21 being about .001 inch in thickness). (Where rear polarizer 19 is a conventional non-compensated linear polarizer, layer 21 may be applied to polarizer 19 by the polarizer's manufacturer.) Rear polarizer 19 may be, for example, a conventional linear polarizer with an expanded viewing angle compensation film (for use in countering the birefringent effect of the liquid crystal material in panel 17) or a conventional non-compensated linear polarizer. Where rear polarizer 19 is a linear polarizer with an expanded viewing angle compensation film, the compensation film faces forwardly towards panel 17.

[0033] In addition, display 11 preferably comprises a thin film coating 23 applied to the front surface of second glass substrate 15. Coating 23, whose index of refraction substantially matches that of glass substrate 15, is preferably made of indium tin oxide or another suitable material so that, when coupled to a power source, coating 23 serves as a heating element to heat display 11 when it is used in cold ambient temperature conditions. The front surface of coating 23 is preferably adhered to the rear surface of rear polarizer 19 with a layer 25 of an index-matched, optical bonding material. Layer 25, which may be made of, for example, a silicone-based or epoxy-based, index-matched, optical bonding material, advantageously eliminates any air gap between rear polarizer 19 and coating 23.

[0034] Display 11 preferably further comprises an electromagnetic interference (EMI) shield 27. EMI shield 27, which is preferably in the form of an indium tin oxide thin film coating applied to the rear surface of first glass substrate 13, shields LCD panel 17 from incoming electromagnetic radiation by absorbing said radiation. EMI shield 27 preferably has an index of refraction that substantially matches that of LCD panel 17, and the rear surface of EMI shield 27 is preferably adhered to the front surface of LCD panel 17 with a layer 29 of the above-mentioned index-matched, optical bonding material.

[0035] Display 11 also comprises a front polarizer 31, front polarizer 31 being similar to rear polarizer 19 but crossed relative thereto. Where front polarizer 31 (like rear polarizer 19) includes a compensation film, the compensation film of front polarizer 31 faces forwardly away from LCD panel 17. Front polarizer 31 preferably has an index of refraction substantially matching that of first glass substrate 13, and the rear surface of front polarizer 31 is preferably adhered to the front surface of first glass substrate 13 by a layer 33 of the above-mentioned index-matched, optical bonding material.

[0036] Display 11 additionally comprises a third glass substrate 35, which may be identical in composition to glass substrates 13 and 15. Third glass substrate 35 preferably has index of refraction substantially matching that of front polarizer 31, and the rear surface of third glass

substrate 35 is preferably bonded to the front of front polarizer 31 by a layer 37 of the above-mentioned index-matched, pressure sensitive adhesive. The peripheries of first glass substrate 13, second glass substrate 15 and third glass substrate 35 are preferably externally sealed to contain those elements of display 11 sandwiched therebetween.

[0037] Display 11 further includes a conventional anti-reflection thin film coating 39 applied to the front surface of third glass substrate 35. Coating 39, which is typically about 1-2 microns thick, may be made of, for example, magnesium fluoride and/or quartz.

[0038] Display 11 further includes a backlight 41, which may be conventional in nature, positioned behind second glass substrate 15.

[0039] Display 11 may be used in the conventional manner; however, because of its construction, display 11 exhibits improved optical viewing performance.

[0040] The embodiments of the present invention recited herein are intended to be merely exemplary and those skilled in the art will be able to make numerous variations and modifications to it without departing from the spirit of the present invention. All such variations and modifications are intended to be within the scope of the present invention as defined by the claims appended hereto.

Claims

1. A liquid crystal display (11) comprising:

a first glass substrate (13); a second glass substrate (15); a liquid crystal display panel (17) positioned between said first glass substrate (13) and said second glass substrate (15); a rear polarizer (19) positioned between said liquid crystal display panel (17) and said second glass substrate (15); and a front polarizer (31), said front polarizer (31) being crossed relative to said rear polarizer (19) **characterized in that** said rear polarizer (19) is adhered directly to said liquid crystal display panel (17) with an adhesive (21) and **in that** said front polarizer (31) is positioned in front of said first glass substrate (13).

2. The liquid crystal display (11) as claimed in claim 1 further comprising an electromagnetic interference shield (27) positioned between said first glass substrate (13) and said liquid crystal display panel (17).

3. The liquid crystal display (11) as claimed in claim 2 wherein said electromagnetic interference shield (27) is an indium tin oxide thin film coating applied to the first glass substrate (13).

4. The liquid crystal display (11) as claimed in claim 1 further comprising a third glass substrate (35); said

- third glass substrate (35) being positioned in front of said front polarizer (31).
5. The liquid crystal display (11) as claimed in claim 4 further comprising an antireflection coating (39), said anti-reflection coating (39) being applied to the front of said third glass substrate (35). 5
 6. The liquid crystal display (11) as claimed in claim 1 wherein each of said front polarizer (31) and said rear polarizer (19) is a non-compensated linear polarizer. 10
 7. The liquid crystal display (11) as claimed in claim 1 wherein each of said front polarizer (31) and said rear polarizer (19) includes a compensation layer. 15
 8. The liquid crystal display (11) as claimed in claim 7 wherein said compensation layer of each of said front polarizer (31) and said rear polarizer (19) faces away from said liquid crystal display panel (17). 20
 9. The liquid crystal display (11) as claimed in claim 1. wherein said liquid crystal display panel (17) is an active matrix liquid crystal display panel. 25
 10. The liquid crystal display (11) as claimed in claim 1 further comprising a backlight (41), said backlight (41) being positioned behind said second glass substrate (15). 30
 11. The liquid crystal display (11) as claimed in claim 1 further comprising a heating element (23) adapted to be connected to a power source, said heating element (23) being positioned between said rear polarizer (19) and said second glass substrate (15). 35
 12. The liquid crystal display (11) as claimed in claim 11 wherein said heating element (23) comprises an indium tin oxide coating applied to said second glass substrate (15). 40
 13. The liquid crystal display (11) as claimed in claim 2 further comprising: 45
 - a third glass substrate (35) positioned in front of said front polarizer (31).
 14. The liquid crystal display (11) as claimed in claim 13 wherein all of said first glass substrate (13), said second glass substrate (15), said third glass substrate (35), said liquid crystal display panel (17), said front polarizer (31), said rear polarizer (19) and said electromagnetic interference shield (27) have indices of refraction that are substantially matched. 50
 15. The liquid crystal display (11) as claimed in claim 14 further comprising a heating element (23) positioned between said rear polarizer (19) and said second glass substrate (15) and adapted to be connected to a power source for use as a heating element, said heating element (23) having an index of refraction substantially matching that of said rear polarizer (19) and that of said second glass substrate (15).
 16. The liquid crystal display (11) as claimed in claim 15 wherein said heating element (23) is a coating applied to said third glass substrate (35) and wherein said electromagnetic shield (27) is a coating applied to said first glass substrate (13).
 17. The liquid crystal display (11) as claimed in claim 16 wherein said front polarizer (31) is adhered to said third glass substrate (35) with an index-matched pressure sensitive adhesive (37) and is bonded to said first glass substrate (13) with an index-matched optical bonding material (33), wherein said rear polarizer (19) is adhered to said liquid crystal panel (17) with an index-matched pressure sensitive adhesive (21) and is bonded to said heating element (23) with an index-matched optical bonding material (25) and wherein said electromagnetic interference shield (27) is bonded to said liquid crystal display panel (17) with an index-matched optical bonding material (29).
 18. The liquid crystal display (11) as claimed in claim 17 further comprising an antireflection coating (39) applied to the front of said third glass substrate (35).
 19. The liquid crystal display (11) as claimed in claim 18 further comprising a backlight (41) positioned behind said second glass substrate (15).
 20. The liquid crystal display (11) as claimed in claim 19 wherein said liquid crystal display panel (17) is an active matrix liquid crystal display panel.
 21. The liquid crystal display (11) as claimed in claim 19 wherein said front polarizer (31) and said rear polarizer (19) are non-compensated linear polarizers.
 22. The liquid crystal display (11) as claimed in claim 19 wherein each of said front polarizer (31) and said rear polarizer (19) includes a compensation layer, said compensation layer facing said liquid crystal display panel (17).

Patentansprüche

1. Flüssigkristallanzeige (11), umfassend:

ein erstes Glassubstrat (13); ein zweites Glassubstrat (15); ein Flüssigkristallanzeigepanel (17), das zwischen dem genannten ersten Glassubstrat (13) und dem genannten zweiten Glas-

- substrat (15) positioniert ist; einen Rückpolarisator (19), der zwischen dem genannten Flüssigkristallanzeigepanel (17) und dem genannten zweiten Glassubstrat (15) positioniert ist; und einen Frontpolarisator (31), wobei der genannte Frontpolarisator (31) quer in Bezug auf den genannten Rückpolarisator (19) steht, **dadurch gekennzeichnet, dass** der genannte Rückpolarisator (19) direkt an das genannte Flüssigkristallanzeigepanel (17) mit einem Klebstoff (21) geklebt ist, und **dadurch**, dass der genannte Frontpolarisator (31) vor dem genannten ersten Glassubstrat(13) positioniert ist.
2. Flüssigkristallanzeige (11), gemäß Anspruch 1, die weiterhin eine Abschirmung gegen elektromagnetische Störungen (27) umfasst, welche zwischen dem genannten ersten Glassubstrat (13) und dem genannten Flüssigkristallanzeigepanel (17) positioniert ist.
 3. Flüssigkristallanzeige (11), gemäß Anspruch 2, worin die genannte Abschirmung gegen elektromagnetische Störungen (27) ein Indiumzinnoxid-Dünnschichtfilm ist, welcher auf das erste Glassubstrat (13) aufgebracht ist.
 4. Flüssigkristallanzeige (11), gemäß Anspruch 1, weiterhin ein drittes Glassubstrat (35) umfassend, wobei das genannte dritte Glassubstrat (35) vor dem genannten Frontpolarisator (31) positioniert ist.
 5. Flüssigkristallanzeige (11), gemäß Anspruch 4, weiterhin eine Antireflexionsbeschichtung (39) umfassend, wobei die genannte Antireflexionsbeschichtung (39) auf der Vorderseite des genannten dritten Glassubstrats (35) aufgebracht ist.
 6. Flüssigkristallanzeige (11), gemäß Anspruch 1, worin sowohl der genannte Frontpolarisator (31) als auch der genannte Rückpolarisator (19) ein nicht-kompensierender Linearpolarisator ist.
 7. Flüssigkristallanzeige (11), gemäß Anspruch 1, worin sowohl der genannte Frontpolarisator (31) als auch der genannte Rückpolarisator (19) eine Kompensationsschicht einschließen.
 8. Flüssigkristallanzeige (11), gemäß Anspruch 7, worin die genannte Kompensationsschicht sowohl des genannten Frontpolarisators (31) als auch des genannten Rückpolarisators (19) von dem genannten Flüssigkristallanzeigepanel (17) wegzeigen.
 9. Flüssigkristallanzeige (11), gemäß Anspruch 1, worin das genannte Flüssigkristallanzeigepanel (17) ein Aktiv-Matrix-Flüssigkristallanzeigepanel ist.
 10. Flüssigkristallanzeige (11), gemäß Anspruch 1, weiterhin eine Hintergrundbeleuchtung (41) umfassend, wobei die genannte Hintergrundbeleuchtung (41) hinter dem genannten zweiten Glassubstrat (15) positioniert ist.
 11. Flüssigkristallanzeige (11), gemäß Anspruch 1, weiterhin ein Heizelement (23) umfassend, das angepasst ist, um mit einer Stromquelle verbunden zu werden, wobei das genannte Heizelement (23) zwischen dem genannten Rückpolarisator (19) und dem genannten zweiten Glassubstrat (15) positioniert ist.
 12. Flüssigkristallanzeige (11), gemäß Anspruch 11, worin das genannte Heizelement (23) eine Indiumzinnoxid-Beschichtung umfasst, die auf dem genannten zweiten Glassubstrat (15) aufgebracht ist.
 13. Flüssigkristallanzeige (11), gemäß Anspruch 2, weiterhin umfassend:
 - ein drittes Glassubstrat (35), das vor dem genannten Frontpolarisator (31) positioniert ist.
 14. Flüssigkristallanzeige (11), gemäß Anspruch 13, worin das genannte erste Glassubstrat (13), das genannte zweite Glassubstrat (15), das genannte dritte Glassubstrate (35), das genannte Flüssigkristallanzeigepanel (17), der genannte Frontpolarisator (31), der genannte Rückpolarisator (19) und Abschirmung gegen elektromagnetische Störungen (27) Brechungsindizes haben, die im Wesentlichen einander entsprechen.
 15. Flüssigkristallanzeige (11), gemäß Anspruch 14, weiterhin ein Heizelement (23) umfassend, das zwischen dem genannten Rückpolarisator (19) und dem genannten zweiten Glassubstrat (15) positioniert ist und angepasst ist, um mit einer Stromquelle für die Verwendung als Heizelement verbunden zu werden, wobei das genannte Heizelement (23) einen Brechungsindex besitzt, welcher dem des genannten Rückpolarisators (19) und des genannten zweiten Glassubstrats (15) entspricht.
 16. Flüssigkristallanzeige (11), gemäß Anspruch 15, worin das genannte Heizelement (23) eine Beschichtung ist, die auf das genannte dritte Glassubstrat (35) aufgebracht ist, und worin die genannte elektromagnetische Abschirmung (27) eine Beschichtung ist, die auf dem ersten Glassubstrat (13) aufgebracht ist.
 17. Flüssigkristallanzeige (11), gemäß Anspruch 16, worin der genannte Frontpolarisator (31) auf das genannte dritte Glassubstrat (35) mit einem Index-anpassenden Haftkleber (37) geklebt ist und an das genannte erste Glassubstrat (13) mittels eines Index-

- angepassten optischen Bindungsmaterials (33) gebunden ist, worin der genannte Rückpolarisator (19) an das genannte Flüssigkristallanzeigepanel (17) mit einem Index-angepassten Haftkleber (21) geklebt ist und an das genannte Heizelement (23) mittels eines Index-angepassten optischen Bindungsmaterials (25) gebunden ist, und worin die Abschirmung gegen elektromagnetische Störungen (27) an das genannte Flüssigkristallanzeigepanel (17) mittels eines Index-angepassten optischen Bindungsmaterials (29) gebunden ist.
18. Flüssigkristallanzeige (11), gemäß Anspruch 17, weiterhin eine Antireflexionsbeschichtung (39) umfassend, die auf der Vorderseite des genannten dritten Glassubstrats (35) aufgebracht ist.
19. Flüssigkristallanzeige (11), gemäß Anspruch 18, weiterhin eine Hintergrundbeleuchtung (41) umfassend, die hinter dem genannten zweiten Glassubstrat (15) positioniert ist.
20. Flüssigkristallanzeige (11), gemäß Anspruch 19, worin die genannte Flüssigkristallanzeigepanel (17) ein Aktiv-Matrix-Flüssigkristallanzeigepanel ist.
21. Flüssigkristallanzeige (11), gemäß Anspruch 19, worin sowohl der genannte Frontpolarisator (31) als auch der genannte Rückpolarisator (19) nichtkompensierende Linearpolarisatoren sind.
22. Flüssigkristallanzeige (11), gemäß Anspruch 19, worin sowohl der genannte Frontpolarisator (31) als auch der genannte Rückpolarisator (19) eine Kompensationsschicht einschließen, wobei die genannte Kompensationsschicht in Richtung der genannten Flüssigkristallanzeige (17) zeigt.
2. Affichage à cristaux liquides (11) selon la revendication 1 comprenant en outre un bouclier d'interférences électromagnétiques (27) positionné entre ledit premier substrat de verre (13) et ledit panneau d'affichage à cristaux liquides (17).
3. Affichage à cristaux liquides (11) selon la revendication 2 dans lequel ledit bouclier d'interférences électromagnétiques (27) est un revêtement en film mince d'oxyde d'indium-étain appliqué sur le premier substrat de verre (13).
4. Affichage à cristaux liquides (11) selon la revendication 1 comprenant en outre un troisième substrat de verre (35), ledit troisième substrat de verre (35) étant positionné en avant dudit polariseur avant (31).
5. Affichage à cristaux liquides (11) selon la revendication 4 comprenant en outre un revêtement anti-réfléchissant (39), ledit revêtement anti-réfléchissant (39) étant appliqué sur l'avant dudit troisième substrat de verre (35).
6. Affichage à cristaux liquides (11) selon la revendication 1 dans lequel chacun dudit polariseur avant (31) et dudit polariseur arrière (19) est un polariseur linéaire non compensé.
7. Affichage à cristaux liquides (11) selon la revendication 1 dans lequel chacun dudit polariseur avant (31) et dudit polariseur arrière (19) inclut une couche de compensation.
8. Affichage à cristaux liquides (11) selon la revendication 7 dans lequel ladite couche de compensation de chacun dudit polariseur avant (31) et dudit polariseur arrière (19) fait face à l'opposé dudit panneau d'affichage à cristaux liquides (17).
9. Affichage à cristaux liquides (11) selon la revendication 1 dans lequel ledit panneau d'affichage à cristaux liquides (17) est un panneau d'affichage à cristaux liquides à matrice active.
10. Affichage à cristaux liquides (11) selon la revendication 1 comprenant en outre un rétro-éclairage (41), ledit rétro-éclairage (41) étant positionné derrière ledit deuxième substrat de verre (15).
11. Affichage à cristaux liquides (11) selon la revendication 1 comprenant en outre un élément chauffant (23) adapté pour être connecté à une source d'alimentation, ledit élément chauffant (23) étant positionné entre ledit polariseur arrière (19) et ledit deuxième substrat de verre (15).
12. Affichage à cristaux liquides (11) selon la revendication 11 dans lequel ledit élément chauffant (23)

Revendications

1. Affichage à cristaux liquides (11) comprenant :

un premier substrat de verre (13) ; un deuxième substrat de verre (15) ; un panneau d'affichage à cristaux liquides (17) positionné entre ledit premier substrat de verre (13) et ledit deuxième substrat de verre (15) ; un polariseur arrière (19) positionné entre ledit panneau d'affichage à cristaux liquides (17) et ledit deuxième substrat de verre (15) ; et un polariseur avant (31), ledit polariseur avant (31) étant croisé par rapport audit polariseur arrière (19) **caractérisé en ce que** ledit polariseur arrière (19) adhère directement audit panneau d'affichage à cristaux liquides (17) avec un adhésif (21) et **en ce que** ledit polariseur avant (31) est positionné en avant dudit premier substrat de verre (13).

- comprend un revêtement d'oxyde d'indium-étain appliqué audit deuxième substrat de verre (15).
- 13.** Affichage à cristaux liquides (11) selon la revendication 2 comprenant en outre :
- un troisième substrat de verre (35) positionné en avant dudit polariseur avant (31).
- 14.** Affichage à cristaux liquides (11) selon la revendication 13 dans lequel ledit premier substrat de verre (13), ledit deuxième substrat de verre (15), ledit troisième substrat de verre (35), ledit panneau d'affichage à cristaux liquides (17), ledit polariseur avant (31), ledit polariseur arrière (19) et ledit bouclier d'interférences électromagnétiques (27) ont tous des indices de réfraction qui correspondent substantiellement.
- 15.** Affichage à cristaux liquides (11) selon la revendication 14 comprenant en outre un élément chauffant (23) positionné entre ledit polariseur arrière (19) et ledit deuxième substrat de verre (15) et adapté pour être connecté à une source d'alimentation destinée à une utilisation comme un élément chauffant, ledit élément chauffant (23) ayant un indice de réfraction correspondant substantiellement à celui dudit polariseur arrière (19) et à celui dudit deuxième substrat de verre (15).
- 16.** Affichage à cristaux liquides (11) selon la revendication 15 dans lequel ledit élément chauffant (23) est un revêtement appliqué audit troisième substrat de verre (35) et dans lequel ledit bouclier électromagnétique (27) est un revêtement appliqué audit premier substrat de verre (13).
- 17.** Affichage à cristaux liquides (11) selon la revendication 16 dans lequel ledit polariseur avant (31) adhère audit troisième substrat de verre (35) avec un adhésif sensible à la pression (37) à correspondance d'indice et est lié audit premier substrat de verre (13) avec une matière de liaison optique (33) à correspondance d'indice, dans lequel ledit polariseur arrière (19) adhère audit panneau d'affichage à cristaux liquides (17) avec un adhésif sensible à la pression (21) à correspondance d'indice et est lié audit élément chauffant (23) avec une matière de liaison optique (25) à correspondance d'indice et dans lequel ledit bouclier d'interférences électromagnétiques (27) est lié audit panneau d'affichage à cristaux liquides (17) avec une matière de liaison optique (29) à correspondance d'indice.
- 18.** Affichage à cristaux liquides (11) selon la revendication 17 comprenant en outre un revêtement anti-réfléchissant (39) appliqué sur l'avant dudit troisième substrat de verre (35).
- 19.** Affichage à cristaux liquides (11) selon la revendication 18 comprenant en outre un rétro-éclairage (41) positionné derrière ledit deuxième substrat de verre (15).
- 20.** Affichage à cristaux liquides (11) selon la revendication 19 dans lequel ledit panneau d'affichage à cristaux liquides (17) est un panneau d'affichage à cristaux liquides à matrice active.
- 21.** Affichage à cristaux liquides (11) selon la revendication 19 dans lequel ledit polariseur avant (31) et ledit polariseur arrière (19) sont des polariseurs linéaires non compensés.
- 22.** Affichage à cristaux liquides (11) selon la revendication 19 dans lequel chacun dudit polariseur avant (31) et dudit polariseur arrière (19) inclut une couche de compensation, ladite couche de compensation faisant face à l'opposé dudit panneau d'affichage à cristaux liquides (17).

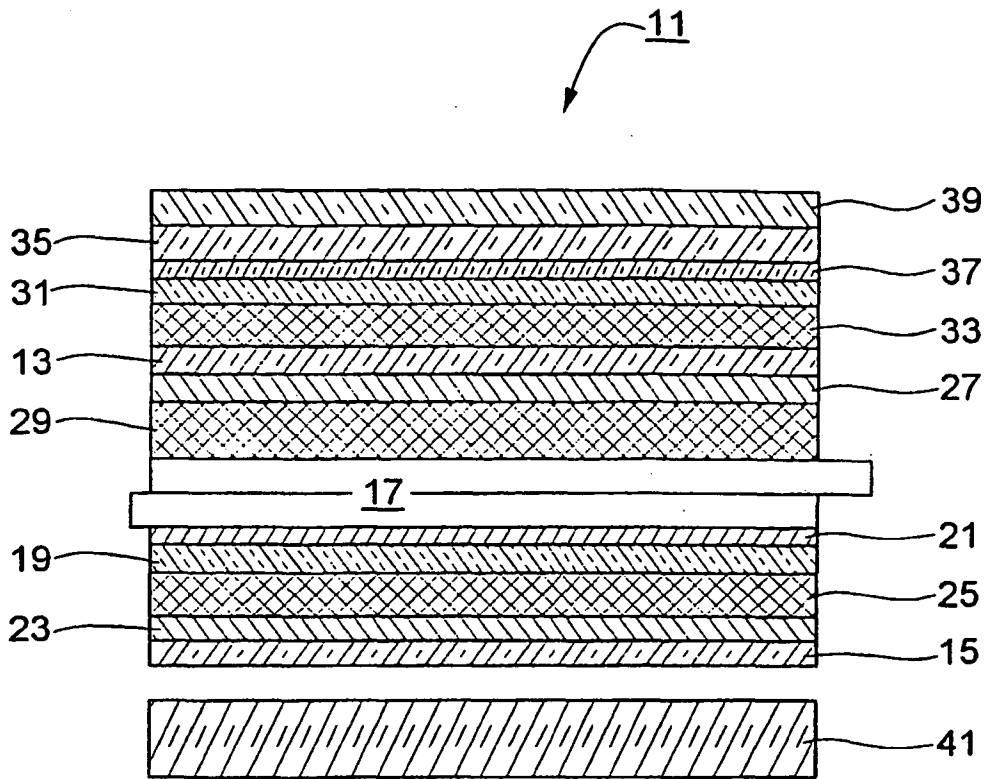

FIG. 1

REFERENCES CITED IN THE DESCRIPTION

This list of references cited by the applicant is for the reader's convenience only. It does not form part of the European patent document. Even though great care has been taken in compiling the references, errors or omissions cannot be excluded and the EPO disclaims all liability in this regard.

Patent documents cited in the description

- US 5570214 A, Abileah [0006]
- US 5594568 A, Abileah [0007]
- US 5706068 A, Abileah [0008]
- US 5739881 A, Xu [0009]
- US 5523873 A, Bradford [0010]
- US 5148299 A, Terada [0011]
- EP 0502364 A [0012]
- US 3869196 A, Kubota [0013]
- US 543060 A, Smith [0014]
- US 5179457 A, Hirataka [0015]

专利名称(译)	超高亮度低反射率液晶显示器		
公开(公告)号	EP1169666B1	公开(公告)日	2009-07-22
申请号	EP2000904192	申请日	2000-01-04
申请(专利权)人(译)	怀特电子设计CORP.		
当前申请(专利权)人(译)	怀特电子设计CORP.		
[标]发明人	SANELLE JOSEPH J BREILING DIGGY R		
发明人	SANELLE, JOSEPH, J. BREILING, DIGGY, R.		
IPC分类号	G02F1/1335 G02F1/13 G02F1/133 G02F1/1333		
CPC分类号	G02F1/133502 G02F1/1333 G02F1/133382 G02F1/133528 G02F2001/133334 G02F2001/13356 G02F2001/133562 G02F2001/133567		
代理机构(译)	舒伯特, 克莱门斯		
优先权	09/235584 1999-01-22 US		
其他公开文献	EP1169666A1 EP1169666A4		
外部链接	Espacenet		

摘要(译)

LCD (11) 包括后偏光器 (19) , 后偏光器 (19) 用折射率匹配的压敏粘合剂 (21) 粘附到AMLCD面板 (17) 的后部。适于用作加热元件的ITO涂层 (23) 被施加到第二玻璃基板 (15) 的前部。加热元件也用基于硅氧烷的折射率匹配的光学粘合材料 (25) 粘附到后偏振器上。可用作EMI屏蔽的另一ITO涂层 (27) 被施加到第一玻璃基板 (13) 的后部。EMI屏蔽也用上述粘接材料粘附在AMLCD面板的前面。通过上述接合材料将相对于后偏光器交叉的前偏光器 (31) 粘附到第一玻璃基板的前面。通过上述敏感粘合剂将第三玻璃基板 (35) 粘合到前偏振器的前面。将抗反射涂层 (39) 施加到第三玻璃基板的前面。背光 (41) 位于第二玻璃基板的后面。

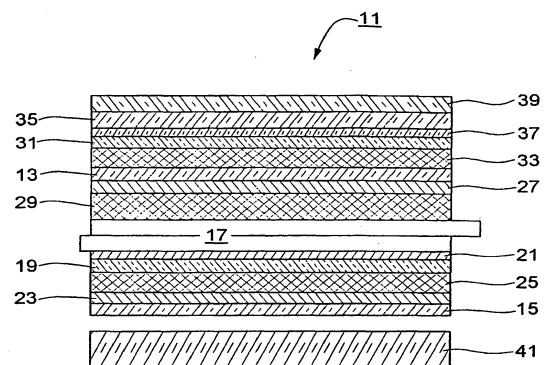

FIG. 1