



(12) **EUROPEAN PATENT APPLICATION**

(88) Date of publication A3:
10.09.2003 Bulletin 2003/37

(51) Int Cl.⁷: **G09G 3/36**

(43) Date of publication A2:
05.09.2001 Bulletin 2001/36

(21) Application number: **01104477.3**

(22) Date of filing: **28.02.2001**

(84) Designated Contracting States:
**AT BE CH CY DE DK ES FI FR GB GR IE IT LI LU
MC NL PT SE TR**
Designated Extension States:
AL LT LV MK RO SI

(30) Priority: **01.03.2000 JP 2000055874**
29.03.2000 JP 2000091612
31.03.2000 JP 2000099828
31.03.2000 JP 2000099829
31.03.2000 JP 2000099830
06.11.2000 JP 2000338097

(71) Applicant: **MINOLTA CO., LTD.**
Chuo-Ku, Osaka-Shi, Osaka 541-8556 (JP)

(72) Inventors:
• **Yoneda, Shuji, Minolta Co., Ltd.**
Chuo-ku, Osaka-shi, Osaka 541-8556 (JP)
• **Nakai, Masaaki, Minolta Co., Ltd.**
Chuo-ku, Osaka-shi, Osaka 541-8556 (JP)
• **Yamakawa, Eiji, Minolta Co., Ltd.**
Chuo-ku, Osaka-shi, Osaka 541-8556 (JP)

- **Hashimoto, Kiyofumi, Minolta Co., Ltd.**
Chuo-ku, Osaka-shi, Osaka 541-8556 (JP)
- **Masazumi, Naoki, Minolta Co., Ltd.**
Chuo-ku, Osaka-shi, Osaka 541-8556 (JP)
- **Asai, Katsuhiko, Minolta Co., Ltd.**
Chuo-ku, Osaka-shi, Osaka 541-8556 (JP)
- **Kohriyama, Koichi, Minolta Co., Ltd.**
Chuo-ku, Osaka-shi, Osaka 541-8556 (JP)
- **Ochi, Keizou, Minolta Co., Ltd.**
Chuo-ku, Osaka-shi, Osaka 541-8556 (JP)
- **Kondo, Takashi, Minolta Co., Ltd.**
Chuo-ku, Osaka-shi, Osaka 541-8556 (JP)
- **Hotomi, Hideo, Minolta Co., Ltd.**
Chuo-ku, Osaka-shi, Osaka 541-8556 (JP)
- **Okumura, Kazuaki, Minolta Co., Ltd.**
Chuo-ku, Osaka-shi, Osaka 541-8556 (JP)
- **Mandai, Makiko, Minolta Co., Ltd.**
Chuo-ku, Osaka-shi, Osaka 541-8556 (JP)

(74) Representative: **HOFFMANN - EITLÉ**
Patent- und Rechtsanwälte
Arabellastrasse 4
81925 München (DE)

(54) **Liquid crystal display device**

(57) A display device which has a liquid crystal display which has a plurality liquid crystal pixels arranged in a matrix and which writes an image thereon after resetting the liquid crystal. The method of writing on the liquid crystal display can be selected from driving methods according to interlace scanning in which a frame is divided into a plurality of fields and writing by interlace scanning is performed and driving methods according to sequential scanning in which scanning lines are subjected to writing serially. When high-speed writing is required, for example, when display of a motion picture, display of inputted letters or scroll display is desired, one of the driving methods according to interlace scanning is selected. In interlace scanning, based on the end of a blackout state of a scanning line in a field, selection of a scanning line in the next field for writing is started.

Writing on a scanning line comprises a reset step of resetting the liquid crystal, a selection step of selecting the final state of the liquid crystal, an evolution step of stabilizing the liquid crystal into the selected state, and one of the length of the reset step and the total length of the selection step and the evolution step is n times (n: natural number) the other. For example, when the length of the reset step is n times the total length of the selection step and the evolution step and when a frame is divided into m fields (m: natural number larger than n) for interlace scanning, there is a moment when, in serial m scanning lines, n scanning lines of them are in the reset step, one of them is in the selection step or in the evolution step, and the other m-n-1 scanning lines are in a display step.

FIG. 3

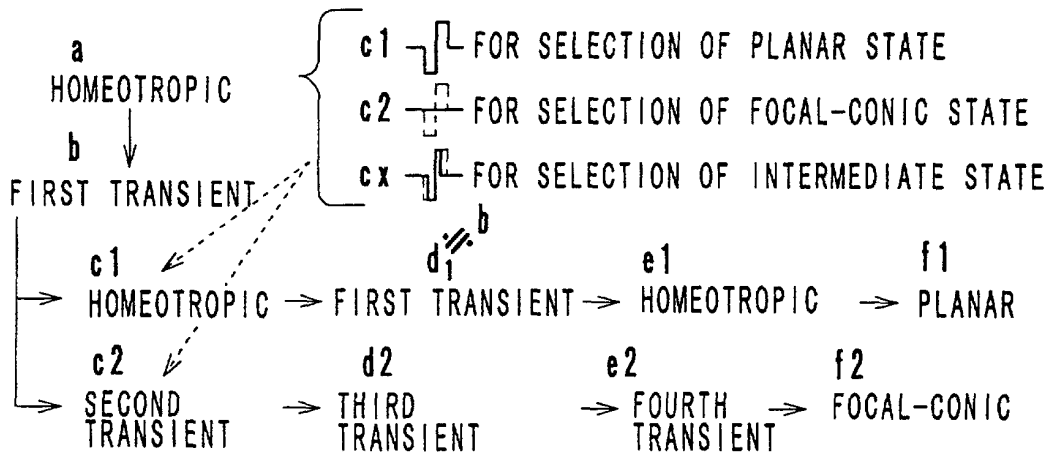
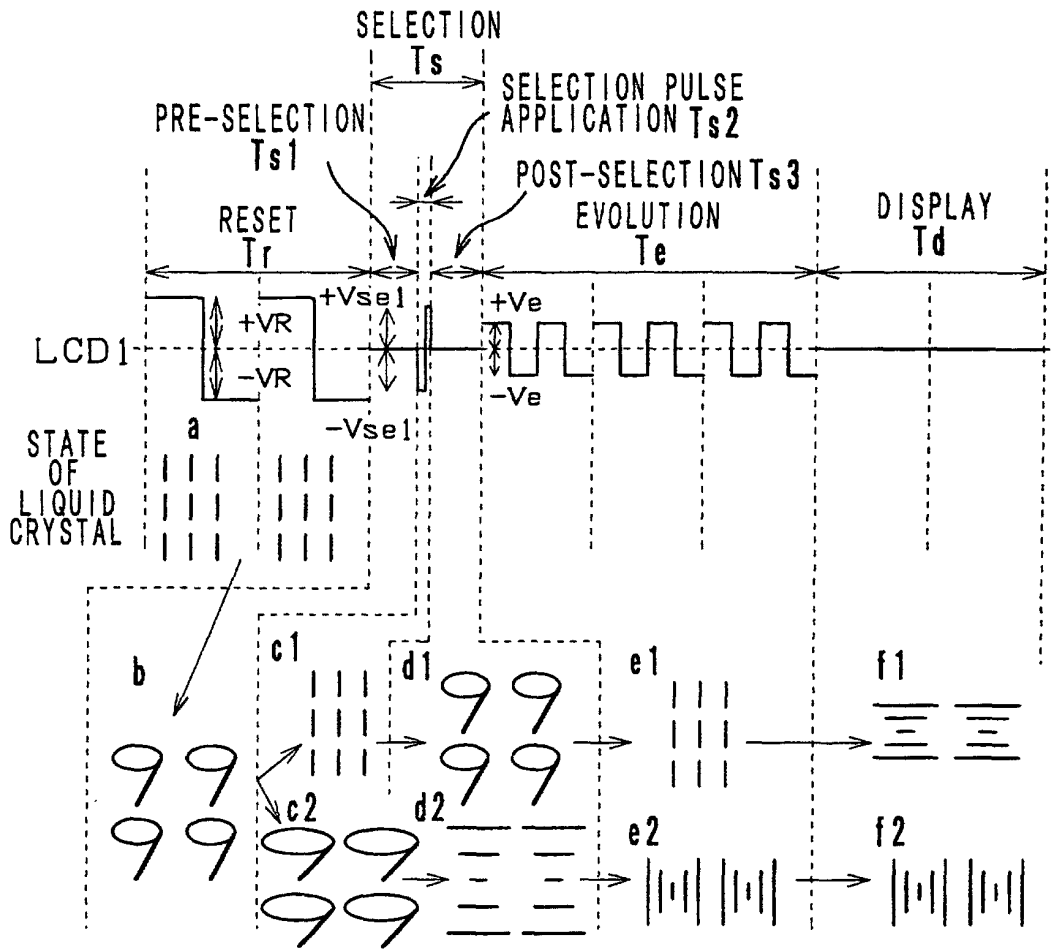



European Patent Office

EUROPEAN SEARCH REPORT

Application Number
EP 01 10 4477

DOCUMENTS CONSIDERED TO BE RELEVANT			
Category	Citation of document with indication, where appropriate, of relevant passages	Relevant to claim	CLASSIFICATION OF THE APPLICATION (Int.Cl.7)
X	EP 0 772 067 A (SEIKO EPSON CORP) 7 May 1997 (1997-05-07)	1,19,20	G09G3/36
Y	* the whole document *	3,13-18	
A	---	4-12	
X	US 5 943 035 A (KATAKURA KAZUNORI) 24 August 1999 (1999-08-24)	1,19	
Y	* the whole document *	3,5-8, 13-18	
A	---	4,9-12, 20	
Y	EP 0 569 029 A (SEIKO EPSON CORP) 10 November 1993 (1993-11-10) * the whole document *	3,5-8, 13-18	TECHNICAL FIELDS SEARCHED (Int.Cl.7) G09G
Y	HUANG X Y ET AL: "High-Performance Dynamic Drive Scheme for Bistable Reflective Cholesteric Displays" SID INTERNATIONAL SYMPOSIUM. DIGEST OF TECHNICAL PAPERS. SAN DIEGO, MAY 12 - 17, 1996, SANTA ANA, SID, US, vol. 27, May 1996 (1996-05), pages 359-362, XP002112794 ISSN: 0097-966X * the whole document *	3,5-8, 13-18	
The present search report has been drawn up for all claims			
Place of search MUNICH		Date of completion of the search 11 July 2003	Examiner Harke, M
CATEGORY OF CITED DOCUMENTS X : particularly relevant if taken alone Y : particularly relevant if combined with another document of the same category A : technological background O : non-written disclosure P : intermediate document		T : theory or principle underlying the invention E : earlier patent document, but published on, or after the filing date D : document cited in the application L : document cited for other reasons & : member of the same patent family, corresponding document	

EPO FORM 1503 03.82 (P04C01)

**ANNEX TO THE EUROPEAN SEARCH REPORT
ON EUROPEAN PATENT APPLICATION NO.**

EP 01 10 4477

This annex lists the patent family members relating to the patent documents cited in the above-mentioned European search report. The members are as contained in the European Patent Office EDP file on
The European Patent Office is in no way liable for these particulars which are merely given for the purpose of information.

11-07-2003

Patent document cited in search report		Publication date	Patent family member(s)	Publication date
EP 0772067	A	07-05-1997	DE 69526505 D1	29-05-2002
			DE 69526505 T2	31-10-2002
			EP 0772067 A1	07-05-1997
			HK 1021612 A1	27-09-2002
			KR 254647 B1	01-05-2000
			US 6252571 B1	26-06-2001
			CN 1152962 A	25-06-1997
			WO 9636902 A1	21-11-1996

US 5943035	A	24-08-1999	JP 8005991 A	12-01-1996

EP 0569029	A	10-11-1993	DE 69318062 D1	28-05-1998
			DE 69318062 T2	01-10-1998
			EP 0569029 A2	10-11-1993
			JP 6230751 A	19-08-1994
			JP 2000356765 A	26-12-2000
			KR 264189 B1	16-08-2000
			SG 63551 A1	30-03-1999
			US 5594464 A	14-01-1997
US 5900852 A	04-05-1999			

专利名称(译)	液晶显示装置		
公开(公告)号	EP1130568A3	公开(公告)日	2003-09-10
申请号	EP2001104477	申请日	2001-02-28
[标]申请(专利权)人(译)	美能达株式会社		
申请(专利权)人(译)	MINOLTA CO. , LTD.		
当前申请(专利权)人(译)	MINOLTA CO. , LTD.		
[标]发明人	YONEDA SHUJI MINOLTA CO LTD NAKAI MASA AKI MINOLTA CO LTD HASHIMOTO KIYOFUMI MINOLTA CO LTD ASAI KATSUHIKO MINOLTA CO LTD KOHRIYAMA KOICHI MINOLTA CO LTD OCHI KEIZOU MINOLTA CO LTD KONDO TAKASHI MINOLTA CO LTD HOTOMI HIDEO MINOLTA CO LTD OKUMURA KAZUAKI MINOLTA CO LTD MANDAI MAKIKO MINOLTA CO LTD		
发明人	YONEDA, SHUJI, MINOLTA CO., LTD. NAKAI, MASA AKI, MINOLTA CO., LTD. YAMAKAWA, EIJI, MINOLTA CO., LTD. HASHIMOTO, KIYOFUMI, MINOLTA CO., LTD. MASAZUMI, NAOKI, MINOLTA CO., LTD. ASAI, KATSUHIKO, MINOLTA CO., LTD. KOHRIYAMA, KOICHI, MINOLTA CO., LTD. OCHI, KEIZOU, MINOLTA CO., LTD. KONDO, TAKASHI, MINOLTA CO., LTD. HOTOMI, HIDEO, MINOLTA CO., LTD. OKUMURA, KAZUAKI, MINOLTA CO., LTD. MANDAI, MAKIKO, MINOLTA CO., LTD.		
IPC分类号	G09G3/36		
CPC分类号	G09G3/3629 G09G2300/023 G09G2300/0486 G09G2310/0227 G09G2310/061		
优先权	2000099830 2000-03-31 JP 2000055874 2000-03-01 JP 2000338097 2000-11-06 JP 2000099829 2000-03-31 JP 2000099828 2000-03-31 JP 2000091612 2000-03-29 JP		
其他公开文献	EP1130568A2		
外部链接	Espacenet		

摘要(译)

一种显示装置，其具有液晶显示器，该液晶显示器具有以矩阵排列的多个液晶像素，并且在重置液晶之后在其上写入图像。在液晶显示器上写入的方法可以从根据隔行扫描的驱动方法中选择，其中帧被分成多个场并且通过隔行扫描进行写入，以及根据顺序扫描的驱动方法，其中扫描线经受扫描线连续写作。当需要高速写入时，例如，当需要显示运动图像，输入字母的显示或滚动显示时，选择根据隔行扫描的一种驱动方法。在隔行扫描中，基于场中扫描线的中断状态的结束，开始在下一个用于写入的场中选择扫描

线。在扫描线上写入包括重置液晶的重置步骤，选择步骤选择液晶的最终状态，使液晶进入选定状态的演变步骤，以及复位步骤的长度和选择步骤和进化步骤的总长度之一是 n 次（ n ：自然的数字）另一个。例如，当复位步长的长度是选择步骤和演变步骤的总长度的 n 倍，并且当帧被分成 m 个场（ m ：大于 n 的自然数）以进行隔行扫描时，有一个时刻当在串行 m 条扫描线中，它们的 n 条扫描线处于复位步骤时，其中一条处于选择步骤或进化步骤，而其他 $mn-1$ 条扫描线处于显示步骤。

FIG. 3

